

Vacuum Pumps

Instrumentation

Fittings and Valves



LEYBOLD VACUUM

GA 03.107/10.02



**RUVAC WA/WAU
151/251/501/1001/2001**

Roots pumps

- Cat. No.
- 117 10/20/30/40/50
- 117 11/21/31/41/51
- 118 31/41/51

- 117 24/34/44

- 917 10/20/30/40/50
- 917 11/21/31/41/51

Operating Instructions

Contents

| | Page |
|--|-------------|
| 1 Description | 3 |
| 1.1 Design and function | 3 |
| 1.2 Standard specification | 6 |
| 1.3 Technical data | 7 |
| 1.4 Accessories | 9 |
| 2 Transportation and storage | 10 |
| 3 Installation and connection | 11 |
| 3.1 Installation | 11 |
| 3.2 Filling in of the lubricants | 11 |
| 3.3 Electrical connections | 12 |
| 3.4 Connection of the flanges | 14 |
| 4 Operation | 15 |
| 4.1 Start-up | 15 |
| 4.2 Operation | 15 |
| 4.3 Shutdown and storage | 16 |
| 4.4 Changing from vertical to horizontal flow ... | 16 |
| 5 Maintenance | 18 |
| 5.1 Safety information | 18 |
| 5.2 Oil change / gear box | 19 |
| 5.3 Oil change/shaft seal housing | 19 |
| 5.4 Cleaning the fan cowl and the cooling fins .. | 20 |
| 5.5 Cleaning the dirt trap | 20 |
| 5.6 Cleaning the pumping chamber | 20 |
| 5.7 Cleaning the valve of the pressure balance line | 21 |
| 5.8 Exchanging the shaft seals | 22 |
| 5.9 Leybold service | 24 |
| 6 Troubleshooting | 26 |
| EEC Manufacturer's Declaration | 29 |
| Declaration of Conformity | 31 |

Warning Indicates procedures that must be strictly observed to prevent hazards to persons.



Caution Indicates procedures that must strictly be observed to prevent damage to, or destruction of the equipment.

Figures

The references to figures, e.g. (1/2) consist of the Fig. No. and the Item No. in that order.

Leybold Service

If a pump is returned to Leybold, indicate whether the pump free of substances damaging to health or whether it is contaminated.

If it is contaminated also indicate the nature of the hazard. Leybold must return any pumps without a "Declaration of Contamination" to the sender's address.

Disposal of waste oil

Under the amended law relating to waste disposal dated November 1, 1986 (valid in the Federal Republic of Germany) the disposal of used oil is subject to new provisions. According to legislation relating to waste disposal the so-called principle of causality is applied. Hence, anyone in possession of used oil is responsible for its proper disposal.

Used oils coming from vacuum pumps must not be mixed with other substances.

Used oils from vacuum pumps (Leybold-oils on the basis of mineral oils) having been affected by normal contamination due to oxygen from the ambient air, increases in temperature and mechanical wear, must be disposed of as used oil in accordance with the regulations.

Used oils from vacuum pumps that have been contaminated by other substances must be labelled, stored and disposed of as special waste with reference to the kind of contamination.

When disposing of used oil please observe the safety regulations that are valid in your country.

In many countries proof of where the oil has finally been left is required by Law and often shipping of such contaminated waste requires permission by the authorities.

Waste disposal information is available through:

Bundesamt für Gewerbliche Wirtschaft (BAW)

Frankfurter Str. 29-31

D-65760 Eschborn/Taunus

Phone: +49 (0)6196 4041 – Telex: 415603/04

We reserve the right to modify the design and the specified data. The illustrations are not binding.

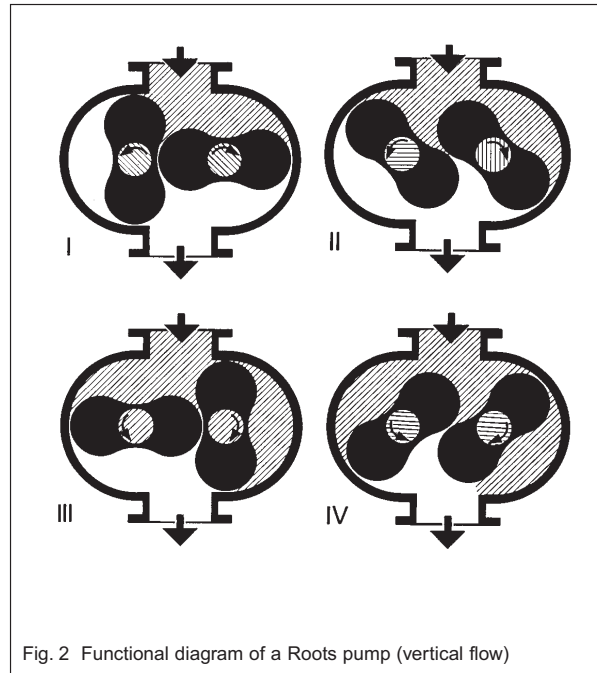
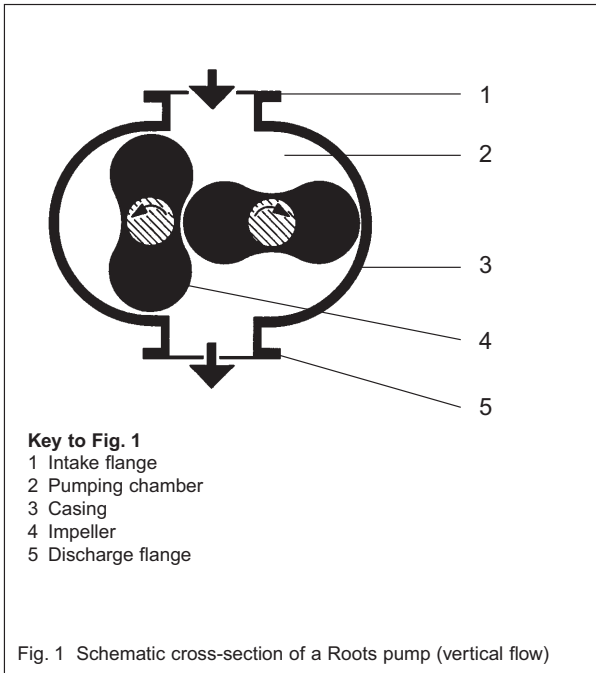

1 Description

1.1 Design and Function

The RUVAC WA and RUVAC WAU are Roots vacuum pumps which are driven directly by an electric motor.

The WAU types have a pressure balance line between the discharge and intake flange.

Standard RUVAC pumps are not suited for pumping of oxygen when the oxygen concentration exceeds that in the atmosphere.

Before planning to use RUVAC pumps for pumping of highly aggressive gases, contact us first.

1.1.1 Principle of Operation

Roots pumps – also known as Roots blowers – contain in their pump casing (1/3) two symmetrical impellers (1/4) rotating in opposite directions. The impellers have roughly the cross section of a figure “8” and are synchronized by a toothed gearing so that they move past each other and the casing without contact but with a small clearance.

The principle of operation is explained in Fig. 2.

In impeller positions I and II, the volume in the intake flange is increased. When the impellers rotate further to position III, part of the volume is sealed off from the intake side.

In position IV, this volume is opened to the discharge side, and gas at backing pressure (higher than the intake pressure) flows in. The inflowing gas compresses the gas volume pumped from the intake side. As the impellers rotate further, the compressed gas is ejected via the discharge flange.

This process occurs twice per complete revolution of each of the two impellers.

Due to the non-contacting rotation in the pumping chamber, Roots pumps can be operated at high speeds (standard $n = 3,000$ rpm at a mains frequency of 50 Hz). Thus a relatively high pumping speed is attained with small pumps.

The pressure differential and compression ratio between the intake and discharge sides are limited on Roots pumps. If the allowable pressure differential is exceeded, the pump overheats.

In practice, the maximum attainable pressure differential is significant only in the rough vacuum range ($p > 10$ mbar), whereas for pressures in the fine vacuum range ($p < 1$ mbar) the attainable compression ratio is decisive.

RUVAC pumps from the WA/WAU range have been specifically designed for operation in the rough and fine vacuum ranges. They are thus either used in connection with backing pumps or in closed gas cycles. The pump's power consumption depends not only on the pumping

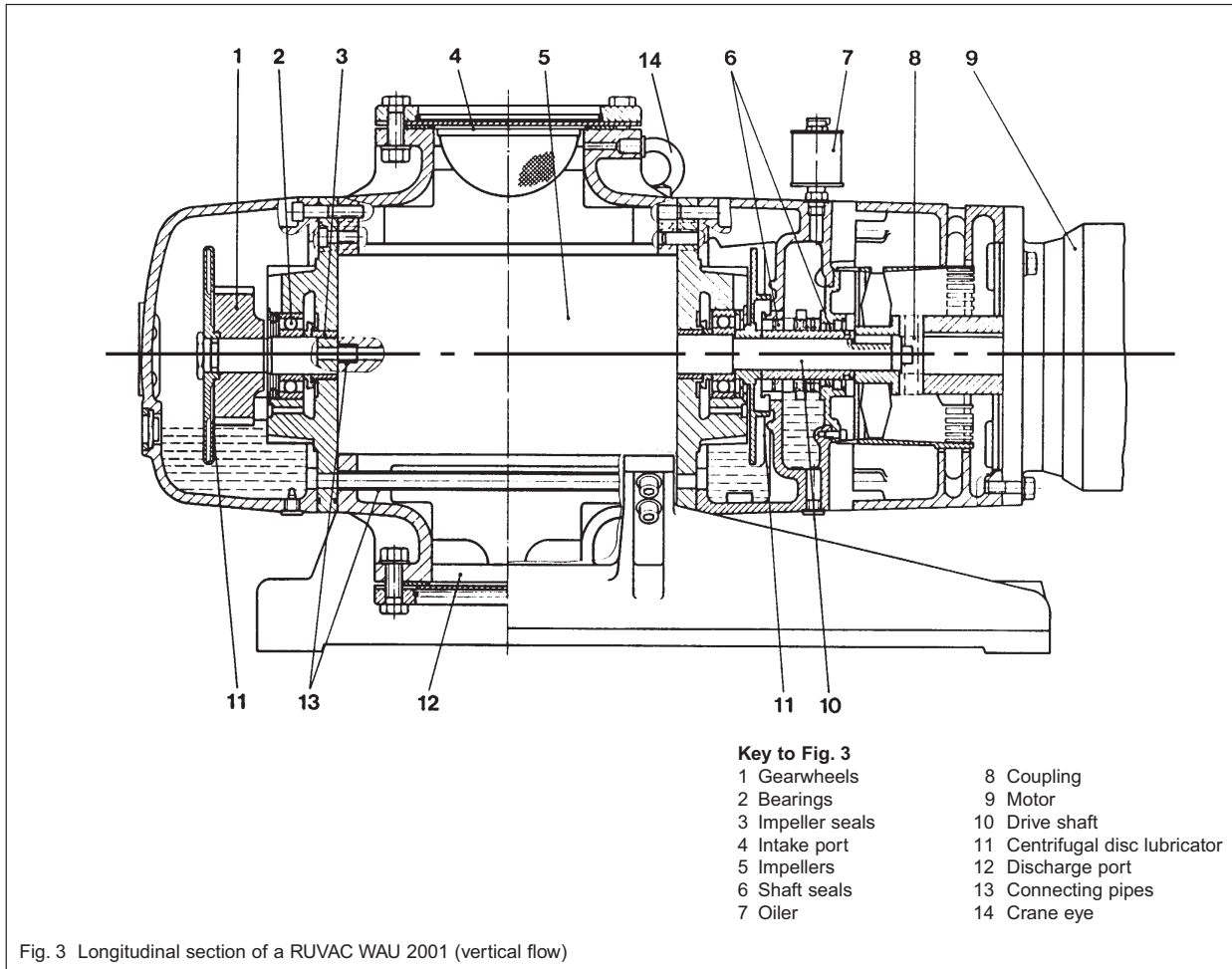

Fig. 3 Longitudinal section of a RUVAC WAU 2001 (vertical flow)

chamber volume and the rotational speed of the pump, but also on the pressure differential between the discharge and intake flanges (see Fig. 7).

1.1.2 Design

RUVAC Roots pumps can pump gas in the vertical or horizontal direction.

Although the pumping chamber of Roots pumps is free of sealing agents and lubricants, the two gearwheels of the synchromesh gearing (3/1) and the bearings (3/2) for the impeller shafts are lubricated with oil. The gearwheels and bearings of the RUVAC are located in two side chambers which also contain the oil supply.

These two side chambers are separated from the pumping chamber by the impeller seals (3/3). During operation of the pump, the side chambers are evacuated via the impeller seals.

The bearing chambers are linked to each other by two passages (3/13). These passages are arranged so that for either horizontal or vertical flow the pressure will be equalised between the oil supplies.

In both bearing chambers there are integrated oil pumps to ensure that the bearings and gearwheels receive sufficient lubricant at all recommended speeds.

The motor of the RUVAC WA/WAU is directly flanged to the coupling housing. One shaft of the pump is linked to the shaft of the motor by an elastic coupling (3/8). The shaft of the other impeller is driven via the synchromesh gear.

With the standard motors, the RUVAC WA/WAUs can run on either 50 Hz or 60 Hz power supplies.

The speed is then increased to 3,600 rpm and the pumping speed increases correspondingly.

For the permissible electrical connection data with respect to these frequencies, see Section 1.3.

Motors for operation in connection with special supply voltages or frequencies as well as explosion hazard protected motors are available upon request.

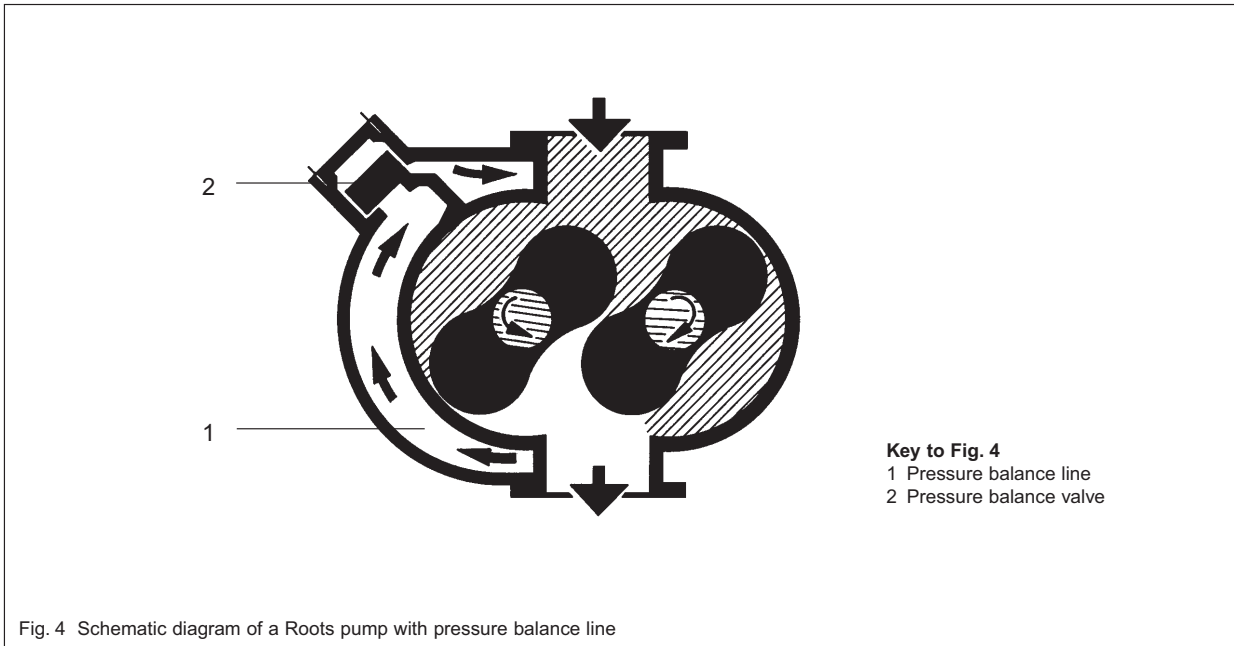

Fig. 4 Schematic diagram of a Roots pump with pressure balance line

The feedthrough of the impeller's shaft between the evacuated bearing space and the atmosphere is sealed by means of shaft seals. The shaft seals are immersed in oil. They are located in a seal housing with a separate oil reservoir. The oil level in the shaft seal housing can be checked at oiler (3/7).

RUVAC WA/WAUs are air-cooled. The airflow for cooling the motor and pump is produced by a fan which sits on the motor.

An additional blade wheel is located on the coupling for additional cooling.

1.1.3 Pressure Balance Line

The RUVAC WAU has an integrated pressure balance line (4/1). It links the discharge and intake flanges via a pressure balance valve.

If the pressure differential between the flanges is too large, the valve (4/2) opens. Some of the gas which has already been pumped then flows back through the line to the intake flange.

The valve is weight- and spring-loaded so that it works with both vertical and horizontal flow of the pump.

As a result of this pressure balance line, no additional devices are needed to protect the pump against excessive pressure differentials. The RUVAC WAU can be switched on at atmospheric pressure at the same time as a backing pump. As a result, the pumping speed of the pump combination is increased even at high intake pressures.

1.1.4 Lubricants

The standard RUVAC WA/WAU pumps are ready for operation with mineral oil.

We recommend the use of our N 62 oil for vacuum pumps (HE-200 in the USA). Other types of oil are available upon request.

Caution WA/WAU pumps running with a filling of PFPE today no longer meet the world-wide requirements for semiconductor processes. For such applications the WS/WSU models should be preferred.

1.1.5 Flange Connections

The cast flanges on the pump's body comply with DIN 2501, nominal pressure 6.

The pumps are supplied with different collar flanges:

Pumps with **Cat. Nos. beginning with 917...** are equipped with collar flanges corresponding to the **ASA standard**. These are intended for the American market ("US version").

Pumps with **Cat. Nos. beginning with 117...** are equipped with **ISO-K** collar flanges. This standard can be applied in all other parts of the world ("Euro version").

1.2 Standard Specification

RUVAC WA/WAUs are supplied for vertical flow as standard unless you specifically request horizontal flow. The shaft seal housing is supplied with a filling of oil.

Before the pump is shipped the oil has been drained out. The quantity of mineral oil needed for running the pump is supplied in a separate container.

Pumps with Cat. Nos. beginning with 117... are supplied with a sealing disc, a blank flange and an ISO-K collar flange fitted with the required number of screws. These pumps are equipped with a standard motor in accordance with the IEC standard.

The WA models are supplied without a motor, but have been prepared for operation in connection with a motor which complies with the IEC standard. The motor flange is sealed with a cardboard disc. The coupling is included with the pump.

Pumps with Cat. Nos. beginning with 917... are supplied with ASA adapter flanges. The ASA flanges are sealed with a piece of foil. Standard motors in accordance with the NEMA standard are attached to these pumps (flange motor T.E.F.C.).

The intake flanges of all pumps contain a wire mesh dirt trap and have been vented with nitrogen for protection against corrosion.

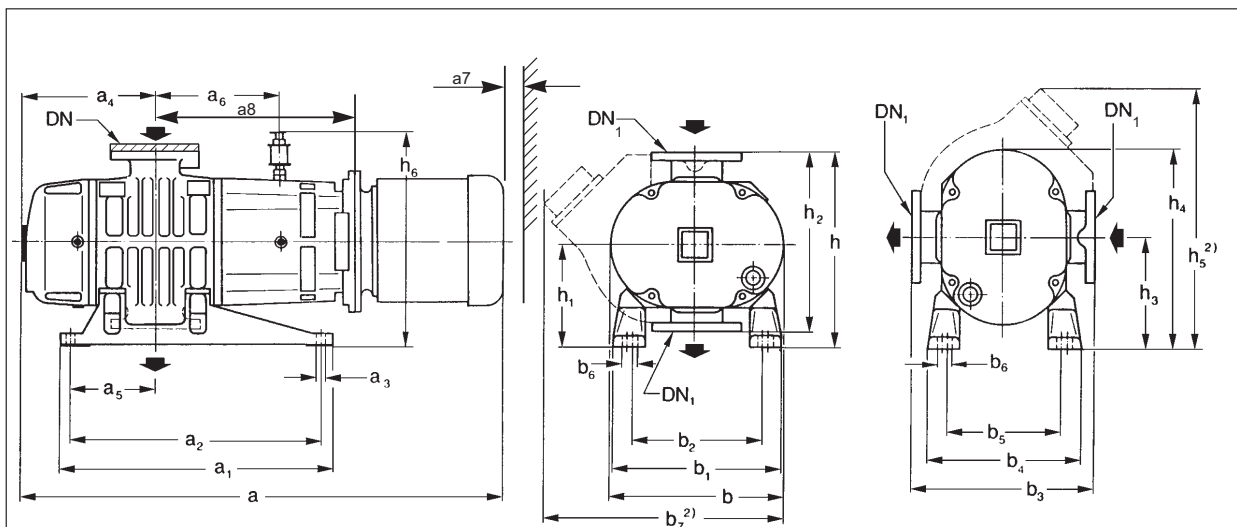

Table giving the dimensions for RUVAC WA and WAU ("Euro" versions/motor to IEC standard)

| Type | DN | DN ¹²⁾ | a | a1 | a2 | a3 | a4 | a5 | a6 | a7 | a8 |
|-------------|-----------|-------------------|------|-----|-----|------|-----|-----|-----|----|-----|
| WA 151 | 63 ISO-K | 65 | 669 | 400 | 364 | 14 | 180 | 97 | 163 | 50 | 258 |
| WAU 151 | 63 ISO-K | 65 | 669 | 400 | 364 | 14 | 180 | 97 | 163 | 50 | 258 |
| WA/WAU 251 | 63 ISO-K | 65 | 732 | 405 | 365 | 14 | 214 | 120 | 194 | 50 | 290 |
| WA/WAU 501 | 63 ISO-K | 65 | 835 | 486 | 450 | 14 | 242 | 155 | 218 | 50 | 323 |
| WA/WAU 1001 | 100 ISO-K | 100 | 1050 | 560 | 520 | 16,5 | 303 | 180 | 262 | 50 | 430 |
| WA/WAU2001 | 160 ISO-K | 150 | 1275 | 800 | 740 | 18 | 372 | 220 | 310 | 50 | 502 |

| Type | b | b1 | b2 | b3 | b4 | b5 | b6 | b7 ¹⁾ | h | h1 | h2 | h3 | h4 | h5 ¹⁾ | h6 |
|-------------|-----|-----|-----|-----|-----|-----|----|------------------|-----|-----|-----|-----|-----|------------------|-----|
| WA 151 | 250 | 280 | 215 | 280 | 240 | 175 | 24 | 305 | 300 | 160 | 280 | 180 | 306 | 360 | 330 |
| WAU 151 | 250 | 288 | 224 | 280 | 248 | 184 | 24 | 305 | 300 | 160 | 280 | 180 | 306 | 360 | 330 |
| WA/WAU 251 | 250 | 270 | 210 | 280 | 230 | 170 | 24 | 305 | 300 | 160 | 280 | 180 | 306 | 360 | 330 |
| WA/WAU 501 | 307 | 299 | 229 | 320 | 271 | 201 | 24 | 390 | 340 | 180 | 320 | 194 | 348 | 430 | 370 |
| WA/WAU 1001 | 372 | 352 | 278 | 370 | 320 | 246 | 24 | 490 | 396 | 211 | 370 | 227 | 414 | 532 | 425 |
| WA/WAU2001 | 457 | 518 | 388 | 460 | 422 | 292 | 24 | 635 | 530 | 300 | 460 | 351 | 578 | 753 | 541 |

¹⁾ On RUVAC WAU only

²⁾ To DIN 2501, nominal pressure 6

Fig. 5 Dimensional drawing for the RUVAC WA/WAU

1.3 Technical Data

50 Hz operation, SI units, "Euro versions"

| RUVAC WA / WAU | | 151 | 251 | 501 | 1001 | 2001 |
|---|----------------------------------|----------------------|------------|------------|-------------|-------------|
| Nominal pumping speed ¹⁾ | m ³ x h ⁻¹ | 153 | 253 | 505 | 1000 | 2050 |
| Maximum pumping speed at a pumping speed for the backing pump of | m ³ x h ⁻¹ | 130 | 210 | 450 | 890 | 1850 |
| | m ³ x h ⁻¹ | 40 | 65 | 160 | 250 | 630 |
| Possible cut-in pressure – RUVAC WA at a pumping speed for the backing pump of | mbar | 46 | 31 | 37 | 27 | 22 |
| | m ³ x h ⁻¹ | 40 | 65 | 160 | 250 | 630 |
| Maximum allowable pressure differential in continuous operation ²⁾ | mbar | 130 | 80 | 80 | 80 | 50 |
| Leak rate, integral | mbar · l · s ⁻¹ | 5 x 10 ⁻⁴ | | | | |
| Permissible ambient temperatures | °C | 12 – 40 | | | | |
| Mains voltage at the motor, 50 Hz | V | 230 / 400 | | | | 400 |
| Motor power, 50 Hz | kW | 0.75 | 1.1 | 2.2 | 4.0 | 7.5 |
| Nominal speed, 50 HZ | rpm | 3000 | 3000 | 3000 | 3000 | 3000 |
| Max. permissible speed | rpm | 3600 | 3600 | 3600 | 3600 | 3600 |
| Protection | IP | 54 | 54 | 54 | 54 | 54 |
| Oil filling for gear box – vertical flow – horizontal flow | l | 0.7 | 0.7 | 1.0 | 2.0 | 4.0 |
| | l | 0.5 | 0.5 | 0.7 | 1.2 | 2.0 |
| Oil filling for the shaft seal housing (vertical flow or horizontal flow) | l | 0.7 | 0.7 | 1.2 | 1.8 | 1.8 |
| Weight WA / WAU with motor | kg | 80 / 84 | 85 / 89 | 128 / 133 | 220 / 225 | 400 / 406 |
| Connection flanges | DN | 63 ISO - K | 63 ISO - K | 63 ISO - K | 100 ISO - K | 160 ISO - K |
| Noise level ³⁾ | dB (A) | < 63 | < 64 | < 67 | < 75 | < 80 |

Cat. Nos.

| | | | | | | |
|------------------------|--|--------|--------|--------|--------|--------|
| RUVAC WA | | 117 10 | 117 20 | 117 30 | 117 40 | 117 50 |
| RUVAC WA without motor | | – | 117 24 | 117 34 | 117 44 | – |
| RUVAC WAU | | 117 11 | 117 21 | 117 31 | 117 41 | 117 51 |

¹⁾ as per DIN 28 400 ff.

²⁾ The max. permissible pressure differential applies to ratios of up to 1:10 between roots pumps and backing pumps.

³⁾ at an operating pressure < 10⁻¹ mbar

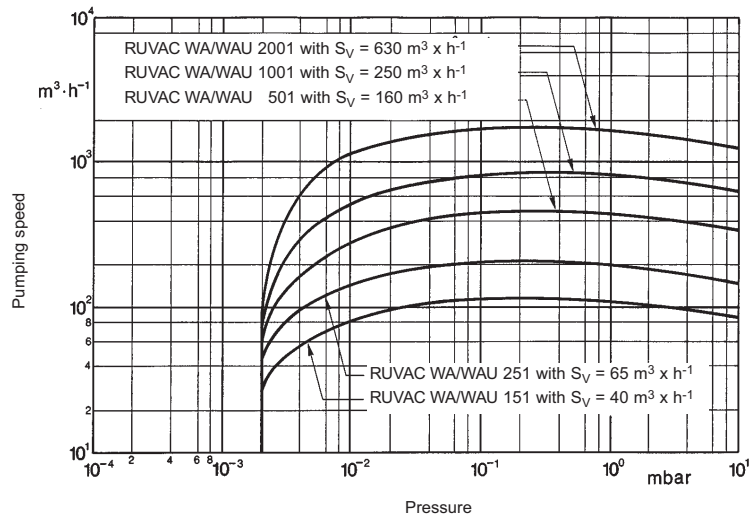

Fig. 6 Pumping speed characteristics for operation at 50 Hz

S_v = pumping speed of the backing pump

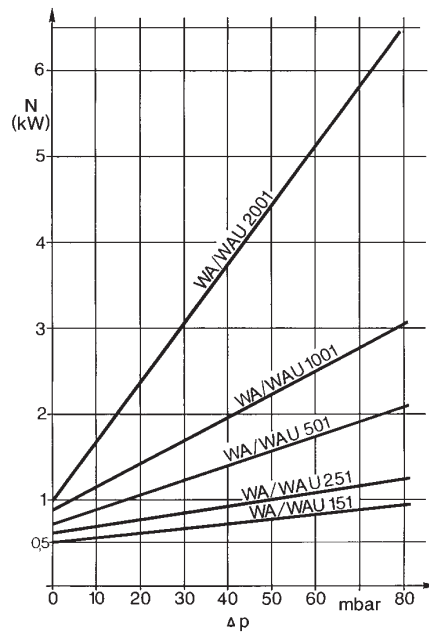

Fig. 7 Power consumption of the RUVAC WA/WAU

For US-Versions

Conversion of Units

Conversion factors

1 lb = 0.453 kg
 1 qt = 0.946 l
 1 hp = 0.735 kW
 1 rpm = 1 min⁻¹
 1 inch = 25.4 mm

Different pressure units

| mbar (millibar) | torr | Inches Hg vacuum |
|--------------------|------|---------------------|
| 1013 | 760 | 0 |
| 400 | 300 | 18.12 |
| 133 | 100 | 25.98 |
| 4 | 3 | 29.80 |
| 1 | 0.75 | 29.89 |
| 0 | 0 | 29.92 |

Different pumping speed units

| m ³ · h ⁻¹ m ³ · h ⁻¹ = m ³ /h | l · s ⁻¹ l · s ⁻¹ = l/s | cfm (cubic feet per minute) |
|--|--|--------------------------------|
| 1 | 0.278 | 0.589 |
| 3.60 | 1 | 12.12 |
| 1.699 | 0.472 | 1 |

1 atm (atmosphere) = 1013 bar
 1 Pa (pascal) = 0.01 bar = 10⁻² mbar
 1 bar = 1000 mbar

Example: 1 m³ h⁻¹ = 0.589 cfm
 Note: The nominal pumping speed of a pump at 60 Hz is 20 % higher than at 50 Hz.

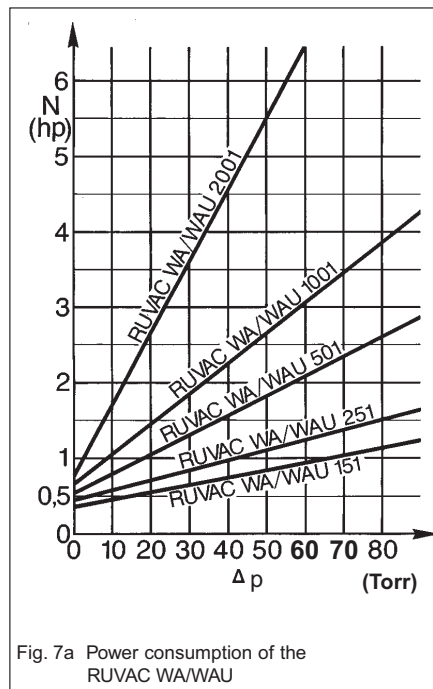
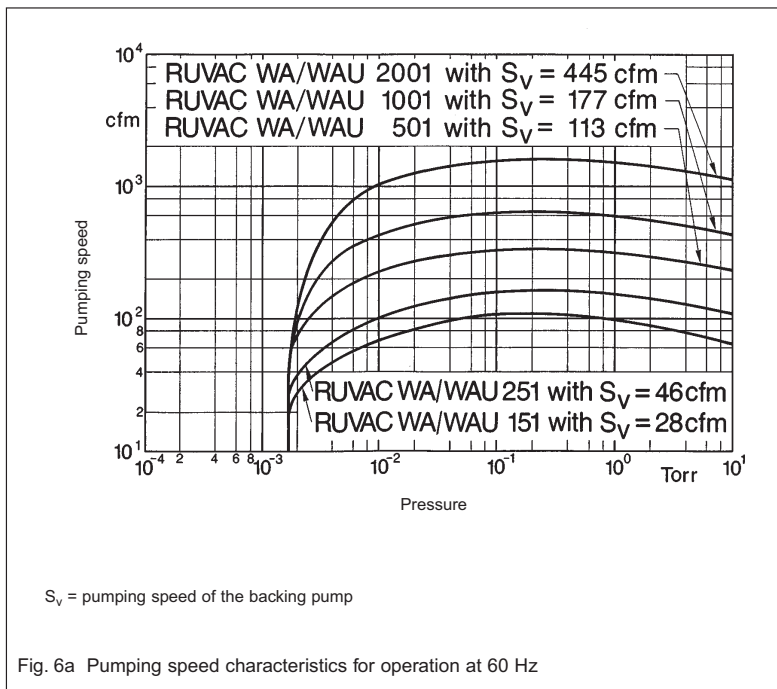

Technical Data

60 Hz-operation, English units, „US-Versions“; further technical Data see „Euro-Versions, page 7.

| RUVAC WA / WAU | | 151 | 251 | 501 | 1001 | 2001 |
|--|--------|-------------|-------------|-------------|-------------|-------------|
| Nominal pumping speed | cfm | 108 | 179 | 357 | 707 | 1449 |
| Maximum pumping speed at backing pump speed | cfm | 92 | 148 | 318 | 629 | 1308 |
| | cfm | 28 | 46 | 113 | 177 | 445 |
| Possible cut-in ressure RUVAC WA at backing pump speed | Torr | 35 | 23 | 28 | 20 | 16 |
| | cfm | 28 | 46 | 113 | 177 | 445 |
| Maximum allowable pressure differential in continuous operation | Torr | 98 | 60 | 60 | 60 | 38 |
| Supply voltage, 60 Hz, 3 phase | V / DC | 200/230/460 | 200/230/460 | 200/230/460 | 200/230/460 | 200/230/460 |
| Motor power | HP | 1.5 | 1.5 | 3 | 5 | 10 |
| Ratet rotational speed, 60 Hz | rpm | 3600 | 3600 | 3600 | 3600 | 3600 |
| Oil filling for gear box, - vertical flow - horizontal flow | qt | .75 | .75 | 1.10 | 2.10 | 4.20 |
| | qt | .55 | .55 | 0.75 | 1.30 | 2.10 |
| Oil filling for shaft seal housing for vertical and horizontal flow | qt | .74 | .74 | 1.3 | 1.9 | 1.9 |
| Weight WA/WAU | lbs | 177/185 | 188/196 | 283/294 | 486/497 | 883/896 |
| Connecting flanges | ANSI | 3" | 3" | 3" | 4" | 6" |
| Permissible ambient temperatures | °F | 54 - 104 | | | | |

Ref.-No.

| | | | | | | |
|-----------|--|--------|--------|--------|--------|--------|
| RUVAC AS | | 917 10 | 917 20 | 917 30 | 917 40 | 917 50 |
| RUVAC WAU | | 917 11 | 917 21 | 917 31 | 917 41 | 917 51 |

Dimensions in inches for RUVAC WA and WAU (US-Versions), see drawing on page 6

| Type | DN | DN ¹²⁾ | a | a1 | a2 | a3 | a4 | a5 | a6 | a7 | a8 | b | b1 |
|-------------|--------|-------------------|---------------------------------|----------------------------------|----------------------------------|---------------------------------|----------------------------------|---------------------------------|----------------------------------|---------------------------------|----------------------------------|---------------------------------|----------------------------------|
| WA 151 | 3" ASA | 65 | 28 ³ / ₄ | 15 ³ / ₄ | 14 ¹¹ / ₃₂ | 17 ¹ / ₃₂ | 7 ³ / ₃₂ | 3 ¹³ / ₁₆ | 6 ⁷ / ₁₆ | 1 ³¹ / ₃₂ | 10 ³ / ₁₆ | 9 ²⁷ / ₃₂ | 11 ¹ / ₃₂ |
| WAU 151 | 3" ASA | 65 | 28 ³ / ₄ | 15 ³ / ₄ | 14 ¹¹ / ₃₂ | 17 ¹ / ₃₂ | 7 ³ / ₃₂ | 3 ¹³ / ₁₆ | 6 ⁷ / ₁₆ | 1 ³¹ / ₃₂ | 10 ³ / ₁₆ | 9 ²⁷ / ₃₂ | 11 ¹ / ₃₂ |
| WA/WAU 251 | 3" ASA | 65 | 31 ³ / ₁₆ | 15 ¹⁵ / ₁₆ | 14 ³ / ₈ | 17 ¹ / ₃₂ | 8 ³ / ₈ | 4 ²³ / ₃₂ | 7 ² / ₃₂ | 1 ³¹ / ₃₂ | 11 ⁷ / ₁₆ | 9 ²⁷ / ₃₂ | 10 ⁵ / ₈ |
| WA/WAU 501 | 3" ASA | 65 | 36 ³ / ₈ | 19 ¹ / ₈ | 17 ²³ / ₃₂ | 17 ¹ / ₃₂ | 9 ⁷ / ₁₆ | 6 ³ / ₃₂ | 8 ¹⁹ / ₁₃₂ | 1 ³¹ / ₃₂ | 12 ²³ / ₃₂ | 12 ³ / ₃₂ | 11 ²⁵ / ₃₂ |
| WA/WAU 1001 | 4" ASA | 100 | 42 ³ / ₈ | 22 ¹ / ₁₆ | 20 ¹⁸ / ₃₂ | 2 ¹ / ₃₂ | 11 ¹³ / ₁₆ | 7 ³ / ₃₂ | 10 ⁵ / ₁₆ | 1 ³¹ / ₃₂ | 16 ¹⁵ / ₁₆ | 14 ² / ₃₂ | 13 ⁷ / ₈ |
| WA/WAU 2001 | 6" ASA | 150 | 52 ³ / ₄ | 31 ¹ / ₂ | 29 ⁵ / ₃₂ | 1 ¹ / ₁₆ | 14 ¹⁷ / ₃₂ | 8 ² / ₃₂ | 12 ⁷ / ₃₂ | 1 ³¹ / ₃₂ | 19 ²⁵ / ₃₂ | 18 | 20 ¹ / ₄ |

| Type | b2 | b3 | b4 | b5 | b6 | b7 ¹⁾ | h | h1 | h2 | h3 | h4 | h5 ¹⁾ | h6 |
|-------------|---------------------------------|----------------------------------|----------------------------------|----------------------------------|--------------------------------|----------------------------------|----------------------------------|----------------------------------|----------------------------------|----------------------------------|----------------------------------|----------------------------------|---------------------------------|
| WA 151 | 8 ¹⁵ / ₃₂ | 11 | 9 ⁷ / ₁₆ | 6 ²⁹ / ₃₂ | 1 ⁵ / ₁₆ | 12 | 11 ¹³ / ₁₆ | 6 ⁵ / ₁₆ | 11 ¹ / ₃₂ | 7 ³ / ₃₂ | 12 ¹ / ₁₆ | 14 ³ / ₁₆ | 13 |
| WAU 151 | 8 ¹³ / ₁₆ | 11 | 9 ²⁵ / ₃₂ | 7 ¹ / ₄ | 1 ⁵ / ₁₆ | 12 | 11 ¹³ / ₁₆ | 6 ⁵ / ₁₆ | 11 ¹ / ₃₂ | 7 ³ / ₃₂ | 12 ¹ / ₁₆ | 14 ³ / ₁₆ | 13 |
| WA/WAU 251 | 8 ⁹ / ₃₂ | 11 | 9 ¹ / ₁₆ | 6 ¹ / ₁₆ | 1 ⁵ / ₁₆ | 12 | 11 ¹³ / ₁₆ | 6 ⁵ / ₁₆ | 11 ¹ / ₃₂ | 7 ³ / ₃₂ | 12 ¹ / ₁₆ | 14 ³ / ₁₆ | 13 |
| WA/WAU 501 | 9 | 12 ¹⁹ / ₃₂ | 10 ² / ₃₂ | 7 ²⁹ / ₃₂ | 1 ⁵ / ₁₆ | 15 ¹¹ / ₃₂ | 13 ³ / ₈ | 7 ³ / ₃₂ | 12 ¹⁹ / ₃₂ | 7 ⁵ / ₈ | 13 ²³ / ₃₂ | 16 ¹⁵ / ₁₆ | 14 ⁹ / ₁₆ |
| WA/WAU 1001 | 10 ³ / ₃₂ | 14 ⁹ / ₁₆ | 12 ¹⁹ / ₃₂ | 9 ¹ / ₁₆ | 1 ⁵ / ₁₆ | 19 ⁵ / ₁₆ | 15 ¹⁹ / ₃₂ | 8 ⁵ / ₁₆ | 14 ⁹ / ₁₆ | 8 ¹⁵ / ₁₆ | 16 ⁵ / ₁₆ | 20 ¹⁵ / ₁₆ | 16 ³ / ₄ |
| WA/WAU 2001 | 15 ³ / ₈ | 18 ¹ / ₈ | 16 ¹⁵ / ₃₂ | 11 ¹¹ / ₃₂ | 1 ⁵ / ₁₆ | 25 | 20 ⁷ / ₈ | 11 ¹³ / ₁₆ | 18 ¹ / ₈ | 13 ¹³ / ₁₆ | 22 ³ / ₄ | 29 ² / ₃₂ | 21 ⁵ / ₁₆ |

¹⁾ for RUVAC WAU only

²⁾ according to DIN 2501, ND 6 (in metric system)

1.4 Accessories

| | Cat.-No. |
|--|------------|
| Set of gaskets | |
| WA/WAU 151/251 | 194 60 |
| WA/WAU 501 | 194 64 |
| WA/WAU 1001 | 194 68 |
| WA/WAU 2001 | 194 72 |
| Oil pressure switches | |
| (for WA/WAU 1001/2001 only) | 194 82 |
| Oil drain facility (M 16 x 1,5) | |
| – with straight drain coupling | 190 02 |
| – with right-angled drain coupling | 200 14 271 |
| Diaphragm pressure switch SM 42 | |
| 0,5 to 6 mbar | 164 05 |
| 5 to 50 mbar | 164 06 |
| 40 to 400 mbar | 164 07 |
| Accessories for mounting SM 42 | |
| Adapter | 168 39 |
| Right-angle bend DN 20 KF | 184 32 |
| Centering ring DN 20 KF, 2x | 183 22 |
| Clamping ring DN 20 KF, 2 x | 183 42 |
| Pressure switch PS 114 | 160 01 |
| Pressure switch PS 115 | 160 04 |
| Pressure switch PS 112 Ex | 160 91 |
| Accessories for mounting PS 114/115 | |
| Adapter | 168 40 |
| Right-angle bend DN 16 KF | 184 36 |
| Centering ring DN 16 KF, 2 x | 183 26 |
| Clamping ring DN 16 KF, 2x | 183 41 |
| Contact amplifier SV 110 | |
| – 230 V | 160 78 |
| Oil N 62*,5l | 177 02 |
| Oil HE-200*,1 gal | 98-198-007 |

* N 62 is an oil grade of Leybold Cologne, and HE-200 is an oil grade of LHVP Export.
They are interchangeable.
For other quantities, see catalogue.

2 Transportation and Storage

Roots pumps are heavy machines (> 70 kg) made of cast iron and thus should only be lifted using suitable lifting equipment tied to the crane eye (8/3) provided for this purpose.

Caution Before transporting the pump always drain out the oil from of the bearing spaces (see Section 5.2). Screw the oil-drain plug with its gasket back in and wipe any oil droplets off from the casing. It will not be required to drain out the oil from the shaft seal housing (oiler). The pump should be transported and stored in a horizontal position (5 ° max. tilt with respect to its longitudinal axis). Otherwise there is the danger that oil from the bearing chambers may enter the pump chamber, even before the pump is filled with oil for the first time.

Caution The pump must only be moved and installed in its horizontal orientation. Otherwise the oil in the shaft seal housing (oiler) may spill out.

When shelving the pump for a longer period of time, the oil should be drained out and you should seal off the flanges of the pump with a piece of foil or the cardboard discs initially supplied with the pump using the collars. Place a bag with desiccant in the pump chamber, if required.

The area of the motor (fan and slits at the flange of the motor) must be protected against dust and dripping water.

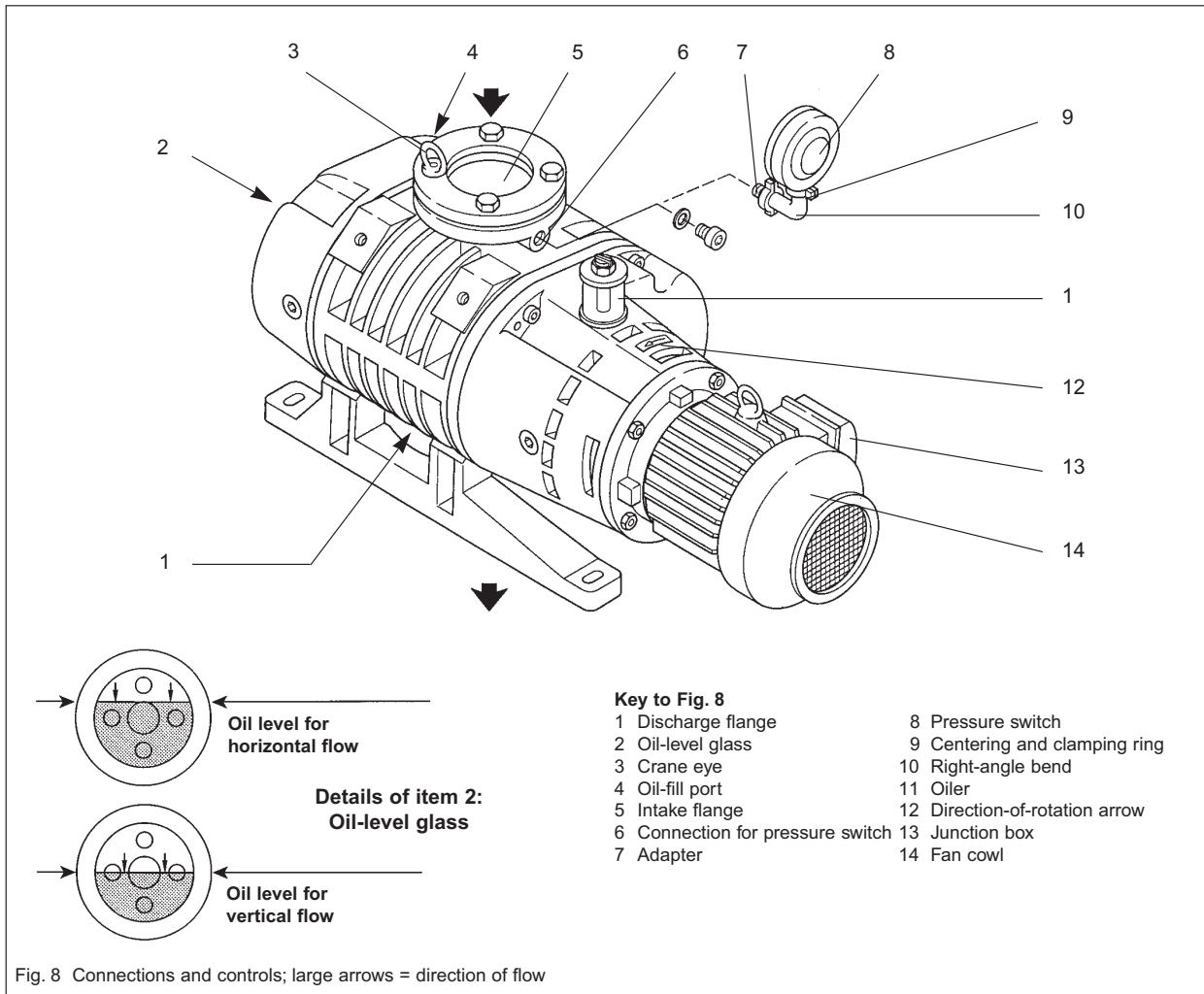

3 Installation and Connection

Caution Only fill in the oil **after** having installed the pump.

3.1 Installation

Install RUVAC pumps on a flat, horizontal surface (5° max. tilt with respect to the longitudinal axis).

Caution If the pump is tilted by more than 5°, lubricant may enter the pumping chamber from the gear chambers.

Keep the air intake and exhaust ducts for cooling the motor unobstructed (for minimum clearance with respect to the fan cowl, see Fig. 5).

The pump's ambient temperature should be between 12 °C and 40 °C. Lower temperatures hamper run-up; higher ones shorten the oil change intervals and may lead to greater wear.

Special oil for operation at temperatures below 12 °C is available upon request.

Secure the pump.
Four holes in the feet are provided for this purpose.

Caution When bolting the feet down, make certain that there is no stress or twist on the pump casing. Stress on the pump can change the close tolerances between the impellers and the pump casing and may result in damage to the pump (use washers to equalise).

Warning Since compensation elements must be attached to the flanges on the suction and pressure sides, the screws for attachment of the feet must always be fitted and tightened well.



Use the following screws:
RUVAC 151/251/501: 4 x M 12
RUVAC 1001/2001: 4 x M 16

3.2 Filling in of the Lubricants

The housing for the shaft seal and the oiler (10/1) are filled with N 62 oil when the pump is supplied. The oil level must be visible in the oiler.

Caution Correct oil level: $\frac{1}{3}$ of the oiler must be filled when the pump is cold. Top up oil as required.

The lubricant needed for running the pump is supplied in a separate container.

Unscrew the oil-fill plug (10/8) and add oil.

An oil **without additives** and of viscosity class ISO VG 100 (formerly SAE 30) must be used for the pump. We recommend our special oils N 62 or HE-200. Please consult us if you intend to run the pump with other oils or special lubricants.

When the pump is not running the correct oil level is:

- for vertical flow of the pump in the center
- for horizontal flow it is 6 mm above the center of the oil-level glass (8/2).

Caution If the oil level is too low, the bearings and gearwheels are not lubricated adequately; if it is too high oil may enter the pumping chamber.

Clean the oil-fill port and screw the plug back in using a gasket which is in perfect condition.

The oil-fill port must be sealed air-tight. Entry of air from the outside may cause oil-containing gas to enter the pumping chamber via the impellers seals.

3.3 Electrical Connections

Warning Disconnect the mains before doing work on the wiring.
Electrical connections must be made by a skilled electrician as defined by VDE 0105 and in accordance with the guidelines of VDE 0100.



For proper connection, a suitable motor protection switch must be used. Set the switch in accordance with the rating on the motor nameplate.

Connect the pump to the correct mains voltage through the terminals provided in the junction box (8/13).

Always provide an uninterrupted connection for the protective ground conductor  connecting it in a professional manner. Never leave the protective ground conductor for the pump unconnected.

Do not link control circuits to the power circuit of the motor. Observe the wiring diagram of Fig. 9.

Caution The WA/WAU pumps are **not** suitable for operation in connection with frequency converters. The max. permissible speed is 3,600 rpm regardless of the size of the pump.

After connecting the motor and every time you alter the wiring, check the direction of rotation.

Never allow the pump to run in the wrong direction or with open flanges for a longer period of time.

An arrow (8/12) on the coupling housing shows the correct direction of rotation for the motor shaft. To check rotation, switch on the motor briefly and observe the direction of impeller rotation through the pump's intake and then immediately switch off again.

Warning Wear protective goggles for protection against particles which may be forced out of the flange opening. Keep your hands away from the flange opening.



The impellers should move up from the center and drop down to the side.

If this is not the case, disconnect the pump from the mains and interchange two mains phases.

Even if the pump has been already firmly connected to the piping, you may determine the direction of rotation.

For this, evacuate the vacuum system down to a pressure below 20 mbar with the aid of the backing pump. Then switch on the RUVAC briefly; now the pressure must drop. If the pressure increases or remains constant, the RUVAC is turning in the wrong direction.

Then rewire as described above.

The RUVAC can be automatically switched on and off via a contactor using a pressure switch and the contact amplifier SV 110 (see Section 1.4).

The pressure switches SM 42 or PS 114/115 are set to a fixed threshold in our factory. Please specify the switching threshold when ordering.

The contact amplifier is identical for all pressure switches.

Pressure switches and contact amplifiers with explosion hazard protection are available upon request.

After removing a screw plug, the pressure switch (8/8) together with an adapter (8/7) and a right-angle bend (8/10) can be mounted on the bore (8/6).

When doing so, ensure proper sealing and air-tight installation.

It is advisable to mount the switch vertically to reduce the entry of contaminants.

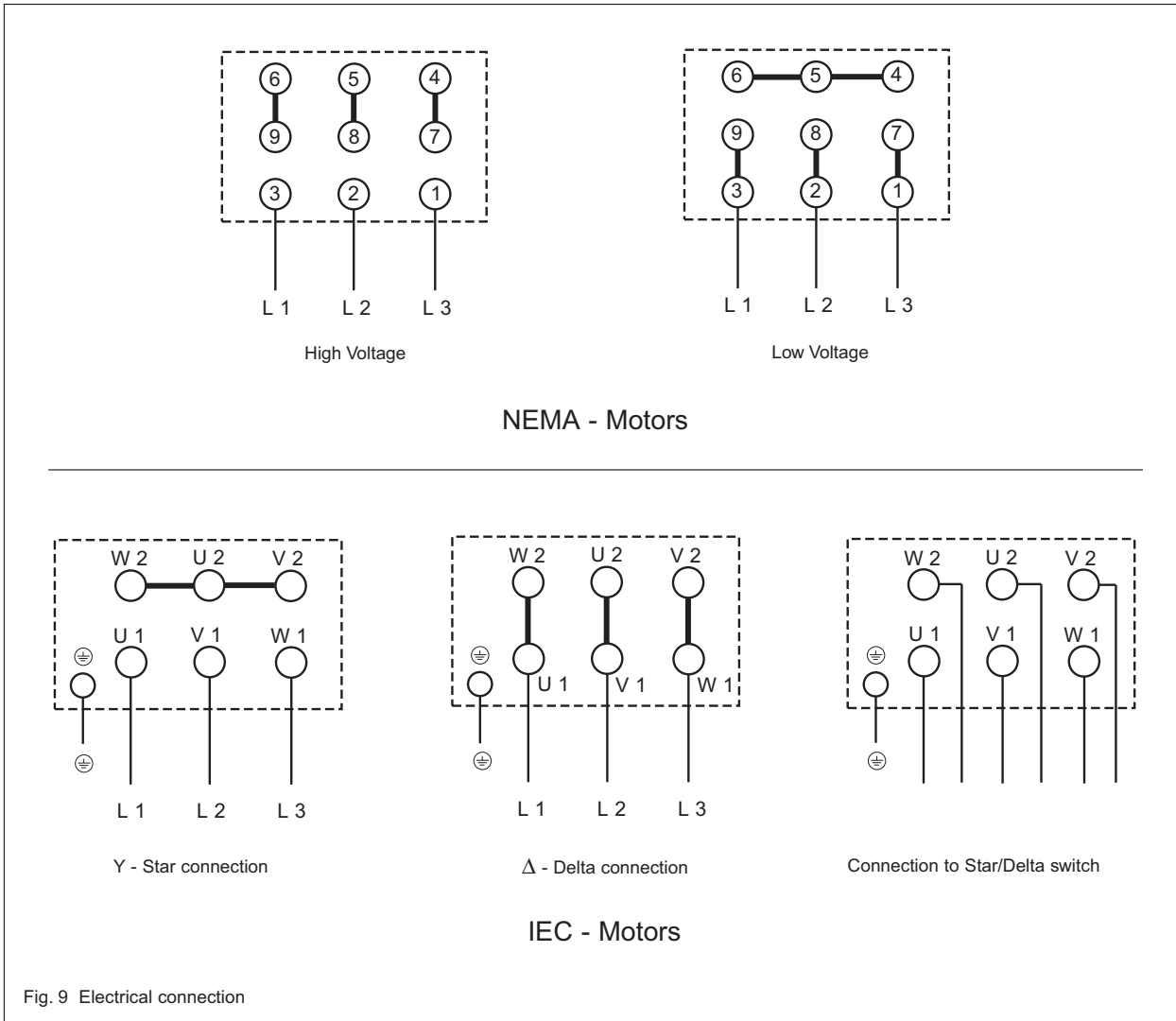

3.4 Connection of the Flanges

Caution Already small quantities of liquids (from the vacuum chamber or the piping) can lead to liquid damages within the pump. These may lead to a deformation of the impellers and may entirely destroy the pump. Suitable protective measures should be provided as required in the piping on the suction side (separator, T-piece).

Warning The RUVAC WA/WAU pumps have **not been designed** to pump ignitable or explosive mixtures without additional protection. If the pumps are none-the-less to be used under such conditions, the customer himself must ensure that proper measures for the purpose of protection against explosions (pressure monitor, flame arresters etc.) are introduced, in line with the requirements of the applicable laws. Consult us for advice.



The dirt-trap which is supplied with the pump should always be fitted into the intake flange when there is the possibility of contaminants entering the pump coming from the vacuum chamber or the piping.

Even with clean vacuum processes, contaminants from the system may enter upon initial start-up. Depending on the operating conditions, the dirt trap may reduce the pumping speed of the pump.

Observe the maintenance information provided in Section 5.5.

If not already done, remove the protective shipping covers, cardboard pieces, foil or packing flanges from the flanges (8/5) and (8/1).

We recommend that you retain the shipping flanges of the pumps in case you want to store the pump at a later date.

Clean the flanges and check that the sealing surfaces are in perfect condition.

Flange the pump to the vacuum system.

Caution Don't place any stress on the pump casing when installing the intake and discharge lines. Fit compensation elements in order to avoid such stresses. When attaching the pump directly (without bolting down the feet) to the forevacuum pump, you must always use on the pressure side the full number of screws defined by the flange standard (ISO-K, DIN or ASA) whereby these must comply with the demanded property class rating. You must also check whether the backing pump is rigid and stable enough to support the load of the RUVAC pump in each case.

4 Operation

4.1 Start-up

Check the pump motor's direction of rotation and the oil level in the bearing spaces (see Section 3.2 and 3.3).

RUVAC WAU

The RUVAC WAU can be started together with the backing pump at atmospheric pressure.

It is protected against excessively high pressure differentials by a bypass line.

RUVAC WA

Do not switch on the RUVAC WA until the backing pump has evacuated the vacuum vessel to the cut-in pressure (see Technical Data, Section 1.3).

For processes in which condensable vapours are pumped, it is advisable to evacuate the vacuum vessel via a roughing line to the cut-in pressure. Electrically switch on the Roots pump together with the backing pump and cut it in upon reaching the cut-in pressure. The initial bypassing of the Roots pump serves to prevent condensation of vapours in the cold pump.

The permissible cut-in pressure depends on the ratio between the Roots pump and the backing pump. It can be calculated according to the following formula:

$$p_E = \frac{p_{\max}}{k_{th} - 1}$$

p_E = Cut-in pressure

p_{\max} = Maximum permissible pressure differential (see Technical Data)

k_{th} = Theoretical compression ratio
= nominal pumping speed of Roots pump /
pumping speed of backing pump

Example:

Pump combination:

RUVAC WA 501 / SOGEVAC SV 100

$$k_{th} = \frac{505 \text{ m}^3 \times \text{h}^{-1}}{100 \text{ m}^3 \times \text{h}^{-1}} \approx 5$$

$$p_E = \frac{80 \text{ mbar}}{5 - 1} = 20 \text{ mbar}$$

With small vacuum vessels, the maximum permissible pressure differential can be briefly exceeded (max. 3 min) upon start-up. If a pressure switch has been installed, do not set it to this higher pressure because it will fail to protect the pump against overload in the event of a greater gas quantity.

It is advisable to switch the RUVAC WA on and off via a pressure switch to ensure that it runs only in the permissible pressure range.

4.2 Operation

Warning Do not operate the pump without having connected the flanges to a vacuum system. The screws of the flanges on the suction and the pressure side must not be loosened in the presence of a vacuum even if the pump is **not** running.



During operation of the RUVAC, check the oil level and the condition of the oil in the oil level glass and the oiler from time to time. Correct as required (see Section 5.2 and 5.3). Normally, the oil N 62 or HE-200 is light-brown. If it turns dark, this is a sign of early ageing due to excessively high temperatures.

Caution Run the Roots pump exclusively under the operating conditions for which it has been designed. Any modification of the operating parameters (e. g. intake pressure, intake temperature, ratio between Roots pump and backing pump) for a longer period may place an inadmissible thermal load on the pump. Increases in temperature which are not compensated by taking suitable measures may damage the Roots pump and/or the backing pump.

Warning During normal operation temperatures exceeding 80 °C may occur at the discharge port, the oil chambers and the line on the pressure side. When touching these there is the danger of receiving burns. Note the labels on the pump.



Warning Never open the oil-fill or oil-drain screw (Fig. 11) in the presence of a vacuum or while the pump is running. There is the danger that oil may squirt out.



The oil level for the shaft seal housing must always be visible in the oiler (10/1). The correct oil level is $\frac{1}{3}$ of the height of the oil when the pump is cold $\frac{1}{2}$ of the height of the oiler when the pump is warm. Top up any oil as required.

For this we recommend that you use N 62 or HE 200 oil. If it is required to top up oil very often, it is quite likely that a shaft seal is faulty (see Section 5.8).

4.3 Shutdown and Storage

Separate the Roots pump from the vacuum system by closing the corresponding valve. First switch off the Roots pump, then the backing pump.

After working with corrosive gases, the system should be vented with dry protective gas (e.g. N_2) to prevent corrosion during standstill.

When shutting down the pump and removing it from the system, it is advisable to seal the connecting flanges tightly.

Warning Before removing pump from the vacuum system, disconnect it from the mains supply.



Take note of possibly contaminated pumps.



Observe all safety regulations.

For transportation and storing of the pump, observe the information provided in Section 2.

4.4 Changing from Vertical to Horizontal Flow

The RUVAC WA/WAUs are supplied as standard for vertical flow unless you specifically request horizontal flow. Moreover, the pump may be converted from one flow direction to the other.

For this proceed as follows:

Unscrew the sealing screws (10/6 and 10/7) and drain out the oil from the side chambers.

Next, screw in the magnetic sealing screw (10/6) using a perfect gasket in to the opening at the side and screw in a sealing screw (10/7) using a perfect gasket into the lower opening.

Unscrew sealing screw (10/3) and drain the oil out of the shaft seal housing. Then screw in sealing screw (10/3) using a gasket which is in perfect condition.

Unscrew the feet of the pump, turn the pump by 90° and fit the feet once more taking account of the changed direction of flow.

Caution The longitudinal axis of the pump must remain horizontal so that no residual lubricant can flow from the side chambers into the pumping chamber.

Unscrew oiler (10/1) and sealing screw (10/2). Screw in the oiler from the top using a perfect gasket and screw in the sealing screw from the side also using a perfect gasket.

Fill in the oil for the side chambers at (10/8) and the oil for the shaft seal housing at the oiler (10/1).

If a pressure switch has been installed, turn it so that it again points vertically upwards.

The valve in the pressure balance line of the RUVAC WAU is designed to work with both vertical and horizontal flow of the pump.

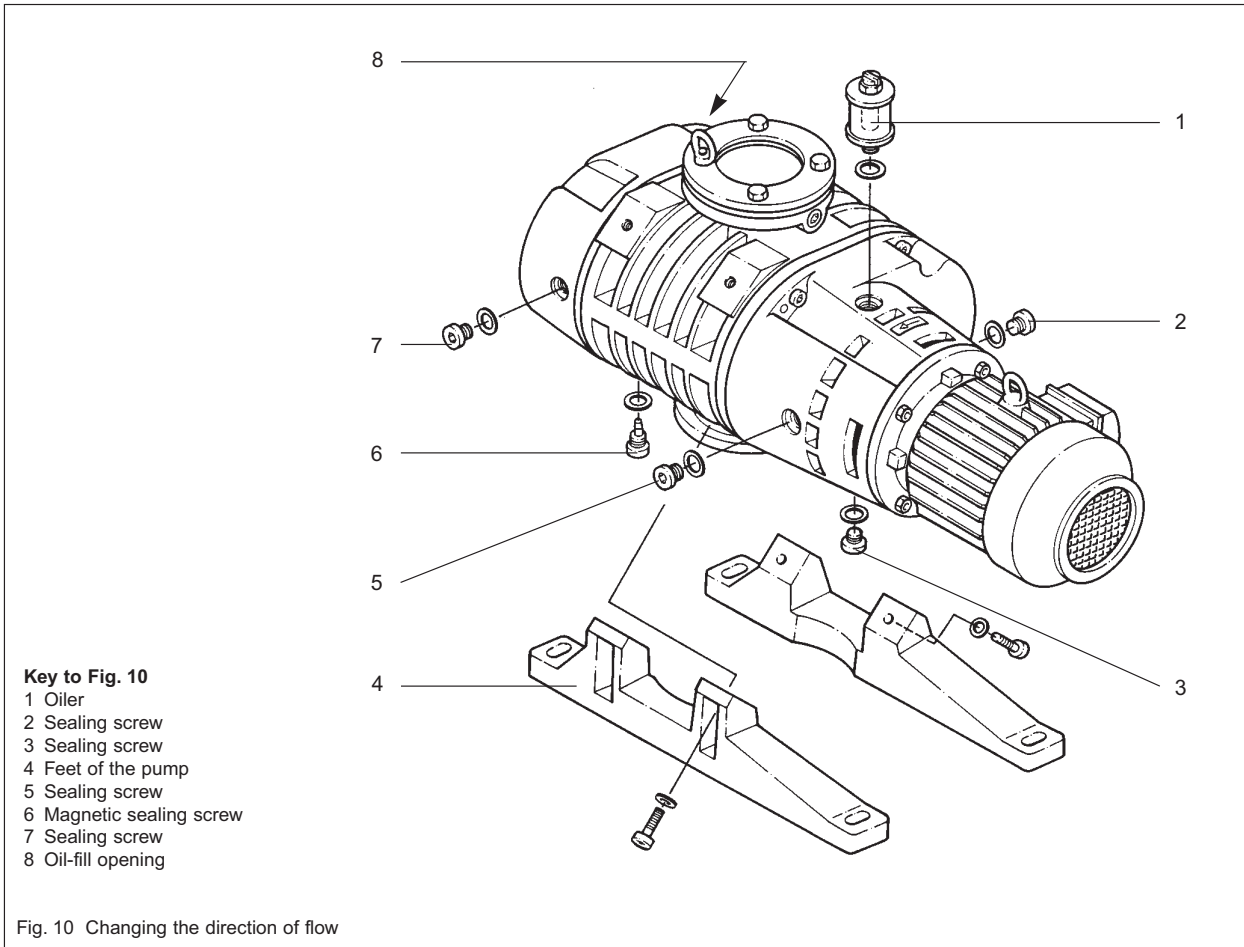

5 Maintenance

5.1 Safety Information

The safety information given in the following applies to all maintenance work.

Warning

Disconnect the electrical power before disassembling the pump and vent the pump to atmospheric pressure. Make absolutely sure that the pump cannot be accidentally started.



If the pump has been pumping harmful substances, determine the nature of hazard and introduce suitable safety measures.



When drying or blowing out the pump with compressed air you must – as a rule – wear safety goggles.



Observe all safety regulations!



If you send a pump to LEYBOLD for repair please indicate any harmful substances existing in or around the pump. For this use the “Declaration of Contamination” form which has been prepared by us and which we will provide upon request.

Any pump received by us without, or an incompletely filled in declaration will delay the repair.

Caution

When shipping contaminated pumps which require approval by the authorities, you must observe the applicable packaging and shipping regulations.

All maintenance and cleaning work described in this section must be carried out only by suitably trained personnel.

When disposing of used lubricants please observe the relevant environmental regulations.

Improper maintenance or repairs may affect the service life and performance of the pump, and cause problems when filing warranty claims.

Advanced repair work not described here should be left to the LEYBOLD service.

We would like to point out that LEYBOLD offers training courses on the maintenance, repair, and troubleshooting of RUVAC pumps. Further details are available on request.

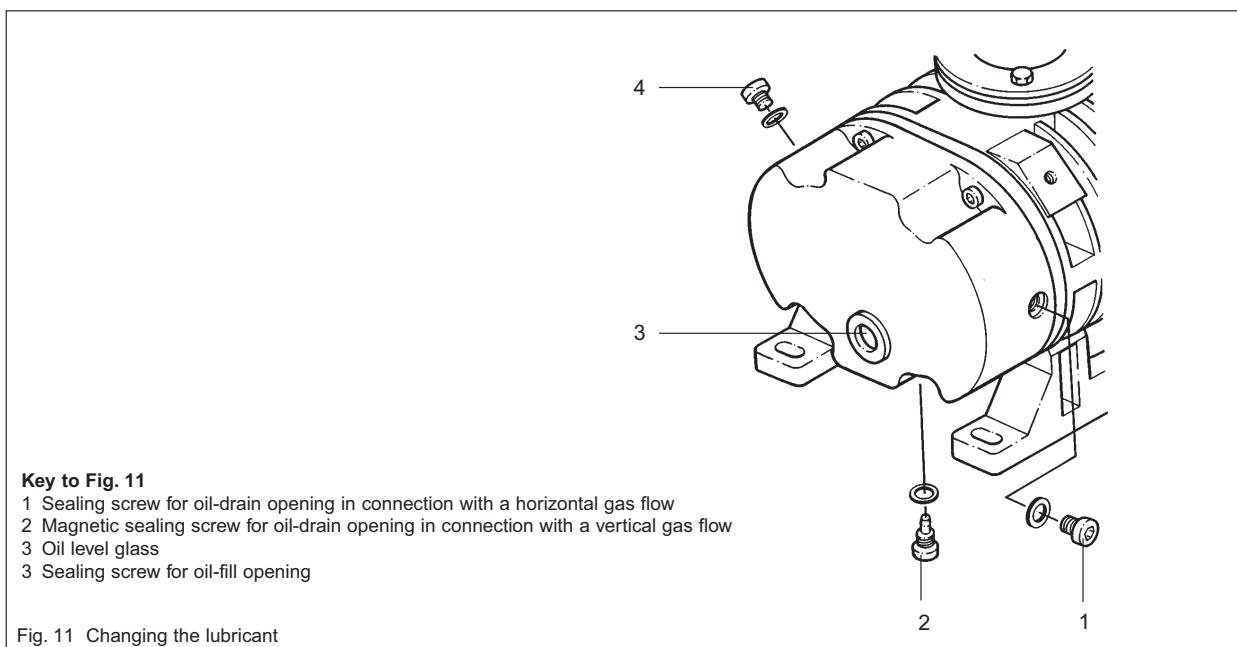

5.2 Oil Change/Gear Box

Warning Observe all safety information provided in Section 5.1.



Very little oil is consumed by wear in the bearings and the gear under clean operating conditions. We recommend that you change the oil after the first 500 hours of operation to remove any wearing residue.

Then, under normal operating conditions, change the oil after every 3,000 hours of operation.

Change the oil more frequently when pumping corrosive vapours or large amounts of dust or when cycling frequently from atmospheric to working pressure.

Under such operating conditions it is recommended to regularly check the neutralisation value (to DIN 51 558) based on a sample of oil. If the neutralisation value exceeds 2, an oil exchange will be required.

Warning Before removing the oil-drain or oil-fill plug always **switch off** the pump first and vent to atmospheric pressure.



When the pump has become warm during operation, the casing and the oil temperature may exceed 80 °C.



Leave the pump to cool down. Always wear protective gloves also to protect yourself against aggressive residues in the oil.



To simplify the process and also for safety reasons we recommend the use of our oil-drain facility (see Section 1.4).

Unscrew the oil-drain screws (11/2) or (11/1) and the oil-fill screw (11/4) and drain the oil.

Clean the sealing surface and firmly reinstall the oil-drain screw (11/2) or (11/1) using a gasket which is in perfect condition. Wipe off any oil residues from the casing.

Fill in new oil.

For oil quantities and ordering data see Sections 1.3 and 1.4.

Make sure to use the right kind of oil.

An oil **without additives** of viscosity class ISO VG 100 (formerly SAE 30) must be used for the pump.

Caution We recommend the use of our special oil N 62 or HE-200.

Please consult us if you intend to run the pump with other oils or special lubricants.

At **vertical flow** the correct oil level is at the **center of the oil-level glass (8/2)** when the pump is **not running**.

At **horizontal flow** the correct oil level must be **6 mm above the center of the oil-level glass (8/2)**.

Caution If the oil level is too low, the bearings and gearwheels are not lubricated adequately; if it is too high, oil may enter the pumping chamber.

Clean the oil-fill port and reinstall the screw (11/5) using a gasket which is in perfect condition. Wipe off any oil residues from the casing.

Caution The oil-fill port must be sealed air-tight. In the presence of a vacuum, the entry of air may cause oil-containing gas to enter the pumping chamber via the impeller seals.

5.3 Oil change/shaft seal housing

Warning Observe all safety information provided in Section 5.1.



The oil in the shaft seal housing should be changed every 3,000 operating hours.

Unscrew the oil-drain screw (10/3) under the shaft seal housing, drain out the oil and screw in the oil-drain screw using a gasket which is in perfect condition.

Fill in fresh oil at the oiler (10/1). The oil level for the shaft seal housing must be visible in the oiler.

Maximum level

- when the pump is **warm** = $1/2$ of the height of the oiler
- when the pump is **cold** = $1/3$ of the height of the oiler.

Wipe off any oil residues from the casing.

5.4 Cleaning the Fan Cowl and the Cooling Fins

Warning Observe all safety information provided in Section 5.1.



The slits in the fan cowl (8/14) as well as the fins on the motor and on the pump may be contaminated depending on humidity conditions and the degree of contamination in the ambient air.

In order to ensure a sufficient air flow for the motor and the pump's casing, the grid of the fan cowl must be cleaned with a clean brush when contaminated.

Any coarse dirt must be removed from the fins on the motor and the pump.

5.5 Cleaning the Dirt Trap

Warning Observe all safety information provided in Section 5.1.



A wire-mesh sieve is located in the intake port (8/5) to collect foreign objects. It should be kept clean in order to avoid a reduction of the pumping speed.

To do so, take off the intake line. Remove the dirt trap from the intake flange and rinse it using a suitable solvent. Then thoroughly dry it with compressed air. If the dirt trap is damaged, replace it.

5.6 Cleaning the Pumping Chamber

Warning Observe all safety information provided in Section 5.1.



Under dirty operating conditions, contaminants may be deposited in the pumping chamber or on the impellers. After removing the two connecting lines, the contaminants can be blown out with dry compressed air or flushed out with a suitable solvent.

Contaminants that cannot be blown or flushed out, can be removed completely from the pumping chamber with a wire brush, metallic sponge or scraper.

Then change the oil.

Warning During cleaning, the impellers must be turned only by hand.



Achtung The loosened deposits must not remain in the pump. After cleaning, check the pump by slowly turning the impellers by hand. They should move freely and without any resistance.

Generally, the Roots pump does not need to be disassembled. If necessary, this should only be done by our after-sales service.

5.7 Cleaning the Valve of the Pressure Balance Line

Observe all safety information provided in Section 5.1.

Warning



Remove the screws and take off the cover (12/1) with O-ring (12/2).

Take out the spring (12/4).

Remove the valve disk (12/6) with O-rings (12/5) and (12/7).

If the bushing (12/3) is damaged, pull it out of the valve disk and replace it.

Clean all parts or replace them if necessary. Reassemble in the reverse sequence. When doing so, check the O-rings for leak-tightness and replace if found faulty. Finally a leak test should be run.

5.8 Exchanging the Shaft Seals

Observe all safety information provided in Section 5.1.

The shaft feedthrough of the RUVAC WA/WAU is sealed with two shaft seals. In order to reduce wear on the shaft these shaft seals run on a bushing.

A dropping oil level in the oiler (10/1) is a sign for malfunctioning shaft seals.

When the oil level in the oiler drops and when no oil appears under the shaft seal housing, it is likely that the inner shaft seal is faulty. In this case the oil flows from the shaft seal housing into the bearing spaces of the pump thereby creating in the bearing spaces an unacceptably high oil level. In such a case the pump must be switched off immediately and it must be repaired.

When the oil level in the oiler drops and when oil appears under the shaft seal housing, it is likely that the outer

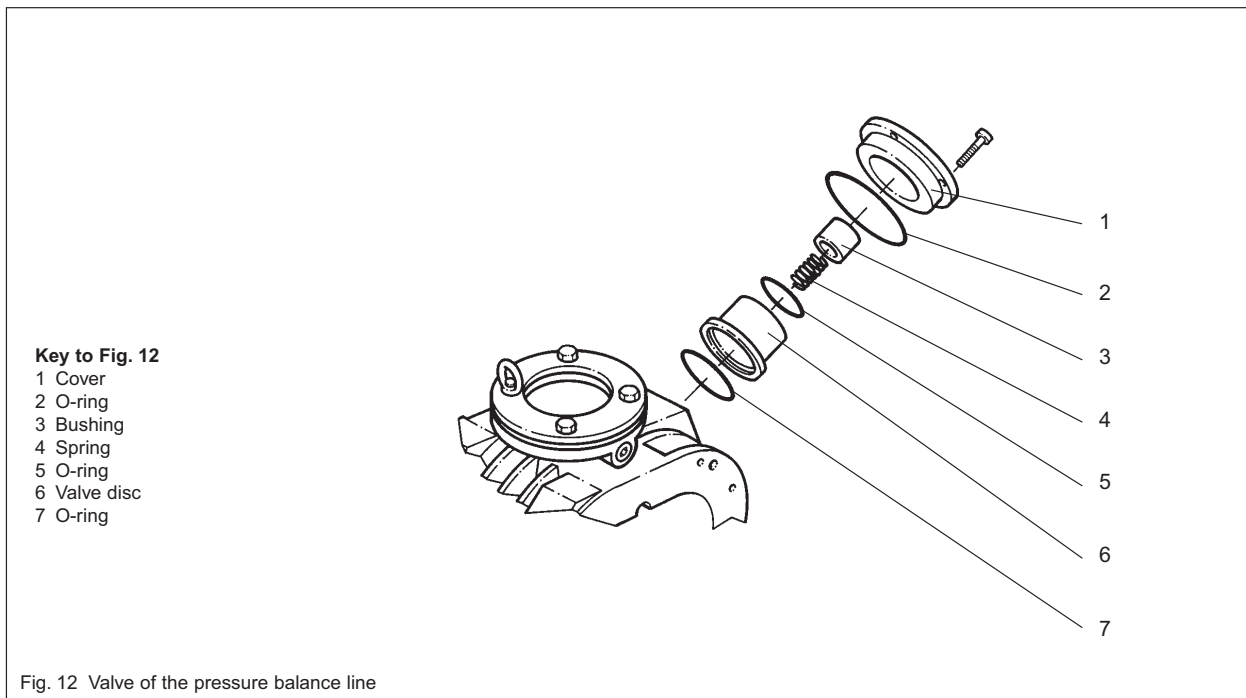

shaft seal is malfunctioning. If the oil loss is only slight, the pump may still be operated for some time, provided the lost oil is topped up regularly.

Warning



Collect the oil which drips out under the motor. There is the danger that someone may slip.
Have the pump repaired.

5.8.1 Required Special Tools

(see Fig. 14)

1. Two-armed puller for the bushing of the RUVAC WA/WAU 151, 251 and 501. A suitable puller must be adapted according to Fig. 14/c. In the case of the RUVAC 1001 and 2001 a commercially available puller will do.
2. Pulling device for the coupling of the RUVAC WA/WAU 151, 251 and 501 according to Fig. 14/b.
3. Shaft seal driver according to Fig. 14/b.

The shaft seal drivers can be ordered at LHVP Export in the USA.

Order No.:

WA/WAU 151/251/501 722 81027

WA/WAU 1001/2001 722 81028

5.8.2 Preparations

Warning



Unscrew sealing screw (13/21) with the gasket, drain the oil out from the shaft seal housing and screw the sealing screw back in using a gasket which is in perfect condition.

Support the motor so that it can not drop.

Unscrew the nuts (13/18) and remove the motor with the coupling piece (13/17).

Remove protection tube (13/16). Remove the coupling element (13/15).

Unscrew screw (13/19) with the disc and pull off coupling piece (13/14) using the puller (Fig. 14/a).

Remove key (13/13).

Unscrew screws (13/20).

5.8.3 RUVAC WA/WAU 151, 251, 501

Pull the shaft seal housing (13/8) out. Forcing threads are provided on the shaft seal housing for this purpose.

Take the O-ring (13/4) out of the flange of the coupling.

Use the puller (Fig. 14/c) to pull the bushing (13/3) off from the shaft.

Take the O-ring (13/2) from the shaft.

Take the O-ring (13/5) from the housing. Remove securing ring (13/6).

Pull out the shaft seal (13/7).

Take out snap ring (13/12) and felt ring (13/11).

Take out shaft seal (13/10). Remove securing ring (13/9).

It is strongly recommended always to exchange the shaft seals, the bushing and the felt ring against new parts. Clean all other parts and replace them as required.

Fit securing ring (13/9).

Use shaft seal driver (14/b) to drive the shaft seal (13/10) down to the securing ring (13/9) (for position of the shaft seal refer to Fig. 13).

Fit felt ring (13/11) and snap ring (13/12).

Use shaft seal driver (14/b) to drive the shaft seal (13/7) down. Here the depth must be defined by the tool (for position of the shaft seal refer to Fig. 13).

Fit securing ring (13/6).

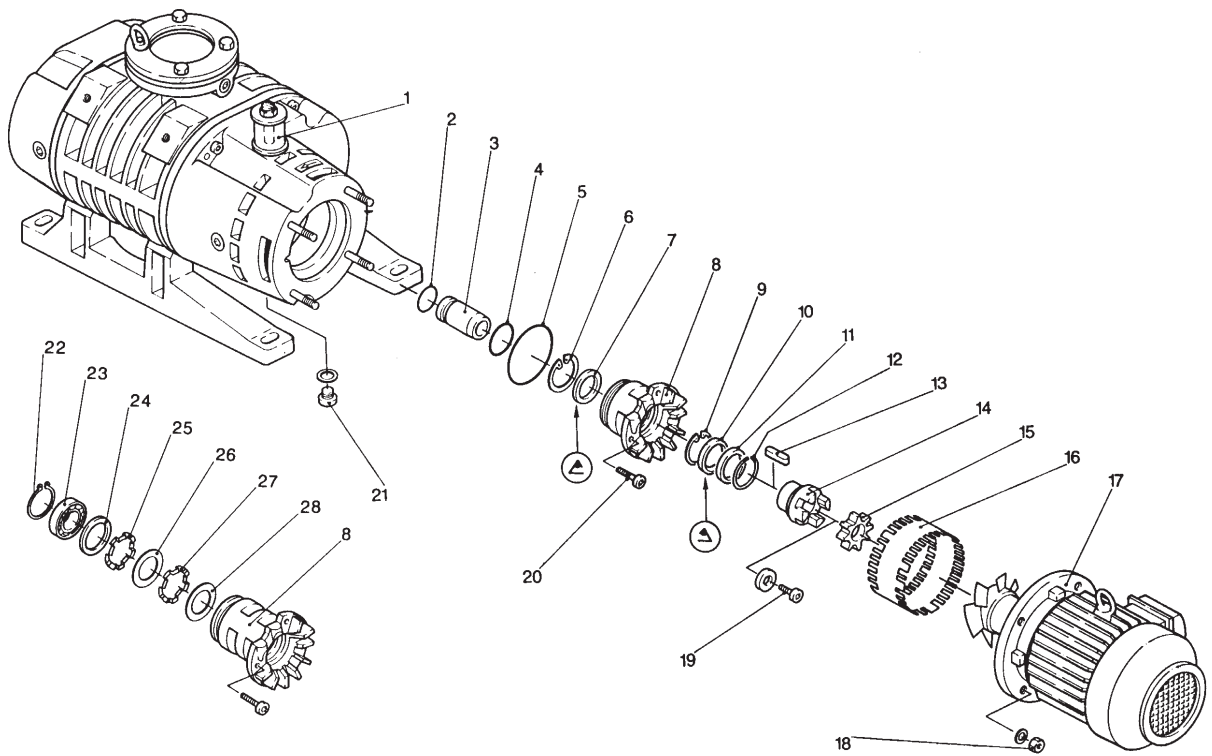

Key to Fig. 13

- | | |
|--|--|
| 1 Oiler | 15 Coupling element |
| 2 O-ring | 16 Protection tube |
| 3 Bushing | 17 Motor with coupling piece (other half) |
| 4 O-ring | 18 Nuts |
| 5 O-ring | 19 Screw |
| 6 Securing ring | 20 Screw |
| 7 Shaft seal | 21 Sealing screw (WA/WAU 1001 and 2001 only) |
| 8 Shaft seal housing | 22 Securing ring |
| 9 Securing ring (WA/WAU 151, 251 and 501 only) | 23 Ball bearing |
| 10 Shaft seal | 24 Spacing disc |
| 11 Felt ring | 25 Wave washer |
| 12 Snap ring | 26 Adjusting disc |
| 13 Key | 27 Wave washer |
| 14 Coupling piece (one half) | 28 Adjusting disc |

Fig. 13 Exchanging the shaft seal

Now reassemble the parts in the reverse order as for disassembly.

Before starting the pump, fill in the required amount of oil at the oiler (see Section 3.2).

5.8.4 RUVAC WA/WAU 1001, 2001

Use a puller to pull out shaft seal housing (13/8) and bushing (13/3) together.

Remove O-rings (13/4 and 13/2).

Pull the bushing out of the housing.

Take the O-ring (13/5) out of the housing. Remove securing ring (13/6).

Pull out shaft seal (13/7).

Pull out snap ring (13/12) and felt ring (13/11).

Remove shaft seal (13/10).

Remove securing ring (13/22). Pull out bearing (13/23).

Take out spacing disc (13/24), wave washers (13/25 and 13/27) as well as adjusting discs (13/26 and 13/28).

It is strongly recommended always to exchange the shaft seals, the bushing and the felt ring against new parts. Clean all other parts and replace them as required.

Place adjusting disc (13/28), wave washer (13/27), adjusting disc (13/26), wave washer (13/25) and spacing disc (13/24) into the housing.

Drive bearing (13/23) back in.

Fit securing ring (13/22).

Use shaft seal driver (14/b) to drive the shaft seal (13/10) down to the stop (for position of the shaft seal refer to Fig. 13).

Fit felt ring (13/11) and snap ring (13/12).

Use shaft seal driver (14/b) to drive the shaft seal (13/7) down.

Here the depth must be defined by the tool (for position of the shaft seal refer to Fig. 13).

Fit securing ring (13/6).

Now reassemble the parts in the reverse order as for disassembly.

Caution Before starting the pump, fill in the required amount of oil at the oiler (see Section 3.2).

5.9 Leybold Service

If a pump is returned to LEYBOLD, indicate whether the pump free of substances damaging to health or whether it is contaminated.

If it is contaminated also indicate the nature of the hazard. For this you must use a form which has been prepared by us which we will provide upon request.

A copy of this form is reproduced at the end of these Operating Instructions: "Declaration of Contamination of Vacuum Instruments and Components".

Please attach this form to the pump or enclose it with the pump.

This "Declaration of Contamination" is required to meet German Law and to protect our personnel.

LEYBOLD must return any pumps without a "Declaration of Contamination" to the sender's address.

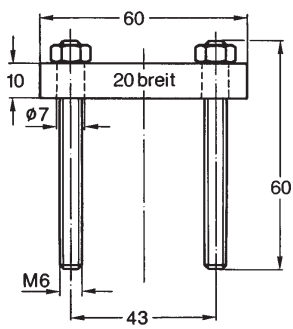

a – Pulling device for the coupling

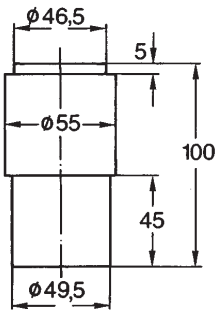

b– Shaft seal driver;
material: aluminium, brass or similar

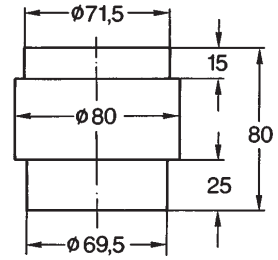

RUVAC WA/WAU 151/251/501

RUVAC WA/WAU 1001/2001

c – Two-armed puller

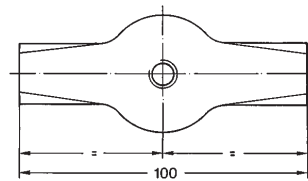
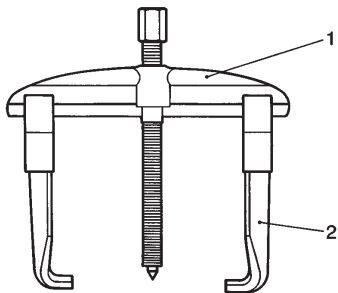

For item 1: Reworking of the cross bar

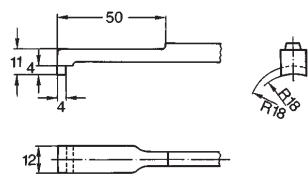

For item 2: Reworking of both hooks

Fig. 14 Special tools

6 Troubleshooting

| Fault | Possible cause | Remedy | Repair |
|---|--|--|---|
| Pump does not start. | Motor is connected incorrectly. Faulty pressure switch. Oil is too thick. Motor rotor is malfunctioning. Pump has seized up: damaged impellers, bearings or gearwheels. | Connect the motor correctly. Replace the pressure switch. Change the oil or warm the oil and the pump. Leybold Service Leybold Service | 3.3 3.3 5.2 – – |
| Pump gets too hot. | Ambient temperature is too high or cooling air supply is restricted. Pump is working in the wrong pressure range. Pressure differential is too great. Gas temperature is too high. Clearance between casing and impellers is too small due to: – contamination – distortion of pump. Excessive frictional resistance due to contaminated bearings and/or oil. Oil level is too high. Oil level is too low. Wrong oil has been used. Bearings are malfunctioning. Valve of pressure balance line does not open. | Install the pump at a suitable site or ensure enough cooling air. Check pressure values of vacuum system. Check pressure values of vacuum system. Check the vacuum system. Clean the pumping chamber. Ensure that the feet and connecting lines aren't placing a strain on the pump. Exchange oil. Drain some oil to reach the correct level. Add oil to reach the correct level. Drain oil and fill in correct lubricant. Leybold service Clean or repair the valve. | 3.1/5.4 – – – 5.6 3.1/3.4 5.2 5.2 5.2 – 5.7 |
| Power consumption of the motor is too high. | See fault "Pump gets too hot". Wrong mains voltage supply for the motor. Motor is malfunctioning. Oil is too thick | See fault "Pump gets too hot". Connect the motor to the correct voltage supply. Repair the motor or exchange it. Exchange the oil or warm up the oil and the pump. | – 1.3/3.3 – – |
| Pump is too loud. | Clearance between casing and impellers is too small due to : – contamination – distortion of the pump. Bearing or gearing is damaged. Impellers strike the casing. Rotor runs out of true. Centrifugal disc lubricator strikes gear lid or oil tube. Oil pump obstructed or malfunctioning. | Clean the pumping chamber. Ensure that the feet and connecting lines aren't placing a strain on the pump. Leybold service, switch off the pump immediately. Leybold service, switch off the pump immediately. Leybold service, switch off the pump immediately. Leybold service. Leybold service, switch off the pump immediately. | 5.6 3.1/3.4 – – – – – |
| Pump loses oil. | Oil leak is visible: Oil-drain plug is not tight. Oil-level glass is not tight. Gearbox cover is not tight. Oil puddle under the motor, leaky can No oil leak is visible: See fault "Oil in the pumping chamber". | Drain lubricant, firmly screw in the oil-drain plug with a new gasket, fill in the correct quantity. Leybold service. Replace the O-ring of the gearbox cover. Leybold service, switch off the pump immediately. See fault "Oil in the pumping chamber". | 5.2 – – – – |
| Oil level in the oiler drops. | Oil leak is visible: Outer shaft seal is malfunctioning. No oil leak is visible: Inner shaft seal is malfunctioning. | Exchange shaft seals. If the oil loss is only slight, the pump may still be operated for some time provided the lost oil is topped up regularly. Exchange shaft seals. Switch the pump off; oil flows into the bearing spaces of the pump thereby creating in the bearing spaces an unacceptably high oil level. | 5.8 5.8 |
| Oil turns dark. | Oil has broken down. Pump gets too hot. | Change the oil. See fault "Pump gets too hot"; after solving the problem, change the oil. | 5.2 – |
| Oil in the pumping chamber. | Oil level is too high. Oil leaks out of the system. Pump is not installed on a flat horizontal surface. Pump has an external leak. Pump has an internal leak. Impeller rings are malfunctioning. | Drain lubricant to reach the correct oil level. Check system. Install pump correctly. Check proper fit of oil-fill and oil-drain plugs, replace gaskets if necessary. Replace O-ring of the gearbox cover. Leybold service Leybold service | 5.2 – 3.1 3.2/5.2 – – – |
| Pumping speed of the pump is too low. | Dirt trap in the intake flange is clogged. Motor is connected incorrectly. Motor faulty. Pump or pump system has a leak. Clearance of impellers is too large. Bearing is malfunctioning. Valve of the pressure balance line does not close. Flow resistance in the intake or discharge line is too high | Clean the dirt trap. Connect the motor correctly. Leybold service Find and seal the leak. Leybold service Leybold service Clean or repair the valve. Use intake and discharge lines of sufficient diameter. | 5.5 3.3 – – – – 4.7 |

* for repair information, refer to the stated section in the Operating Instructions



EEC Manufacturer's Declaration

in the sense of the Directive on Machinery 89/392/EEG, Annex IIb

We – Leybold Vacuum GmbH – herewith declare that operation of the incomplete machine defined below, is not permissible until it has been determined that the machine into which this incomplete machine is to be installed, meets the regulations of the EEC Directive on Machinery.

Applied harmonised standards:

- EN 292 Part 1 and Part 2 Nov. 1991
- pr. EN 1012 Part 2 1993

Designation of the products: Roots pumps

Applied national standards and technical specifications:

Types: RUVAC WA without motor

- DIN 31 001 April 1983
- DIN ISO 1940 Dec. 1993

Cat. Nos.:

117 24; 117 34; 117 44

Cologne, Oct. 2, 1996

Plingen, Business Area Manager
Forevacuum pumps

Cologne, Oct. 2, 1996

Frings, Design Department Manager
Forevacuum pumps



Declaration of Conformity



We – LEYBOLD Vacuum GmbH – herewith declare that the products defined below meet the basic requirements regarding safety and health of the relevant EEC directives by design, type and versions which are brought into circulation by us.

In case of any product changes made without our approval, this declaration will be void.

The products conform to the following directives:

- EEC Directive on Machinery (89/392/EWG) and subsequent. 91/368/EWG
- EEC Directive on Low Voltages (73/23/EWG)
- EEC Directive on Elektromagnetic Compatibility (89/336/EWG)

Designation of the products: Roots pump

| | |
|-------|-----------|
| Types | RUVAC WA |
| | RUVAC WAU |

Applied harmonised standards:

- | | |
|----------------------------|-----------|
| • EN 292 Part 1 and Part 2 | Nov. 1991 |
| • pr. EN 1012 Part 2 | 1993 |
| • EN 60 204 | 1993 |

Cat. Nos.:

117 10; 117 11; 117 20; 117 21;
 117 30; 117 31; 117 40; 117 41;
 117 50; 117 51
 917 10; 917 11; 917 20;
 917 21; 917 30; 917 31;
 917 40; 917 41; 917 50;
 917 51;
 118 31; 118 41; 118 51

Applied national standards and technical specifications:

- | | |
|----------------|------------|
| • DIN 31 001 | April 1983 |
| • DIN ISO 1940 | Dec. 1993 |

Cologne, Oct. 2, 1996



 Plingen, Business Area Manager
 Forevacuum pumps

Cologne, Oct. 2, 1996



 Frings, Design Department Manager
 Forevacuum pumps

LEYBOLD VAKUUM GmbH

Bonner Straße 498 (Bayenthal)

D-50968 Köln

Telefon: (0221) 347-0

Telefax: (0221) 347-1250

LK.1.80.637.45 OF/RSP 10.96

Printed in Germany on chlorine-free bleached paper