



SD-876E

## DRY VACUUM PUMP

APPLICABLE TYPE

NeoDry36C

## INSTRUCTION MANUAL

Date	Record
'09.06	Prepared

**KASHIYAMA IND., LTD.**

## HANDLING OF MANUAL

This instruction manual describes installation, operation, and maintenance about the NeoDry Series Dry Vacuum Pump.

Be sure to read this instruction manual to correctly operation before installing and operating it. In particular, take care about the precautions for safety to following warning words.

### DANGER

This indicates the existence of imminent hazard, which if the equipment is operated without respect to its contents, will result in death or a serious injury of the operator.

### WARNING

This indicates the existence of potential hazard, which if the equipment is operated without respect to its contents, will result in death or a serious injury of the operator.

### CAUTION

This indicates the existence of potential hazard, which if the equipment is operated without respect to its contents, may result in slight injury or less serious injury of the operator.

### CONFIRMATION

This indicates the existence of possibility, which if the equipment is operated without respect to its contents, may result in equipment damage.

#### <STORAGE OF THIS INSTRUCTION MANUAL>

This instruction manual describes important matters related to pump operation. Keep the manual in an easy-to-see place so that it may be available whenever required.

## WARRANTY OF THE DRY PUMP

Any failure attributable to our responsibility which is due to a defect of design, material, manufacturing, and occurs within two years after acceptance shall be repaired or replaced free of charge.

This warranty shall be applicable only to the case where the equipment has been correctly operated in accordance with this instruction manual and other instructions. Additionally warranty period by different usage is set forth hereunder. Any defectives or damages that fall into the case stipulated below as "Exemption of the warranty" shall be out of warranty.

### **Warranty period by different usage.**

One (1) year warranty: Exhaust of mixed particle amount of water and solvent.  
(To be discussed separately about it's kind and amount)

Two (2) years warranty: Air / N2 / clean gas exhaust.

### **Exemption of the warranty.**

- \* Failure due to improper handling, operation or storage.
- \* Failure caused by the usage of special gas like acid, alkaline, corrosive gas, or the usage possibly contains solid or may cause solidification and condensation.
- \* Failure due to negligence of necessary maintenance.
- \* Failure due to use of maintenance/replacement parts other than those made by Kashiyama.
- \* Failure due to repair and modification by and party other than Kashiyama and Kashiyama's approved dealers.
- \* Failure due to fire, flood, earthquake, lightning and other force majeure.

This "Warranty" limitedly warrants to the repair and replacement of the affected portion of the product, and does not warrant to the defect and damage collaterally occurs therewith. Also This "Warranty" shall not be applicable to wearing and maintenance parts.

In case any failure or fault occurs, please inform to our business office.

## APPLICATION OF THE VACUUM PUMP

\* This vacuum pump is intended to get a vacuum source for vacuum exhaust, maintenance of vacuum condition, and a clean usage as a vacuum source for general industry.

However, the above is not applicable to the case where using this vacuum pump has been judged to be usable for a use other than these by a previous arrangement with the user before purchase.

\* When the use is going to change the process for using this vacuum pump or divert this pump to another use, please consult our business office or Shinshu Plant, Technical Section. It may be necessary to change the specifications of the pump and peripheral units.

\* Using this vacuum pump to the process where radiation exist is prohibited.



**DANGER**

This pump is not an airtight structure.

Don't use it to exhaust the combustible gas or the dangerous fumes for the human body, etc.

## Contents

1.	ITEMS RELATED TO SAFETY	
1.1	Safety	----- 1
1.2	Types of Warning Label	----- 3
1.3	Warning Label Sticking Positions	----- 3
2.	PRODUCT CONFIRMATION	----- 4
3.	PRODUCT OVERVIEW	
3.1	Pump Body	----- 5
3.2	Coupling	----- 5
3.3	Motor	----- 5
3.4	Product Specifications	----- 6
3.5	External View	----- 7
3.6	Pumping Performance	----- 8
4.	INSTALLATION OF THE PUMP	
4.1	Installation	----- 9
4.2	Piping	----- 11
4.3	Electric Wiring	----- 12
5.	OPERATION PANEL	----- 15
6.	OPERATION AND STOP	
6.1	Preparations for Operation	----- 16
6.2	Operation and stop	----- 16
6.4	About the gas ballast mechanism	----- 19
7.	MAINTENANCE	
7.1	Maintenance Method	----- 20
7.2	Maintenance Standard	----- 21
7.3	Removal of the Pump	----- 22
8.	TROUBLESHOOTING	
8.1	Primary Trouble	----- 23
8.2	Pump Malfunction	----- 24
9.	SCRAPPING METHOD	----- 25
10.	PRECAUTIONS ON RETURN OF PRODUCT	
10.1	Special Noteworthy Matter	----- 25
10.2	Returning Procedure	----- 25
	< Notice >	
	Return Notice Sheet	

## 1. ITEMS RELATED TO SAFETY

### 1.1 Safety

This instruction manual describes the following items related to safety.



#### **DANGER**

Don't connect the power cable to the power socket before completion of electric wiring work; otherwise an electric shock may be caused.

Disconnect power connector before starting maintenance work; otherwise an electric shock may be caused.



#### **WARNING**

When lifting the pump, secure safety by a worker qualified for operating the forklift truck or crane.

Don't stand below the lifted pump in any case; otherwise injury may be caused by falling.

Because the temperatures of the suction and exhaust pipes of the pump become high, arrange them so that they may not come in contact with the human body and combustible materials.

Wiring work must be done by qualified workers.

Be sure to perform grounding, otherwise an electric shock may be caused by electric leakage.

The pump is at high temperature for a while after it is stopped. Don't touch the human body or bring flammable materials close to the pump; otherwise a burn may be caused.

#### **CAUTION**

Don't get on the pump or put a thing on it; otherwise falling or turnover may be caused.

Adopt high corrosion-resistant materials for pipes and parts used on both suction port and exhaust port sides.

## CONFIRMATION

Don't pile packed pumps and don't lay each pump on its side in any case; otherwise the damage may be caused to the pumps.

Keep space, 100mm or more at front and rear side, 50mm or more at lateral side, to secure good ventilation for cooling. Bad ventilation can cause pump overheat which results in unpredicted pump failure.

For Input signals (Pin No. 1-9, 2-10, 3-11, 4-12), apply a voltage of 24V DC on the pump controller side. Don't apply a voltage on the equipment side, otherwise the controller may go wrong.

The output signal (pin No. 5-13) is no-voltage relay contact outputs. Apply a voltage of 24 V DC, 0.1A or less on the equipment side.

When condensable gas such as water vapor is pumped, please keep it running for about 1 hour opening the inlet port. There is a possibility of pump failure arising from corrosion or other factors when condensed moisture, etc. remains inside the pump.

When operating under "Direct power input", pump stops running if STOP/RESET button is pushed. To re-start the pump, shut off the power first—LED display goes off—then turn on the power supply. The pump immediately re-starts.

As frequent ON and OFF can shorten inverter's life, change the running mode to "Operation through external signal", shown in article 6-2-3, if such handling is necessary.

When the pump is in low temp, the effect of gas ballast is poor. Warm up the pump enough, if possible more than an hour, when it pumps out water vapor or condensable gas.

In the status that "PU/EXT Selection switch" in the I/O connector (CN2) is open— means Pin.3-11 is open circuit—, external signal mode is not available. In this case, handling by operation-panel is required.

When the pump is in low temp. The effect of gas ballast is poor. Warm up the pump enough, if possible more than an hour, when it pumps out water vapor or condensable gas.

The condensable gas, which isn't condensed in the pump, might be condensed in the exhaust piping. Take care of the condensate not to move back into the pump.

Store the pump with its inside dry, as trouble may arise on restart, if condensable gas like water vapor is left inside.

When the pump is stopped in the gas ballast valve state of "Open", the gas is introduced from the gas ballast valve and the vacuum of the pump cannot be maintained. Please install the shut-off valve between the pump and exhaust system, and shut before the pump stops when the vacuum maintenance of the vacuum system is necessary when the pump stops.

At the trigger/alarm level (At the warning message departure report), there is a possibility that a sudden stop or breakdown occurs if driving is continued as it is though the pump doesn't stop.

### <Notice>

When you return the pump for repair or overhaul, remove the remaining reactant gas completely by using N2 gas, and fill in the form of Return Notice Sheet attached to the final page of this document before you send the pump back to us.

The items related to safety are also described in the relevant items in this document. Please be sure to read the whole instruction manual.

### 3. PRODUCT OVERVIEW

Pumps basically consist of a pumping mechanism, a motor that are mounted on the base.

#### 3.1 Pump Body

- \* A pair of hybrid roots rotors synchronously rotates, keeping a given clearance, and transfers the gas from inlet port to exhaust port.
- \* Bearings and gears are installed and lubricated with oil.
- \* The other side of the gear runs to an atmospheric side through the seal.  
(This pump is not an airtight structure.)
- \* This series adopts induction motor.
- \* They are heated up by the compressed gas, the friction at the bearing and at the seals makes pump temperature high, under which the pump is cooled with cooling fan.
- \* To prevent condensation in the pump when condensed gas is pumped, the gas ballast mechanism is built in.  
(The gas ballast mechanism is an option.)
- \* To decrease the exhaust noise, the silencer is built in.

#### 3.2 Electrical equipment

- \* The pump package has built-in circuit protector, noise filter, and inverter.
- \* Pump differs, by the specification of power supply, from others in these components and power connector. Choose pump that matches to your power supply.  
(See Product Specification for power supply and type of pump.)



### 3.4 Product Specifications

Specification Table

Item \ Model		NeoDry36C		
		NeoDry36C-1 (Single Phase 100V)	NeoDry36C-2 (Single Phase 200V)	NeoDry36C-3 (Three Phase 200V)
Max. Pumping Speed [50/60 Hz]		600 L/min		
Ultimate Pressure (Note 1)	Gas ballast : OFF	1.0 Pa		
	Gas ballast : ON	2.0 Pa		
Max. Inlet Pressure		Atmospheric pressure		
Outlet Back Pressure		3 kPa G or less		
Max. water vapor pumping rate (Note 2)		350 g h <sup>-1</sup>		
Motor Rated Power		0.75 kW		
Rated Current (Primary side)		12.6 A	7.5 A	3.2 A
Flange Size	Inlet	NW40		
	Outlet	NW25		
Publication Oil		0.24 litter (Synthetic oil)		
Weight		Approx. 58 kg		
Size		298W x 475L x 275H		
Atmosphere temperature		15 to 30 deg. C		
Others		This pump dose not have perfect gas-tight structure.		
<b>Utility Requirements</b>				
Power Supply	Voltage [50/60 Hz]	Single phase		Three phase
		100-115 V	200-240 V	200-240 V
	Input voltage fluctuation must be <+/- 10% range (Note 3)			
	Capacity	1.5 kVA		

Note 1) The gas ballast mechanism is an option.

Note 2) It is an amount of the maximum processing when the gas ballast valve (option) opens completely.

Note 3) This dose not denote an allowable value of steady voltage, but not an allowable value of variation.

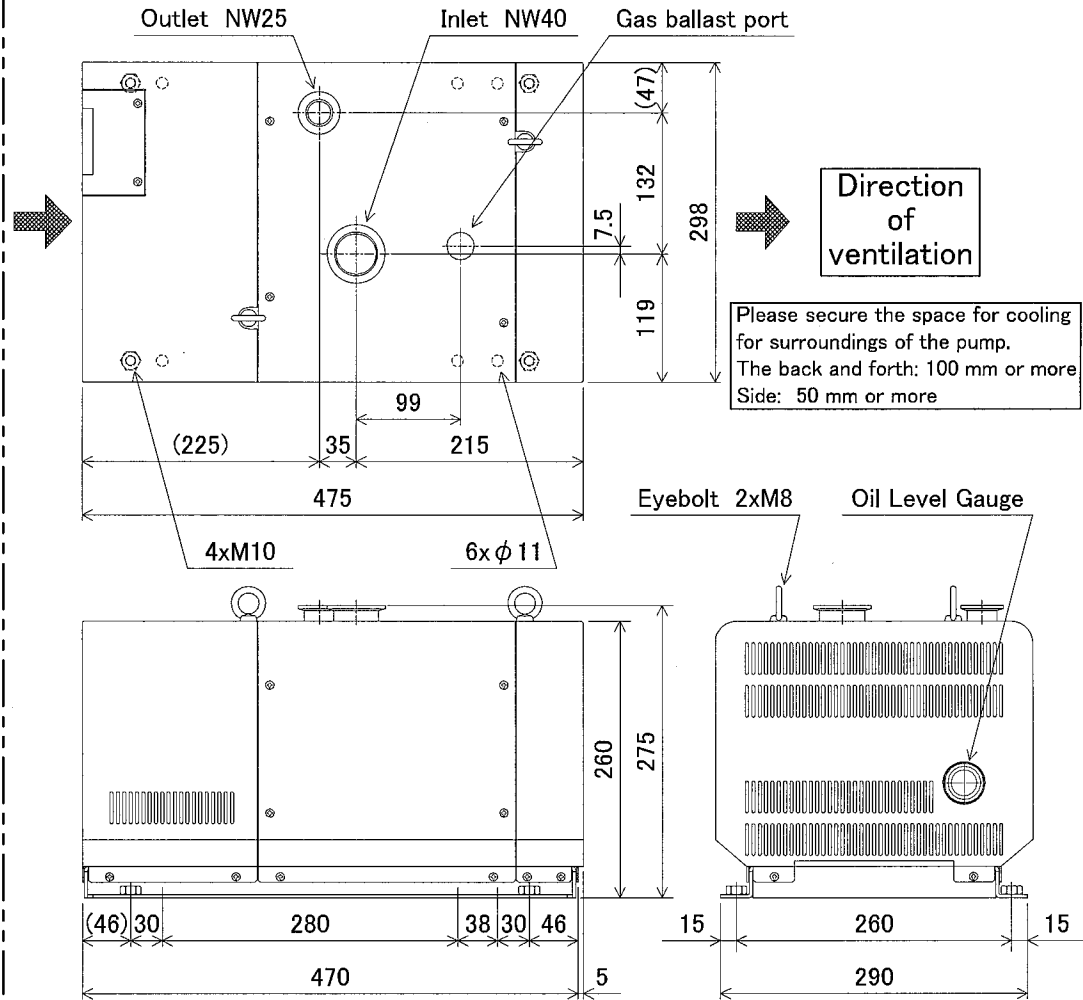
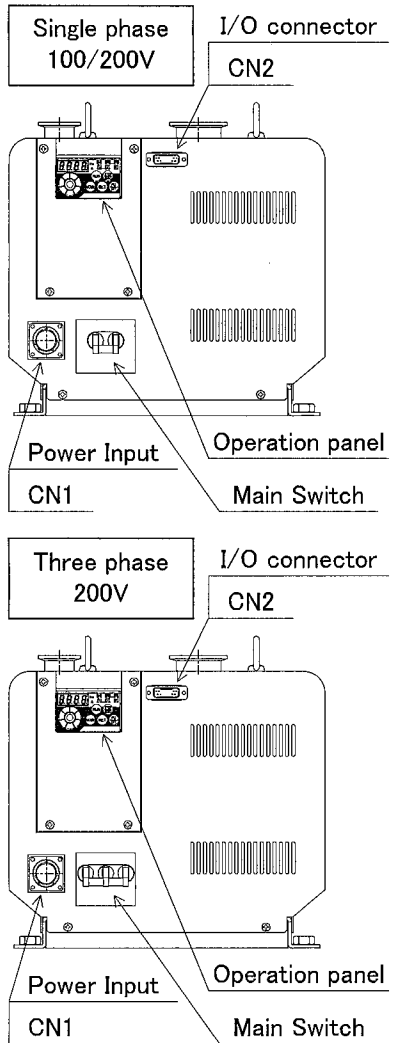

3.5 External View

### 3.6 Pumping Performance

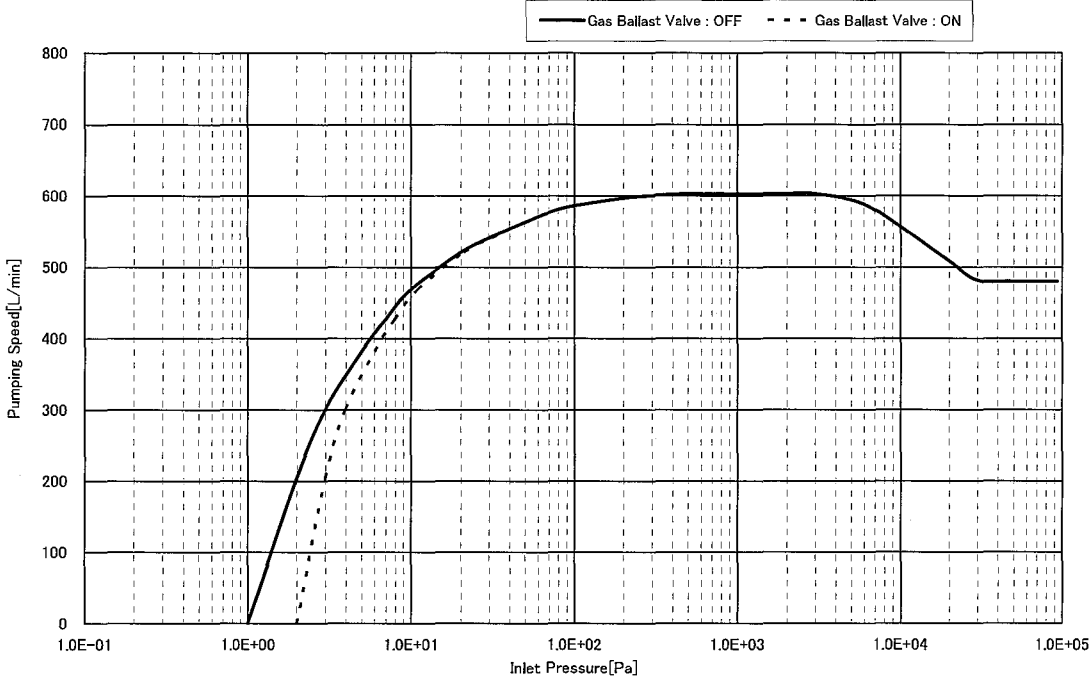

Note) The gas ballast mechanism is an option.

## 4. INSTALLATION OF THE PUMP

The pumping performance of the dry vacuum pump is affected by the opening diameter and length of the suction / exhaust pipe and the performance of the installed peripheral units. Moreover, when corrosive gas is pumped, proper maintenance is required for each use to operate the pump normally for a long period. When the pump is installed, valves and pipes are recommended to be installed beforehand to secure higher maintenance efficiency. Adopt pipes and sealing parts in consideration of corrosion resistance.

### 4.1 Installation

#### 4.1.1 Installation

#### **WARNING**

When lifting the pump, secure safety by a worker qualified for operating the forklift truck or crane.

Don't stand below the lifted pump in any case; otherwise injury may be caused by falling.

Use a proper wire and a proper crane for lifting the pump, which are suitable for the weight of the pump.

When lifting the pump, make the lifting angle of the wires equal so that the load may not be one-sided. (Fig. 4.1)

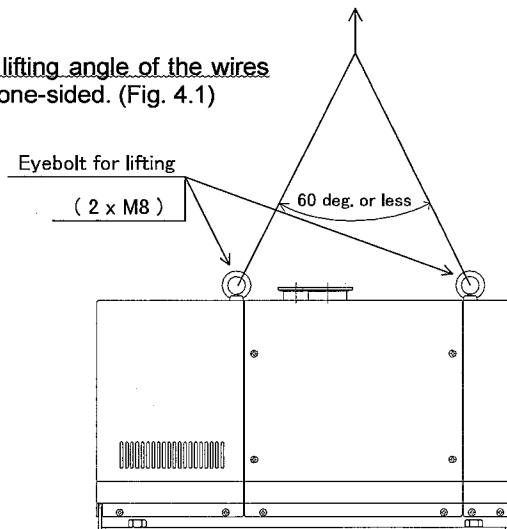

Fig.4.1 How to Lift the Pump

#### **CAUTION**

Don't get on the pump or put a thing on it; otherwise falling or turnover may be caused.

#### **CONFIRMATION**

Keep space, 100mm or more at front and rear side, 50mm or more at lateral side, to secure good ventilation for cooling. Bad ventilation can cause pump overheat which results in unpredicted pump failure.

- \* Install the pump indoors.
- \* Install the pump on a solid and level surface of the floor.
- \* Allow a proper space around the pump so that the pump may be installed and maintained smoothly.
- \* Be careful not to make the temperature exceed 30 deg. C and not to make the humidity exceed 80% around the pump while it is operating, especially in closed place, because that may cause dew condensation inside the pump.
- \* Keep space, 100mm or more at front and rear side, 50mm or more at lateral side, to secure good ventilation for cooling.
- \* Set the pump up in the place of above sea level 1000m or less.

\* Please use by "Pollution degree 2".

Avoid installing the pump in the following places:

- a) Outdoors, a place that may be splashed with water, and a place of extremely high humidity. (A place of 80% or higher humidity is not proper.)
- b) A place where a toxic gas such as acid and alkali gases exists.
- c) A place where an explosive or combustible gas exists.
- d) A dusty place.

\*Please do fixation and the horizontal putting out of the pump with the base. (Fig. 4.2, 3)  
(If the pump is with casters and adjusters, its way of anchoring pump differs from others.  
Contact to our sales office for how to anchor the pump.)

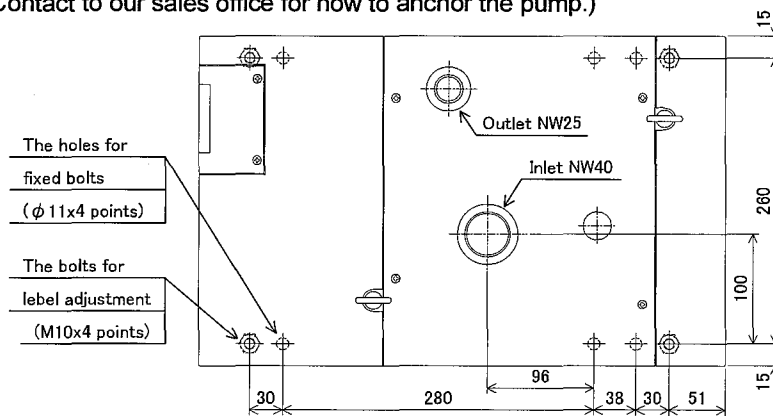

Fig.4.2 Pump fixation position

- \* The pump is a heavy material (Approx. 58 kg). To facilitate the maintenance work, install the pump on the floor.
- \* When moving pump on the uneven place, please put the pump on the carriage.
- \* Removing the lifting eyebolts is possible after installing the pump. Please keep the removed eyebolts carefully.

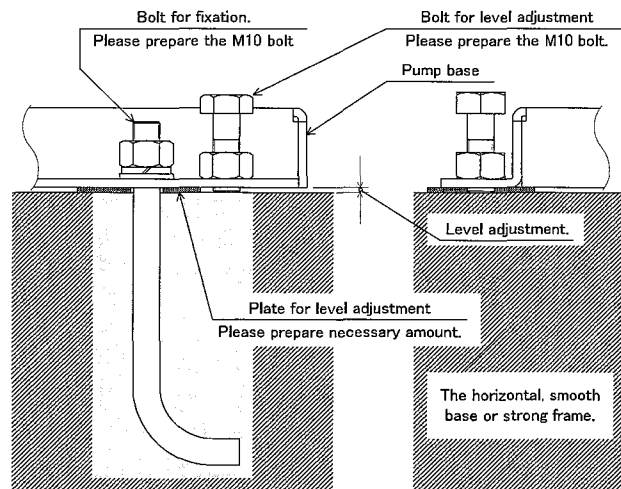

Fig.4.3 How to fix the pump

## 4.2 Piping

### 4.2.1 Vacuum and exhaust piping

Connect a vacuum pipe and an exhaust pipe to the suction port and the exhaust port, respectively. The suction port of the dry pump is an NW40 quick flange, while the exhaust port of this pump is an NW25 quick flange. Perform piping or make connections to different parts by using these flanges.

### **WARNING**

Because the temperatures of the suction and exhaust pipes of the pump become high, arrange them so that they may not come in contact with the human body and combustible materials.

### **CAUTION**

Adopt high corrosion-resistant materials for pipes and parts used on both suction port and exhaust port sides.

- \* Use clean pipes without any foreign material for piping.
- \* Don't install a heavy material directly at the suction port and the exhaust port; otherwise a leak or damage will be caused to the connecting portions.
- \* It is recommended to use a stainless flexible joint between the pump and a pipe.
- \* Take care adhering of either any dust or foreign material to the flange seal surface. And take care not to put the scar on the flange face.
- \* To keep the exhausted system in a vacuum condition, install a vacuum shut-off valve between the pump and the exhausted system.
- \* If there is a possibility that dust may be absorbed, install a proper scale trap at the first stage of the pump.
- \* Take it into consideration to allow enough conductance for piping and exhaust gas processing facilities so that the pressure on the exhaust port side (back pressure) of this pump may be 3 kPa or less.

### 4.3 Electric Wiring

The earth leakage breaker is not installed on this pump.  
Use adequate the earth leakage breaker which corresponds to the spec below, if necessary.

Table 4.1 Power supply and capacity of breaker

		NeoDry36C		
		Single phase		3 phase
Type		NeoDry36C-1	NeoDry36C-2	NeoDry36C-3
Power supply [50/60 Hz]		100-115 V	200-240 V	200-240 V
Earth leakage breaker	Rated Voltage	125 V or more	250 V	250 V
	Rated Current	15 A	15 A	10 A
	Rated Sensitivity Current	30 mA		

\*) The pump model is different depending on the power supply specification.



### **DANGER**

Don't connect the power cable to the power socket before completion of electric wiring work; otherwise an electric shock may be caused.



### **WARNING**

Wiring work must be done by qualified workers.

#### 4.3.1 Power wiring (Connector symbol : CN1, power supply)



### **WARNING**

Be sure to perform grounding, otherwise an electric shock may be caused by electric leakage.

Use the wiring materials that correspond to the pump power.

Table 4.2 Wiring material

Type	NeoDry36C-1,2	NeoDry36C-3
Applicable wire size	AWG#14 (2.0 mm <sup>2</sup> )	AWG#16 (1.25 mm <sup>2</sup> )
Number of wicks	3	4

A. How to connect wires; Single phase 100V type. [NeoDry36C-1]

For pin connections of the power connector, refer to Fig.4.4, Table 4.3, and Table 4.4.

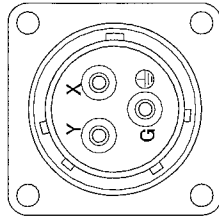

Table 4.3 CN1 Receptacle Pin Assign

Pin No.	Phase
X	L : Load
Y	N : Neutral (Ground side)
G	Grounding

Fig.4.4 CN1 Pump-side Receptacle

Table 4.4 CN1 Receptacle Specification

Receptacle model	NET-243RM
Connector maker	Nanaboishi Electric Mfg. Co.,Ltd.
Applicable plug (Note)	NET-243PF
Applicable wire size	AWG #14 (2.0mm <sup>2</sup> )

Note) Applicable plug is standard accessory

B. How to connect wires ; Single phase 100V type. [NeoDry36C-2,3]

For pin connections of the power connector, refer to Fig.4.5, Table 4.5, and Table 4.6.

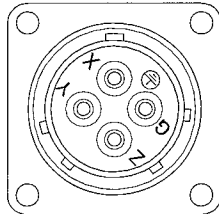

Table 4.5 CN1 Receptacle Pin Assign

Pin No.	Phase	
	Single phase 200V	Three phase 200V
	NeoDry36C-2	NeoDry36C-3
X	L : Load	R
Y	N : Neutral (Ground side)	S
Z	(Not connected)	T
G	Grounding	

Fig.4.5 CN1 Pump-side Receptacle

Table 4.6 CN1 Receptacle Specification

Receptacle model	NET-244RM	
Connector maker	Nanaboishi Electric Mfg. Co.,Ltd.	
Applicable plug (Note)	NET-244PF	
Applicable wire size	NeoDry36C-2	AWG #14 (2.0mm <sup>2</sup> )
	NeoDry36C-3	AWG #16 (1.25mm <sup>2</sup> )

Note) Applicable plug is standard accessory



4-3-2. Control wiring (Connector symbol : CN2, remote control input/output)

Please install the driving connector in the I/O connector (CN2) when it will operate under "Direct power input".

To perform remote operation or monitoring, perform wiring to CN2.  
For pin connections, refer to Fig.4.6, Fig.4.7 and Table4.7.

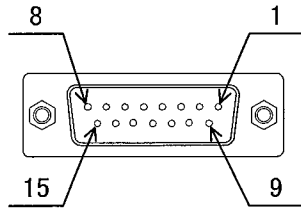

Fig.4.6 CN2 Pump-side Receptacle

Table 4.7 CN2 Receptacle Specification

D-sub model	DA-15SF-N
Fixed screw	M2.6
Connector maker	Japan Aviation Electronics Ind., Ltd.
Applicable plug (Note)	DA-15PF-N
Clamp hood (Note)	DA-C8-J10-F1-1
Applicable wire size	AWG #24-20 (0.2-0.5mm <sup>2</sup> )

Note) Applicable plug and clamp hood are standard accessories

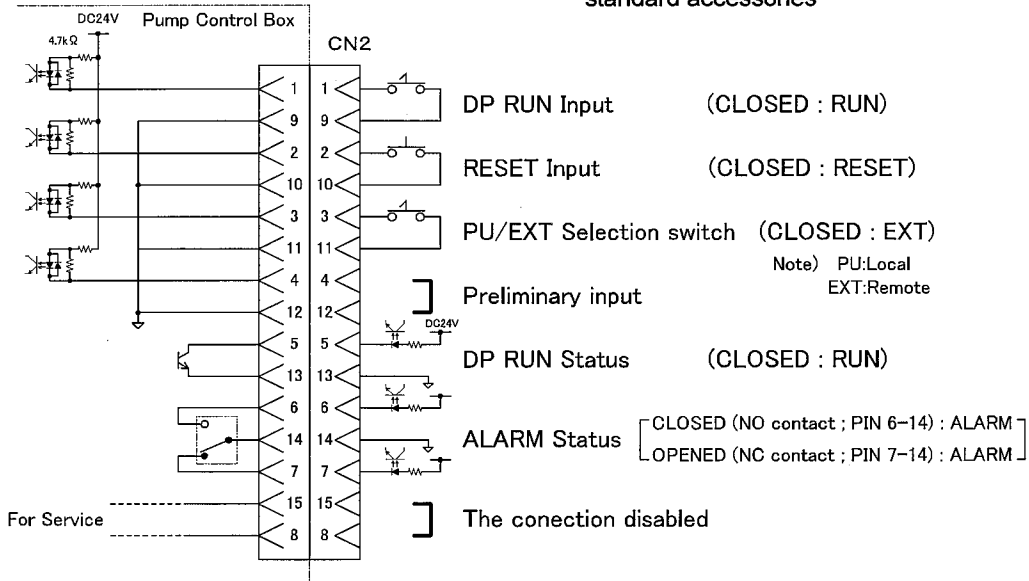

Fig.4.7 CN2 D-sub Connector Pin connections

## CONFIRMATION

For Input signals (Pin No. 1-9, 2-10, 3-11, 4-12), apply a voltage of 24V DC on the pump controller side. Don't apply a voltage on the equipment side; otherwise the controller may go wrong.

The output signal (pin No. 5-13) is no-voltage relay contact outputs. Apply a voltage of 24 V DC, 0.1A or less on the equipment side.

The output signal (pin No. 6, 7-14) is change-over (CO) contact.  
The contact capacity is AC230V/0.3A and DC30V/0.3A.

Please make the RESET Input signal (pin No. 2-10) "Closed" for 0.1 seconds or more.

## 5. OPERATION PANEL

There are four different modes to run and stop the pump, "Direct power input", "Operation by operation-panel", "Operation by external signal" and "Operation by the handheld controller". If "Direct power input" is selected, set driving connector, that is standard accessory, onto "I/O connector (CN2)".

Running status can be checked by LED display on operation-panel.

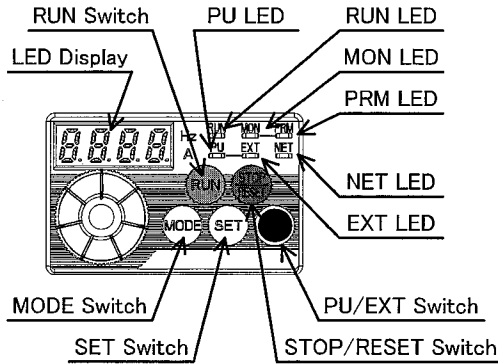

Fig. 5.1 Operation panel

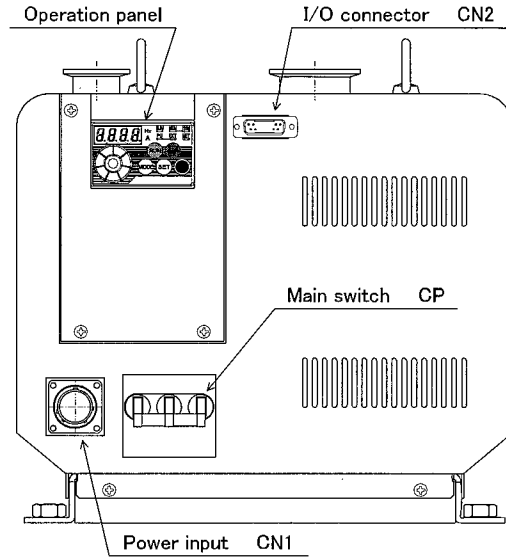

Fig. 5.2 Pump operation side

Explanation of operation panel.

LED indicator	Operational duration, rpm, Inverter current at secondary side.
RUN LED	This lights when running.
MON LED	This lights when power is supplied.
PRM LED	*This does not light under normal circumstances.
PU LED	This lights when operational panel is available.
EXT LED	This lights when external signal is available.
NET LED	*This does not light under normal circumstances.
RUN Switch	When PU is ON, the pump starts to run after this button is pushed (ON).
STOP/RESET Switch	The pump stop or is reset when this button is pushed (ON).
MODE Switch	*Not available.
SET Switch	Changes the indication of LED.
PU/EXT Switch	*Not available.

\*LED display changes its indication as follow when SET is pushed during operation.  
 Cumulative operational hours → Inverter frequency → Output current → Cumulative operational hours  
 (LED display shows cumulative operational hours when power is initially supplied)

\*[x.xxx] appears on LED display as cumulative operational hours; however it represents [x.xxx times 1,000hours]. For example: 10.00 stands for 10,000 hours.

\*Cumulative operational hours returns to 0 after it reaches to upper limit of 65,530 hours.

## 6. OPERATION AND STOP

### 6.1 Preparations for Operation

- 1) Check if electric wiring is correctly and securely performed.
- 2) Check if the suction pipe and the exhaust pipe are securely connected. When a valve is installed on the exhaust side, open the valve securely before starting the pump.
- 3) Make sure good ventilation for the pump is secured.
- 4) Please confirm the gas ballast mechanism is shut (The valve is closed).  
(The gas ballast mechanism is an option.)

### 6.2 Operation

#### WARNING

The pump is at high temperature for a while after it is stopped. Don't touch the human body or bring flammable materials close to the pump; otherwise a burn may be caused.

#### CONFIRMATION

When condensable gas such as water vapor is pumped, please keep it running for about 1 hour opening the inlet port. There is a possibility of pump failure arising from corrosion or other factors when condensed moisture, etc. remains inside the pump.

- \* Close the cut-off valve on the suction port side of the pump when needed.  
(To keep the vacuum system in vacuum, it is necessary to install shut-off valve between the system and the pump. Close this valve before the pump stops.)
- \* When condensable gas such as water vapor has been pumped, please keeps the pump running opening the inlet port for about one hour after pump operation.  
Corrosion in the pump can be prevented by removing the residual with dry air.  
As the pumped gas quantity is larger, perform the dry air pumping for a longer time.
- \* If there is an open/close valve on the exhaust port side of the pump, close this valve.

#### 6-2-1. Direct power input.

<Please install the driving connector in the I/O connector (CN2).>

#### A. Driving by primary side power supply ON/OFF

- 1) Switch on the MAIN POWER switch (CP) on the pump.
- 2) Supply power to the pump. At the time, the pump will be started.  
(The RUN LED, MON LED and EXT LED on the operation panel will come on.)
- 3) Make sure that abnormality is not found after the pump starts.
- 4) When the power supply is turned off, the pump will be stopped.  
(The RUN LED, MON LED and EXT LED on the operation panel will go out.)



## B. Driving by MAIN POWER switch ON/OFF

- 1) Supply power to the pump.
- 2) Switch on the MAIN POWER switch (CP) on the pump. At the time, the pump will be started. (The RUN LED, MON LED and EXT LED on the operation panel will come on.)
- 3) Make sure that abnormality is not found after the pump starts.
- 4) When the MAIN POWER switch (CP) is turned off, the pump will be stopped. (The RUN LED, MON LED and EXT LED on the operation panel will go out.)

## CONFIRMATION

When operating under "Direct power input", pump stops running if STOP/RESET button is pushed. To re-start the pump, shut off the power first—LED display goes off—then turn on the power supply. The pump immediately re-starts.

As frequent ON and OFF can shorten inverter's life, change the running mode to "Operation through external signal", shown in clause 6-2-3, if such handling is necessary.

### 6-2-2. Operation by operation-panel.

< Please confirm the driving connector has not placed to I/O connector (CN2) >

- 1) Supply power to the pump.  
Switch on the MAIN POWER switch (CP) on the pump.  
(The MON LED and PU LED on the operation panel will come on.)
- 2) Switch on the RUN switch on the operation panel. At the time the pump will be started.  
(The RUN LED, MON LED and PU LED on the operation panel will come on.)
- 3) Make sure that abnormality is not found after the pump starts.
- 4) Push the STOP/RESET switch on the operation panel, the pump will be stopped.  
(The RUN LED on the operation panel will go out.)

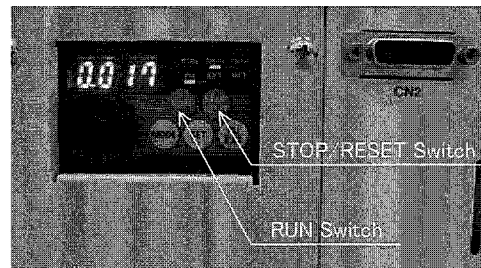

### 6-2-3. Operation by external signal

<Please do wiring for the control to I/O connector (CN2) >

(Please refer to the chart of clause 4-3-2 Control wiring (page 14) for details of wiring for the control.)

- 1) Supply power to the pump.  
Switch on the MAIN POWER switch (CP) on the pump.  
(The MON LED and PU LED on the operation panel will come on.)
- 2) Input the PU/EXT Selection signal from the I/O connector (CN2). (Closing Pin.3-11)  
(The MON LED and EXT LED on the operation panel will come on and PU LED will go out)
- 3) Input the DP RUN Input signal from the I/O connector (CN2). (Closing Pin 1-9)

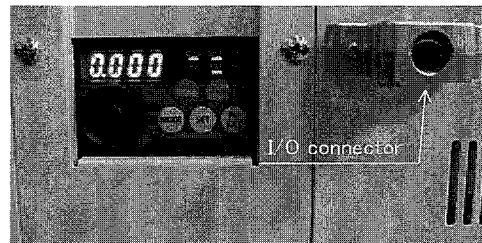

- 4) The pump will be started and RUN LED, MON LED and EXT LED on the operation panel will come on.  
At the time, DP RUN Status signal will be put into a make state. (Closing Pin 13-6)
- 5) Make sure that abnormality is not found after the pump starts.
- 6) Put the DP RUN Input signal from the I/O connector (CN2) into an open state.  
(Opening Pin 1-9)  
The pump will be stopped and the RUN LED on the operation panel will go out.  
At the time, DP RUN Status signal will be put into an open state. (Opening Pin 13-6)

## CONFIRMATION

In the status that "PU/EXT Selection switch" in the I/O connector (CN2) is open— means Pin.3-11 is open circuit—, external signal mode is not available. In this case, handling by operation-panel is required.

### 6-2-4. Operation by the handheld controller

Note) The handheld controller is an option.

<Please connect the handheld controller attachment cable with the I/O connector (CN2) >

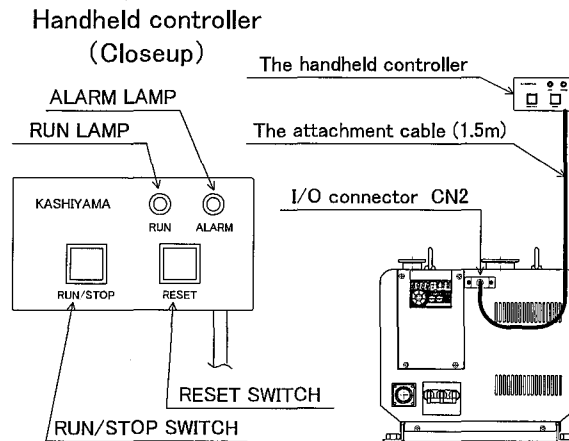

- 1) Supply power to the pump.  
Switch on the MAIN POWER switch (CP) on the pump.  
(The MON LED and EXT LED on the operation panel will come on.)
- 2) Push the RUN/STOP switch on the handheld controller.  
The pump will be started and the RUN LAMP on the handheld controller will come on.  
(The RUN LED, MON LED and EXT LED on the operation panel will come on.)
- 3) Make sure that abnormality is not found after the pump starts.
- 4) Push the RUN/STOP switch on the handheld controller.  
The pump operation will stop and the RUN LAMP on the handheld controller will go out.

## CONFIRMATION

Please do not detach the handheld controller while driving the pump. The pump stops when the handheld controller is removed in the pumping operation.

## 6.4 About the Gas ballast mechanism

Note) The gas ballast mechanism is an option.

### CONFIRMATION

When the pump is in low temp, the effect of gas ballast is poor. Warm up the pump enough, if possible more than an hour, when it pumps out water vapor or condensable gas.

The condensable gas, which isn't condensed in the pump, might be condensed in the exhaust piping. Take care of the condensate not to move back into the pump.

Store the pump with its inside dry, as trouble may arise on restart, if condensable gas like water vapor is left inside.

When the pump is stopped in the gas ballast valve state of "Open", the gas is introduced from the gas ballast valve and the vacuum of the pump cannot be maintained. Please install the shut-off valve between the pump and exhaust system, and shut before the pump stops when the vacuum maintenance of the vacuum system is necessary when the pump stops.

\*Condensed gas such as water vapor can be prevented from being condensed in the pump by making the gas ballast valve "Open" when condensed gas is introduced.

\*The gas ballast has different effect, depending on the pump operating temperature, the kind of condensable gas and its amount.

\*In order to remove condensable gas from inside the pump, it is effective to keep the pump running about two hours with the valve on after pumping out condensable gas like water vapor. When large amount of condensable gas is pumped, run the pump around one hour with the inlet open, then close the inlet and run the pump around two hours the gas ballast valve on.

\*Please use with gas ballast valve off, when you do not pump condensable gas.

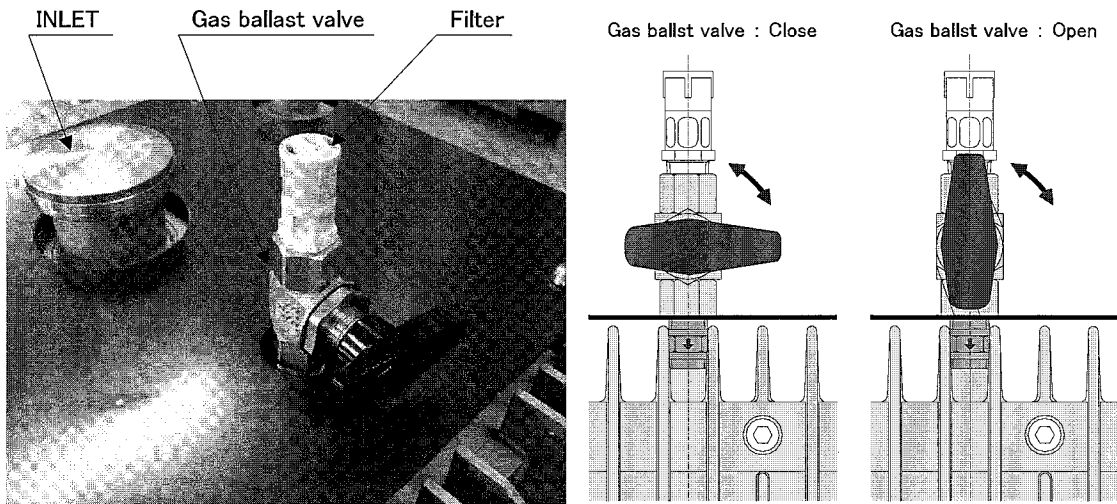

Gas ballast valve mechanism

## 7. MAINTENANCE

### 7.1 Maintenance Method

In order to the safe operation and maintain its performance for a long time, take the following points into consideration.

- a) Operate the pump within the range described in the catalog and the instruction manual.
- b) Perform inspection as specified in the maintenance standard.
- c) For disassembly and inspection or overhaul, return your product to Kashiya or a dealer approved by us.  
Please consult with our business office beforehand.

Recommended cycles of overhaul by different usage are as below.

Recommended overhaul cycle	Usage
Every 1-2 years (with gas ballast)	Moist, Solvent mixture (to be discussed about its kind and amount, if exhaust of solvent)
Every 3 years	Air, N <sub>2</sub> , clean gas exhaust.

Overhaul cycle may change in response to the condition of the usage.

When the gas to be pumped is very reactive or corrosive, it may be necessary to have overhauled more than once year.

<Notice>

When you return the pump for repair or overhaul, remove the remaining reactant gas completely by using N<sub>2</sub> gas, and fill in the form of Return Notice Sheet attached to the final page of this document before you send the pump back to us.

We may not be able to accept an overhaul of pumps that used arsenic gas or phosphorous gas. Please consult with our business office beforehand.

- d) In case of products with special specifications, the maintenance period and method may be different. Please ask us for information.
- e) When the pump need to be stopped for a long time for reasons of holidays or the like, stop the pump and perform N<sub>2</sub> purging completely. Then, seal the suction port and exhaust port of the pump with blank flanges at once.

About customer service, please ask your nearest business office for information.

## 8. TROUBLESHOOTING

### **DANGER**

Don't connect the power cable to the power socket before completion of electric wiring work; otherwise an electric shock may be caused.

Disconnect power connector before starting maintenance work; otherwise an electric shock may be caused.

### **WARNING**

Wiring work must be done by qualified workers.

The pump is at high temperature for a while after it is stopped. Don't touch the human body or bring flammable materials close to the pump; otherwise a burn may be caused.

### 8.1 Primary trouble

Symptoms	Probable Causes	Corrective measures
PUMP does not start	The power isn't supplied to the pump.	Check if the power is supplied to the pump.
	Pump error	Pump replacement or overhaul is needed.
	The driving connector doesn't install on the I/O connector (CN2)	When "Direct power input" is selected, set driving connector onto "I/O connector (CN2)".
Abnormal noise. Intense vibration	Some objects on the outside cover.	Take the objects away.
	Vises to fix the outside cover are loosened.	Tighten the vises.
	Resonance of flexible tubes for inlet/exhaust.	Fix the resonant part.
	Pump parts damages.	Pump replacement or overhaul is needed.
	Cooling fan error	Pump replacement or overhaul is needed.
Insufficient Vacuum.	Pump error	Pump replacement or overhaul is needed.
	Pipe leakage in the fore line.	Check plumbing.
	The inside of the pump is dirty. (Moisture condensation etc.)	Pump overhaul is needed.
	The gas ballast valve is opened.	Close the gas ballast valve.
The breaker operates.	The capacity of the breaker is small	Use recommended breaker.
	Pump error	Pump replacement or overhaul is needed.
	Motor error	Motor replacement or overhaul is needed.
	Incompleteness of power supply or wiring	Repair the power supply and wiring.



## 8.2 Pump Malfunction

When abnormality occurs in the pump, the following message is displayed in the LED display of the operation panel.

In this case, please push the STOP/RESET switch of the operation panel after doing appropriate treatment. Abnormality is released.

### CONFIRMATION

At the trigger/alarm level (at the warning message departure report), there is a possibility that a sudden stop or breakdown occurs if driving is continued as it is though the pump doesn't stop.

LED Display		Contents	Cause	Corrective measures
Warning message	Err	Inverter reset	Inverter reset	*The RESET Input signal from the I/O connector is a make state. Put it into an open state.
	OL	Stall prevention (over current)	Overload operation Backing pressure rise	*Pump exchange or overhaul is needed *Check exhaust pipe
	oL	Stall prevention (over voltage)		
	TH	Electronic thermal relay function prealarm	Overload operation Backing pressure rise	*Pump exchange or overhaul is needed *Check exhaust pipe
	Uv	Under voltage	The power-supply voltage is abnormal	*Check voltage of power supply
Alarm message	E.OC1	Over current trip during acceleration	Pump error	*Pump exchange or overhaul is needed
	E.OC2	Over current trip during constant speed		
	E.OC3	Over current trip during deceleration or stop		
	E.Ov1	Regenerative over voltage trip during acceleration	Pump error	*Pump exchange or overhaul is needed
	E.Ov2	Regenerative over voltage trip during constant speed		
	E.Ov3	Regenerative over voltage trip during deceleration or stop		
	E.THT	Inverter overload trip (electronic thermal relay function)	Pump error Backing pressure rise	*Pump exchange or overhaul is needed *Check exhaust pipe
	E.THM	Motor overload trip (electronic thermal relay function)		
	*E.OHT	External thermal relay operation	The temperature of the motor is abnormal	*Pump exchange or overhaul is needed
	E.bE	Brake transistor alarm detection	Inverter error Pump error	*Check electric parts *Pump exchange or overhaul is needed
	E.GF	Output side earth (ground) fault over current at start		
	E.LF	Output phase loss		
	E.PE	Parameter storage device fault		
	E.PUE	Pu disconnection		
	E.rET	Relay count excess		
	E.5/ E.CPU	CPU fault		
E.CdO	Output current detection value exceeded			
E.IOH	Inrush current limit circuit fault			

\*) The external thermal relay setting is optional.

## 9. SCRAPPING METHOD

The pump main body and peripheral units may have been polluted by hazardous substances depending on each applied process.

Perform scrapping in compliance with the safety control standards of the nation and each local self-governing body.

## 10. PRECAUTIONS ON RETURN OF PRODUCT

### 10.1 Notes

When returning the pump and peripheral units to us for an overhaul, repair, etc. be sure to clarify the applied gas and products. This is duty-bound by the Industrial Safety and Health Law.

Before returning a unit, fill the Return Notice Sheet attached to this manual with necessary contents and submit it by FAX or mail. The user may have to return it to the approved dealer depending on the applied gas. The above request will lead to a smooth repair or overhaul.

If this sheet is not submitted, the returned product may be regarded as a hazardous substance and be rejected.

### 10.2 Returning Procedure

For a return, observe the following procedure.

- 1) Copy the Return Notice Sheet attached at the end of this manual and fill it with necessary contents.
- 2) Operate the pump while charging inert gas such as N<sub>2</sub> gas to remove toxic gas and corrosive gas completely from the pump. For the peripheral unit to be returned, eliminate toxic gas by charging inert gas. When solutions and lubricating oil can be disposed of properly on the user side, bleed them completely.
- 3) Admit compressed air into the cooling water line to drain the cooling water from the pump and remove all the accessories from the unit.  
(Refer to Page 35 7-3 Section 4 about how to drain the cooling water.)
- 4) Seal up the suction port and exhaust port of the pump by using blank flanges.
- 5) Seal up the product to be returned if possible after putting them in a polyethylene case or polyethylene sheet.
- 6) When returning the pump or unit, put the product to be returned on a wood pallet with a size of 510 mm x 915 mm or less and fix it with bands. In case of a large product which cannot be put on such a pallet, please ask us for information.
- 7) If the product to be returned is not so large as being fixed on a pallet, pack it in a solid case.
- 8) If the product to be returned is polluted, observe the law related to the transportation of hazardous substances, and stick a label having an indication to this effect on a pallet or case.
- 9) Submit the Return Notice Sheet filled with necessary contents to us by FAX or mail. This Return Notice Sheet should reach us earlier than the product to be returned.
- 10) Hand over a copy of the Return Notice Sheet to the forwarding agent. If the product to be returned is polluted, be sure to inform the forwarding agent of this effect.
- 11) Put the original of the Return Notice Sheet into an envelope and stick it on the outside of the product to be returned.

# Return Notice Sheet

Date : \_\_\_\_\_

## I. Product to be returned

i) Model No. of the product be returned \_\_\_\_\_

ii) Serial No. of the product to be returned \_\_\_\_\_

## II. Pollution of the product to be returned

i) Applied process name \_\_\_\_\_

ii) Pollutant table

	Pollutant name	Chemical symbol	Precaution on Handling	Action to be taken for accidental inhalation or touch
1				
2				
3				
4				
5				
6				

## III. Reason for return

i) \*Overhaul      \*Failure      \*Other (                      )

ii) Contents of failure

## IV. Person in charge and where to contact

Name : \_\_\_\_\_ (signature)                      Post : \_\_\_\_\_

Company name / plant name : \_\_\_\_\_

Address : \_\_\_\_\_

Telephone / FAX No. : TEL \_\_\_\_\_ FAX \_\_\_\_\_

Date of return : \_\_\_\_\_

