

Instruction Manual



Active Gauge Controller

Description

Item Number

<i>AGC - SINGLE DISP, NO RS232, 3 HEAD</i>	<i>D386-55-000</i>
<i>AGC - SINGLE DISP, NO RS232, 6 HEAD</i>	<i>D386-54-000</i>
<i>AGC - SINGLE DISP, NO R232, CM VER</i>	<i>D386-53-000</i>
<i>AGC - SINGLE DISP, RS232, 3 HEAD</i>	<i>D386-52-000*</i>
<i>AGC - SINGLE DISP, RS232, 6 HEAD</i>	<i>D386-51-000*</i>
<i>AGC - SINGLE DISP, RS232, CM VER</i>	<i>D386-50-000*</i>
<i>AGC - TRIPLE DISP, RS232, 3 HEAD</i>	<i>D386-62-000*</i>
<i>AGC - TRIPLE DISP, RS232, 6 HEAD</i>	<i>D386-61-000*</i>
<i>AGC - TRIPLE DISP, RS232, CM VER</i>	<i>D386-60-000*</i>
<i>AGC - NO DISPLAY, DEVICENET™</i>	<i>D386-65-000*</i>

Supplementary Manuals*

<i>Active Gauge Controller RS232 Option</i>	<i>D386-52-880</i>
<i>Active Gauge Controller DeviceNet™ Option</i>	<i>D386-65-880</i>



Declaration of Conformity

We, BOC Edwards,
Manor Royal,
Crawley,
West Sussex RH10 2LW, UK

declare under our sole responsibility that the product(s)

Active Gauge Controllers

AGC 1 line / RS232 / CAPMAN	D386-50-000
AGC 1 line / RS232 / STD	D386-51-000
AGC 1 line / RS232	D386-52-000
AGC 1 line / CAPMAN	D386-53-000
AGC 1 line / STD	D386-54-000
AGC 1 line	D386-55-000
AGC 3 line / RS232 / CAPMAN	D386-60-000
AGC 3 line / RS232 / STD	D386-61-000
AGC 3 line / RS232	D386-62-000

to which this declaration relates is in conformity with the following standard(s)
or other normative document(s)

EN61010-1:2001	Safety Requirements for Electrical Equipment for Measurement, Control and Laboratory Use.
EN61326:1997 + A1:1998 + A2:2001 (Class B Emissions)	Electrical Equipment for Measurement, Control and Laboratory Use - EMC Requirements.

following the provisions of

73 / 023 / EEC	Low Voltage Directive.
89 / 336 / EEC	Electromagnetic Compatibility Directive.



Dr. J.D. Watson, Director of Technology, VEMD

12 JULY 2004 CRAWLEY

Date and Place

This product has been manufactured under a quality system registered to ISO9001

 **BOC EDWARDS**

CONTENTS

Section	Title	Page
1	INTRODUCTION	1
1.1	Scope of this manual	1
1.2	General	1
2	TECHNICAL DATA	3
2.1	Mechanical data	3
2.2	Operating conditions	3
2.3	Electrical supply requirements	3
2.4	Electrical and electronic interface	3
2.4.1	AGC chart recorder output	3
2.4.2	Active gauge input/output	5
2.4.3	External relay outputs	5
2.4.4	Internal relay expansion board outputs	6
2.4.5	Capacitance manometer input/output	7
2.4.6	Maximum load	7
3	INSTALLATION	8
3.1	Unpacking and inspection	8
3.2	Locate the AGC	8
3.3	Electrical supply connection	8
3.4	Connect to the Active gauges and Capacitance manometer	9
3.5	Connect to the EXC turbo controller	9
3.6	Connect to the chart recorder outputs	9
3.7	Connect to the external relays	9
4	OPERATION	12
4.1	Front panel	12
4.2	Start the AGC	14
4.3	Gauge identification	14
4.4	Pressure and message display	15
4.5	Manual gauge control	16
4.6	Move through the menu	16
4.6.1	Sub menus and <input type="checkbox"/> prompt	17
4.7	Changing the value or status of a parameter	17
4.7.1	Status cycle	18
4.7.2	Select from a list	18
4.7.3	Move cursor and adjust digit	18
4.8	View menu	19

Section	Title	Page
4.9	System menu	21
4.9.1	Automatic gauge control	21
4.9.2	Relay control	22
4.9.3	Passwords	24
4.9.4	Reset	25
4.9.5	Serial communications	25
4.9.6	Units	25
4.10	Display menu	25
4.11	Ion gauge menus	27
4.11.1	Ion gauge sensitivity factor	28
4.11.2	Ion gauge emission current	29
4.11.3	Ion gauge degas	29
4.11.4	Qualification gauge	30
4.11.5	Auto Restrike	30
4.12	Active strain gauge control	30
4.12.1	ASG RANGE menu	30
4.12.2	ASG menu	31
4.13	Capacitance manometer control	32
4.13.1	CM RANGE menu	33
4.13.2	CM menu	33
4.14	Wide range gauge control	35
4.14.1	WRG menu	36
4.15	Turbo control	36
4.15.1	TURBO menu	37
4.16	Active linear pirani gauge (APGX) control	37
4.16.1	APGX menu	37
4.17	Active Ion gauge (AIGX)	38
4.17.1	AIGX menu	38
4.18	Memory backup	39
4.19	Error handling	39
5	MAINTENANCE	40
5.1	Fuse replacement	40
6	STORAGE AND DISPOSAL	40
6.1	Storage	40
6.2	Disposal	40
7	SPARES AND ACCESSORIES	41
7.1	Introduction	41
7.2	Relay expansion board kit	41
7.3	Cables	41
7.4	Active gauges	42
7.5	Capacitance manometer	42
7.6	Turbo controllers	42
RETURN OF BOC EDWARDS EQUIPMENT		

APPENDIX A	System menus	43
A1	User menu	45/46
A2	Ion gauge controller menu	47/48
A3	ASG menu	49/50
A4	CAPMAN menu	51/52
A5	WRG menu	53/54
A6	TURBO menu	55/56
A7	APGX menu	57/58
A8	AIGX menu	59/60
APPENDIX B	Default settings	61
APPENDIX C	Active gauge controller errors	62
C1	Major errors	62
C2	Major gauge errors	63
C3	Gauge errors	63
C4	Warning messages	64

Illustrations

Figure	Title	Page
1	Dimensions and installation requirements	4
2a	Rear panel	10
2b	Rear panel (Capacitance Manometer version)	10
3	Recommendations for earth connections	11
4	Typical connections for external relays	11
5	Front panel for single and three line displays	12
6	Start-up flow diagram	14
7	View auto display settings	20
8	Configuring the relays	23
9	Accessing the ion gauge menus	26

Tables

Table	Title	Page
1	Gauge power requirements	7
2	AGC operating keys	13
3	Gauge identification messages	15

1 INTRODUCTION

1.1 Scope of this manual

This manual provides installation, operation and maintenance instructions for the Edwards Active Gauge Controller. Read this manual before you install and operate the controller. Important information is highlighted as WARNING and CAUTION instructions; you must obey these instructions. The use of WARNINGS and CAUTIONS is defined below.

WARNING
Warnings are given where failure to observe the instruction could result in injury or death to persons.

CAUTION
Cautions are given where failure to observe the instruction could result in damage to the equipment, associated equipment or process.

The units used throughout the manual conform to the SI International system of units of measurement.

In accordance with the recommendations of EN61010, the following warning symbols appear on the Active Gauge Controller:



Caution - refer to accompanying documents



BOC Edwards will offer European customers a recycling service.



1.2 General

The Edwards Active Gauge Controller (AGC) is used with the Edwards Active vacuum gauges. The AGC interfaces directly to 3 or 6 (depending on the AGC model) Active vacuum gauges providing a comprehensive control and display system.

There are ten models available:

AGC - SINGLE DISP, NO RS232, 3 HEAD	Single line display 3 heads
AGC - SINGLE DISP, NO RS232, 6 HEAD	Single line display 6 heads
AGC - SINGLE DISP, NO RS232, CM VER	Single line display 6 heads capacitance manometer version
AGC - SINGLE DISP, RS232, 3 HEAD	Single line display 3 heads, with RS232 interface

AGC - SINGLE DISP, RS232, 6 HEAD	Single line display 6 heads, with RS232 interface
AGC - SINGLE DISP, RS232, CM VER	Single line display 6 heads, capacitance manometer version, with RS232 interface
AGC - TRIPLE DISP, RS232, 3 HEAD	Three line display 3 heads, with RS232 interface
AGC - TRIPLE DISP, RS232, 6 HEAD	Three line display 6 heads, with RS232 interface
AGC - TRIPLE DISP, RS232, CM VER	Three line display 6 heads, capacitance manometer version, with RS232 interface
AGC - NO DISP, DEVICENET™	No display 6 heads, capacitance manometer version, with DeviceNet™ interface

You can use any of the following gauges with the AGC:

Active Pirani	APG-M, APG-L
Active Inverted Magnetron	AIM-S, AIM-X
Active Thermocouple	ATC-M, ATC-D with ATC-E
Active Ion Gauge	IGC-IR, IGC-EBEAM, AIGX
Active Strain Gauge	ASG
Wide Range Gauge	WRG
Active Linear Pirani	APGX
Linear Convection Gauge	APGX-H

In addition you can use the Barocel 590 and Barocel 600 series with the CM VER models of the AGC.

A link can be made between the AGC and any of the Edwards EXC turbo controllers which allows the AGC to control the turbo pump (and depending on EXC version, the backing pump as well) and for the turbo pump speed to be used by the AGC to control gauges and relays. If the AGC has an RS232 port then this link also allows the turbo pump to be controlled via RS232 (refer to AGC RS232 option supplementary instructions D386-52-880).

The single line models of the AGC display information from one gauge at a time, the three line display models can display information from three different gauges simultaneously.

Gauges can be turned on and off manually from the front panel or can be programmed to switch on automatically when the pressure measured by another gauge reaches a pre-set level.

The display and control features of the AGC are accessed through a menu structure. You move through the menu with simple keystroke combinations entered from the front panel. Security of gauge settings is achieved by a two level password system which restricts access to certain areas of the menu. In addition, the AGC can be interfaced to other microprocessor and data acquisition systems through an optional serial RS232 communications link.

The AGC has 6 outputs which can be programmed as gauge pressure set points and so used to control the operation of auxiliary equipment. An optional relay board can be fitted which increases the load capability of these outputs.

The AGC has one chart recorder output for each gauge channel (3 or 6 depending on version). These give an analogue output in the range 0 to 10 V corresponding to the pressure measured by the gauge.

2 TECHNICAL DATA

2.1 Mechanical data

Case dimensions	See Figure 1 (equivalent to 2U half 19 inch rack mount)
Mass (unpacked)	5.5 kg

2.2 Operating conditions

Temperature range	
Operating	0 °C to 40 °C
Storage	-20 °C to 70 °C
Relative humidity (non-condensing)	
Operating and storage	10 to 90 %
Maximum operating altitude	2000 m
Installation category - IEC1010	1
Pollution category - IEC1010	2
Enclosure rating	IP205

2.3 Electrical supply requirements

Input voltage range	90 - 265 V a.c. (rms)
Input frequency range	45 - 70 Hz
Power consumption	50 W
Fuse rating	2 A (Type T , slow blow)

2.4 Electrical and electronic interface

The rear panel of the AGC has the electrical input, electrical supply on /off switch and all interfacing, expansion board and active gauge sockets. Refer to Section 3 for connection details.

2.4.1 AGC chart recorder output

Connector type	5 pin, 180 ° DIN Socket
Maximum load	10 kΩ
Maximum current source	1 mA

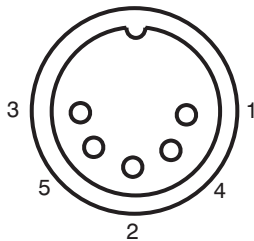

Pin	Allocation	
	Standard gauges 1 - 3	Expansion gauges 1 - 3
1	Gauge 1 +ve	Gauge 4 +ve
2	Common	Common
3	Gauge 2 +ve	Gauge 5 +ve
4	Gauge 3 +ve	Gauge 6 +ve
5	No connection	No connection

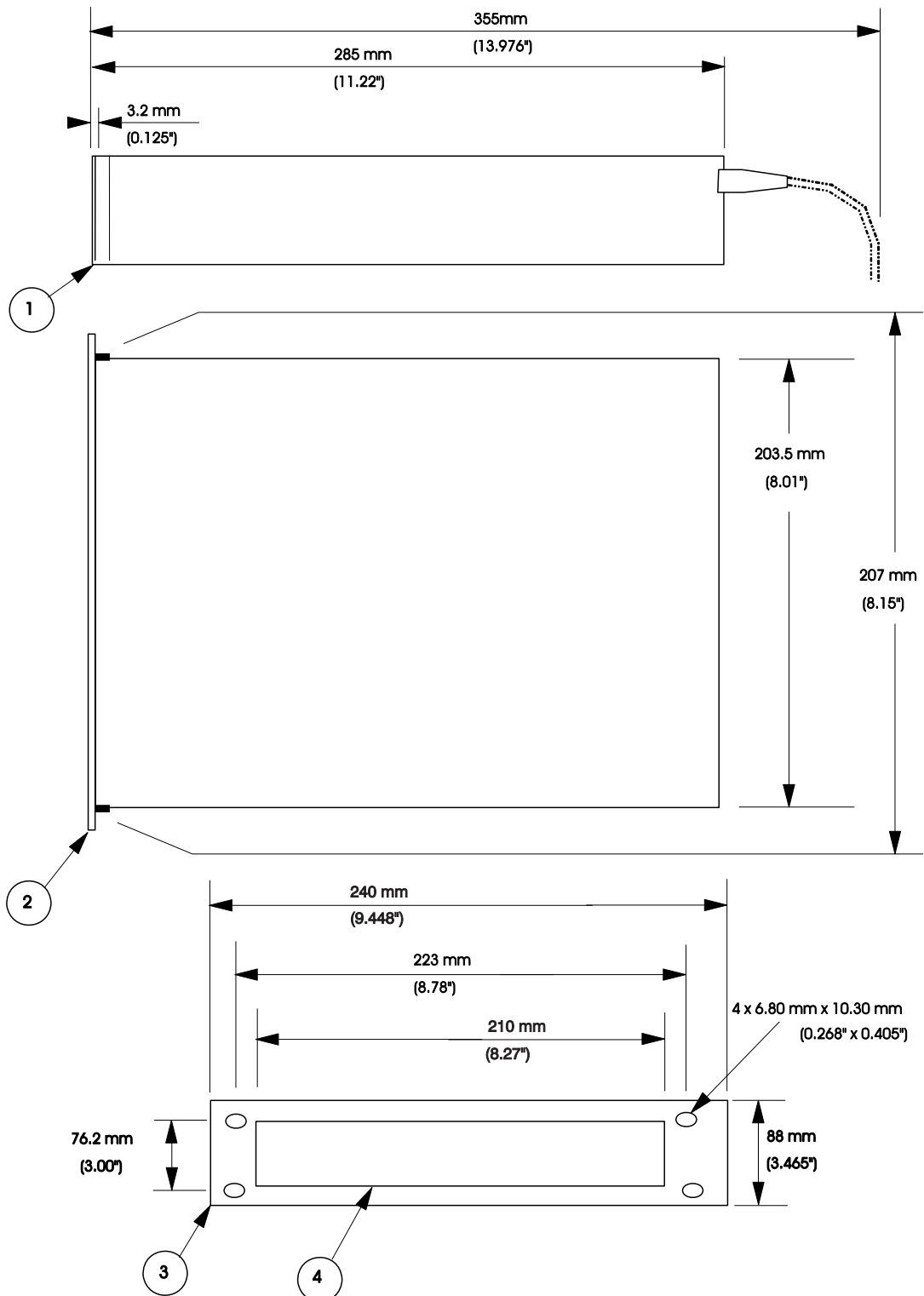

1. Side view
2. Top view
3. Front panel view
4. Size of front panel cut-out

Figure 1 - Dimensions and installation requirements

2.4.2 Active gauge input/output

Note: Output is short term short circuit protected and long term overload protected.

Connector type	FCC68/RJ45
Power supply	26 V d.c. (nominal)
Maximum power rating	18 W (See Section 2.4.6)
Input voltage range	-0.5 to 15 V d.c.
Output signal	0 to 10 V d.c. (Equal to gauge signal output voltage)

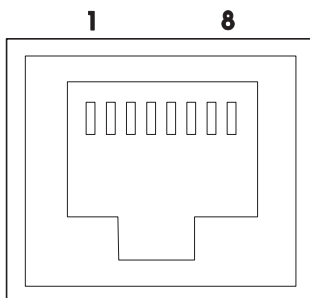

Pin	Allocation
1	Power supply +ve
2	Power supply common
3	Signal input
4	Gauge identification
5	Signal common
6	Control 1
7	Control 2
8	Control 3

2.4.3 External relay outputs

Connector plug	10 pin IDC
	6 open collector transistor outputs
Maximum voltage	40 V d.c.
Maximum current	100 mA

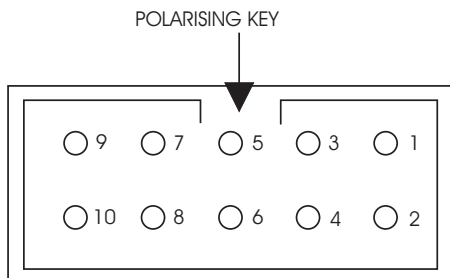

Pin	Allocation
1	Open collector output 1
2	Open collector output 2
3	Open collector output 3
4	Open collector output 4
5	Open collector output 5
6	Open collector output 6
7	Not used
8	Not used
9	Common
10	+ 24 V d.c.

2.4.4 Internal relay expansion board outputs (optional accessory)

WARNING

You must use suitable wires and cables to connect to the relay expansion board. If you do not, this will result in inadequate strain relief and a possible safety hazard. The connector will NOT provide adequate strain relief for PTFE insulated wires and cables.

Connector type	20 way Positronic 6 electromagnetic relays
Maximum voltage rating	240 V a.c.
Maximum current rating	3 A (for non inductive load)
Isolation	500 V d.c. between contact sets 3 kV to chassis. 5 kV to internal low voltage circuits

The relay connector has been designed to accept individual wires (2 - 18 wires) or a single multiway cable (2 - 18 cores) conforming to:

- 16 strand, strand diameter 0.2 mm, PVC insulated
- Overall diameter 1.6 mm
- Maximum cable diameter 15 mm over outer jacket

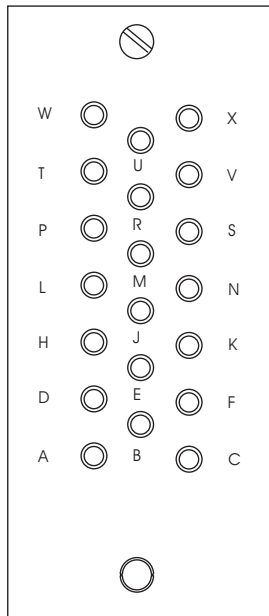

Pin	Allocation	Relay
P W T	Normally closed Common Normally open	1
A H D	Normally closed Common Normally open	2
U M R	Normally closed Common Normally open	3
K C F	Normally closed Common Normally open	4
B J E	Normally closed Common Normally open	5
X S V	Normally closed Common Normally open	6

2.4.5 Capacitance manometer input/output*

Note: Output is short term short circuit protected and long term overload protected.

Connector type	FCC68/RJ45
Nominal electrical supply (Barocel 590)	26 V d.c.
Nominal electrical supply (Barocel 600)	± 15 V d.c.
Maximum power rating	10 W (See Section 2.4.6)
Input voltage range	-0.5 to 15 V d.c.

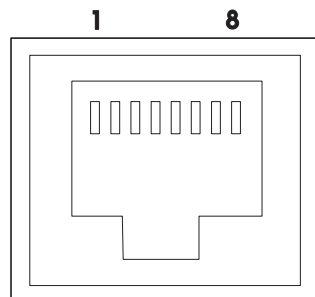

Pin	Allocation
1	Power supply +ve
2	Power supply 0 V
3	Signal input
4	Gauge identification
5	Signal common
6	Control 1
7	Control 2
8	Power supply -ve

*Provided only on CM VER AGC's

2.4.6 Maximum load

The total power taken by all connected gauges must not exceed 18 W. The total power of channels 4, 5, and 6 must not exceed 10 W. The power requirements of the Active gauge heads are such that all combinations of heads are possible without exceeding the maximum load. The power requirements of the 655 capacitance manometer and the AIGX however is significantly greater and care needs to be taken calculating the total load when these gauges are used. A summary of power requirements of the most common compatible gauges is given in Table 1. For further details the appropriate gauge head instruction manual should be consulted.

Gauge	Maximum power use (W)
WRG	2.0
APG	1.5
APGX	2.0
ATC	0.6
AIM	3.0
ASG	0.3
AIGX	8.0
AIGX (degas)	15.0
BAROCEL 590	2.0
BAROCEL 600	1.0
BAROCEL 622	1.0
BAROCEL 655	7.5

Table 1 - Gauge power requirements

3 INSTALLATION

3.1 Unpacking and inspection

Remove all packing materials and protective covers and check the Controller. If the Controller is damaged, notify your supplier and the carrier in writing within three days; state the Item Number of the Controller together with your order number and your supplier's invoice number. Retain all packing materials for inspection. Do not use the Controller if it is damaged.

Check that your package contains the following items:

Qty	Description	Check
1	Active Gauge Controller	
1	Chart recorder plug (3 channel)	
2	Chart recorder plugs (6 channel)	
4	Self adhesive plastic feet	

If any of these items are missing, please notify your supplier in writing within 3 days.

3.2 Locate the AGC

The AGC must be horizontal and can be used on a bench top or can be fitted into a rack or cabinet. If you use the AGC on a bench-top, you must fit the self adhesive feet supplied with the controller, to give 10 mm clearance below the controller for ventilation.

If you fit the AGC in a rack or cabinet, you must allow 10 mm clearance around the controller (for ventilation) and 70 mm clearance at the back of the controller (for the cables). The size of the front panel cut-out required and the location of the front panel fixing holes are shown in Figure 1.

3.3 Electrical supply connection

Ensure that the electrical supply switch is set to off and connect the AGC to the electrical supply with an appropriate supply cable (refer to Section 7). If necessary, you must use a suitably rated electrical supply plug, connecting the wires as shown in the following table:

Wire colour	Function
Green/Yellow	Earth/ ground
Brown	Live/line
Blue	Neutral

Connect the earth stud on the rear panel to your vacuum system earth. When you use the AGC with Ion Gauge Controllers it is important that all units are connected directly to the same earth point (star earth connection) as shown in Figure 3.

3.4 Connect to the Active gauges and Capacitance manometers

CAUTION

The correct electrical supplies for the Barocel 600 series are only available from inputs 4, 5 and 6 on the CM VER AGCs. If you connect a Barocel 600 series to any other input you may damage the Barocel. Check that you have the correct type of AGC before you connect a Barocel 600 series.

Note: When you change gauges do not plug in the new gauge too quickly. It is advisable to leave 10 seconds between plugging and unplugging actions to ensure recognition by the software.

Connect Active gauges to the 3 or 6 (depending on AGC model) gauge connectors on the rear panel using Edwards Active gauge cables. Connect capacitance manometers to appropriate gauge connectors on the rear panel (refer to section 4.13) using Edwards Active gauge cables and capacitance manometer adapter cables. Refer to section 7.3 for details of cables.

3.5 Connect to the EXC turbo controller

The link between AGC and EXC is made in a very similar way to connecting a gauge to the AGC. A combination of appropriate AGC/EXC adapter cable and a standard Active gauge cable should be used to connect the EXC to any of the AGC gauge sockets (refer to section 7.3 for details of cables). Note that any additional connections that are required to the EXC controller such as vent valve, air cooler, etc. should be made in accordance with the EXC instructions but links should not be made connecting the start/stop inputs or TMP interlock inputs.

3.6 Connect to the chart recorder outputs

Connect the chart recorder outputs to your chart recorder from one of two sockets (depending on AGC model) located on the rear panel of the AGC. Refer to Section 2.4.1 for output load specifications and pin usage details.

3.7 Connect to the external relays

Note: When you use the active gauge 24 V d.c. supply to drive external relays the total power consumption must be less than 5 W (non-inductive).

Note: Do not use the active gauge 24 V d.c. supply when the relay expansion board is fitted to the AGC.

Figure 4 shows how to use the 6 outputs (pins 1 to 6) for external relay connections. External relays can be powered by the 24 V d.c. available at the 10 way plug or by an independent power supply. Connect the outputs through a 10 way plug. Refer to Section 2.4.3 for pin usage details.

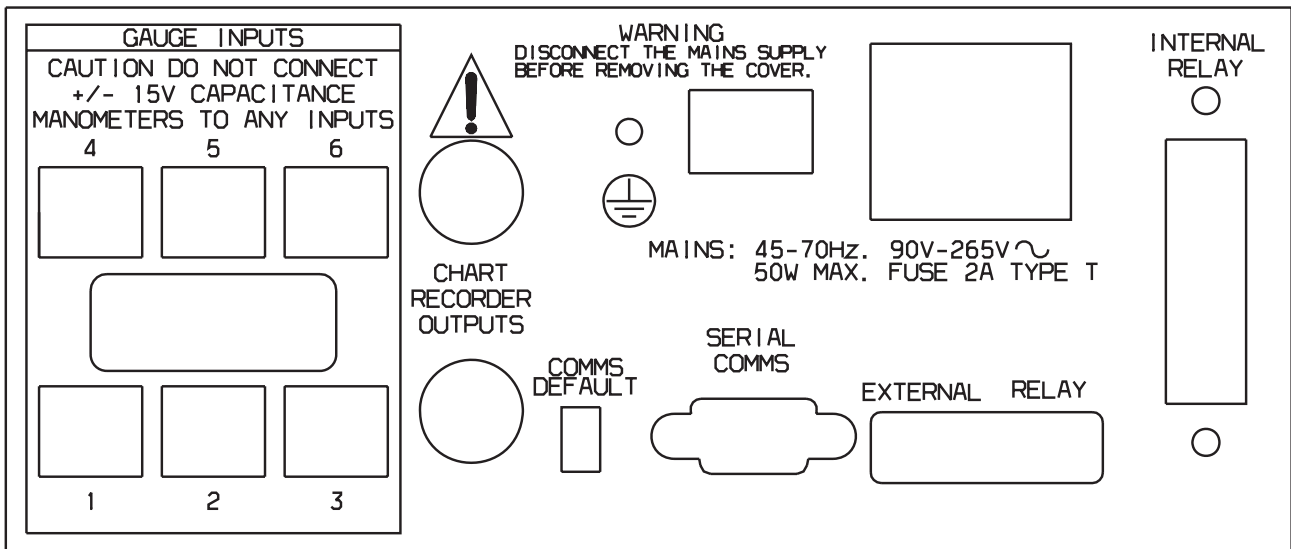

Figure 2a - Rear panel (all variants except Capacitance Manometer)

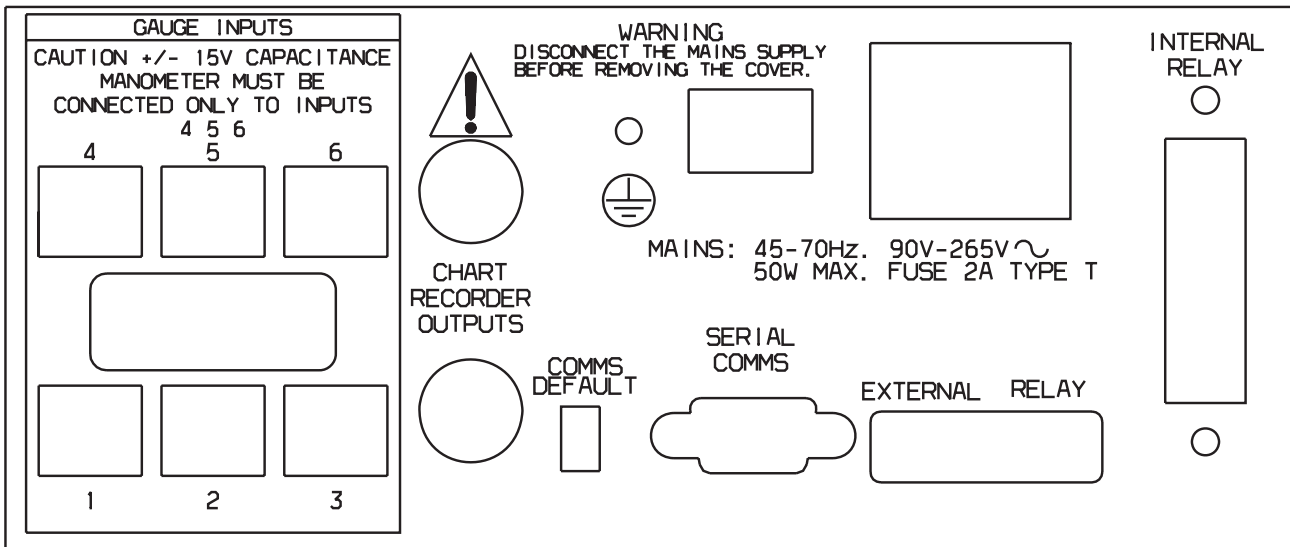

Figure 2b - Rear panel (Capacitance Manometer version)

Note: The caution label on Figure 2b has been modified to incorporate the Capacitance Manometer version only.

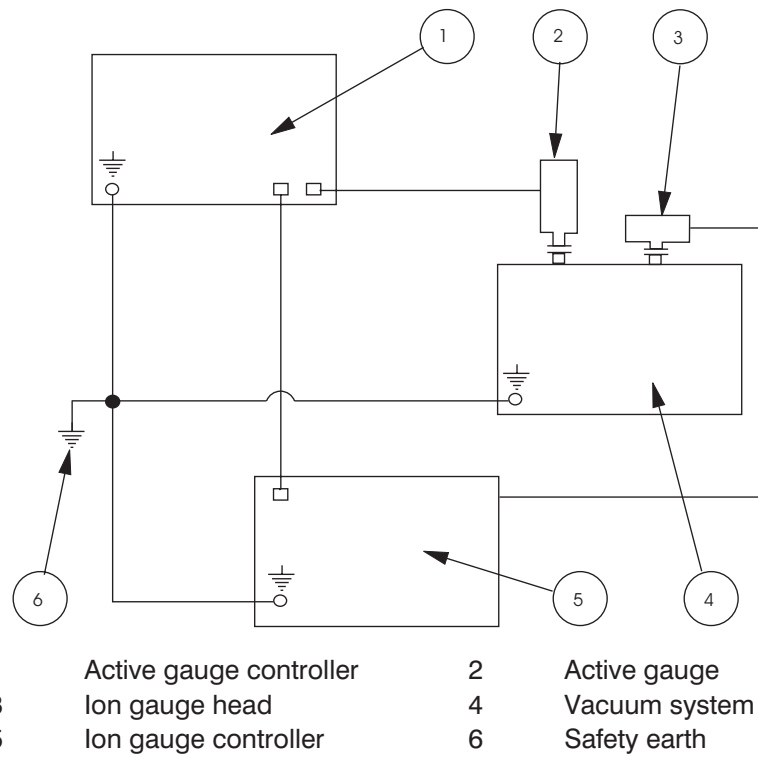
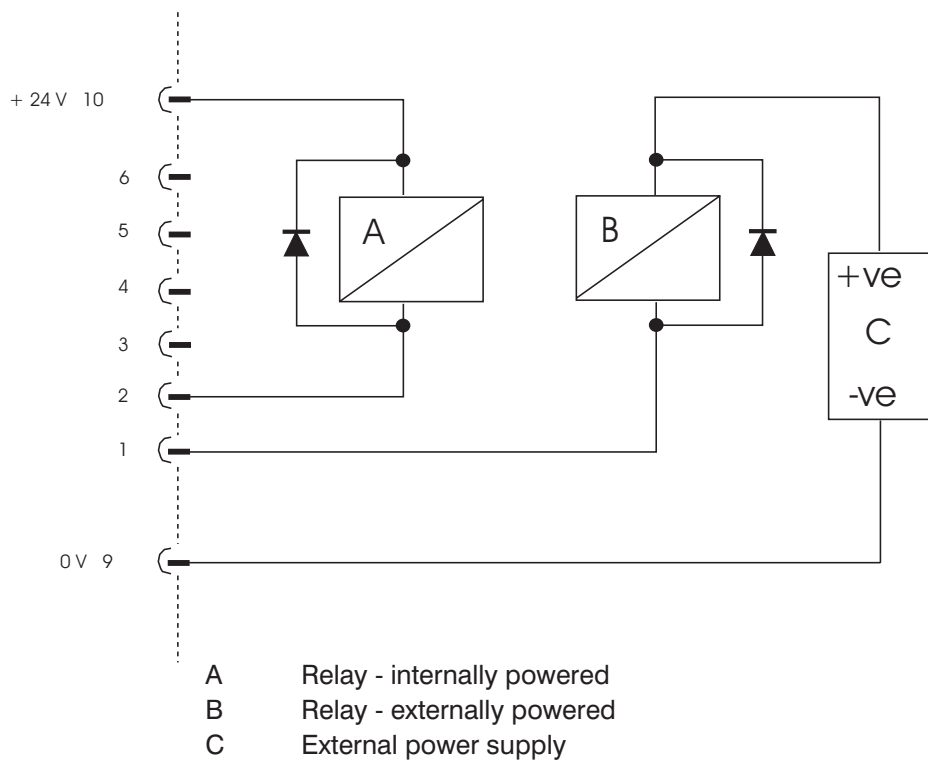

Figure 3 - Recommendation for earth connections



Note: Do NOT connect pins 7 and 8.

Figure 4 - Typical connections for external relays

4 OPERATION

4.1 Front panel

WARNING

The unit is not fail safe. You must ensure that incorrect operation does not cause a hazard.

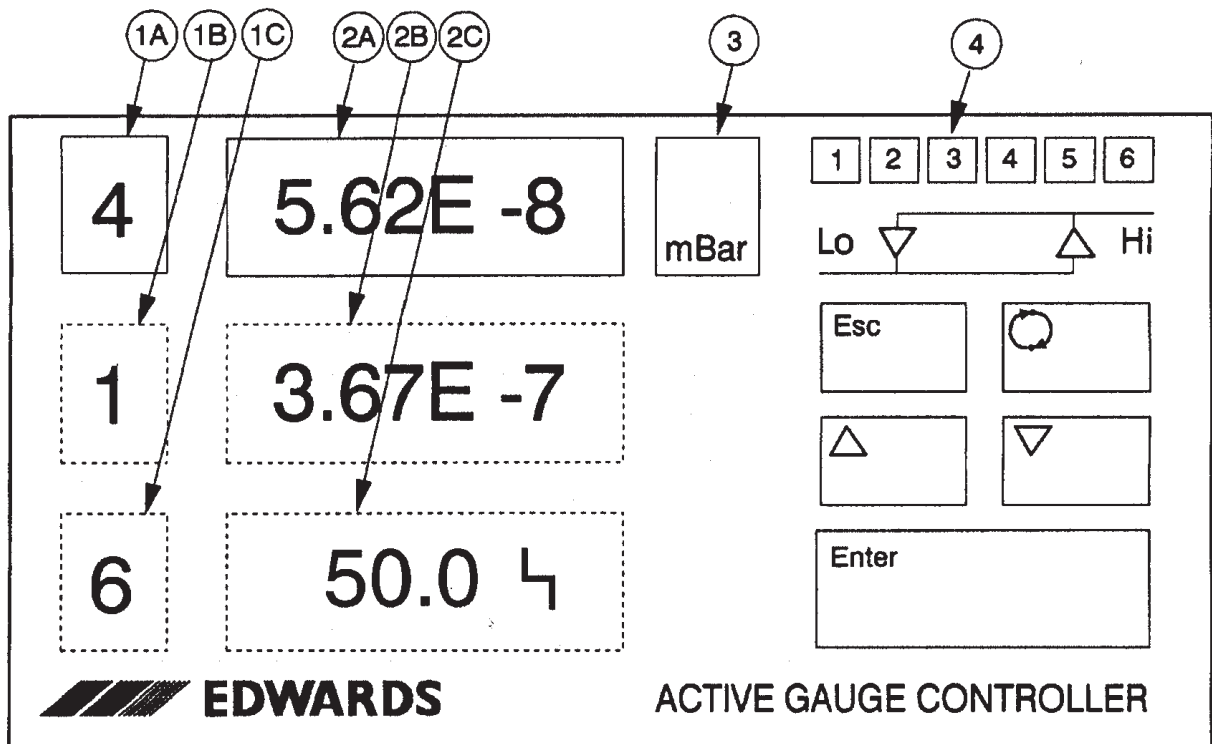

- 1A Line 1 - Gauge channel indication
- 2A Line 1 - 6 alpha numeric characters display
- 1B Line 2 - Gauge channel indication
- 2B Line 2 - 6 alpha numeric characters display
- 1C Line 3 - Gauge channel indications
- 2C Line 3 - 6 alpha numeric characters display
- 3 Pressure unit indication - Pascal, torr or mbar
- 4 Set point indicators

Figure 5 - Front panel for single and three line displays
(Dotted areas represent the second and third lines of the three line display option.)

Figure 5 shows the front panel for both the single and three line display AGCs. Each line has a seven character display. They are used to show gauge channel, gauge type, pressure readings, errors and menu text. Item 3 on Figure 5 shows one of the three indicators used to indicate the pressure units (Pascal, torr or mbar). Six indicators, Item 4, show the relay status (illuminated = relay 'on' or energised). Two further indicators are used when setting up the hysteresis for a relay. "Lo" is the lower hysteresis (low pressure) set point and "Hi" is the upper hysteresis (high pressure) set point.

The five buttons are used to select and operate gauge heads and to move through the menu structure, and have the following functions and function names. In the text the buttons are referred to by their function name only.



Symbol	Name	Function
	UP	Move up through selection of gauge heads. Move up through a menu or to increase a numerical value. Cycle values (for example, between 1 and 0).
	DOWN	Move down through selection of gauge heads. Move down through a menu or to decrease a numerical value. Cycle values.
	CYCLE	Clear gauge errors. Cycle values and to move the cursor from left to right when entering passwords and numerical values. Turn gauges on and off manually.
Enter	ENTER	Cycle gauge channel pressure and identification readings. Enter a sub-menu nested below the current menu item. Enter a password or parameter value. Clear error messages.
Esc	ESCAPE	Exit menus and sub-menus. Abort function and parameter changes before the ENTER button is pressed. Used in conjunction with the ENTER button to gain access to the strain gauge, capacitance manometer and ion gauge menus.

Table 2 - AGC operating keys

4.2 Start the AGC

Note: The error messages are listed in Appendices C1, C2, C3 and C4.

See the flow diagram (Figure 6) for sequence of operation.

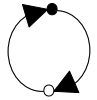
- Use the electrical supply switch on the rear panel to switch on the AGC.
- INIT will be displayed.
- If no error exists, a gauge pressure reading (or OFF for a disabled AIM or ION gauge) will be displayed. If there are no gauges fitted then either an error message or NONE will be displayed.

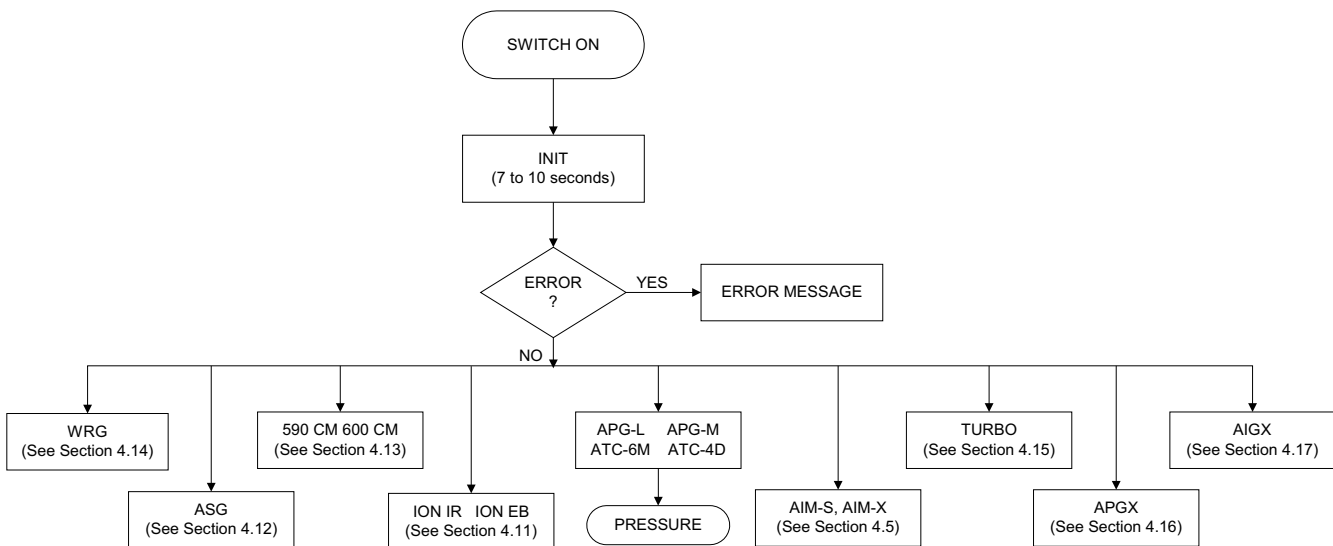

Figure 6 - Start-up flow diagram

4.3 Gauge identification

Note: When you change gauges do not plug in the new gauge too quickly. It is advisable to leave 10 seconds between plugging and unplugging actions to ensure recognition by the software.

If the gauges connected to the AGC have changed (that is, gauges removed or added) since the AGC was last switched on, the AGC will display NEW ID. Press ENTER to accept each change in gauge.

Compatible gauge types and their identification messages are shown in Table 3.

Gauge type	Identification message
Wide Range Gauge	WRG
Active Pirani APG-M	APG M
Active Pirani APG-L	APG L
Active Inverted Magnetron AIM-S	AIM S
Active Inverted Magnetron AIM-X	AIM X
Active Thermocouple - 6M Tube	ATC 6M
Active Thermocouple - 4D Tube	ATC 4D
Ion Gauge Controller - IGC - Resistive degas	ION IR
Ion Gauge Controller - IGC - E Beam degas	ION EB
Active Strain Gauge	ASG
Linear Pirani Gauge	APGX
Linear Convection Gauge	APGX-H
Active Ion Gauge - AIGX	AIGX
Capacitance manometer Gauge - 500 Series	590 CM
Capacitance manometer Gauge - 600 Series	600 CM
Turbo Controller	TURBO

Table 3 - Gauge identification messages

If the AGC cannot identify a gauge then the ident ??? is displayed. Only channels with gauges connected are accessible.

4.4 Pressure and message display

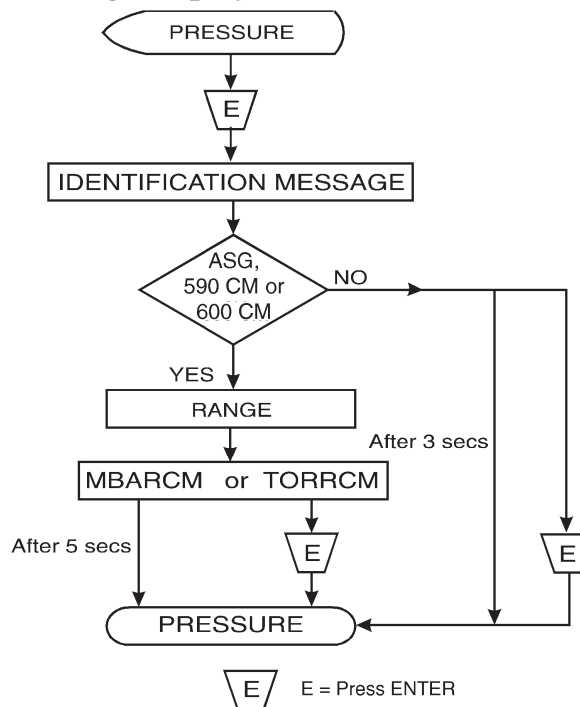

The first digit of the display is the gauge channel number which relates directly to the socket into which a gauge is plugged. The next six digits show the pressure reading, turbo speed (or an appropriate message) for that channel, see Figure 5.

Display lines 2 or 3 can only display pressures, turbo speed or off. If an Active gauge allocated to display line 2 or line 3 is disconnected or is faulty, the corresponding display line will show a blank. If the gauge was disconnected, line 1 will indicate a flashing NEW ID until you press ENTER to clear the message.

4.5 Manual gauge control

Note: Switching off a strain gauge or capacitance manometer disables the gauge but does not remove power from the gauge. Switching off an AIM gauge disables the gauge, removing the high voltage generated within the gauge but does not remove power from the gauge.

AIM, ION, strain and capacitance manometer gauges as well as turbo controllers can be turned on and off.

Press the CYCLE button to manually turn the gauge on and off when reading the gauge pressure (or turbo speed). When a gauge is turned off the display will show the channel number and OFF.

AIM gauges

When an AIM gauge is turned on the message SRKING will be displayed. When the gauge strikes, a pressure reading will be shown. If the gauge fails to strike within 15 minutes then the error message NOTSRK will be displayed and the gauge will be turned off. Press CYCLE to try again.

Ion gauges

When an Active ion gauge is turned on, IGENIS is displayed momentarily before the pressure reading. This message indicates that the ion gauge emission is being stabilised. If any errors occur then the appropriate message will be displayed; for example, EM ERR (refer to Section 4.11). If ion gauge turn on is inhibited (Section 4.11.4) then the on or off cycle is suppressed and IG INH is displayed.

Strain gauges and capacitance manometers

The default status for these gauges is on. Switching them off simply replaces the pressure display with the message OFF.

Turbo controllers

The default status for a turbo is off. Refer to section 4.15 for details of turbo pump control.

4.6 Move through the menu

The control and display features of the AGC are accessed through separate menus: USER, ION, ASG, CM, WRG, APGX, AIGX and TURBO (shown in Appendix A).

General system control and display features are contained in the USER menu. The ION, ASG, CM, WRG, APGX, AIGX and TURBO menus contain functions specific to these products and are covered in Sections 4.11 to 4.17.

4.6.1 Sub menus and □ prompt

The top level of the USER menu contains two items (three items if a three line display is fitted):

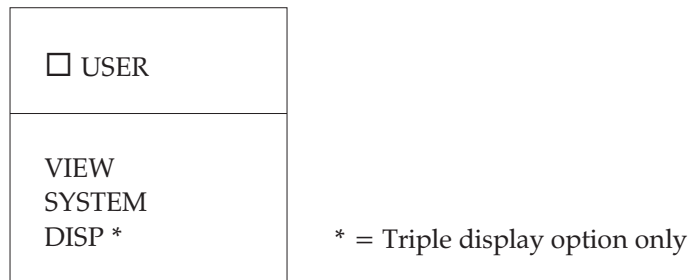

Each of these menu items has a sub-menu containing further items.

Press ESCAPE to enter the USER menu. The message USER will be displayed prefixed by a □ symbol. Press the UP/DOWN buttons to scroll through the items in this menu.

Press ENTER to access other sub-menus. Press UP/DOWN to move to an item which has a new sub-menu level associated with it (for example, VIEW), press ENTER, the display now shows VIEW preceded by the □ symbol. Access is now provided to the view menu which contains the following items:

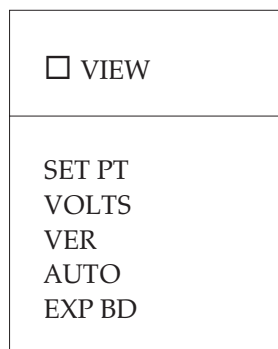

Not all items give access to further menu levels. Press ENTER on these items to display either a numerical value or a text message indicating the status of the item selected. Press ESCAPE to move back up through the menu levels. In this mode the ESCAPE button has the opposite function to ENTER.

4.7 Changing the value or status of a parameter

The ENTER, CYCLE, UP/DOWN and ESCAPE keys are used to change the value or status of a parameter. See Table 2.

Press the CYCLE or UP or DOWN buttons to change the parameters, press ENTER to action the change. Press ESCAPE to exit the setting procedure with the value unmodified before you press ENTER. Appendix B lists the default settings for all parameters.

4.7.1 Status cycle

Parameters which have only two settings (such as on or off) are adjusted using this mode. Press the CYCLE or UP/DOWN buttons to cycle between the two possible values. Press ENTER to validate the setting.

4.7.2 Select from a list

Parameters can have a range of settings held in a sub menu. Press the UP/DOWN buttons to move through the list, press ENTER to select the value. The numerical position of the value selected in the sub-menu list is then displayed at the front of the menu item. For example the pressure units can be set to one of the following in the UNITS menu:

<input type="checkbox"/> UNITS
1 MBAR
2 PASCAL
3 TORR

When ENTER is pressed, UNITS is displayed followed by the number corresponding to the item selected from the list.

4.7.3 Move cursor and adjust digit

CAUTION
The minimum exponent value is -9 (that is, the lowest pressure setting is 1.00E -9), so that an entry of 0.20 E-9 will become 2.00 E-9 and an entry of 0.07 E -8 will become 7.00 E-9.

Note: When you enter a pressure in the form 0.xx Ey or 0.0x Ey the mantissa and exponent are normalised to read x.xx Ey, for example, 0.03 E-3 will become 3.00 E-5 after ENTER is pressed.

Use this mode to set numerical parameters such as pressures and passwords. The numerical parameter is displayed in scientific notation, that is, mantissa, exponent sign and exponent. Press ENTER to select the menu item, the first digit of the mantissa will flash. The flashing digit indicates the current position of the adjustment cursor. Press the CYCLE button to move the cursor left to right. Press the UP/DOWN buttons to change the value of the digit that is flashing. Pressing and holding the UP/DOWN or CYCLE buttons will increment, or decrement, parameters automatically.

4.8 View menu

The VIEW menu is accessed directly from the USER menu, it contains the following items:

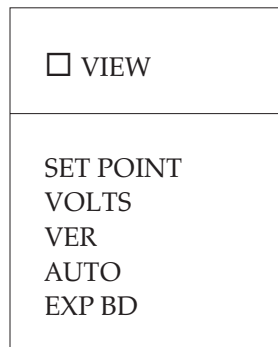

The VIEW menu is used to examine current parameter settings, no adjustment of values can be performed.

Select SET PT to display the relay set point values. Press the UP/DOWN buttons to select relay upper or lower set point. The display shows the control channel and the set point pressure, or OFF, ON or FAULT .

Select VOLTS, press the UP/DOWN buttons to display the channel input voltage. The VOLTS item is used to show the gauge voltage signal inputs.

Select VER to display the software version number. This should always be quoted in correspondence with BOC Edwards concerning the AGC.

Select AUTO to display any automatic gauge control settings that have been made (see Section 4.9.1). The method of displaying these settings is shown in Figure 7.

Select EXP BD to display the type of gauge channel expansion board fitted. STD means that a standard active gauge expansion board is fitted, that is, channels 4 to 6 available for use with active gauges. CAP indicates that the capacitance manometer expansion board is fitted allowing the connection of 600 Series Barocels to channels 4, 5 or 6.

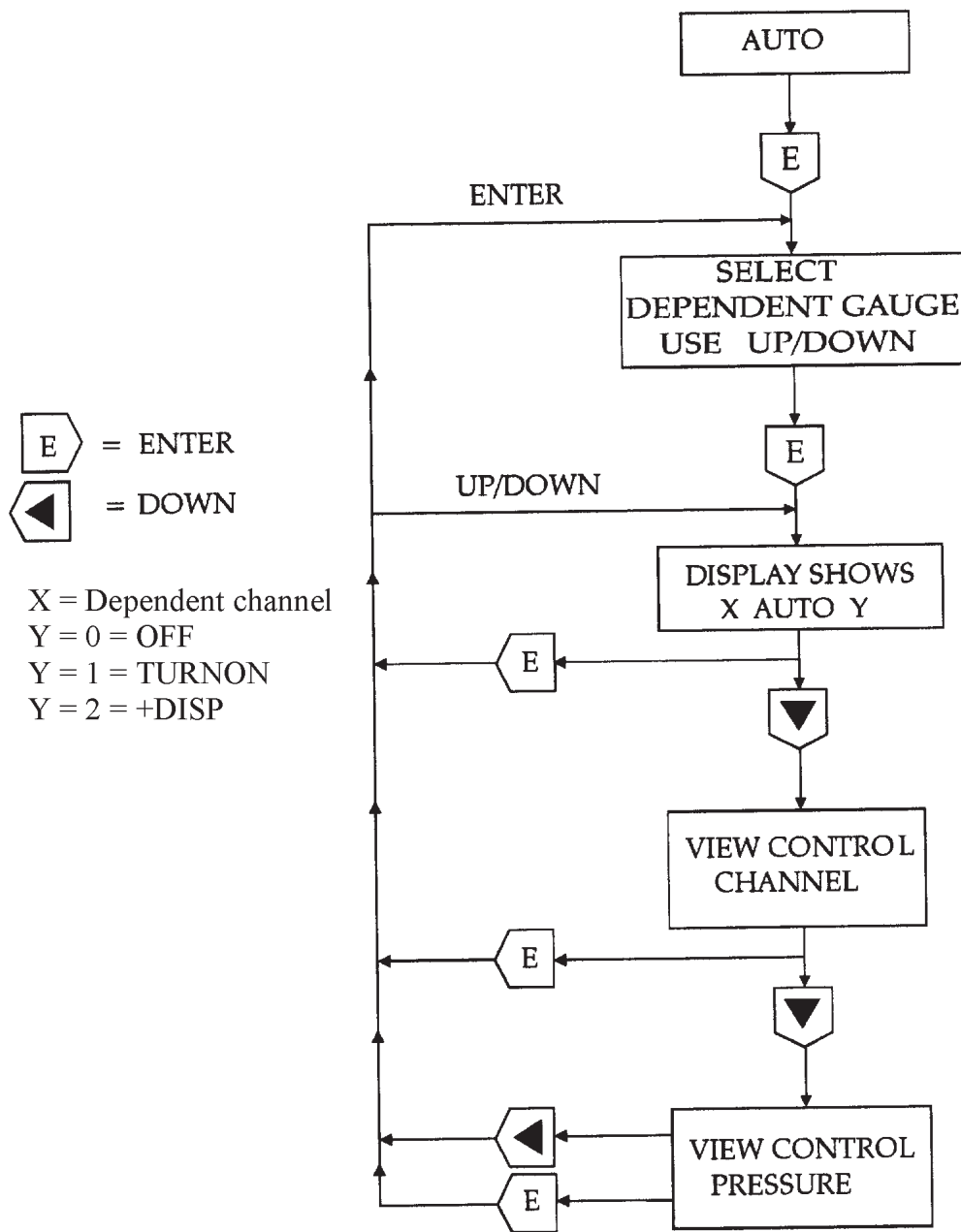

Figure 7 - View auto display settings

NONE is displayed instead of X AUTO Y if no channels have been set up for automatic control

4.9 System

4.9.1 Automatic gauge control

Note: Switching off a strain gauge or capacitance manometer disables the gauge but does not remove power from the gauge. Switching off an AIM gauge disables the gauge, removing the high voltage generated within the gauge but does not remove power from the gauge.

AIM, ion, strain and capacitance manometer gauges as well as the EXC turbo controller can be turned on and off automatically by other gauges at pre-defined pressures. Select AUTO from the SYSTEM menu to set up this feature. Once AUTO is selected the procedure is as follows:

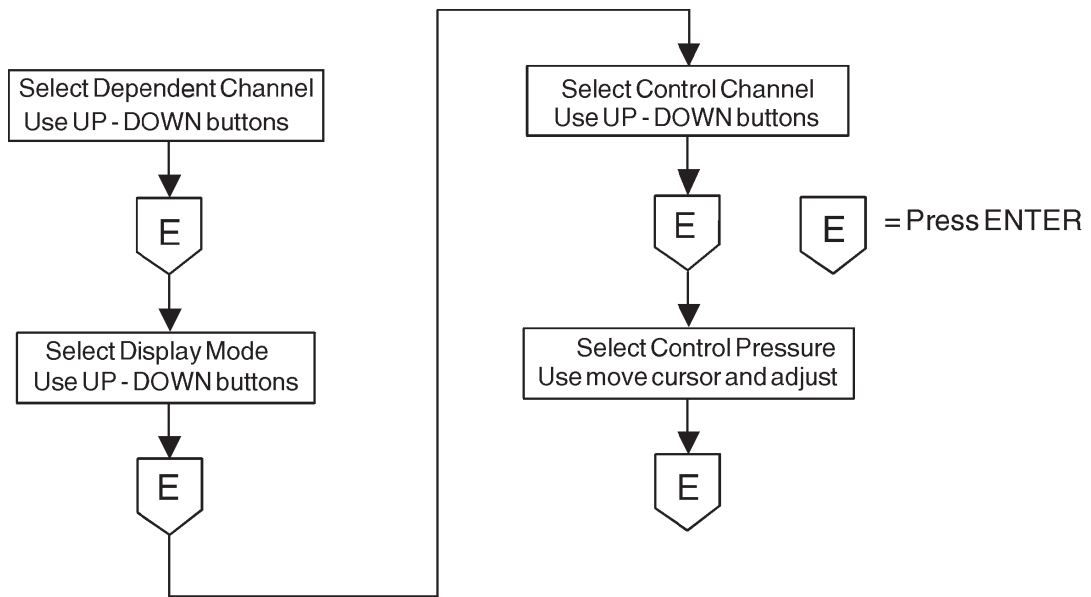

The display mode determines how the dependent gauge channel indicates the pressure. There are two settings TURNON and + DISP whose function is shown in the following table:

Display mode state	Dependent gauge state	Dependent gauge channel display	Gauge channel decimal point status
TURNON	OFF	OFF	OFF
TURNON	ON	Dependent gauge pressure	OFF
+DISP	OFF	Control gauge pressure	ON

Note: The + DISP display mode should not be used when using a gauge to control a turbo pump.

All available gauge channels can be configured as control or dependent gauges. All gauge types can control, but only AIM, ion, strain, capacitance manometer gauges and turbo controllers can be dependent.

When in + DISP mode, the decimal point segment on the gauge channel indicator will turn on to indicate that the control gauge pressure is being displayed.

Press the CYCLE button to manually switch off gauges that are auto controlled. A gauge switched off manually can be switched back on again by manually pressing the CYCLE button only if the controlling gauge is in the "on" pressure region.

When a gauge is turned off (manually or automatically) all of its dependent gauges are turned off.

If a controlling gauge is disconnected, then any dependent gauges will be turned off. The automatic gauge control must be re-configured to OFF to allow manual control of the dependent gauges.

If a gauge error is detected (see Section 4.17 and Appendix C) then all gauges controlled by that gauge will be turned off until the error has been cleared.

The control pressure has a preset 125 mV hysteresis, that is, if the voltage output of the controlling gauge increases by 125 mV above its value at the control pressure then the dependent gauge will be turned off. Refer to the gauge operating instructions for voltage to pressure conversion tables.

Select AUTO in the VIEW menu to view the automatic control settings, refer to Section 4.6.

When using a capacitance manometer to control another capacitance manometer (for example, a 1000 mbar device to control a 10 mbar device) the 125 mV hysteresis would result in an overrange display for the 10 mbar device as the pressure rises, if the turn-on pressure was 10 mbar. In these circumstances the turn on pressure should be reduced to below 10 mbar.

When using a turbo controller to control a gauge, all the functions are as described above except that the turbo speed is used instead of a gauge pressure. As with the gauge pressures, the turbo speed will be displayed in exponential format (eg 75% will appear as 7.5 E+1).

4.9.2 Relay control

Note : Different relays can be allocated to the same gauge channels.

The AGC has 6 internal relays that can be allocated to operate with any of the available gauge channels plus three additional settings 0, 7 and 8.

Settings 0 and 8 are used to remove a relay from a gauge channel. Setting 0 turns the relay off (de-energised), setting 8 turns the relay on (energised). Setting 7 is the fault relay setting, which is energised until a gauge error occurs on any channel when it is de-energised.

For settings 1 - 6 the operation of the relay is governed by comparing the allocated gauge channel pressure with an upper and lower pressure set point defined by the user, that is, the relay is energised when the gauge channel pressure falls below the low pressure set point and de-energised when the pressure reaches or rises above the high pressure set point.

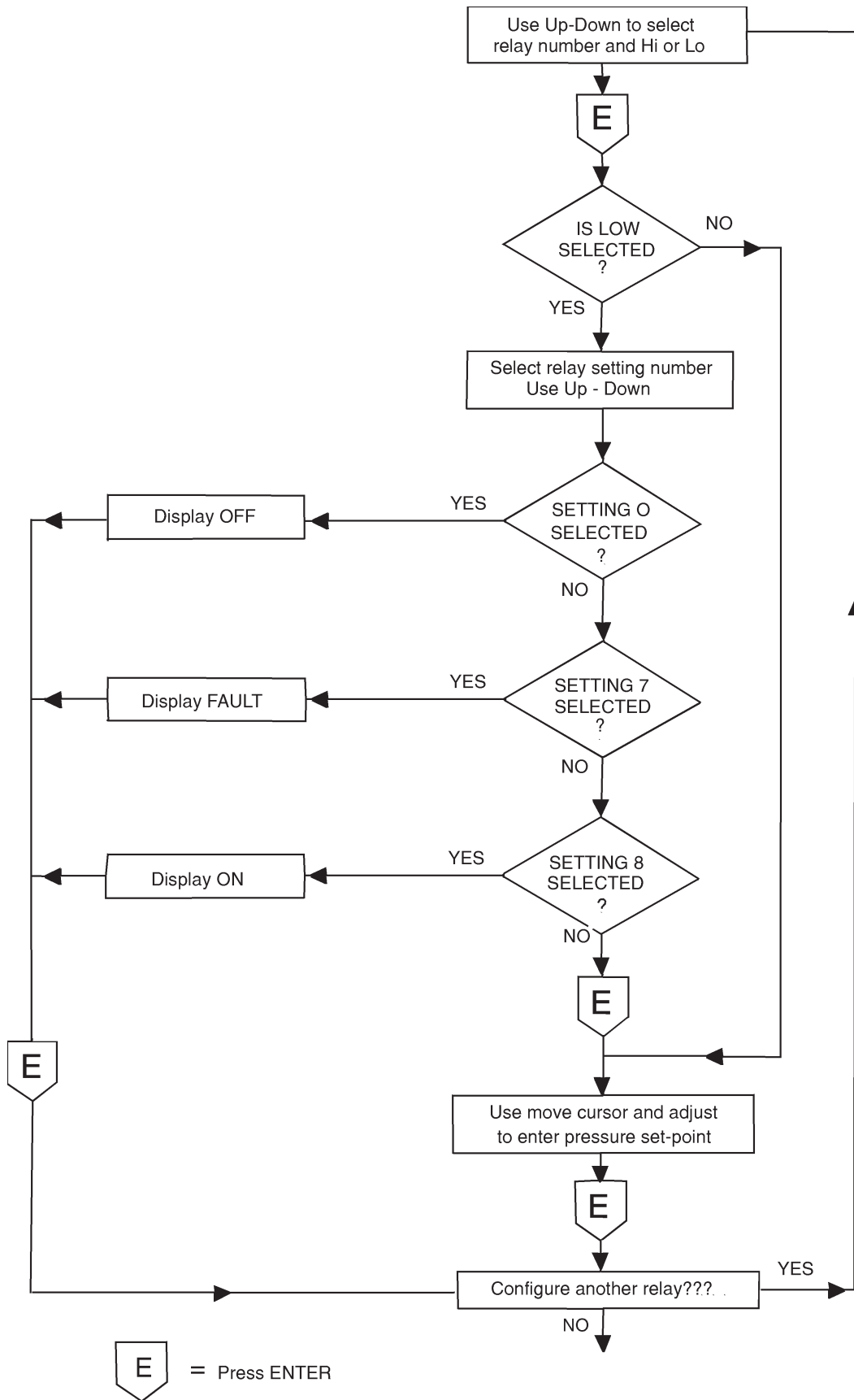

Figure 8 - Configuring the relays

The high and low settings allow the user to determine the hysteresis of the relay. If a low pressure set point is entered which exceeds the high pressure set point then the low pressure set point is ignored. In this case the relay is energised (on) when the pressure is below the high pressure set point and is de-energised (off) when the pressure is equal to or rises above it again. That is, there is no hysteresis.

The states of the relays are indicated on the front panel (see Section 4.1). The relay number is illuminated when energised. For electrical connection to the relay outputs refer to Sections 2.4.3 and 3.7.

Select RELAY in the SYSTEM menu to configure a relay. The set-point identifier number 1 will flash and Lo on the front panel will be illuminated indicating that relay 1, low pressure set point is selected. The adjustment procedure is as shown in Figure 8.

The set indicator and Hi/Lo remain illuminated during gauge channel and pressure set point adjustments.

When the gauge channel is selected the gauge identifier is displayed. OFF is displayed for setting 0, FAULT for setting 7 and ON for setting 8. If channel 0, 7 or 8 are selected then the Hi/Lo pressure set point for that relay cannot be adjusted.

Press ENTER to accept the pressure set point. Press ESCAPE to retain the previous value.

If a gauge error (see Section 4.17 and Appendix C) is detected for a gauge, then all relays allocated to that gauge will be turned off until the error has been cleared.

If any of the AGC relays have been allocated to the fault setting (setting 7), when a gauge error or major gauge error (see Section 4.17 and Appendix C) is detected for any gauge, then the relay allocated to the fault setting will be turned off.

4.9.3 Passwords

Note: If you forget the password use the master password (202) to access to the system menu and password option.

The AGC has two passwords which restrict access to areas of the menu as follows:

Name	Restricts Access To
Password 1	WRG menu APGX menu ION menu CM menu ASG menu AIGX menu TURBO menu
Password 2	SYSTEM menu

You can set and clear both passwords. If you set a password to "000" you can access the corresponding sub-menu without restriction.

A password is a three digit number entered by the “move cursor and adjust digit” method described in Section 4.7.3. Press ENTER to select a menu item, if access to the sub-menu requires a password then the display will show 000 with the first digit flashing. Press the UP/DOWN buttons to set the value of the first digit. Press CYCLE to move to the next digit and so on. Press ENTER to enter the password. Access to the sub menu will be indicated by the symbol.

To set a password, access the PASSWD sub menu. Press the UP/DOWN buttons to select PASS 1 or PASS 2 and press ENTER. Use the “move cursor and adjust digit” method to enter the password.

4.9.4 Reset

Reset permits you to reset all the settings (including passwords) back to the factory set default settings.

Select RESET from the SYSTEM menu, press ENTER, press the CYCLE button to select either DEFSET or CANCEL. Select DEFSET then press ENTER, all the settings are now returned to the factory settings. Select CANCEL then press ENTER to return to the SYSTEM menu without changing the settings.

4.9.5 Serial communications

The COMMS menu only applies to the RS232 variant. Refer to Instruction Manual D386-52-880 for detailed information on this facility.

4.9.6 Units

Pressure units can be set to one of the following in the UNITS menu.

<input type="checkbox"/> UNITS
1 MBAR 2 PASCAL 3 TORR

When ENTER is pressed UNITS is displayed followed by the number corresponding to the item selected from the list. Press the CYCLE or UP or DOWN buttons to select the required number then press ENTER. All pressure readings will now be in the selected units.

4.10 Display menu

The DISP menu allows the channel inputs to be assigned to a display line. Press UP/DOWN to select LINE 2 or LINE 3 gauge channel display option. Press ENTER. Press UP/DOWN to select a gauge channel. Press ENTER to assign.

<input type="checkbox"/> DISP
LINE 2 LINE 3

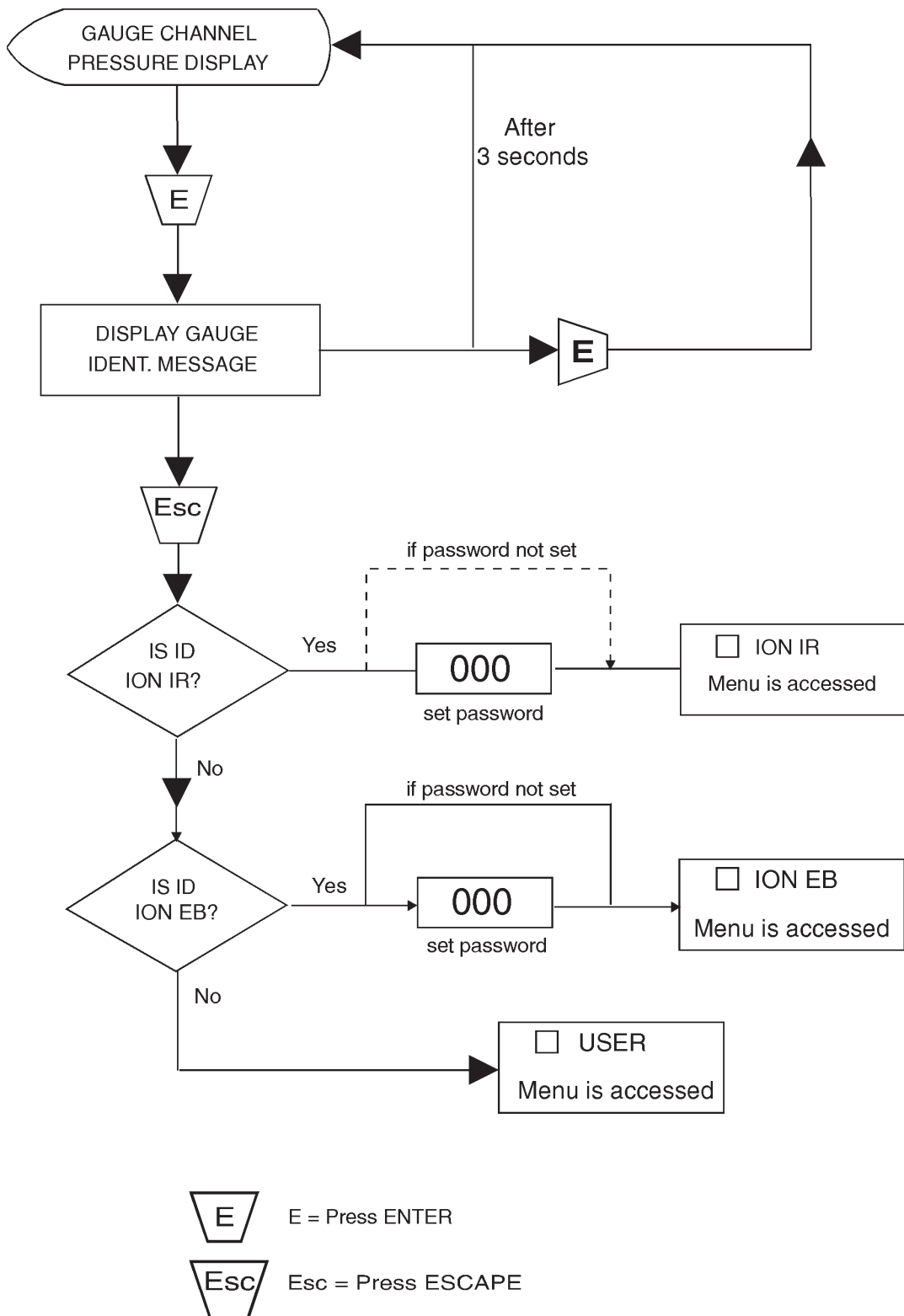

Figure 9 - Accessing the ion gauge menus

4.11 Ion Gauge Controller (IGC) menus

Access to the Ion Gauge Controller menu is gained from the appropriate gauge channel identification message as shown in Figure 9. For example if an Ion Gauge Controller is connected to channel 1, then press the UP/DOWN buttons to select channel 1 then press ENTER. The gauge identification message ION IR or ION EB will be displayed depending upon the ion gauge type. Press ESCAPE within three seconds, the display now shows ION IR or ION EB.

Access to the ION menu may be protected by password 1. Moving through the ION menu is similar to the USER menu except that the menu items show the current status of a parameter and are not fixed text messages. For example, the ION IR menu has the menu item "DG OFF" if gauge degas is off. This changes to DG ON when degas is on, or DG INH if degas is inhibited.

Possible settings are:

Item	Displayed message	Status
Emission	EM OFF EM INH EM OK EM SRT EM ERR	Emission is off Emission is inhibited Emission is on and normal Emission is starting Emission error
Degas	DG OFF DG INH DG ON	Degas is off Degas is inhibited Degas is on
Current	100 UA 1 MA 10 MA "A" Prefix	100 μ A Emission current 1 mA Emission current 10 mA Emission current AUTO Emission mode
Head	HEAD A HEAD B	Gauge Head A selected Gauge Head B selected
Filament	FIL 1 FIL 2	Filament 1 selected Filament 2 selected
Sensitivity	SENXX.X	Ion gauge sensitivity factor setting. XX.X is a value between 2 and 30
Auto Restrike	RSTRK 0 RSTRK 1	Auto Restrike is off Auto Restrike is on

Press ENTER or CYCLE to adjust the status of a displayed item. Press ENTER to access the emission sub-menu and to allow the sensitivity to be adjusted, press CYCLE to cycle the status of the item. Press the CYCLE button to cycle the settings of the following items:

Item	cycle
EMISSION	ON and OFF
DEGAS	ON and OFF
HEAD	A and B
FILAMENT	1 and 2
RESTRIKE	0 and 1

4.11.1 Ion gauge sensitivity factor

Note: The sensitivity factor set from the AGC overrides the sensitivity constant set in the ion gauge controller (refer to ion gauge operating instructions).

Each ion gauge head has an associated ion gauge sensitivity factor dependent upon its geometry. The factor is a measure of the ratio of head current output to current input (emission current) for a given pressure. The gauge sensitivity factor can be viewed or set from the ION menu. The units are per the current units setting. Enter the ION menu and press the UP/DOWN buttons to move to the SENXX.X item. XX.X is the current sensitivity factor setting (a number between 2 and 30). Press ENTER and press the UP/DOWN and CYCLE buttons to adjust the value using the “move cursor and adjust” method (see Section 4.7.3). Press ENTER to return to SENXX.X. If a number less than 2.0 is entered then the setting defaults to 2.0, similarly, for a number greater than 30.0 the setting defaults to 30.0 after pressing ENTER. (If Pascal is selected the units are 100 times smaller, thus the decimal point will be two places to the left).

4.11.2 Ion gauge emission current

Note: A consequence of this may be a small change in pressure reading as the emission current changes and consequently there is a small change in gauge tube sensitivity and rate of outgassing.

The ion gauge filament emission current can be viewed and set from the ION menu. Press the UP/DOWN buttons to move to the emission current item, the display will show the present setting, for example, 100 UA for 100 μ A. Press ENTER, EMIS is displayed, press the UP/DOWN buttons to select one of four settings in the sub menu list press ENTER. Available settings are:

<input type="checkbox"/> EMIS
AUTO 100 UA 1 MA 10 MA

The accuracy of the gauge can be optimised by selecting the filament emission current most suited to the operating pressure range as shown in the following table:

Ion gauge pressure mBar	Emission current	Menu selection
>1E-4	100 μ A	100 UA
1E-8 to 1E-4	1 mA	1 MA
<1E-8	10 mA	10 MA

If AUTO is selected, then the AGC will automatically set the filament emission current based on the gauge pressure. In this mode the gauge pressure is constantly monitored and the emission current selected in accordance with the above table.

When in AUTO mode the emission current setting in the ION menu is shown prefixed by an A, for example, if the setting was 10 mA in AUTO mode then the display would show A10 MA.

4.11.3 Ion gauge degas

Note: Degassing an ion gauge head above a pressure of 1E-6 mbar may shorten the life of the gauge head.

After an ion gauge head has been at atmospheric pressure for some time (for example, during transit) or if the filament has become contaminated it will be necessary to degas the head at a pressure below 1E-6 mbar for a period of approximately 30 minutes to bake off these contaminants.

Select the degas item from the ION menu to degas an ion gauge. Press the CYCLE button to cycle degas on or off. Degas turn on is inhibited when the gauge pressure is above 1E-4 mbar (7.5 E-5 torr), or when there is an emission error. This is indicated by the message DG INH. During degassing the ion gauge pressure is still valid, but at a greatly reduced accuracy since the gauge sensitivity factor is significantly reduced during the process. The E is replaced by d on the pressure indication during degas.

4.11.4 Qualification gauge

An additional active gauge head can be connected to the active ion gauge controller for use as a qualifying gauge. The active gauge internal set point is used to enable ion gauge turn on or off. In addition, any of the gauges connected to the AGC can be used to qualify ion gauge turn on or off (see Section 4.9.1).

When the qualifying gauge is fitted and its pressure reading is higher than its internal set point (set point off) then ion gauge emission is inhibited from the active controller and the error message OFF is displayed instead of the channel pressure. When the set point trips on, the filament emission turn on or off is enabled.

4.11.5 Auto Restrike

When the ION gauge is switched ON (EMISSION is ON), and reading pressure normally, it is possible for an error condition to cause emission to be switched off. This can happen due to a pressure surge, causing the pressure to be out of the range of the ION gauge. The AGC recognises that the gauge has lost emission and displays EM ERR. The gauge then needs to be switched on again manually, as the ION gauge controller will enter a latched lockout condition, which needs to be reset by the AGC.

When this feature is enabled, the AGC automatically attempts to clear the latched state in the ION gauge controller and re-start the ION gauge.

4.12 Active strain gauge control

Edwards Active Strain Gauges have a linear pressure characteristic and output voltage signal directly proportional to the pressure. The output is 0 to 10 V d.c. over the gauge pressure range. Full scale output can be as high as 26 V d.c. when the gauges are overrange. At pressures below the gauge operating range the signal output can be negative (as low as -200 mV) indicating that either the gauge head or AGC requires zeroing. (Refer to Section 4.12.2).

4.12.1 ASG RANGE menu

It is important that the channel is configured to match the connected Active Strain Gauge type, otherwise erroneous pressure readings will occur.

If a new ASG gauge is detected, the message NEW ID is displayed. This will be flashing if a triple display is fitted to the AGC. Press the ENTER button until the RANGE menu is displayed. Use the "select and enter" method to select the appropriate gauge range value.

4.12.2 ASG menu (See Appendix A3)

The ASG menu is accessed directly from the gauge channel as follows:

Select gauge channel and press ENTER to display the gauge identification “ASG” then press ESCAPE within three seconds. This allows access to the ASG menu, the display shows ASG or -000— if the channel is password protected. If password 1 has been set then its value must be entered.

Press the UP/DOWN and ENTER buttons to access FORMAT or SGZERO.

<input type="checkbox"/> ASG
FORMAT SGZERO

FORMAT

This is cycled between FIXED and FLOAT - using the CYCLE button.

FIXED displays the channel pressure with a fixed number of decimal places. FLOAT -displays the pressure in scientific format, that is, mantissa and exponent. The displayed resolution depends on the selected range from the RANGE menu.

Range	Gauge sensitivity Volts per mbar or per torr	Display resolution FIXED mode mbar or torr
2000	0.005	0.1
1000	0.01	0.1
200	0.05	0.01

SGZERO

Active Strain Gauge channel zeroing menu contains the following:

<input type="checkbox"/> SGZERO
ON/OFF ZERO

The output of the Active Strain Gauge is zero volts at a pressure below its operating range. It is quite normal to observe a small amount of drift in this zero pressure reading. The AGC can accommodate positive and negative zero shifts in the gauge output by subtracting the zero reading from the normal voltage output of the gauge.

Press the UP/DOWN buttons to select ON or OFF to enable or disable ZERO function. Press the ENTER button. Press the CYCLE button to cycle between ON and OFF.

To perform the ZEROING function, press the UP/DOWN buttons to select ZERO, press the ENTER button and press the CYCLE button to select CANCEL or DOZERO. CANCEL aborts the operation leaving the zero voltage unchanged, DOZERO stores the current gauge voltages as the zero voltage (that is, before selecting DOZERO the gauge should be evacuated below its measurement limit). Further zero adjustment and calibration is available at the gauge head, refer to the gauge operating instructions.

4.13 Capacitance manometer control

CAUTION

The correct electrical supplies for the Barocel 600 series are only available from inputs 4, 5 and 6 on the CM VER types of AGC. If you connect a Barocel 600 series to any other input you may damage the Barocel. Check that you have the correct type of AGC before you connect a Barocel 600 series.

Note: See Section 2.4.6 for maximum permissible load on the AGC.

The AGC is compatible with most types of capacitance manometers. Capacitance manometers requiring a bipolar power supply can be used only with the CM VER types of AGC. The following Edwards capacitance manometers can be used with the AGC:

Gauge type	Supply	Gauge channel compatibility
600	Bipolar ± 15 V d.c.	Inputs 4, 5 and 6 of CM VER units only
622	Bipolar ± 15 V d.c.	Inputs 4, 5 and 6 of CM VER units only
655	Bipolar ± 15 V d.c.	Inputs 4, 5 and 6 of CM VER units only
590	Single 18 to 35 V d.c.	All AGC channels

Compatible Edwards capacitance manometers have a linear pressure characteristic and output voltage signal directly proportional to the pressure. The output is 0 to 10 V d.c. over the gauge pressure range. Full scale output is 12 to 13 V d.c. when the gauges are overrange. At pressures below the gauge operating range the signal output can be negative (as low as -200 mV) indicating that either the gauge head or AGC requires zeroing.
(Refer to Section 4.13.2).

4.13.1 CM RANGE menu

It is important that the channel is configured to match the connected capacitance manometer type, otherwise erroneous pressure readings will occur.

If a new CM gauge is detected, the message NEW ID is displayed. This will be flashing if a triple display is fitted to the AGC. Press the ENTER button until the RANGE menu is displayed. Use the "select and enter" method to select the appropriate gauge range value and then use the "CYCLE and ENTER" to select the gauge units (MBAR or TORR).

4.13.2 CAPMAN menu (See Appendix A4)

The CAPMAN menu is accessed directly from the gauge channel as follows:

Select gauge channel and press ENTER to display the gauge identification 590 CM or 600 CM then press ESCAPE within three seconds. This allows access to the CAPMAN menu, the display shows CAPMAN or 000 if the channel is password protected. If password 1 has been set then its value must be entered.

Press the UP/DOWN and ENTER buttons to access FORMAT or CMZERO.

<input type="checkbox"/> CAPMAN
FORMAT CM ZERO

FORMAT

This is cycled between FIXED and FLOAT using the CYCLE button.

FIXED displays the channel pressure with a fixed number of decimal places. FLOAT displays the pressure in scientific format, that is, mantissa and exponent. The displayed resolution depends on the selected range from the RANGE menu.

Range	Gauge sensitivity Volts per mbar or per torr	Display resolution FIXED mode mbar or torr
2000	0.005	0.1
1000	0.01	0.1
200	0.05	0.01
100	0.10	0.01
20	0.5	0.001
10	1.00	0.001
2	5.0	0.0001
1	10.00	0.0001
0.2	50.00	0.00001
0.1	100.00	0.00001
0.05	200.00	0.00001

CMZERO

Capacitance manometer channel zeroing menu contains the following:

<input type="checkbox"/> CMZERO
ON/OFF ZERO

The output of a capacitance manometer is zero volts at a pressure below its operating range. It is quite normal to observe a small amount of drift in this zero pressure reading. The AGC can accommodate positive and negative zero shifts in the gauge output by subtracting the zero reading from the normal voltage output of the gauge.

Press the UP/DOWN buttons to select ON or OFF to enable or disable CM-ZERO function. Press the ENTER button. Press the CYCLE button to cycle between ON and OFF.

To perform the ZEROING function, press the UP/DOWN buttons to select ZERO, press the ENTER button and press the CYCLE button to select CANCEL or DOZERO. CANCEL aborts the operation leaving the zero voltage unchanged, DOZERO stores the current gauge voltages as the zero voltage (that is, before selecting DOZERO the gauge should be evacuated below its measurement limit). Further zero adjustment and calibration is available at the gauge head, refer to the gauge operating instructions.

4.14 Wide range gauge control

The Wide Range Gauge is a combined pirani and inverted magnetron gauge in a single unit. The pirani gauge measures pressure from atmosphere down to 10^{-3} mbar while the inverted magnetron measures from 10^{-2} mbar down to 10^{-9} mbar. Outputs from both sensors are used to determine pressures between 10^{-2} and 10^{-3} mbar.

The WRG will automatically perform a pirani sensor vacuum setting every time it is pumped down to a pressure lower than 10^{-4} mbar.

Note: If the pirani sensor is replaced (see WRG instruction manual D147-01-880) it may initially fail to indicate a pressure of less than 10^{-3} mbar. To correctly calibrate the pirani it should be pumped down to a pressure of 10^{-5} mbar or below before performing the CAL operation found in the WRG menu.

Adjustment of the atmosphere setting can be performed using the WRG menu (see Appendix A5).

Note: Atmosphere adjustment of the WRG should be performed after it has been allowed to operate at atmospheric pressure for at least 10 minutes.

Manual adjustment of the gauge is available at the gauge head (see WRG instruction manual (D147-01-880)).

4.14.1 WRG menu (See Appendix A5)

The WRG menu is accessed directly from the gauge channel as follows:

Select gauge channel and press ENTER to display the gauge identification “WRG” then press ESCAPE within three seconds. This allows access to the WRG menu, the display shows WRG or -000— if the channel is password protected. If password 1 has been set then its value must be entered.

Press the UP/DOWN and ENTER buttons to access CAL.

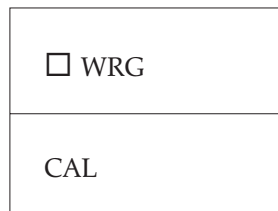

CAL

The CAL function is cycled between CANCEL and DO CAL - using the CYCLE button.

Selecting CANCEL by using the ENTER button returns the AGC to the WRG menu. Selecting DO CAL instructs the WRG to perform the atmosphere adjustment (or the vacuum adjustment if it detects that the gauge is under vacuum).

4.15 Turbo control

A link can be made between the AGC and any of the Edwards EXC turbo controllers (refer to Section 3.5) which allows the AGC to control the turbo pump (and depending on EXC version, the backing pump as well) and for the turbo pump speed to be used by the AGC to control gauges and relays. If the AGC has an RS232 port then this link also allows the turbo pump to be controlled via RS232 (refer to AGC RS232 option supplementary instructions D386-52-880).

When the EXC is connected NEW ID will be displayed and should be accepted in the same way as other gauges. The turbo channel will show OFF in the same way as an AIM or ION gauge and can be turned on and off using the cycle key  in the same way as an AIM or ION gauge (for this function to work with an EXC120 or EXC300 the start/stop button on the front of the EXC must be locked on). Turning the turbo on will start the turbo pump (and where an EXC120 or EXC300 is used with a backing pump connected, the backing pump will also start) and the AGC display will show the turbo pump rotational speed in % of full speed.

The turbo pump speed may be used to control relays or other gauges in the same way as a gauge pressure (refer to sections 4.9.1 and 4.9.2). The auto control feature can also be used to switch on the turbo pump when a gauge pressure reaches a certain level. If this feature is used with an EXC100 turbo controller then pressing the cycle key will cycle the turbo display between OFF and the turbo speed but will not turn the turbo on and off; the turbo will be turned on and off by the controlling gauge. If this feature is used with an EXC120 or EXC300 then pressing the cycle key will switch on the backing pump if one is connected and switch the display from OFF to the turbo pump speed but the turbo pump will only be switched on when the controlling gauge switch point is reached.

4.15.1 TURBO menu (See Appendix A6)

It may be required to lock the turbo pump on at the AGC and to control it from the EXC if you are using an EXC120 or EXC300. This can be done using the TURBO menu.

The TURBO menu is accessed directly from the gauge channel as follows:

Select gauge channel and press ENTER to display the gauge identification "TURBO" then press ESCAPE within 3 seconds. This allows access to the TURBO menu, the display shows TURBO or 000 if the channel is password protected. If password 1 has been set then its value must be entered.

Press the UP/DOWN and ENTER buttons to access LOCKx.

<input type="checkbox"/> TURBO
LOCKx

LOCKx

The state of x is cycled between 0 (unlocked) and 1 (locked) using the CYCLE button.

If auto control has been set up to control the turbo pump with a gauge then locking the turbo pump on at the AGC will pass control of the backing pump to the EXC (start/stop button) but the turbo pump will continue to be controlled by the gauge. If this is not what is required then the auto control should be turned off.

4.16 Active linear pirani gauge (APGX) control

The APGX-L and APGX-M gauges are Linear Pirani gauges which cover the pressure range from atmosphere to 10^{-4} or 10^{-3} mbar. The APGX-H is a convection-enhanced Pirani gauge which covers the range from atmosphere to 10^{-4} mbar, with improved accuracy above 100 mbar. The vacuum and atmosphere setting of the gauges can be performed using the APGX menu.

Note: Setting of the gauge should be performed after allowing it to stabilise for at least 10 minutes.

Manual adjustment of the gauge is available at the gauge head.

4.16.1 APGX menu (see Appendix A7)

The APGX menu is accessed directly from the gauge channel as follows:

Select gauge channel and press ENTER to display the gauge identification "APGX" then press ESCAPE within three seconds. This allows access to the APGX menu, the display shows APGX or -000- if the channel is password protected. If password 1 has been set then its value must be entered.

Press the UP/DOWN and ENTER buttons to access CAL.

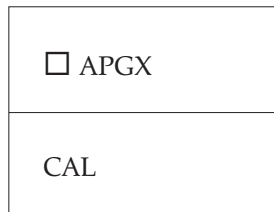

CAL

The CAL function is cycled between CANCEL and DO CAL - using the CYCLE button. Selecting CANCEL by using the ENTER button returns the AGC to the APGX menu. Selecting DO CAL instructs the APGX to perform atmosphere and vacuum calibration.

4.17 Active Ion Gauge (AIGX)

The Active Ion Gauge is a miniature ion gauge consisting of an all metal tube with two yttria coated iridium filaments, and a detachable housing containing drive and signal processing electronics. The gauge covers the measurement range 6.6×10^{-10} to 6.6×10^{-2} mbar (5×10^{-10} to 5×10^{-2} torr).

The emission current is controlled by the gauge electronics, and switches automatically between 1 mA and 100 μ A at a pressure of approximately 5×10^{-3} mbar. The gauge sensitivity is pre-set during manufacture to ensure accurate pressure indication, and is not adjustable. Selection between filament 1 and filament 2 is by a slide switch mounted on top of the gauge. Refer to the AIGX instruction manual D048-50-880 for further details.

The AIGX can be turned on and off using the CYCLE button. When the gauge is turned on, IGENIS is displayed momentarily before the pressure reading (typically 5 seconds). This message indicates that emission is being stabilised. If any errors occur then the appropriate error message will be displayed.

The degas function of the AIGX is accessible through the AIGX menu.

4.17.1 AIGX menu (See Appendix A8)

The AIGX menu is accessed directly from the gauge channel as follows:

Select gauge channel and press ENTER to display the gauge identification "AIGX" then press ESCAPE within three seconds. This allows access to the AIGX menu, the display shows AIGX or -000- if the channel is password protected. If password 1 has been set then it's value must be entered. Press the UP/DOWN buttons to access the degas item. Press the CYCLE button to cycle DEGAS OFF or DEGAS ON.

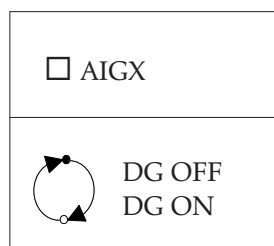

The degas operation is recommended whenever a new AIGX is used, or when it has been exposed to atmosphere. Degas the gauge when the pressure has fallen below 10^{-5} mbar. The gauge is internally protected from degassing at high pressure (above 10^{-4} mbar).

During degas the pressure reading is available, but at reduced accuracy. The display will change to show 'd' instead of 'E', indicating that degas is active. The duration of the degas is set at three minutes, after which the gauge will return to normal pressure reading and the display will show 'E'.

4.18 Memory back up

The controller has a memory back-up system which ensures that all parameters set up by the operator are retained in memory when the unit is switched off.

4.19 Error handling

When an error occurs it is displayed but does not interrupt the operation of the AGC (except for automatic gauge control and relay operation, see Sections 4.9.1 and 4.9.2). Errors are displayed in two formats, a text message such as NEW ID or an error number such as ERR 22. A complete list of errors and faults appears in Appendix C.

Press ENTER to clear errors, except for self clearing errors which are displayed momentarily (for example, SRKING which is visible while an AIM gauge is attempting to strike and disappears after striking is completed). Press CYCLE to clear a gauge error (repeat for multiple errors).

5 MAINTENANCE

WARNING

There are high voltages in the AGC when the electrical supply is switched on. You must obey all standard procedures for the safe handling of electricity. Servicing should only be carried out by qualified personnel.

CAUTION

Do not attempt repair or re-calibration of the controller, there are no user serviceable parts.

5.1 Fuse replacement

The electrical supply fuse holder is an integral part of the IEC type electrical supply socket assembly. Pull out the end section which forms the fuse holder, replace the fuse with a 2 A type T, slow blow.

6 STORAGE AND DISPOSAL

6.1 Storage

1. Return the AGC to its protective packaging.
2. Store in a cool dry place.

6.2 Disposal

Dispose of the AGC in accordance with local and national safety and environmental requirements.

Alternatively, you may be able to recycle the AGC and/or cables; contact BOC Edwards or your supplier for advice (also see below).

The AGC and associated cables are within the scope of the European Directive on Waste Electrical and Electronic Equipment, 2002/96/EC. From August 2005, BOC Edwards will offer European customers a recycling service for the AGC/cables at the end of the product's life. Contact BOC Edwards for advice on how to return the AGC/cables for recycling.

7 SPARES AND ACCESSORIES

7.1 Introduction

Edwards products, spares and accessories are available from Edwards companies in Belgium, Brazil, Canada, France, Germany, Great Britain, Hong Kong, Italy, Japan, Korea, Switzerland, U.S.A, and a world wide network of distributors. The majority of these centres employ Service Engineers who have undergone comprehensive Edwards training courses.

Order spare parts and accessories from your nearest Edwards company or distributor. When ordering, please state for each part required:

- Model and Item Number of your equipment
- Serial number (if any)
- Item Number and description of part

7.2 Relay expansion board kit

A relay board is available as an accessory which can be fitted to all versions of the AGC. The board fits inside the case of the AGC, refer to Section 2.4.4 for technical data.

Relay expansion board kit	D386-51-800
---------------------------	-------------

7.3 Cables

IEC Electrical supply cable

2m (6 feet), free end	D400-13-020
2m (6 feet), including plug (UK)	D400-13-025
2m (6 feet), including plug (N.Europe)	D400-13-030
2m (6 feet), including plug (USA)	D400-13-120

Active gauge cables

0.5m	18 inches	D400-01-005
1m	3 feet	D400-01-010
3m	10 feet	D400-01-030
5m	15 feet	D400-01-050
10m	30 feet	D400-01-100
15m	50 feet	D400-01-150
25m	80 feet	D400-01-250
50m	150 feet	D400-01-500
100m	325 feet	D400-01-999

RS232 cable

3m (10 feet)	D386-50-400 (25 way "D" Type)
3m (10 feet)	D386-50-500 (9 way "D" Type)

Adapter cables (used in conjunction with Active gauge cables)

600 series	0.5 m (18 inches)	D400-03-010
590 series	0.5 m (18 inches)	D400-03-020
622 series	0.5 m (18 inches)	D400-03-030
655 series	0.5 m (18 inches)	D400-03-050
ASG	0.5 m (18 inches)	D400-03-060
EXC100	0.5 m (18 inches)	D400-03-070
EXC120	0.5 m (18 inches)	D400-03-080
EXC300	0.5 m (18 inches)	D400-03-090

7.4 Active gauges

Compatible Edwards active gauges include:

Wide Range Gauge
Active Pirani Gauge
Active Inverted Magnetron Gauge
Active Thermocouple Gauge
Active Ion Gauge
Active Strain Gauge

A number of variants of each gauge type is available. Refer to BOCE Catalogue for a more comprehensive list.

7.5 Capacitance manometer

Barocel
Type 600
Type 622
Type 655
Type 590

Refer to BOCE Catalogue for details.

7.6 Turbo controllers

Refer to BOCE Catalogue for details of turbo pump and controller range.

APPENDIX A

System menus

There are five types of box used in the menu tree listings as follows:

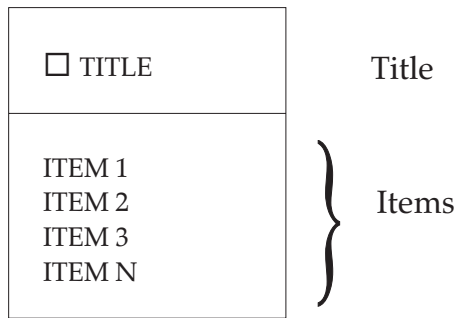

1 Menu

2 Cycle box

Use  button to toggle between state A and state B

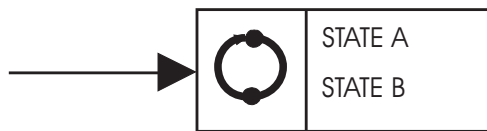

3 Show box

After pressing ENTER a value or message is displayed, the show box contains all the possible messages but only one of them is displayed as appropriate.

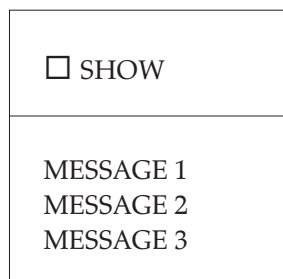

4 Select box

Use UP / DOWN buttons to select a gauge channel or relay.

<input type="checkbox"/> SELECT
Gauge channel

5 Adjust box

The abbreviation for move cursor and adjust mode.

The number of digits or characters to adjust are shown as square.

<input type="checkbox"/> ADJUST
<input type="checkbox"/> <input type="checkbox"/> <input type="checkbox"/>

A1 USER MENU

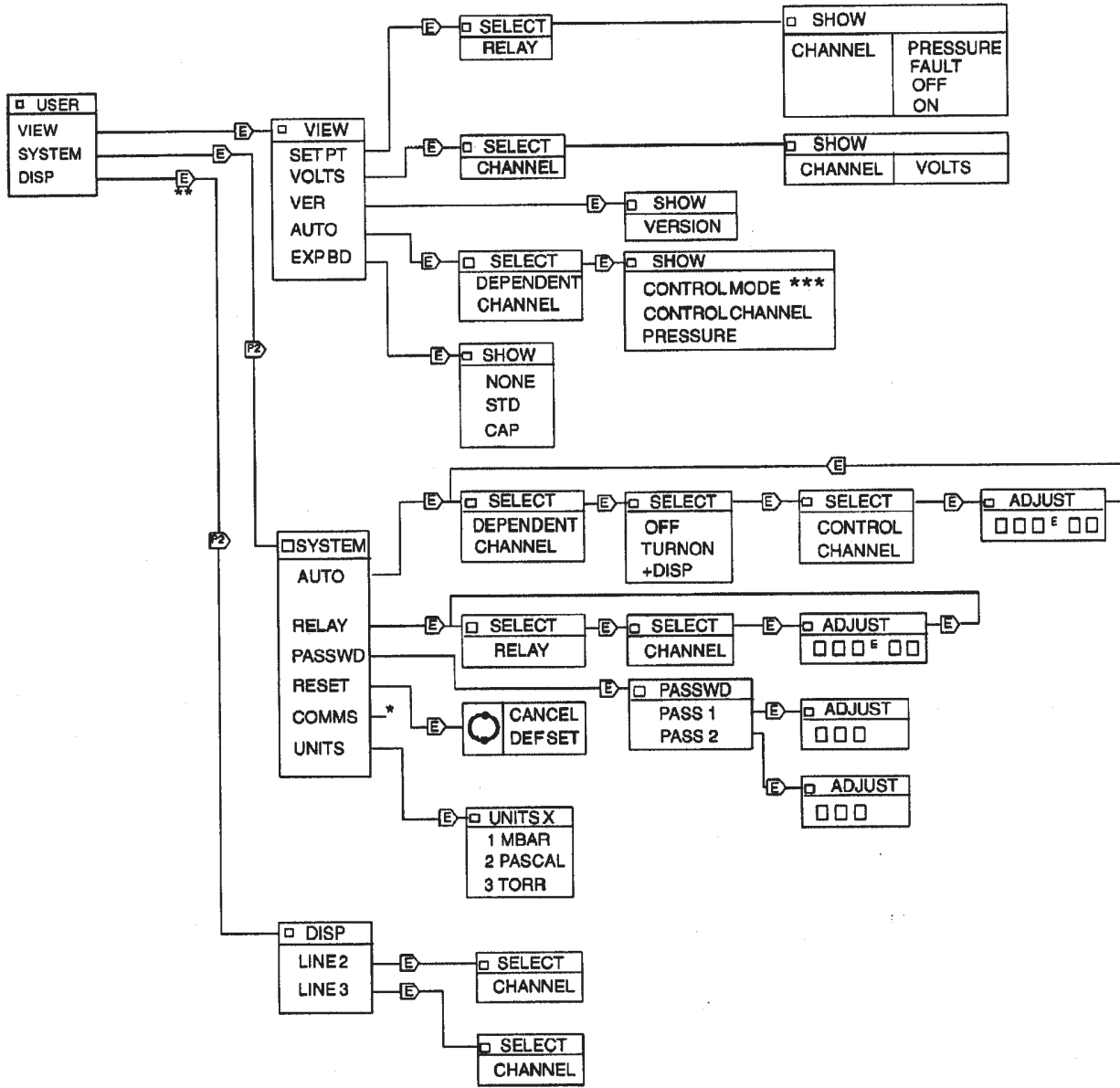

- E** = Press ENTER
- P** = Enter PASSWORD
- *** = RS232 Menu (refer to D386-52-880)
- **** = Triple display option only
- ***** = 0, 1, 2

User Menu

A2 ION GAUGE CONTROLLER MENU

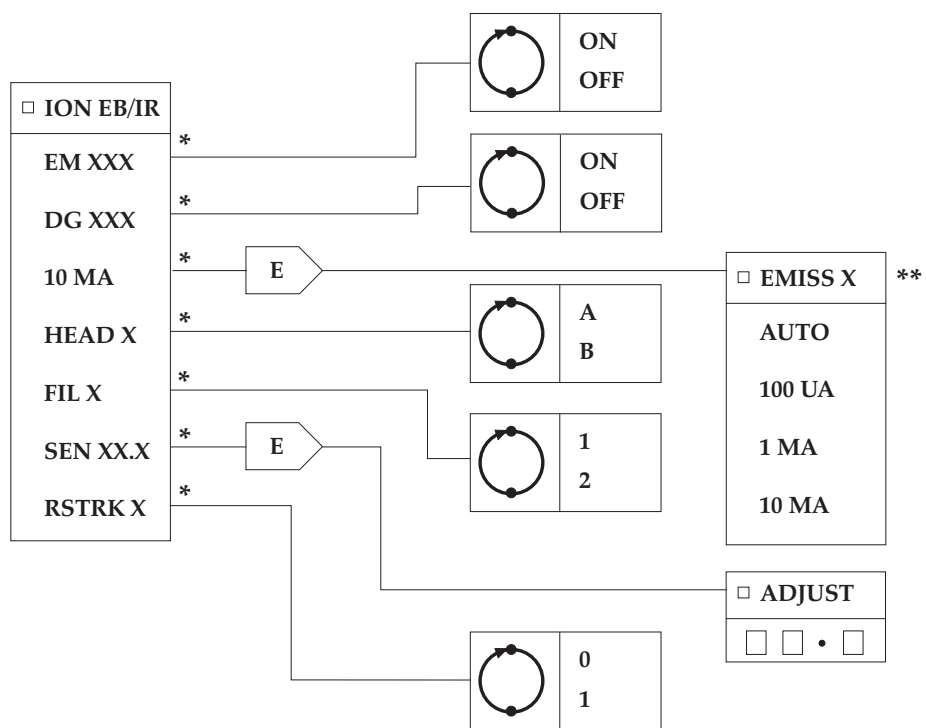

E = PRESS ENTER

** X = 0, 1, 2 OR 3

* refer to Section 4.12 for possible settings.

Ion Gauge Menu

A3 ASG MENU

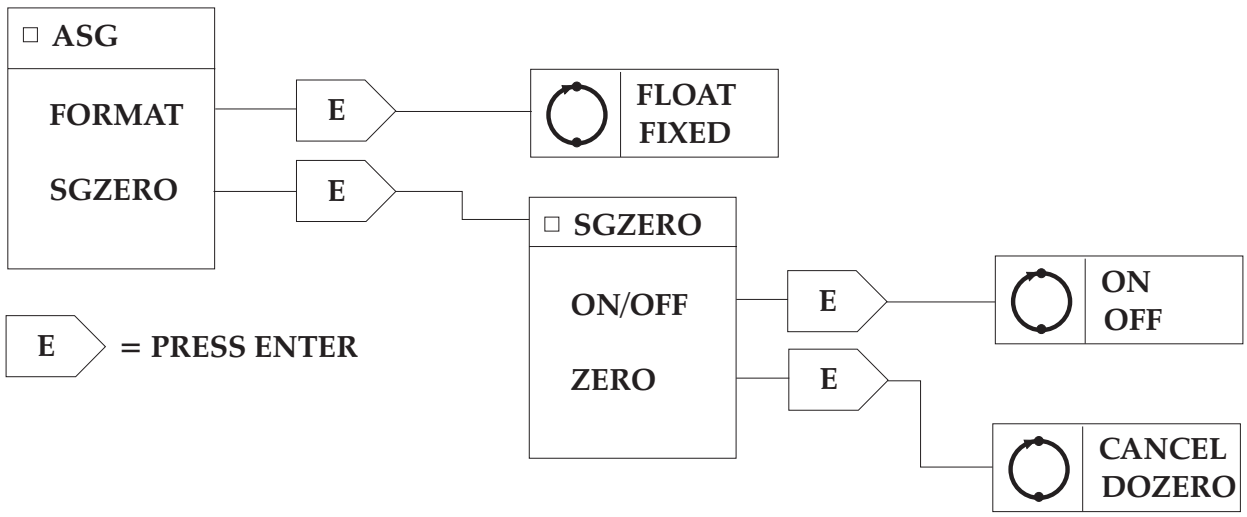

ASG Menu

A4 CAPMAN MENU

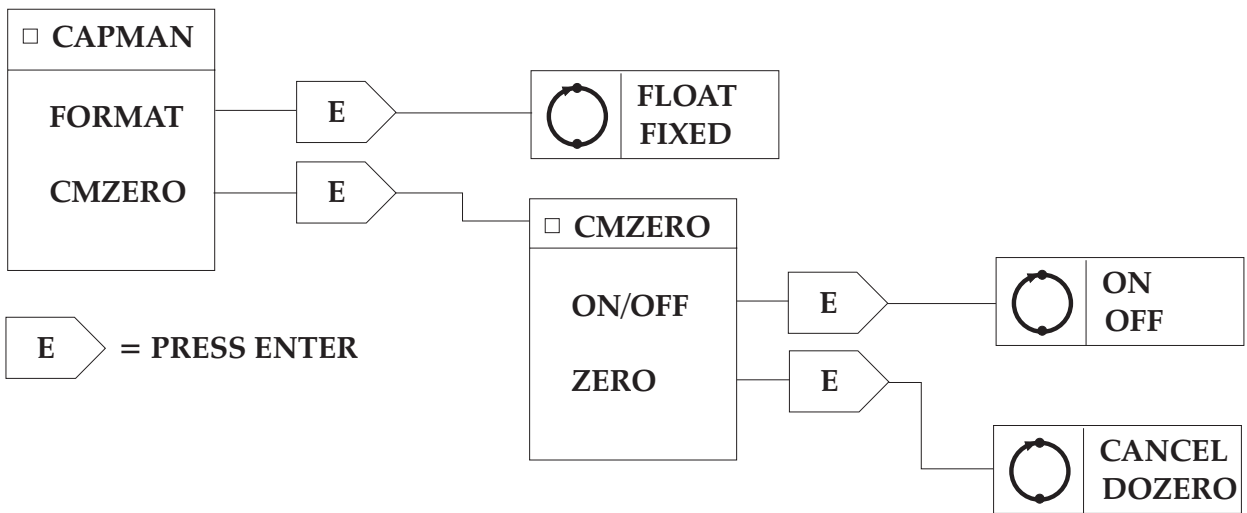

CAPMAN Menu

A5 WRG MENU

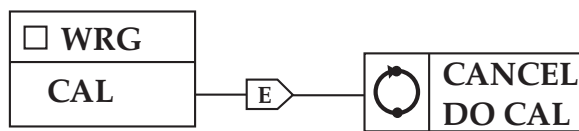

 = PRESS ENTER

WRG Menu

A6 TURBO MENU



TURBO Menu

A7 APGX MENU

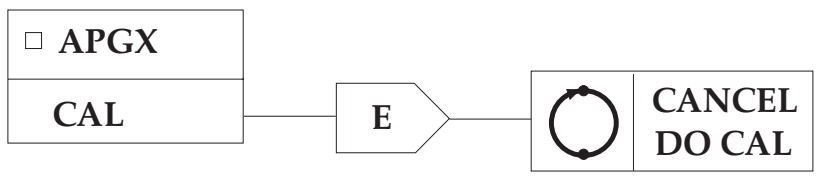

 = PRESS ENTER

APGX Menu

A8 AIGX MENU



APPENDIX B

Default settings

All locations and variables are set to zero except for the following:

Parameter	Default setting
Auto turn on pressures	1.00E-3
Relay pressures Hi / Lo	1.00E+0
Ion gauge constants	10.0
Ion gauge emission current	AUTO
Ion gauge head	A
Ion gauge filament	1
Auto control channels	OFF
Pressure units	mbar
Passwords 1 and 2	disabled
Serial Port	9600 baud (User) 300 baud (Factory) 1 stop bit no parity
Display line 1	Gauge Channel 1
Display line 2	Gauge Channel 2
Display line 3	Gauge Channel 3

APPENDIX C

Active gauge controller errors

C1 Major errors

These override the display as ERR XX where XX is the error number, clear by pressing ENTER.

Error No.	Fault	Action
00	Gross system fault	Contact BOCE
10	Cannot initialise display	Contact BOCE
11	Cannot initialise keyboard e.g. button stuck down	Contact BOCE
12	Cannot initialise RS232 port	Contact BOCE
16	Corrupted internal memory. Resets to default values	If fault re-occurs, contact BOCE
17	Cannot initialise relay board	Contact BOCE
20	Gauge output voltage negative e.g. Capacitance Manometer or ASG	Check gauge zero in accordance with gauge working instructions
20	Current source out of adjustment	Contact BOCE
21	Cannot detect mains frequency. Unit defaults to 50Hz.	Check electrical supply for noise
22	Voltage reference error. Internal reference voltage is out of range. Analogue to digital converter not running correctly	Contact BOCE
23	Expansion board identification error.	Contact BOCE
25	E ² PROM Read error	If fault re-occurs, contact BOCE
26	E ² PROM Writer error Parameter settings will not be saved when power is turned off.	

C2 Major gauge errors

These are displayed as a text message, clear by pressing ENTER.

ERROR MESSAGE	REASON
NEW ID	New gauge identification in channel.
ID ERR	Gauge identification error.
? ADC	Analogue to digital converter problem.
SW ERR	Faulty gauge connection.
CAP ??	Capacitance manometer Type 600 fitted in wrong socket.
DIV 0	System error. Contact BOCE.

C3 Gauge errors

These are displayed as text messages, preceded by the gauge channel, clear by pressing CYCLE.

ERROR MESSAGE	REASON
EM ERR	An Ion gauge emission timed out after 10 seconds. Gauge filament is turned off (see IGEMIS).
OVER R	AIGX over pressure.
FAULT	Gauge voltage out of range.
NOTSRK	An AIM gauge has failed to strike within 15 minutes (see SRKING)
?VOLTS	Gauge voltage under range.
ERR A	WRG pirani failure.
ERR B	WRG Inverted Magnetron short circuit.
ERR C	WRG striker filament broken.
ERR D	WRG Inverted Magnetron not struck.
ERR E	APGX filament broken.
ERR F	APGX calibration error.
NOTUBE	APGX-H tube not fitted.

C4 Warning messages

These are displayed as a text message and are self clearing.

ERROR MESSAGE	REASON
IG EMIS	Ion gauge filament is NOT OK but the unit has not reached the 10 second time out.
OFF	Indicates that an AIM or ION gauge is OFF. The gauge can be turned on manually by pressing the CYCLE button. If automatic gauge control has been configured, the gauge will be turned on automatically by the controlling gauge. If the gauge cannot be turned on, check the automatic gauge control setting (see Section 4.9.1).
SRKING	AIM gauge has NOT struck. Unit will turn gauge OFF if it fails to strike within 15 minutes.
???	Gauge channel was empty before or after a gauge identification change. Associated with NEW ID. i.e. Gauge identification unknown.
AC ERR	The auto-controlling gauge is in error.
IG INH	Ion gauge turn on is inhibited. The ion gauge controller qualification gauge is inhibiting turn on or the ion gauge controller is turned off at the mains.
??? ID	The gauge cannot be identified. This message will also be displayed if automatic gauge control is configured, and the controlling gauge is disconnected.

Return of BOC Edwards Equipment - Procedure

INTRODUCTION

Before returning your equipment, you must warn BOC Edwards if substances you used (and produced) in the equipment can be hazardous. This information is fundamental to the safety of our Service Centre employees and will determine the procedures employed to service your equipment.

Complete the Declaration (HS2) and send it to BOC Edwards before you dispatch the equipment. It is important to note that this declaration is for BOC Edwards internal use only, and has no relationship to local, national or international transportation safety or environmental requirements. As the person offering the equipment for shipment, it is your responsibility to ensure compliance with applicable laws.

GUIDELINES

- Equipment is '**uncontaminated**' if it has not been used, or if it has only been used with substances that are not hazardous. Your equipment is '**contaminated**' if it has been used with any substances classified as hazardous under EU Directive 67/548/EEC (as amended) or OSHA Occupational Safety (29 CFR 1910).
- If your equipment has been used with radioactive substances, biological or infectious agents, mercury, polychlorinated biphenyls (PCB's), dioxins or sodium azide, you must decontaminate it before you return it to BOC Edwards. You must send independent proof of decontamination (for example a certificate of analysis) to BOC Edwards with the Declaration (HS2). Phone BOC Edwards for advice.
- If your equipment is contaminated, you must either:
 - Remove all traces of contamination (to the satisfaction of laws governing the transportation of dangerous/hazardous substances).
 - Or, properly classify the hazard, mark, manifest and ship the equipment in accordance with applicable laws governing the shipment of hazardous materials.

Note: Some contaminated equipment may not be suitable for airfreight.

PROCEDURE

1. Contact BOC Edwards and obtain a Return Authorisation Number for your equipment.
2. Complete the Return of BOC Edwards Equipment - Declaration (HS2).
3. If the equipment is contaminated, you must contact your transporter to ensure that you properly classify the hazard, mark, manifest and ship the equipment, in accordance with applicable laws governing the shipment of contaminated/hazardous materials. As the person offering the equipment for shipment, it is your responsibility to ensure compliance with applicable law. **Note: Equipment contaminated with some hazardous materials, such as semiconductor by-products, may not be suitable for airfreight - contact your transporter for advice.**
4. Remove all traces of hazardous gases: pass an inert gas through the equipment and any accessories that will be returned to BOC Edwards. Where possible, drain all fluids and lubricants from the equipment and its accessories.
5. Seal up all of the equipment's inlets and outlets (including those where accessories were attached) with blanking flanges or, for uncontaminated product, with heavy gauge tape.
6. Seal equipment in a thick polythene/polyethylene bag or sheet.
7. If the equipment is large, strap the equipment and its accessories to a wooden pallet. If the equipment is too small to be strapped to a pallet, pack it in a suitable strong box.
8. Fax or post a copy of the Declaration (HS2) to BOC Edwards. The Declaration must arrive before the equipment.
9. Give a copy of the Declaration (HS2) to the transporter. You must tell your transporter if the equipment is contaminated.
10. Seal the original Declaration in a suitable envelope: attach the envelope securely to the outside of the equipment package, in a clear weatherproof bag.

WRITE YOUR RETURN AUTHORISATION NUMBER CLEARLY ON THE OUTSIDE OF THE ENVELOPE OR ON THE OUTSIDE OF THE EQUIPMENT PACKAGE.

Return of BOC Edwards Equipment - Declaration

Return Authorisation Number:

You must:

- Know about all of the substances which have been used and produced in the equipment before you complete this Declaration
- Read the Return of BOC Edwards Equipment - Procedure (HS1) before you complete this Declaration
- Contact BOC Edwards to obtain a Return Authorisation Number and to obtain advice if you have any questions
- Send this form to BOC Edwards before you return your equipment

SECTION 1: EQUIPMENT

Equipment/System Name _____

Part Number _____

Serial Number _____

Has the equipment been used, tested or operated ?

 YES Go to Section 2 NO Go to Section 4

IF APPLICABLE:

Tool Reference Number _____

Process _____

Failure Date _____

Serial Number of Replacement Equipment _____

SECTION 2: SUBSTANCES IN CONTACT WITH THE EQUIPMENT
Are any substances used or produced in the equipment:

- Radioactive, biological or infectious agents, mercury, poly chlorinated biphenyls (PCBs), dioxins or sodium azide? (if YES, see Note 1) YES NO
- Hazardous to human health and safety? YES NO

Note 1 : BOC Edwards will not accept delivery of any equipment that is contaminated with radioactive substances, biological/infectious agents, mercury, PCB's, dioxins or sodium azide, unless you:

- Decontaminate the equipment
- Provide proof of decontamination

YOU MUST CONTACT BOC EDWARDS FOR ADVICE BEFORE YOU RETURN SUCH EQUIPMENT

SECTION 3: LIST OF SUBSTANCES IN CONTACT WITH THE EQUIPMENT

Substance name	Chemical Symbol	Precautions required (for example, use protective gloves, etc.)	Action required after a spill, leak or exposure

SECTION 4: RETURN INFORMATION

Reason for return and symptoms of malfunction _____

- If you have a warranty claim:
- who did you buy the equipment from ? _____
 - give the supplier's invoice number _____

SECTION 5: DECLARATION

Print your name: _____ Print your job title: _____

Print your organisation: _____

Print your address: _____

Telephone number: _____ Date of equipment delivery: _____

I have made reasonable enquiry and I have supplied accurate information in this Declaration. I have not withheld any information, and I have followed the Return of BOC Edwards Equipment - Procedure (HS1).

Note: Please print out this form, sign it and return the signed form as hard copy.

Signed: _____ Date _____

This page intentionally blank.

EUROPE/UNITED KINGDOM**BOC EDWARDS**

Manor Royal
Crawley
West Sussex, RH10 9LW
Tel +(44) 1293 528844
Fax +(44) 1293 533453

AMERICAS**USA HEADQUARTERS****BOC EDWARDS**

One Edwards Park
301 Ballardvale Street
Wilmington, MA 01887
Tel +(1) 978 658 5410
Toll Free (USA only) 1800 848 9800
Fax +(1) 978 658 5410

3901 Burton Drive
Santa Clara, CA 95054
Tel +(1) 408 496 1117
Fax +(1) 408 496 1118

1810 West Drake Drive
Suite 101
Tempe, AZ 85283
Tel +(1) 480 777 7007
Fax +(1) 480 777 2244

4117 Commercial Center Drive
Austin, TX 78744
Tel +(1) 512 416 0102
Fax +(1) 512 328 9846

3501 Island Avenue
Philadelphia, PA 19153
Tel +(1) 215 365 8653
Fax +(1) 978 756 6846

U.S. National Sales Center
Mon 8:30 A. M. - 8:00 P.M. EST
Tues 8:30 A. M. - 8:00 P.M. EST
Wed 8:30 A. M. - 8:00 P.M. EST
Thurs 8:30 A. M. - 8:00 P.M. EST
Fri 8:30 A. M. - 6:30 P.M. EST

BELGIUM**BOC EDWARDS**

Bergensesteenweg 709
B1600 Sint-Pieters-Leeuw
Brussels
Tel +(32) 2 363 0030
Fax +(32) 2 363 0064

BRAZIL**BOC DO BRAZIL LTDA**

Rua Bernado Wrona 222
02710 São Paulo-SP
Brazil
Tel +(55) 11 3952 5000
Fax +(55) 11 3965 2766

CANADA**BOC EDWARDS**

5975 Falbourne Street
Mississauga, Ontario L5R3W6
Canada
Tel +(1) 800 387 4076
Fax +(1) 905 501 1225

12055 Cote de Liesse
Dorval, Quebec H9P1B4
Canada
Tel +(1) 514 631 3501
Fax +(1) 514 631 3502

CHINA**BOC TRADING (SHANGHAI)
CO. LTD**

23 Fu Te Road(N),
Wai Gao Qiao Free Trade Zone
Pudong, Shanghai, 200131,
PRC, China
Tel +(86 21) 58669618
Fax +(86 21) 58669993

GERMANY**BOC EDWARDS**

Ammerthalstraße 36
85551 Kirchheim
Munich
Tel +(49) 89 99 19 18 0
Fax +(49) 89 99 19 18 99

FRANCE**BOC EDWARDS**

125 Avenue Louis Roche
92238 Gennevilliers, Cedex
Paris
Tel +(33) 1 47 98 24 01
Fax +(33) 1 47 98 44 54

HONG KONG S.A.R.**BOC EDWARDS (ASIA)**

12 Chun Yat Street
Tseung Kwan O Industrial
Estate
Tseung Kwan O, Kowloon
Hong Kong SAR
Tel +(852) 2372 2640
Fax +(852) 2796 9095

INDIA**BOC EDWARDS****DIVIN. OF BOC INDIA LIMITED**

203 Surya Kiran Building
19 Kasturba Gandhi Marg
New Delhi - 110 001
India
Tel +(91) 11 237 33087
Fax +(91) 11 551 0245

ISRAEL**EDWARDS ISRAEL VACUUM LTD**

5 Habarzel Blvd
Gat 2000 Industrial Zone
Qiryat Gat 82000
Tel +(972) 8 681 0633
Fax +(972) 8 681 0640

ITALY**BOC EDWARDS**

Via Carpaccio 35
20090 Trezzano sul Naviglio
Milan
Tel +(39) 2 48 4471
Fax +(39) 2 48 401638

JAPAN**HEADQUARTERS****BOC EDWARDS**

Shwa Shiba Park Building A-3F
2-4-1 Shibakoen Minato-ku
Tokyo, 105-0011
Tel +(81)(0) 3 5470 6530
Fax +(81)(0) 3 5470 6521

KOREA**HEADQUARTERS****SONGWON EDWARDS LTD**

5th FL. Daewoo Engineering
Bldg.
Soonae-dong
Bundang-gu, Sungnam City
Kyungki-do, Korea
Tel +(82) 31 716 7070
Fax +(82) 31738 1001

SONGWON EDWARDS LTD

625-7 Upsong-dong
Chunan City
Chungchong Nam-do
Korea
Tel +(82) 41 621 7070
Fax +(82) 41 621 7700

SINGAPORE**BOC EDWARDS (ASIA)**

42 Loyang Drive
Loyang Industrial Estate
Singapore 508962
Tel +(65) 546 8408
Fax +(65) 546 8407

TAIWAN, R.O.C.**EDWARDS TAIWAN LIMITED**

No. 434 Chung-hua Road
Toufen Town, Miaoli County
Taiwan R.O.C.
Tel +(886) 37 611422
Fax +(886) 37 611401

PLEASE CONTACT ANY OF THE ABOVE FOR DETAILS OF OTHER SALES AND SERVICE CENTERS IN YOUR AREA.

BOC Edwards is part of BOC Limited. BOC Edwards and the stripe symbol are trade marks of The BOC Group
© BOC Edwards 2004
Publication No. C100-04-895

www.bocedwards.com
info@bocedwards.com

