

Instruction Manual

IT20K, IT100, IT300 and IT800 Inlet Traps



Description	Item Number
ITO20K Inlet Catchpot	A441-10-000
ITC20K Inlet Chemical Trap	A444-10-000
ITD20K Inlet Desiccant Trap	A445-10-000
ITF20K Inlet Dust Filter	A442-15-000
ITO100 Inlet Catchpot	A441-02-000
ITC100 Inlet Chemical Trap	A444-02-000
ITF100 Inlet Dust Filter	A442-02-000
ITM100 High-Capacity Inlet Dust Filter	A443-02-000
ITO300 Inlet Catchpot	A441-03-000
ITC300 Inlet Chemical Trap	A444-03-000
ITF300 Inlet Dust Filter	A442-03-000
ITM300 High-Capacity Inlet Dust Filter	A443-03-000
ITO800 Inlet Catchpot	A441-04-000
ITC800 Inlet Chemical Trap	A444-04-000
ITF800 Inlet Dust Filter	A442-04-000
ITM800 High-Capacity Inlet Dust Filter	A443-04-000



This page has been intentionally left blank.

Contents

Section	Page
1 INTRODUCTION	1
1.1 Scope and Definitions	1
1.2 Product Description	1
1.2.1 General	1
1.2.2 ITO Inlet Catchpot	4
1.2.3 ITC Inlet Chemical Trap	4
1.2.4 ITD Inlet Desiccant Trap	4
1.2.5 ITF Inlet Dust Filter	4
1.2.6 ITM High-Capacity Inlet Dust Filter	4
2 TECHNICAL DATA	5
2.1 ITO Inlet Catchpot	5
2.2 ITC Inlet Chemical Trap	6
2.3 ITD20K Inlet Desiccant Trap	7
2.4 ITF Inlet Dust Filter	7
2.5 ITM High-Capacity Inlet Dust Filter	7
3 INSTALLATION	9
3.1 Unpack and Inspect	9
3.2 Install the Inlet Dust Filter	9
3.3 Install the IT100, IT300 or IT800 Inlet Trap, Catchpot or Filter	10
3.4 Fill the ITC Inlet Chemical Trap	10
3.5 Fill the ITD Inlet Desiccant Trap	10
4 OPERATION	11
4.1 Operating Notes	11
5 MAINTENANCE	13
5.1 Application of ITM Type Dust Filters in the Metallurgy Industry	13
5.2 Maintenance Frequency - Non Metallurgy Applications	14
5.3 Drain and Clean the ITO Inlet Catchpot	14
5.4 Clean and Refill the ITC Inlet Chemical Trap	15
5.5 Clean and Refill the ITD Inlet Desiccant Trap	15
5.6 Clean the ITF Inlet Dust Filter	15
5.7 Clean the ITM High-Capacity Inlet Dust Filter - Non Metallurgy Applications	16
6 STORAGE AND DISPOSAL	17
6.1 Storage	17
6.2 Disposal	17
7 SERVICE, SPARES AND ACCESSORIES	19
7.1 Introduction	19
7.2 Service	19
7.3 Spares Common to All Traps, Catchpots and Filters	19
7.4 Spares for ITC Inlet Chemical Trap	19
7.5 Spares for ITF Inlet Dust Filter	20
7.6 Spares for ITM High-capacity Inlet Dust Filter	20
For return of equipment, complete the HS Forms at the end of this manual.	

mv/8018/1208

Illustrations

Figure		Page
1	IT20K Inlet Trap	2
2	IT100, IT300 and IT800 Inlet Traps	3
3	Dimensions of IT20K inlet trap (mm)	5
4	Dimensions of IT20K inlet trap (mm)	6

Tables

Table		Page
1	Checklist of Components	9

Trademark credits

Fomblin® is a registered trademark of Ausimont SpA.
 LET-LOK® is a registered trademark of HAM-LET Group.
 Swagelok™ is trademark of Crawford Fitting Company.
 Viton™ is trademark of DuPont Dow Elastomers L.L.C.

1 INTRODUCTION

1.1 Scope and Definitions

This manual provides installation, operation and maintenance instructions for the following Edwards accessories:

- ITO20K, ITO100, ITO300 and ITO800 Inlet Catchpots
- ITC20K, ITC100, ITC300 and ITC800 Inlet Chemical Traps
- ITD20K Inlet Desiccant Trap
- ITF20K, ITF100, ITF300 and ITF800 Inlet Dust Filters
- ITM100, ITM300 and ITM800 High-Capacity Inlet Dust Filters.

You must use the accessory as specified in this manual

Read this manual before you install and operate the accessory. Important safety information is highlighted as WARNING and/or CAUTION instructions which must be followed. The use of WARNINGS and/or CAUTIONS is defined below.



WARNING

Warnings are given where failure to observe the instruction could result in injury or death to people.

CAUTION

Cautions are given where failure to observe the instruction could result in damage to the equipment, associated equipment and process.



Warning - refer to accompanying documentation.

The units used throughout this manual conform to SI international system of measurement followed by imperial units in parenthesis; SI (imperial).

1.2 Product Description

1.2.1 General

Inlet traps, dust filters and catchpots have an aluminium body with a removable metal top cover/or sight-glass. The inlet-port is at a tangent to the body to achieve a degree of centrifugal separation of solid and liquid particles.

All inlet traps, catchpots and filters of the same size have the same body. The traps and filters have containers and filter elements which fit inside the body as shown in Figures 1 and 2.

To provide maximum protection to the pumping system they should be installed as close to the vacuum pumping system as is possible.

Figure 1 - IT20K Inlet Trap

dcs-7268-001

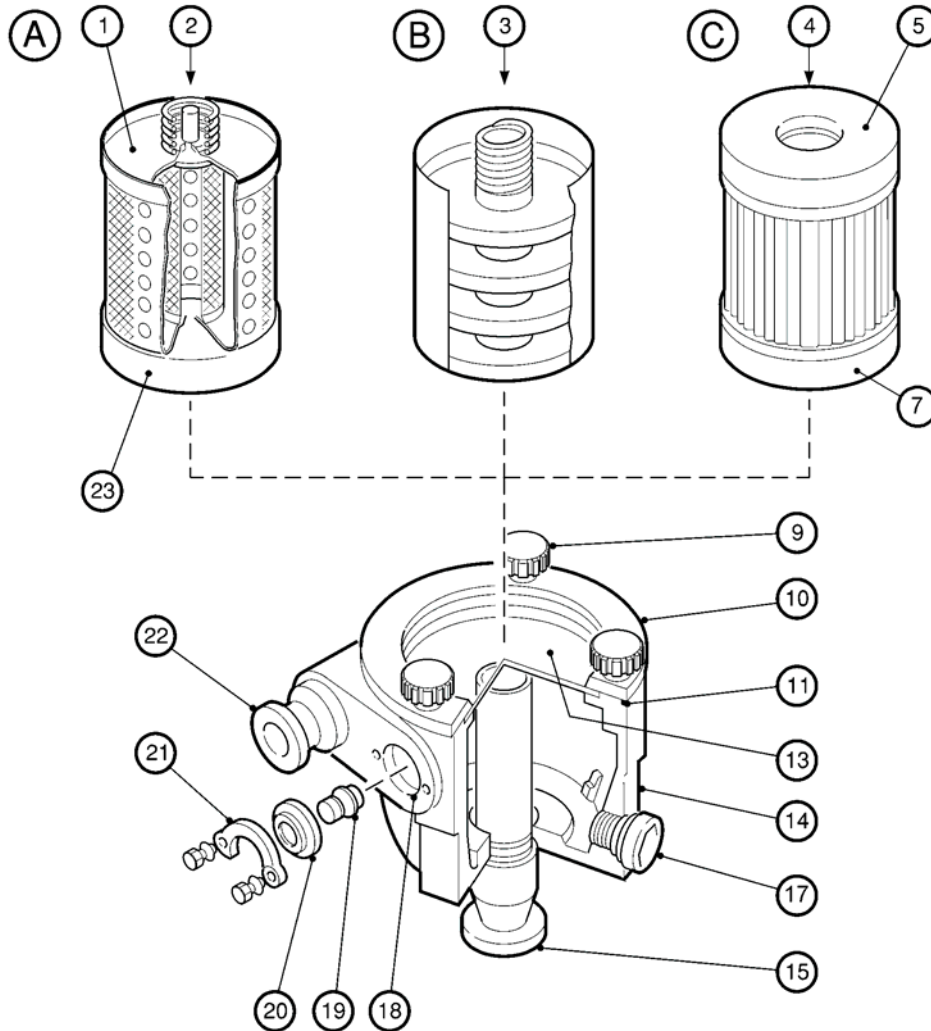

- A Inlet Chemical Trap
- B Inlet Desiccant Trap
- C Inlet Dust Filter

- | | | |
|----------------------------------|-----------------|---------------------------------|
| 1. Inner Cover | 9. Handwheel | 17. Drain-Plug |
| 2. Chemical Trap Basket Assembly | 10. Bezel | 18. Auxiliary Port |
| 3. Desiccant Trap Tray Assembly | 11. Gasket | 19. O' Ring and Blanking Plug |
| 4. Dust Filter Element | 12. Not Used | 20. Compression Sleeve |
| 5. Not Used | 13. Sight-Glass | 21. SC10 'C' Clamp |
| 6. Top Gasket | 14. Trap-Body | 22. Inlet-Port |
| 7. Dust Filter Bottom Gasket | 15. Outlet-Port | 23. Chemical Trap Bottom Gasket |
| 8. Not Used | 16. Not Used | |

Figure 2 - IT100, IT300 and IT800 Inlet Traps

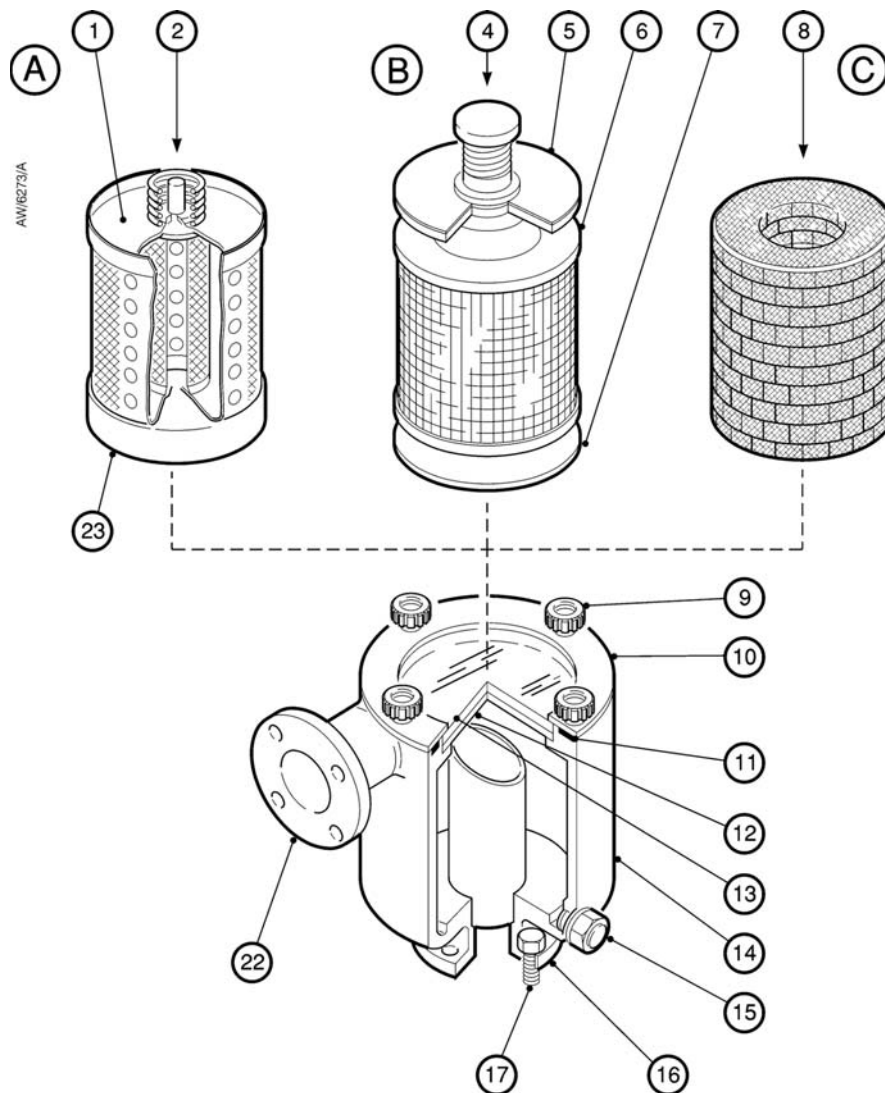

- A Inlet Chemical Trap
- B Inlet Desiccant Trap
- C Inlet Dust Filter

- | | | |
|--------------------------------------|-----------------------|---------------------------------|
| 1. Inner Cover | 9. Handwheel | 17. Outlet Flange Fixing Screws |
| 2. Chemical Trap Basket Assembly | 10. Bezel | 18. Not Used |
| 3. Not Used | 11. Gasket | 19. Not Used |
| 4. Dust Filter Element | 12. Sight Glass Cover | 20. Not Used |
| 5. Dust Filter Locating Spacer | 13. Sight-Glass | 21. Not Used |
| 6. Top Gasket | 14. Trap-Body | 22. Inlet-Port |
| 7. Dust Filter Bottom Gasket | 15. Drain-Plug | 23. Chemical Trap Bottom Gasket |
| 8. High-Capacity Dust Filter Element | 16. Outlet-Port | |

1.2.2 ITO Inlet Catchpot

The ITO Inlet Catchpot is used on vacuum processes where large quantities of vapour are produced. The catchpot traps liquid that would otherwise condense in the pipelines and drain towards the pump. The catchpot is also suitable for use on vacuum processes where froth or spray can go into the pump.

Refer to [Figure 1](#) for the ITO20K catchpot or to [Figure 2](#) for the ITO100, 300 and 800 catchpots for item numbers in brackets. The mixture of gas and liquid droplets enters the inlet of the catchpot (22). The liquid collects in the base of the body (14) and the gas passes through the outlet (16) into the pump.

You can see the level of the trapped liquid through the sight-glass (13). You can drain the trapped liquid from the catchpot through the drain-plug (15).

1.2.3 ITC Inlet Chemical Trap

The ITC Inlet Chemical Trap protects the pump against aggressive or heavy, lacquer-forming vapours which may damage the pump or contaminate the pump oil.

Refer to [Figure 1](#) for the ITC20K chemical trap or to [Figure 2](#) for the ITC100, 300 and 800 chemical traps for item numbers in brackets. The trap operates in the same way as the catchpot described in [Section 1.2.2](#) but, in addition, the vapour passes through the fine mesh stainless steel basket assembly (2) which holds the trapping material. Refer to [Section 7](#) for details of the choice of trapping materials available from Edwards as spares.

1.2.4 ITD Inlet Desiccant Trap

The ITD Inlet Desiccant Trap is used to trap limited quantities of water vapour to a low vapour pressure when the pump is operated at high pumping speeds. Phosphorous pentoxide (not supplied) is used as the desiccant.

Refer to [Figure 1](#) for item numbers in brackets. The trap operates in the same way as the catchpot described in [Section 1.2.2](#). In addition, the vapour passes through the stainless steel tray assembly (3), which holds the desiccant. You can see the condition of the desiccant through the sight-glass (13).

1.2.5 ITF Inlet Dust Filter

The ITF Inlet Dust Filter prevents the entry of dust particles into the pump.

Refer to [Figure 1](#) for the ITF20K dust filter or to [Figure 2](#) for the ITF100, 300 and 800 dust filters for item numbers in brackets. The inlet dust filter operates in a similar way to the catchpot described in [Section 1.2.2](#). In addition, the pumped gas passes through the dust filter element (4).

The filter material is a man-made fibre. You can see the condition of the filter element through the sight-glass (13).

1.2.6 ITM High-Capacity Inlet Dust Filter

The ITM High-capacity Inlet Dust Filter is used for applications that require fast pumpdown with high loads of dust and grit, which would rapidly clog the equivalent ITF Inlet Dust Filter element.

Refer to [Figure 2](#) for item numbers in brackets. The dust filter operates in a similar way to the catchpot described in [Section 1.2.2](#). In addition, the pumped gas passes through the high-capacity dust filter element (8).

The filter material is stainless steel mesh which can be made wet with oil for greater dust adhesion in those applications where the oil sealed vacuum pumps that can tolerate oil carryover are used e.g. oil sealed rotary vane or piston type pumps. The filter should not be oil wetted when using oil free drypumps.

2 TECHNICAL DATA

2.1 ITO Inlet Catchpot

	ITO20K	ITO100	IT0300	IT0800
Dimensions	Figure 3	Figure 4	Figure 4	Figure 4
Flange size (inlet and outlet)	NW25	ISO40	ISO63	ISO100
Mass (kg)	3.2	6.8	8.0	19.5
Capacity (litres)	1.84	5.47	7.87	9.50

Figure 3 - Dimensions of IT20K inlet trap (mm)

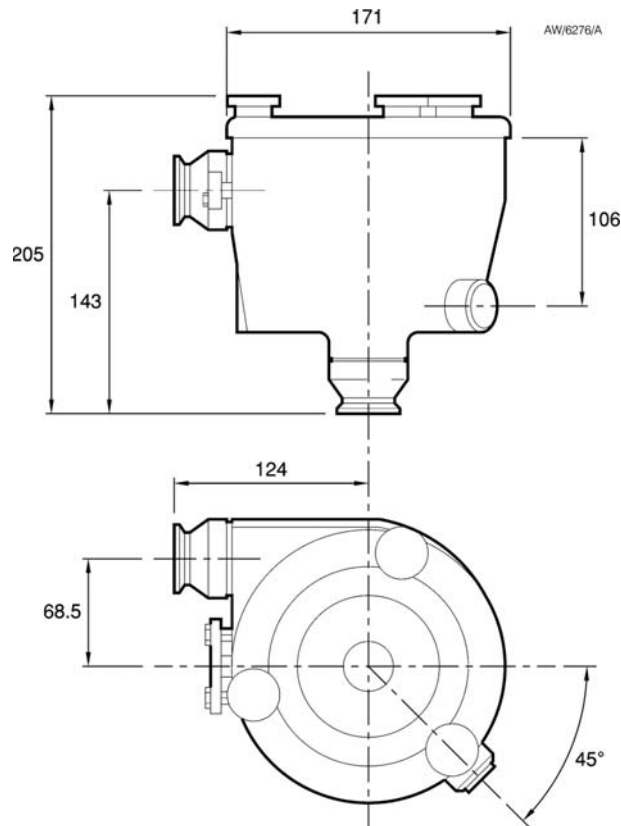

Figure 4 - Dimensions of IT20K inlet trap (mm)

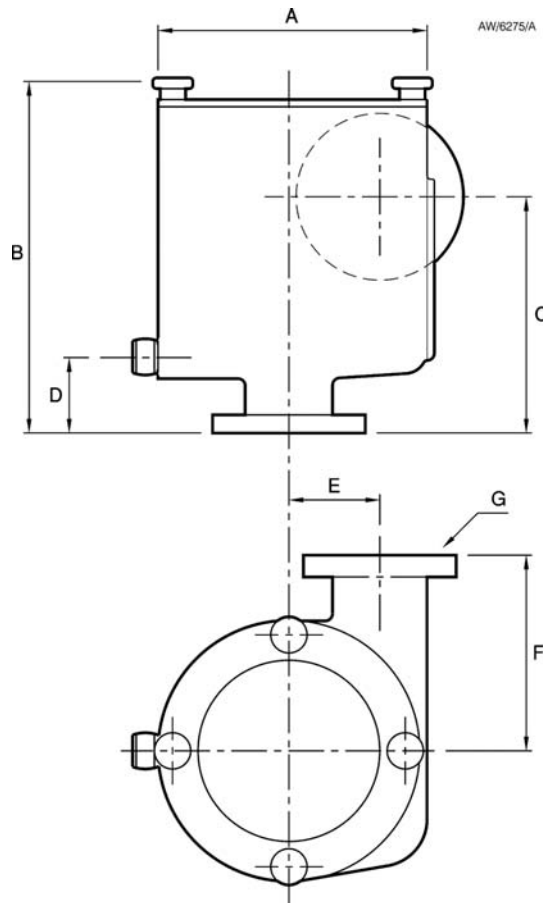

Figure Key	A	B	C	D	E	F	G
IT100	227	251	182	62	92	145	ISO40
IT300	227	308	210	62	80	165	ISO80
IT800	285	456	315	81	97	200	ISO100

2.2 ITC Inlet Chemical Trap

	ITC20K	ITC100	ITC300	ITC800
Dimensions	Figure 3	Figure 4	Figure 4	Figure 4
Flange size (inlet and outlet)	NW25	ISO40	ISO63	ISO100
Mass (kg)				
Trap-body (kg)	3.5	7.5	9.0	21.0
Charge (kg)*	0.4	0.75	1.1	3.3
Charge material	Activated charcoal or activated alumina			

* Mass of charge is given for activated charcoal

2.3 ITD20K Inlet Desiccant Trap

Dimensions	See Figure 3
Flange size (inlet and outlet)	NW25
Mass (kg)	
Trap-body (kg)	3.6
Dessicant (kg)*	0.12
Dessicant material (not supplied)r	Phosphorous pentoxide

2.4 ITF Inlet Dust Filter

	ITF20K	ITF100	ITF300	ITF800
Dimensions	Figure 3	Figure 4	Figure 4	Figure 4
Flange size (inlet and outlet)	NW25	ISO40	ISO63	ISO100
Mass (kg)				
Trap-body (kg)	3.4	7.0	8.3	20.2
Filter element (kg)*	0.3	0.4	0.5	1.0
Filter material		Man-made Fibre		
Filter efficiency (Tested to BS2831, dust number 2)		Better than 96%		
Reduction in pumping speed				
At 1 mbar			10%	
At 1 x 10 ⁻¹ mbar			25%	

2.5 IITM High-Capacity Inlet Dust Filter

	ITM100	ITFM00	ITM800
Dimensions	Figure 4	Figure 4	Figure 4
Flange size (inlet and outlet)	ISO40	ISO63	ISO100
Mass (kg)			
Trap-body (kg)	7.2	8.7	21.6
Filter element (kg)*	0.5	1.0	2.5
Filter material		Stainless Steel Mesh	
Filter efficiency particle size for BS2831 dust #2 particle size		Fused aluminium oxide powder	
Spectrum less than 13 microns		99.5 %	
Less than 7.5 microns		88.0+/- 8%	
Less than 5.0 microns		46.0+/- 6%	
Less than 3.5 microns		10.0+/- 3%	
Less than 2.5 microns		Less than 2.0%	

This page has been intentionally left blank.

3 INSTALLATION



WARNING

Obey the safety instructions given below and take note of appropriate precautions. If you do not, you may cause injury to people and damage to equipment.

- Use appropriate precautions when you come into contact with phosphorous pentoxide desiccant or phosphoric acid generated by the adsorption of moisture into phosphorous pentoxide.
- Phosphorous pentoxide attacks aluminium; prevent contact with the body of the trap.
- Do not expose activated charcoal or other sorbent material to atmosphere for longer than is necessary; keep storage containers sealed.
- Evacuate the trap as quickly as possible after it is prepared for use.

3.1 Unpack and Inspect

Remove all packing materials and inspect your accessory.

If your accessory is damaged, notify your supplier and the carrier in writing within three days; state the Item Number of the accessory together with your order number and your supplier's invoice number. Do not use the accessory if it is damaged.

Check that your package contains the items listed in Table 1.

Table 1 - Checklist of Components

Qty	Description	Check (✓)
1	The accessory item	<input type="checkbox"/>
1	Fitting Pack	<input type="checkbox"/>

If any of the items is missing, notify your supplier in writing within three days.

If the accessory is not to be used immediately, return it to its protective packaging. Store the accessory in suitable conditions; refer to Section 6.1.

3.2 Install the Inlet Dust Filter

You must install the inlet trap, catchpot or filter vertically. Refer to Figure 1 for items in brackets.

1. Clean the area around the pump-inlet.
2. Use the NW25 'O' ring assembly supplied with the pump and a clamp supplied in the fitting pack to connect the outlet (16) to your pump.
3. Use the NW25 'O' ring assembly and clamp supplied in the fitting pack to connect the inlet (22) to your vacuum system.
4. If necessary, you can mount a gauge or other small accessory to the auxiliary port (18). Use suitable SC10 or NW10 fittings (not supplied).

An ITF Inlet Dust Filter is supplied with the filter element already installed. Refer to Section 3.4 if you install an ITC Inlet Chemical Trap. Refer to Section 3.5 if you install an ITD Inlet Desiccant Trap.

3.3 Install the IT100, IT300 or IT800 Inlet Trap, Catchpot or Filter

You must install the inlet trap, catchpot or filter vertically. Refer to [Figure 2](#) for items in brackets.

1. Clean the area around the pump-inlet.
2. Use the 'O' ring assembly or Co-Seal supplied with pump and the screws and washers supplied in the fitting pack to connect the outlet (16) to your pump.
3. Use the 'O' ring assembly or Co-Seal and the screws and washers supplied in the fitting pack to connect the inlet (22) to your vacuum system.

An ITF Inlet Dust Filter or an ITM High-capacity Dust Filter is supplied with the filter element already installed. Refer to [Section 3.4](#) if you install an ITC Inlet Chemical Trap.

3.4 Fill the ITC Inlet Chemical Trap

Refer to [Figure 1](#) for the ITC20K chemical trap or to [Figure 2](#) for the ITC100, 300 and 800 chemical traps for item numbers in brackets.

1. Undo the handwheels (9) and remove the bezel (10), the gasket (11), the sight-glass cover (12, if fitted) and the sight-glass (13). If necessary, insert a small blade screwdriver into the slot in the rim of the trap-body to remove the sight-glass.
2. Lift out the basket assembly (2), undo the knurled nut that secures the inner cover (1) and remove the inner cover.
3. Fill the basket with the trap material. Shake the basket to compact the trap material and fill it to approximately 6 mm below the top of the stud that holds the inner cover. Refit the inner cover.
4. Place the basket in the trap-body. Refit the sight-glass assembly and secure it with the handwheels.

3.5 Fill the ITD Inlet Desiccant Trap

Refer to [Figure 1](#) for item numbers in brackets.

1. Undo the handwheels (9) and remove the bezel (10), the gasket (11) and the sight-glass (13). If necessary, insert a small blade screwdriver into the slot in the rim of the trap-body to remove the sight-glass.
2. Lift out the desiccant tray assembly (3).
3. Fill the trays with a thin layer of desiccant (approximately one quarter full) and leave the surface loosely packed to expose a large surface area.
4. Place the tray assembly in the trap-body. Refit the sight-glass assembly and secure it with the handwheels.

4 OPERATION

4.1 Operating Notes

Check the inlet dust filter regularly and clean or replace the filter elements as described in [Section 5](#).

If your vacuum system will be left for long periods at atmospheric pressure, fit isolation-valves at the inlet and outlet of the filter. The inlet dust filter can then be stored under vacuum and the inlet dust filter will remain clean and dry for a longer period.

Do not open the drain port of an inlet trap when it is under vacuum. If you do, material trapped in the inlet trap can flow back into your process chamber

This page has been intentionally left blank.

5 MAINTENANCE



WARNING

Take all the necessary precautions if toxic or dangerous substances have been pumped through the inlet trap. Wear protective clothing when you come into contact with contaminated filters and filter elements.



WARNING

Isolate the pump from the electrical supply before you start maintenance.

Note: Ensure that the inlet trap is at atmospheric pressure before you start maintenance. Do not use the drain port to vent the inlet trap.

Inspect the inlet trap as part of maintenance. If a sight-glass is fitted and this is scratched or chipped, you must replace the sight-glass before you use the inlet trap again.

5.1 Application of ITM Type Dust Filters in the Metallurgy Industry



WARNING

ITF type filters are not suitable for applications that would trap materials likely to react on exposure to air.

The use of filters to capture fine dust and larger particles could result in the trapping of non-oxidised or partially oxidised metallic powders in the filter element. Some of these materials may react when exposed to air and an ignition source.

For all applications where metallic dust particles are present and where the ITM filters are installed, it is recommended that the filter elements be periodically inspected and cleaned. The frequency of this inspection needs to be determined as it is process dependent. Initially this inspection should be on a weekly basis until an acceptable interval can be established. This is necessary to ensure the quantity of metallic dust present is controlled as this will minimise the potential for heat damage should ignition and combustion of the dust occur.



WARNING

When venting ITM Filters it should be assumed that they contain reactive materials and care should be taken when removing or handling the filter element.

To remove the filter element, first isolate the vacuum pumps from the process chamber. It is preferable that the isolation valve be placed close to the inlet of the ITM filter.

Switch off the vacuum pump and vent the vacuum pump and ITM filter to atmosphere. Leave the filter at atmospheric pressure for 5-10 minutes to allow any potential reaction to start. If the filter body or top plate becomes heated, then restart the vacuum pumps but do not open the pump isolation valve installed at the ITM filter inlet. This will remove oxygen from the reaction.

If there is no sign of a reaction occurring, remove the top plate from the ITM filter to expose the element, check again that there is no evidence of reaction before proceeding to remove the filter. In the event of a reaction, replace the top plate and switch on the vacuum pumps.

The filter element should be removed to a well-ventilated area away from naked flames or hot surfaces etc and should be immersed in clean water. It is possible for hydrogen to be released during the water wash procedure.

Dismantle and inspect the inlet dust filter. Refer to [Figure 2](#) for items in brackets.

1. Undo the handwheels (9); remove the bezel (10), the gasket (11) and the sight-glass (13).
2. Lift out the high-capacity filter element (8).
3. If the element is in good condition, wash it in a suitable cleaning solution. Replace the element if it is damaged or heavily contaminated.
4. If necessary, remove dry dust from the inside of the trap-body with a vacuum cleaner and then wipe the inside with a clean, lint-free cloth.
5. If necessary, immerse the clean high-capacity filter element in a bath of vacuum pump oil and allow it to drain over the bath for several hours but not for dry pumps.
6. Place the high-capacity filter element in the trap-body.
7. Inspect the sight-glass gasket (11); replace the gasket if it is damaged. Refit the sight-glass assembly and secure it with the handwheels.

Measure the filter element weight and compare this to the guide values for clean filters to ensure effective removal of accumulated dust. The weights of the individual clean filter elements for ITM3000 and ITM5000 are listed below.

Item Number	Description	Individual Element Weights
A223-05-020	ITM100	0.78 kg
A223-05-019	ITM300	0.50 kg
A223-05-018	ITM800	2.28 kg

The filter element can now be replaced in the ITM filter body following the same procedure as for removal.

5.2 Maintenance Frequency - Non Metallurgy Applications

Use the procedures in Sections 5.3 to 5.7 drain, clean and refill the inlet traps as necessary. How often you need to use these procedures depends on your application; determine your maintenance plan according to your experience.

5.3 Drain and Clean the ITO Inlet Catchpot

Refer to [Figure 1](#) for the ITO20K catchpot or to [Figure 2](#) for the ITO100, 300 and 800 catchpots for items in brackets.

1. Place a suitable container under the drain-plug (15); unscrew the drain-plug and drain any fluid into the container. Dispose of the fluid safely; refer to [Section 6.2](#).
2. If necessary (that is, if there are solids or liquids still trapped in the catchpot):
 - Undo the handwheels (9); remove the bezel (10), the gasket (11), the sight-glass cover (12, if fitted) and the sight-glass (13).
 - If necessary, shake out any solids into a suitable container.
 - Dispose of the solids safely; refer to [Section 6.2](#).
 - Wipe the inside of the trap-body (14) and the sight-glass (13) with a clean, lint-free cloth. Alternatively, clean the inside of the catchpot with a clean cloth, water and detergent or a suitable cleaning solution, depending on the condition of the catchpot and the materials trapped.
 - Replace the gasket (11) if it is damaged, then refit the bezel (10), the gasket (11), the sight-glass cover (12, if fitted) and the sight-glass (13) and secure with the handwheels (9).
3. Refit the drain-plug.

5.4 Clean and Refill the ITC Inlet Chemical Trap

Refer to [Figure 1](#) for the ITC20K trap or to [Figure 2](#) for the ITC100, 300 and 800 traps for items in brackets.

1. Undo the handwheels (9), remove the bezel (10), the gasket (11), The sight-glass cover (12, if fitted) and the sight-glass (13).
2. Lift out the chemical trap basket assembly (2). Undo the knurled nut that holds the inner cover (1) and remove the inner cover from the basket.
3. Shake out the used trap material into a suitable container. Dispose of the used trap material safely; refer to [Section 6.2](#).
4. If necessary, clean the basket with a clean cloth, water and detergent or a suitable cleaning solution, depending on its condition.
5. Refill the basket with new trap material. Shake the basket to compact the trap material and fill it to approximately 6 mm below the top of the stud that holds the inner cover. Refit the inner cover.
6. Remove the bottom gasket (23) from the inside of the trap-body (14). If necessary, clean the inside of the trap-body with a clean, lint-free cloth.
7. Replace the bottom gasket (23) if it is damaged. Place the bottom gasket and the basket in the trap-body.
8. Inspect the sight-glass gasket (11); replace the gasket if it is damaged. Refit the sight-glass assembly and secure it with the handwheels.

5.5 Clean and Refill the ITD Inlet Desiccant Trap

Refer to [Figure 1](#) for items in brackets.

1. Undo the handwheels (9), remove the bezel (10), the gasket (11) and the sight-glass (13).
2. Lift out the desiccant trap tray assembly (3).
3. Shake out the used desiccant into a suitable container. Dispose of the used desiccant safely; refer to [Section 6.2](#).
4. Wash the tray assembly in clean water and dry it thoroughly. If necessary, clean the inside of the trap-body with a clean, lint-free cloth.
5. Refill the trays with a thin layer of new desiccant (approximately one Quarter full) and leave the surface loosely packed to expose a large surface area. Place the tray assembly in the trap-body.
6. Inspect the sight-glass gasket (11); replace the gasket if it is damaged. Refit the sight-glass assembly and secure it with the handwheels.

5.6 Clean the ITF Inlet Dust Filter

Refer to [Figure 1](#) for the ITF20K filter or to [Figure 2](#) for the ITF100, 300 and 800 filters or items in brackets.

1. Undo the handwheels (9), remove the bezel (10), the gasket (11) and the sight-glass (13).
2. Lift off the filter locating spacer (5, if fitted) and the top gasket (6) and then lift out the filter element (4) and the bottom gasket (7).
3. Clean the element if it is in good condition. Remove dry dust with a Vacuum cleaner. Replace the element if it is damaged or contaminated. Replace the gaskets if they are damaged.
4. If necessary, remove dry dust from the inside of the trap-body with a Vacuum cleaner and then wipe the inside with a clean, lint-free cloth.

5. Place the bottom gasket, filter element and top gasket in the trap-body.
6. Inspect the sight-glass gasket (11); replace the gasket if it is damaged. Refit the sight-glass assembly and secure it with the handwheels.

5.7 Clean the ITM High-Capacity Inlet Dust Filter - Non Metallurgy Applications

Refer to [Figure 2](#) for items in brackets.

1. Undo the handwheels (9), remove the bezel (10), the gasket (11) the top plate or the sight-glass (13).
2. Lift out the high-capacity filter element (8).
3. If the element is in good condition, wash it in a suitable cleaning solution. Replace the element if it is damaged or heavily contaminated.
4. If necessary, remove dry dust from the inside of the trap-body with a vacuum cleaner and then wipe the inside with a clean, lint-free cloth.

Filtration efficiency can be improved by oil wetting the ITM filter element. This is possible in applications where the vacuum pumps can tolerate oil carryover e.g. when using oil sealed rotary vane or piston pumps but not in applications where dry oil free vacuum pumps are used. To oil wet the ITM filter element immerse the clean high-capacity filter element in a bath of vacuum pump oil and allow to drain over the bath for several hours before refitting the element in the ITM filter body.

5. If necessary, immerse the clean high-capacity filter element in a bath of vacuum pump oil and allow it to drain over the bath for several hours but not for dry pumps.
6. Place the high-capacity filter element in the trap-body.
7. Inspect the top plate gasket (11); replace the gasket if it is damaged. Refit the sight-glass assembly and secure it with the handwheels.

6 STORAGE AND DISPOSAL

6.1 Storage

1. Clean the inlet dust filter as described in [Section 5](#).
2. Refit protective covers over the inlet and outlet-ports.
3. Place the accessory in its protective packaging.
4. Store the accessory in a cool dry place until required.
5. When required for use, prepare and install the accessory as described in [Section 3](#).

6.2 Disposal

Dispose of the accessory and any components removed from it safely in accordance with all local and national safety and environmental requirements.

Take particular care with components, liquids, chemicals and materials that have been contaminated with dangerous substances.

This page has been intentionally left blank.

7 SERVICE, SPARES AND ACCESSORIES

7.1 Introduction

Edwards products, spares and accessories are available from Edwards companies in Belgium, Brazil, Canada, France, Germany, Hong Kong, Italy, Japan, Korea, Switzerland, United Kingdom, USA, and a worldwide network of distributors. The majority of these centers employ Service Engineers who have undergone comprehensive Edwards training courses.

Order spare parts and accessories from the nearest Edwards company or distributor. When ordering, provide the following information:

- Model and Item Number of your equipment.
- Serial number (if any).
- Item Number and description of part.

7.2 Service

A worldwide network of Edwards Service Centres support Edwards products. Each Service Centre offers a wide range of options including equipment decontamination; service exchange; repair; rebuild and testing to factory specifications. Equipment, which has been serviced, repaired or rebuilt, is returned with a full warranty.

Your local Service Centre can also provide Edwards engineers to support on-site maintenance, service or repair of your equipment.

For more information about service options, contact you're nearest Service Centre or other Edwards company.

7.3 Spares Common to All Traps, Catchpots and Filters

Description	Item Number
Sight-glass o-ring for ITx20K	H021-25-201
Sight-glass gasket for ITx20K	A271-59-603
Sight-glass o-ring for ITx100 and 300	H021-20-103
Sight-glass gasket for ITx100 and 300	A271-59-601
Sight-glass o-ring for ITx800	H021-20-112
Sight-glass gasket for ITx800	A271-59-602

7.4 Spares for ITC Inlet Chemical Trap

Description	Item Number
Activated charcoal 0.5 kg	H122-05-001
Activated charcoal 3.0 kg	H122-05-002
Activated alumina 0.45 kg	H026-00-050

7.5 Spares for ITF Inlet Dust Filter

Description	Item Number
Filter element kit for ITF20K (element and gasket)	A442-01-800
Filter element kit for ITF100 (element and gasket)	A442-02-800
Filter element kit for ITF300 (element and gasket)	A442-03-800
Filter element kit for ITF800 (element and gasket)	A442-04-800

7.6 Spares for ITM High-capacity Inlet Dust Filter

Description	Item Number
Filter element kit for ITM100 (element only)	A223-05-020
Filter element kit for ITM300 (element only)	A223-05-019
Filter element kit for ITM800 (element only)	A223-05-018