



**Agilent Technologies**

*Vacuum Products Division*

***VPI Valve and CT-100  
Speed  
Control Kit***

*INSTRUCTION MANUAL*

Part No. 699904375

Rev. B

June 2009

# VPI Valve and CT-100 Speed Control Kit



# Warranty

Products manufactured by Seller are warranted against defects in materials and workmanship for twelve (12) months from date of shipment thereof to Customer, and Seller's liability under valid warranty claims is limited, at the option of Seller, to repair, replacement, or refund an equitable portion of the purchase price of the Product. Items expendable in normal use are not covered by this warranty. All warranty replacement or repair of parts shall be limited to equipment malfunctions which, in the sole opinion of Seller, are due or traceable to defects in original materials or workmanship. All obligations of Seller under this warranty shall cease in the event of abuse, accident, alteration, misuse, or neglect of the equipment. In-warranty repaired or replaced parts are warranted only for the remaining unexpired portion of the original warranty period applicable to the repaired or replaced parts. After expiration of the applicable warranty period, Customer shall be charged at the then current prices for parts, labor, and transportation.

When products are used with toxic chemicals, or in an atmosphere that is dangerous to the health of humans, or is environmentally unsafe, it will be the responsibility of the Customer to have the product cleaned by an independent agency skilled and approved in handling and cleaning contaminated materials before the product will be accepted by Agilent, Inc. for repair and/or replacement.

Reasonable care must be used to avoid hazards. Seller expressly disclaims responsibility for loss or damage caused by use of its Products other than in accordance with proper operating procedures.

Except as stated herein, Seller makes no warranty, express or implied (either in fact or by operation of law), statutory or otherwise; and, except as stated herein, Seller shall have no liability under any warranty, express or implied (either in fact or by operation of law), statutory or otherwise. Statements made by any person, including representatives of Seller, which are inconsistent or in conflict with the terms of this warranty shall not be binding upon Seller unless reduced to writing and approved by an officer of Seller.

## Warranty Replacement and Adjustment

All claims under warranty must be made promptly after occurrence of circumstances giving rise thereto, and must be received within the applicable warranty period by Seller or its authorized representative. Such claims should include the Product serial number, the date of shipment, and a full description of the circumstances giving rise to the claim. Before any Products are returned for repair and/or adjustment, written authorization from Seller or its authorized representative for the return and instructions as to how and where these Products should be returned must be obtained. Any Product returned to Seller for examination shall be prepaid via the means of transportation indicated as acceptable by Seller. Seller reserves the right to reject any warranty claim not promptly reported and any warranty claim on any item that has been altered or has been returned by non-acceptable means of transportation. When any Product is returned for examination and inspection, or for any other reason, Customer shall be responsible for all damage resulting from improper packing or handling, and for loss in transit, notwithstanding any defect or non-conformity in the Product. In all cases, Seller has the sole responsibility for determining the cause and nature of failure, and Seller's determination with regard thereto shall be final.

If it is found that Seller's Product has been returned without cause and is still serviceable, Customer will be notified and the Product returned at its expense; in addition, a charge for testing and examination may be made on Products so returned. 3/1/00

## VPI Valve and CT-100 Speed Control Kit

---

*This page intentionally left blank.*

# Preface

## Documentation Conventions

This manual uses the following documentation conventions:

**WARNING**



*Warnings indicate a particular procedure or practice, which if not followed correctly, could lead to serious injury.*

**CAUTION**



*Cautions indicate a particular procedure or practice, which if not followed, could cause damage to the equipment.*

**NOTE**



*Notes contain important information.*

Before operating or servicing equipment, read and thoroughly understand all operation/maintenance manuals provided by Agilent. Be aware of the hazards associated with this equipment, know how to recognize potentially hazardous conditions, and how to avoid them. Read carefully and strictly observe all cautions and warnings. The consequences of unskilled, improper, or careless operation of the equipment can be serious.

In addition, consult local, state, and national agencies regarding specific requirements and regulations. Address any safety, operation, and/or maintenance questions to your nearest Agilent office.

## VPI Valve and CT-100 Speed Control Kit

---

*This page intentionally left blank.*

### Description

Agilent offers a speed control kit, with and without VPI valve (Figure 1-1 and Figure 1-2 respectively), for use with the TriScroll inverter pumps (Agilent P/N#: TS0X00INVXX). The speed control kit allows automatic switching from full pumping speed to a lower speed. Operation at lower speed reduces noise and can extend maintenance intervals.



**Figure 1-1 TriScroll Inverter Pump With Speed Control Kit and No VPI Valve**

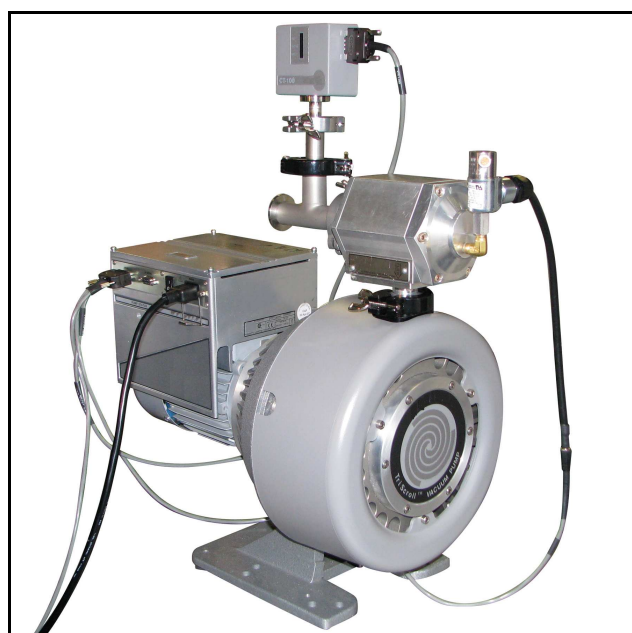
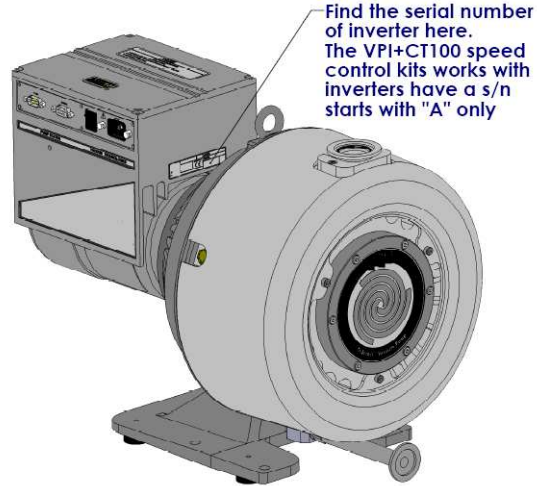

**Figure 1-2 TriScroll Inverter Pump With Speed Control Kit and VPI Valve**

## VPI Valve and CT-100 Speed Control Kit



*For the speed control kit with a VPI valve, the pump inverter serial number must start with an A (Figure 1-3).*



**Figure 1-3 Serial Number Location**

This kit consists of the CT-100 Active Rough Vacuum Gauge, Communication Cable, 24 VDC Power Supply, Power Splitter Cord, Tee, Centering Ring(s), Clamp(s), and an optional VPI valve. Table 1-1 lists order numbers and more details.

**Table 1-1 Components for Speed Control Kits**

		CT100 Speed Control Kit		CT100 Speed Control with VPI Kit	
		NW25	NW40	NW25	NW40
		PTSCNTRLKIT1	PTSCNTRLKIT2	PTSCNTRLKIT3	PTSCNTRLKIT4
VPI Valve	VPI NW25	0	0	1	0
	VPI NW40	0	0	0	1
CT100	CT100 NW25	1	0	1	0
	CT100 NW40	0	1	0	1
Cable	CT100 control cable	1	1	0	0
	CT100+VPI control cable	0	0	1	1



## VPI Valve and CT-100 Speed Control Kit

**Table 1-1 Components for Speed Control Kits (Continued)**

		CT100 Speed Control Kit		CT100 Speed Control with VPI Kit	
Power	24V DC power supply	1	1	1	1
	Splitter cable	1	1	1	1
Accessories	Centering ring NW25	2	0	3	0
	Centering ring NW40	0	2	0	3
	Clamp NW25	2	0	3	0
	Clamp NW40	0	2	0	3
	Tee NW25	1	0	1	0
	Tee NW40	0	1	0	1

Two set points can be set on the CT100 gauge. When the pressure is:

- Over the high set point (SP1), the inverter drives the pump at full speed\*.
- Below the lower set point value (SP2), the scroll is driven at minimum speed\*\*.
- Higher than set point 2, but lower than set point 1, the driving frequency is given by:  
(full speed + minimum speed)/2 (Figure 1-4 on page 1-4).

Set points are user-settable. If a faster pump down is preferred, a lower SP1 allows the pump to stay longer at full speed. If quieter operation is preferred, a higher SP2 allows the pump to run longer at low frequency.

\* Full speed: customized frequency setting via Agilent T-plus software if used. Factory setting is 62 Hz.

\*\* Minimum speed: 35 Hz

## VPI Valve and CT-100 Speed Control Kit

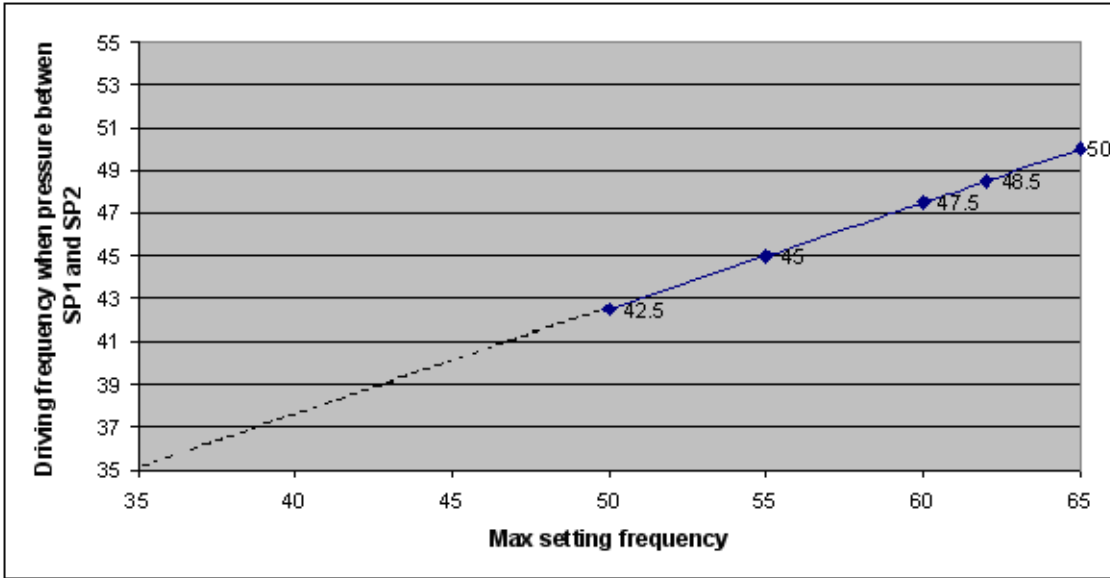

**Figure 1-4 Driving Frequency**

Pumping speed changes compared with factory setting, but the effect reduces when the inlet pressure goes down. Figure 1-5 shows the pumping speed drop percentage at peak pumping speed and at 100 mtorr inlet pressure.

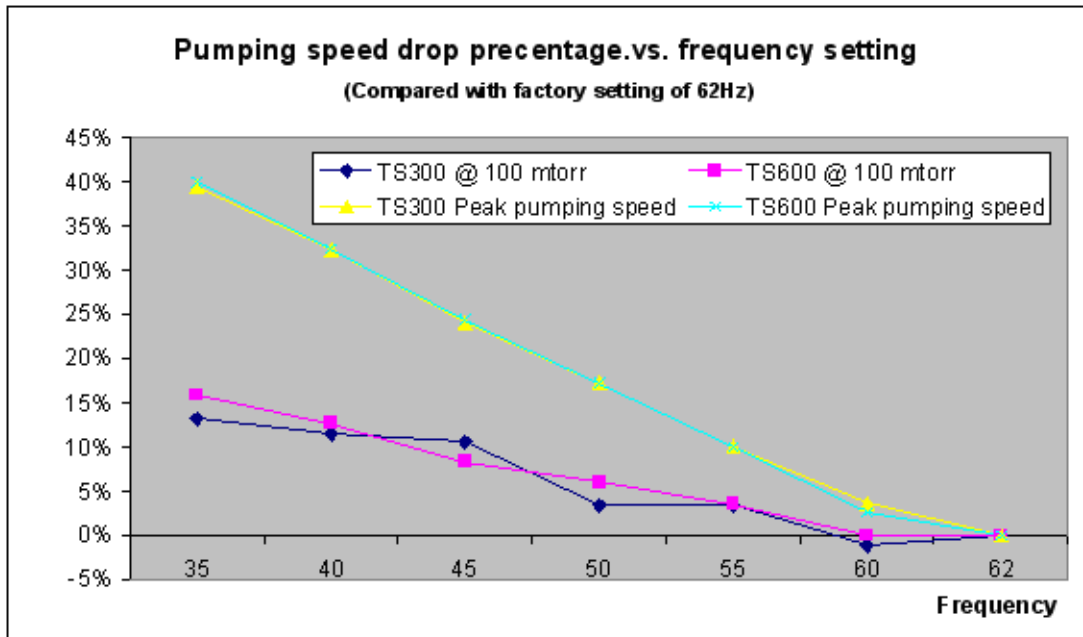

**Figure 1-5 Pumping Speed Drop Percentage**

# Installation and Operation



*To ensure proper operation, and to prevent damage, the kit must be installed and operated only as specified.*



*Disconnect the mains power before assembly and disassembly.*

*For PTSCNTRLKIT1 and PTSCNTRLKIT2:*

1. Select the proper model.
2. Mount the Tee and CT-100 as shown in Figure 1-6 with the Centering Ring and Quick Clamp.

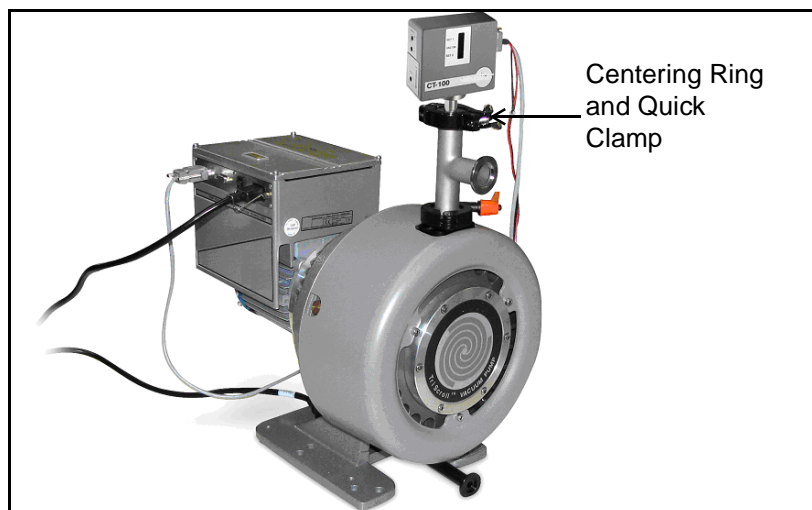

**Figure 1-6 Centering Ring and Quick Clamp**

3. Plug the communication cable DB9 connector labeled *to CT100* into the CT-100 gauge and plug the other connector into the inverter I/O.
4. Connect the 2.5/5.5 mm DC communication cable connector into the 24 VDC power supply output.
5. Plug one of the power splitter cord's C14 outputs into the 24 VDC power supply, and the other into the inverter power entry module.
6. Set the set points as specified in Table 1-2.
7. Connect the pump's C13 plug to the mains power, and switch the inverter on.

## VPI Valve and CT-100 Speed Control Kit

---

For *PTSCNTRLKIT3* and *PTSCNTRLKIT4*:

1. Select the proper model.
2. Mount the Tee, CT-100, and VPI as shown in Figure 1-2 on page 1-1 2 with the centering ring and quick clamp.
3. Connect the inverter and CT-100 with the communication cable. Plug the DB9 labeled *CT100* to the CT-100 gauge, and connect the other end to the inverter I/O.
4. Connect the 2.5/5.5mm DC communication cable connector to the 24 VDC power supply.
5. Connect the 2.1/5.5mm VPI Valve connector to the VPI valve.
6. Plug one of the power splitter cord C14 outputs to the 24V DC power supply, and the other to the inverter power entry module.
7. Set the set points, refer to “Setting the Setpoints”.
8. Power the pump with C13 plug to the mains power, and switch on the inverter.

### Setting the Setpoints

The two set points are screwdriver adjusted as shown in Figure 1-7.

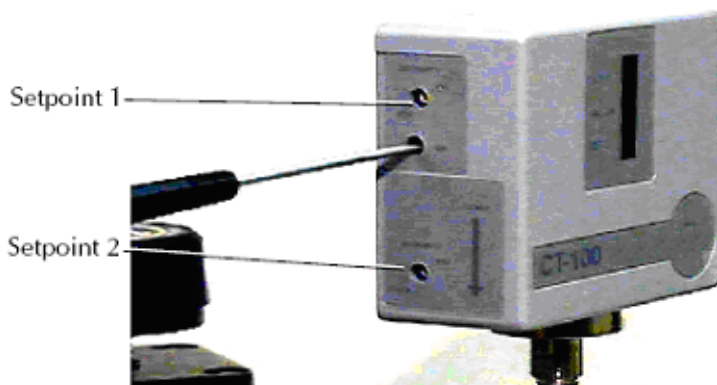

**Figure 1-7 Setpoint Screwdriver Adjustments**

The output voltage of 1 VDC to 9 VDC covers the measurement range from vacuum to atmospheric. The set points can be extended beyond this range to the limits of 0 to 12 V for alarm settings beyond the accurate range of the gauge.

Examples:

- ❑ If the set point is greater than the reading for ATM, the output and the LED will always be active whenever power is applied to the gauge.
- ❑ If the set point is lower than the VAC reading, the set point can indicate a sensor failure.

## VPI Valve and CT-100 Speed Control Kit

When a set point is activated, the corresponding open collector, on pin 1 for set point 2 and on pin 2 for set point 1, becomes active and can sink current to the common ground. This connection may be used to drive a relay coil or other indicator that shows the trigger set point has been reached.

There are two ways to adjust the set points:

- ❑ Rotate the potentiometer screw by referring to the line markings on the front panel. These markings provide approximate pressure settings throughout the range of measurable vacuum.
- ❑ Use a voltmeter to measure the voltage equivalent of the pressure at which the alarm is to be set. This provides the most accurate way to establish a set point.

### Set Point Adjustment from Panel Markings

Each set point can be brought to an approximate pressure level by rotating the screwdriver adjustment according to the markings on the side panel surrounding the potentiometer. These markings are placed approximately at each decade of vacuum (Figure 1-8 and Table 1-2).

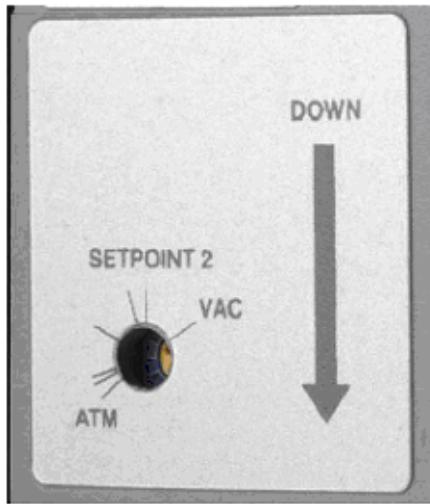

**Figure 1-8 Side Panel Potentiometer Pressure Markings**

**Table 1-2 Pressure Markings**

Marking Clockwise	Torr	Mbar
ATM	760	1000
1	100	133
2	10	13.3
3	1	1.33

## VPI Valve and CT-100 Speed Control Kit

**Table 1-2 Pressure Markings (Continued)**

Marking Clockwise	Torr	Mbar
4	100 mT	$1.33 \times 10^{-1}$
5	10 mT	$1.33 \times 10^{-2}$
VAC	1 mT	$1.33 \times 10^{-3}$

Voltmeter adjustment of a set point:

1. Connect power to a calibrated CT-100 gauge. The voltage to be measured is from 0 to 12 VDC. If necessary, set the voltmeter scale to measure this range.
2. Attach the voltmeter ground to pin 8 on the D-connector cable.
3. Attach the voltmeter probe to pin 9 to measure set point 1 and to pin 7 for set point 2 as determined from Table 1-3. At this point you are reading the voltage on the wiper of the selected potentiometer.
4. Refer to the Table 1-4 for the gas you wish to measure. This data is given in Torr, mbar, and Pa on the pressure X-axis.
5. Locate the pressure for the set point on the X-axis of the chart and read off the voltage from the Y-axis, or find a specific pressure in the table and its associated voltage. Use a linear interpolation between the nearest data points for intermediate values.
6. Adjust the screwdriver potentiometer for the appropriate setpoint until the voltmeter reads the value indicated on the curve or the table.

**NOTE**



*You can calibrate to three decimal places,  $\pm 1$  millivolt. If you are measuring a different gas, the set points must be readjusted.*

**Table 1-3 D-subminiature Connector Pinouts**

Pin No.	Description
1	Relay #2 N.O.
2	Relay #1 N.O.
3	Power Input (+24 VDC)
4	Power Ground
5	Analog Output
6	Relay Common
7	Setpoint #2 Output
8	Signal Ground

## VPI Valve and CT-100 Speed Control Kit

**Table 1-3 D-subminiature Connector Pinouts (Continued)**

Pin No.	Description
9	Setpoint #1 Output
Shell	Gauge Chassis Ground: Connect to the power supply

**Table 1-4 Air/N<sub>2</sub> and Argon Calibration Data**

Pressure (Torr)	Pressure (mbar)	Pressure (Pa)	V <sub>out</sub> (Air/N <sub>2</sub> )	V <sub>out</sub> (Argon)
1.00E-04	1.33E-04	1.33E-02	1.002	1.002
2.00E-04	2.66E-04	2.66E-02	1.005	1.003
5.00E-04	6.65E-04	6.65E-02	1.007	1.005
1.00E-03	1.33E-03	1.33E-01	1.013	1.008
2.00E-03	2.66E-03	2.66E-01	1.025	1.015
5.00E-03	6.65E-03	6.65E-01	1.055	1.036
1.00E-02	1.33E-02	1.33E-00	1.111	1.069
2.00E-02	2.66E-02	2.66E-00	1.216	1.136
5.00E-02	6.65E-02	6.65E-00	1.501	1.330
1.00E-01	1.33E-01	1.33E+01	1.940	1.562
2.00E-01	2.66E-01	2.66E+01	2.540	2.085
5.00E-01	6.65E-01	6.65E+01	3.678	2.977
1.00E+00	1.33E+00	1.33E+02	4.737	3.787
2.00E+00	2.66E+00	2.66E+02	5.703	4.312
5.00E+00	6.65E+00	6.65E+02	6.547	5.288
1.00E+01	1.33E+01	1.33E+03	6.999	5.598
2.00E+01	2.66E+01	2.66E+03	7.241	5.892
5.00E+01	6.65E+01	6.65E+03	7.405	6.017
1.00E+02	1.33E+02	1.33E+04	7.463	6.065
2.00E+02	2.66E+02	2.66E+04	7.548	6.097
5.00E+02	6.65E+02	6.65E+04	7.762	6.347
7.60E+02	1.01E+03	1.01E+05	8.255	6.783

## VPI Valve and CT-100 Speed Control Kit

---

Refer to the manuals in Table 1-5 for more details of CT-100 and inverter pump operation.

**Table 1-5 Related Instruction Manuals**

<b>Description</b>	<b>Model</b>	<b>Manual no.</b>
Gauge	CT-100	699908070
TriScroll 300 inverter pump	PTS03001INV XX	699904355
TriScroll 600 inverter pump	PTS06001INV XX	699904360
VPI kit	VPI XX INV24DC	699912117



## Vacuum Products Division Instructions for returning products

Dear Customer:

Please follow these instructions whenever one of our products needs to be returned.

- 1) Complete the attached Request for Return form and send it to Agilent Technologies (see below), taking particular care to identify all products that have pumped or been exposed to any toxic or hazardous materials.
- 2) After evaluating the information, Agilent Technologies will provide you with a Return Authorization (RA) number via email or fax, as requested.  
**Note:** Depending on the type of return, a Purchase Order may be required at the time the Request for Return is submitted. We will quote any necessary services (evaluation, repair, special cleaning, eg).
- 3) **Important steps for the shipment of returning product:**
  - Remove all accessories from the core product (e.g. inlet screens, vent valves).
  - Prior to shipment, drain any oils or other liquids, purge or flush all gasses, and wipe off any excess residue.
  - If ordering an Advance Exchange product, **please use the packaging from the Advance Exchange to return the defective product.**
  - Seal the product in a plastic bag, and package product carefully to avoid damage in transit. You are responsible for loss or damage in transit.
  - Agilent Technologies is not responsible for returning customer provided packaging or containers.
  - **Clearly label package with RA number.** Using the shipping label provided will ensure the proper address and RA number are on the package. Packages shipped to Agilent without a RA clearly written on the outside cannot be accepted and will be returned.
- 4) Return only products for which the RA was issued.
- 5) **Product being returned under a RA must be received within 15 business days.**
- 6) **Ship to the location specified on the printable label, which will be sent, along with the RA number, as soon as we have received all of the required information.** Customer is responsible for freight charges on returning product.
- 7) Return shipments must comply with all applicable **Shipping Regulations** (IATA, DOT, etc.) and carrier requirements.

RETURN THE COMPLETED **REQUEST FOR RETURN** FORM TO YOUR NEAREST LOCATION:

**EUROPE:**

Fax: 00 39 011 9979 330  
Fax Free: 00 800 345 345 00  
Toll Free: 00 800 234 234 00  
[vpt-customer@agilent.com](mailto:vpt-customer@agilent.com)

**NORTH AMERICA:**

Fax: 1 781 860 9252  
Toll Free: 800 882 7426, Option 3  
[vpl-ra@agilent.com](mailto:vpl-ra@agilent.com)

**PACIFIC RIM:**

please visit our website for individual office information  
<http://www.agilent.com>



Please read important policy information on Page 3 that applies to all returns.

**1) CUSTOMER INFORMATION**

<b>Company Name:</b>		<b>Contact Name:</b>	
<b>Tel:</b>	<b>Email:</b>	<b>Fax:</b>	
<b>Customer Ship To:</b>		<b>Customer Bill To:</b>	
Europe only: <b>VAT reg. Number:</b>		USA/Canada only: <input type="checkbox"/> <b>Taxable</b> <input type="checkbox"/> <b>Non-taxable</b>	

**2) PRODUCT IDENTIFICATION**

Product Description	Agilent P/N	Agilent S/N	Original Purchasing Reference

**3) TYPE OF RETURN** (Choose one from each row and supply Purchase Order if requesting a billable service)

- 3A.  Non-Billable  Billable **➔** New PO # (hard copy must be submitted with this form):
- 3B.  Exchange  Repair  Upgrade  Consignment/Demo  Calibration  Evaluation  Return for Credit

**4) HEALTH and SAFETY CERTIFICATION**

**AGILENT TECHNOLOGIES CANNOT ACCEPT ANY PRODUCTS CONTAMINATED WITH BIOLOGICAL OR EXPLOSIVE HAZARDS, RADIOACTIVE MATERIAL, OR MERCURY AT ITS FACILITY.**  
**Call Agilent Technologies to discuss alternatives if this requirement presents a problem.**

**The equipment listed above (check one):**

**HAS NOT** pumped or been exposed to any toxic or hazardous materials. OR

**HAS** pumped or been exposed to the following toxic or hazardous materials. If this box is checked, the following information must also be filled out. Check boxes for all materials to which product(s) pumped or was exposed:

Toxic  Corrosive  Reactive  Flammable  Explosive  Biological  Radioactive

**List all toxic/hazardous materials. Include product name, chemical name, and chemical symbol or formula:**

---

**NOTE:** If a product is received at Agilent which is contaminated with a toxic or hazardous material that was not disclosed, **the customer will be held responsible** for all costs incurred to ensure the safe handling of the product, and **is liable** for any harm or injury to Agilent employees as well as to any third party occurring as a result of exposure to toxic or hazardous materials present in the product.

**Print Name:** \_\_\_\_\_ **Authorized Signature:** ..... **Date:** \_\_\_\_\_

**5) FAILURE INFORMATION:**

Failure Mode (REQUIRED FIELD. See next page for suggestions of failure terms):
Detailed Description of Malfunction: (Please provide the error message)
Application (system and model):

<b>I understand and agree to the terms of Section 6, Page 3/3.</b>		
<b>Print Name:</b>	<b>Authorized Signature:</b> .....	<b>Date:</b>



**Vacuum Products Division  
Request for Return Form  
(Health and Safety Certification)**

Please use these Failure Mode to describe the concern about the product on Page 2.

**TURBO PUMPS and TURBO CONTROLLERS**

APPARENT DEFECT/MALFUNCTION	POSITION	PARAMETERS
- Does not start - Does not spin freely - Does not reach full speed - Mechanical Contact - Cooling defective	- Noise - Vibrations - Leak - Overtemperature - Clogging	- Vertical - Horizontal - Upside-down - Other: ..... Power:                      Rotational Speed: Current:                    Inlet Pressure: Temp 1:                    Foreline Pressure: Temp 2:                    Purge flow: OPERATING TIME:

**ION PUMPS/CONTROLLERS**

- Bad feedthrough	- Poor vacuum
- Vacuum leak	- High voltage problem
- Error code on display	- Other

**VALVES/COMPONENTS**

- Main seal leak	- Bellows leak
- Solenoid failure	- Damaged flange
- Damaged sealing area	- Other

**LEAK DETECTORS**

- Cannot calibrate	- No zero/high background
- Vacuum system unstable	- Cannot reach test mode
- Failed to start	- Other

**INSTRUMENTS**

- Gauge tube not working	- Display problem
- Communication failure	- Degas not working
- Error code on display	- Other

**SCROLL AND ROTARY VANE PUMPS**

- Pump doesn't start	- Noisy pump (describe)
- Doesn't reach vacuum	- Over temperature
- Pump seized	- Other

**DIFFUSION PUMPS**

- Heater failure	- Electrical problem
- Doesn't reach vacuum	- Cooling coil damage
- Vacuum leak	- Other

Section 6) **ADDITIONAL TERMS**

**Please read the terms and conditions below as they apply to all returns and are in addition to the Agilent Technologies Vacuum Product Division – Products and Services Terms of Sale.**

- Customer is responsible for the freight charges for the returning product. Return shipments must comply with all applicable **Shipping Regulations** (IATA, DOT, etc.) and carrier requirements.
- Customers receiving an Advance Exchange product agree to return the defective, rebuildable part to Agilent Technologies **within 15 business days**. Failure to do so, or returning a non-rebuildable part (crashed), will result in an invoice for the non-returned/non-rebuildable part.
- Returns for credit toward the purchase of new or refurbished Products are subject to prior Agilent approval and may incur a restocking fee. Please reference the original purchase order number.
- Units returned for evaluation will be evaluated, and a quote for repair will be issued. If you choose to have the unit repaired, the cost of the evaluation will be deducted from the final repair pricing. A Purchase Order for the final repair price should be issued within 3 weeks of quotation date. Units without a Purchase Order for repair will be returned to the customer, and the evaluation fee will be invoiced.
- A Special Cleaning fee will apply to all exposed products per Section 4 of this document.
- If requesting a calibration service, units must be functionally capable of being calibrated.

## VPI Valve and CT-100 Speed Control Kit

---

*This page intentionally left blank.*



# Agilent Technologies

## Vacuum Product Division

### United States & Canada

*Agilent Technologies*  
*Vacuum Products Division*  
121 Hartwell Avenue  
Lexington, MA 02421 USA  
Tel: +1 781 861 7200  
Toll-Free: +1 800 882 7426  
Fax: +1 871 860 5437

### Benelux

*Agilent Technologies*  
*Vacuum Products Division*  
Herculesweg 8  
4338 PL Middelburg  
THE NETHERLANDS  
Tel: +31 118 671570  
Fax: +31 118 671569

### China

*Agilent Technologies*  
*Vacuum Products Division*  
Room 1648  
Central Tower South Wing  
Beijing Junefield Plaza  
No. 10 XuanWuMenWai Street  
Beijing 100052 P.R. CHINA  
Tel.: +86 (10) 6310 8550  
Toll-Free: 800 820 6556  
Fax: +86 (10) 6310 0141

### France

*Agilent Technologies*  
*Vacuum Products Division*  
7 avenue des Tropiques  
Z.A. de Courtaboeuf - B.P. 12  
91941 Les Ulis cedex FRANCE  
Tel.: +33 (0) 1 69 86 38 84  
Fax: +33 (0) 1 69 86 29 88

### Germany & Austria

*Agilent Technologies*  
*Vacuum Products Division*  
Alsfelder Strasse 6  
Postfach 11 14 35  
64289 Darmstadt GERMANY  
Tel.: +49 (0) 6151 703 353  
Fax: +49 (0) 6151 703 302

### India

*Agilent Technologies*  
*Vacuum Product Division*  
205-A, "A" wing of Galleria,  
2nd floor, Hiranandani Gardens,  
Powai, Mumbai-400 076, India  
Tel.: +91 22-2570 8595 / 8597  
Fax: +91 22- 2570 8599

### Italy

*Agilent Technologies*  
*Vacuum Products Division*  
via F.lli Varian 54  
10040 Leini, (Torino) ITALY  
Tel.: +39 011 997 9111  
Toll-Free: 00 800 234 234 00  
Fax: +39 011 997 9350

### Japan

*Agilent Technologies*  
*Vacuum Products Division*  
Sumitomo Shibaura Building 4-16-36  
8th Floor  
4-16-36 Shibaura Minato-ku  
Tokyo 108 JAPAN  
Tel.: +81 3 5232 1253  
Toll-Free: 0120 655 040  
Fax: +81 3 5232 1710

### Korea

*Agilent Technologies*  
*Vacuum Products Division*  
Shinsa 2nd Bldg. 2F 966-5  
Daechi-dong  
Kangnam-gu, Seoul  
KOREA 135-280  
Tel.: +82 2 3452 2452  
Toll-Free: 080 222 2452  
Fax: +82 2 3452 2451

### Mexico

*Agilent Technologies*  
*Vacuum Products Division*  
Concepcion Beistegui No 109  
Col Del Valle C.P. 03100  
MEXICO, D.F.  
Tel.: +52 5 523 9465  
Fax: +52 5 523 9472

### Southeast Asia

*Agilent Technologies*  
*Vacuum Products Division*  
South East Asia (SEA) - Alex Ho  
H/P: +601 2213 1253  
Fax: +603 6733 8121

### Singapore

*Agilent Technologies*  
*Vacuum Products Division*  
Singapore  
Unit 10-04 Helios  
Biopolis @ one-north  
11 Biopolis Way, 138667  
Singapore  
H/P: +65 92364988  
Fax: +65 64789603

### Taiwan

*Agilent Technologies*  
*Vacuum Products Division*  
14F-6, No. 77, Hsin Tai Wu Road,  
Sec. 1  
Hsi chih, Taipei Hsien, Taiwan,  
R.O.C.  
Tel.: +886 2 2698 9555  
Toll Free: 0800 051 342  
Fax: +886 2 2698 9678

### UK & Ireland

*Agilent Technologies*  
*Vacuum Products Division*  
6 Mead Road  
Oxford Industrial Park  
Tel.: +44 (0) 1865 291570  
Fax: +44 (0) 1865 291571



**Agilent Technologies**