

IPF 25

FILTRE D'ASPIRATION DES POMPES ACP 15 - ACP 28
INLET PARTICLES FILTER FOR ACP 15 - ACP 28 PUMPS

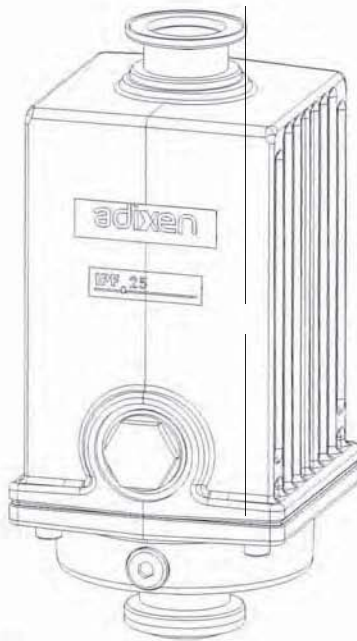

Manuel de l'Utilisateur User's Manual

adixen
by Alcatel Vacuum Technology



PLEASE NOTE: We do sell the related products within this literature but we are not connected in any way with the manufacture of your product. We provide this literature for the products we sell and service. They are intended to provide users with the manufactures instructions to operate the equipment in a safe manner.

www.idealvac.com

II. INLET PARTICLES FILTER

II.1. DESCRIPTION

The IPF 25 filter is installed on the inlet of a ACP15 or ACP28 pump which handles dust or particle-laden gases (vacuum packing, metallurgy, lamp manufacture, evaporation, etc.).

This filter collects particles with a diameter greater than 25 microns, and thus protects the pumping system without any appreciable pressure drop.

This accessory is designed for the pumping of not very corrosive gases: **it is therefore not recommended for use in microelectronic applications nor during pumping of condensable or polymerizable products.**

WARNING

Filter cartridges are flammable : do not use eliminators when pumping flammable products such as oxygen or silane.

II.2. CHARACTERISTICS

- Part number: 111649 (Model IPF 25)
- Weight: 2.644 lbs
- Connection: DN25 ISO-KF
- Material: Body : aluminium
Glass microfiber and epoxy binder cartridge
- Tightness: 1.10^{-6} atm.cm³.s⁻¹
- Connection to pump: Nipple marked «**pump ↓**»
- Inlet pressure (mbar): **see appendix 1**
- Conductance (m3/h): **see appendix 1**
- Dimensions: **see Figure c)**

LIVRE AVEC	REPERE	REFERENCE *
1 centering ring DN25 ISO-KF	B	068224
1 O-ring DN25 ISO-KF	C	079238
1 quick connect clamp DN25 ISO-KF	D	083264

II.3. ASSEMBLY

As a general rule, accessories whose **tightness and materials are compatible with the pumped gases and the required safety conditions** must be used upstream and downstream of the trap.

The filter is mounted on the inlet port located vertically on the pump. Proceed as follows:

- Assemble according to **Figure a) or figure b)** using the connection accessories provided with the filter.
- Ensure that the «**Pump ↓**» label points to the side of the nipple connected to the pump.

The filter is designed for use in any orientation. Care should simply be taken to avoid creating a throttling or low pressure point upstream of the filter which may cause particles to collect by gravity: this will reduce pumping speeds but will not however clog the cartridge.

IPF 25

II.4. MAINTENANCE

WARNING

Each time the system is dismantled, take all necessary precautions to ensure safety and protection of personnel against possible toxicity, corrosion, and radioactivity of residues. Depending on the nature of the residue, we recommend:

- Purging the system with dry nitrogen before working on it.
- Wearing gloves, goggles and, if necessary, an oxygen mask.
- Thorough ventilation of the room and disassembly under a fume hood.
- Recovery of residue in appropriate containers. If necessary, have them destroyed by a competent organization.

a) Cartridge saturation

A reduction in pumping speed indicates filter clogging. In this condition, the cartridge causes a pressure drop which varies according to the degree of contamination. It is then necessary to replace the cartridge and clean the filter.

CAUTION

Prior to performing any work on the filter, ensure that the pump is stopped and that the filter is at atmospheric pressure.

b) Disassembly (Figure d)

- Detach the filter from the pump and disassemble on a workbench.
- Unscrew the assembling screw 22: the filter cartridge 21 stays on the base 2, replace it.
- Remove the o-ring 9 from the base.
- Remove the equipped valve seat from the body 1.
- Unscrew the assembling screw 17 and remove the washer 15, the valve 16.

c) Cleaning

CAUTION

Never clean the filter cartridge: always install a new one.

Elastomer seal 9 must always be replaced by new one.

d) Reassembly

- Install the washer 15 on a new valve 16.
- Position on the valve seat 14 the valve and its washer; **the valve flat face must rest on the valve seat.**
- Install the spring 20 on the washer, then assemble the ressort support 18 with screws 17.
- Install a new, O-ring in the body 2.
- Position a new cartridge 21 in the body 2.
- Center the equipped valve seat on the cartridge.
- Assemble the body 1 and secure with the mounting screws 22 and 23.
- Connect the filter to the pump inlet port.

II.5. SPARE PARTS

Parts to be replaced each time the filter is dismantled to change the cartridge:

REFERENCE	NUMBER	PART NAME	PART NUMBER
21	1	Filter cartridge	111650
16	1	Diaphragm	054196
9	1	O-ring	083539

FIGURES

Montage du filtre IPF 25 sur pompe ACP 15
Assembling IPF 25 filter on ACP 15 pump

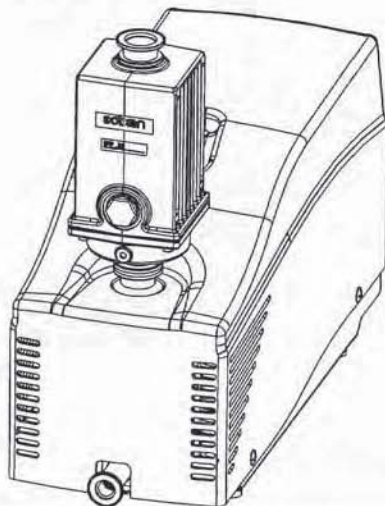

Figure a)

Montage du filtre IPF 25 sur pompe ACP 28
Assembling IPF 25 filter on ACP 28 pump

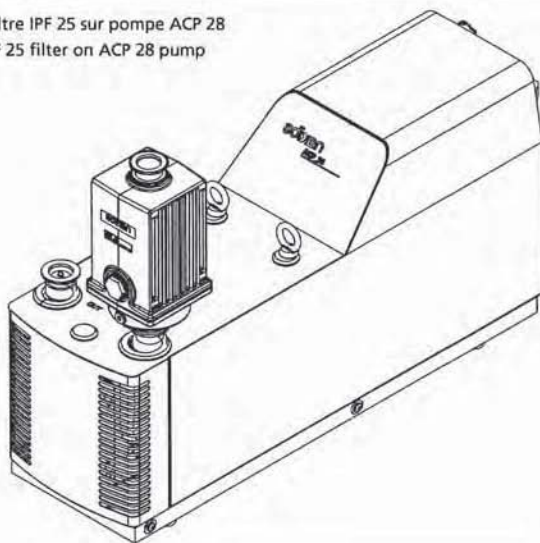
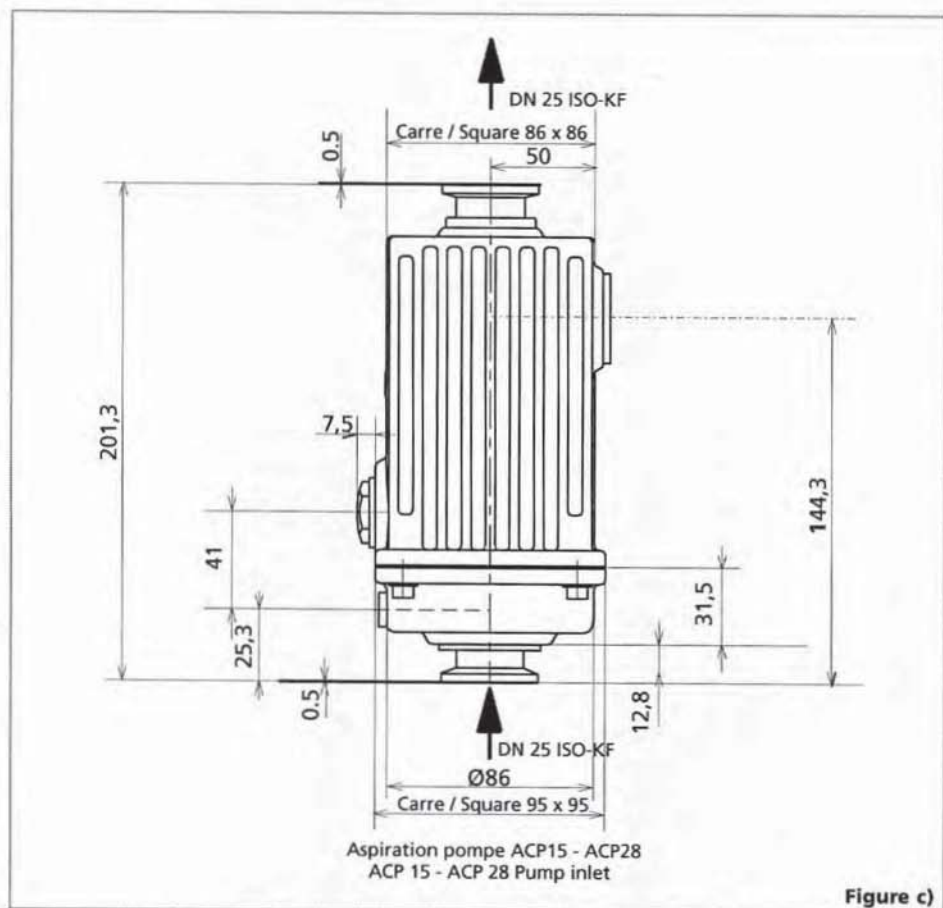
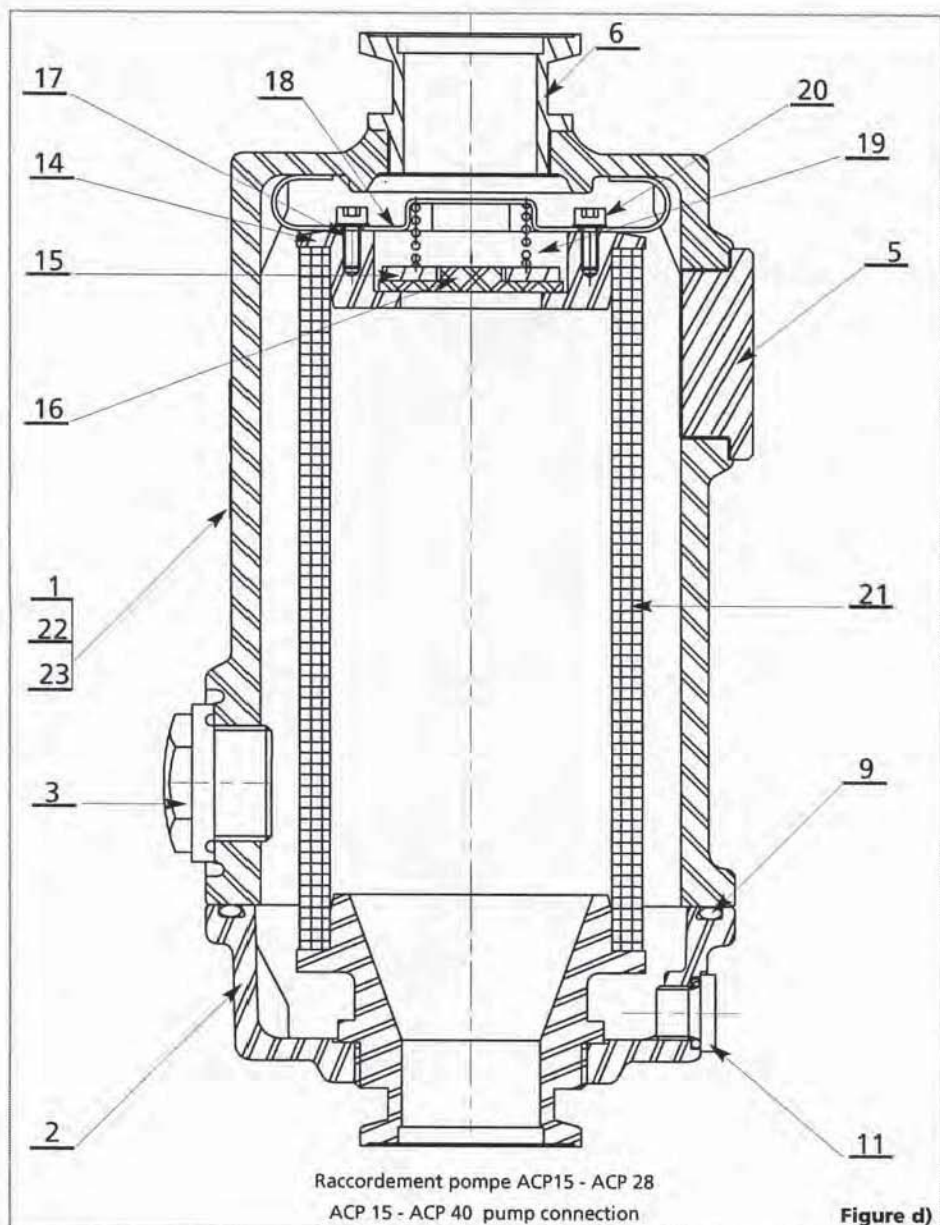

Figure b)



IPF 25



NOMENCLATURE IPF 25

REPÈRE REF.	DESIGNATION MATIERE	DESCRIPTION MATERIAL	QUANTITE QUANTITY
1	Corps du séparateur <i>aluminium</i>	Body <i>aluminium</i>	1
2	Corps inférieur <i>aluminium</i>	Base of the separator <i>aluminium</i>	1
3	Voyant de niveau + joint <i>polyamide + élastomère NBR*</i>	Sight glass + O-ring <i>polyamid + elastomer NBR*</i>	1
5	Obtrateur <i>aluminium</i>	Blank off flange <i>aluminium</i>	1
6	Embout <i>aluminium</i>	Nipple <i>aluminium</i>	1
9	Joint torique NBR <i>élastomère NBR*</i>	O-ring <i>elastomer NBR*</i>	1
11	Bouchon 1/8 + Joint torique <i>Aluminium + NBR</i>	Plug 1/8 + O-ring <i>Aluminium +NBR</i>	1
14	Support soupape <i>aluminium</i>	Valve seat <i>aluminium</i>	1
15	Rondelle <i>acier inoxydable</i>	Washer <i>stainless steel</i>	1
16	Soupape <i>élastomère FPM*</i>	Valve <i>elastomer FPM*</i>	1
17	Vis CHC M 8 x 3 <i>acier</i>	Screw CHC M8 x 3 <i>steel</i>	2
18	Ressort support <i>acier</i>	Spring <i>steel</i>	1
19	Ressort <i>acier</i>	Spring <i>steel</i>	1
20	Rondelle <i>acier</i>	Washer <i>steel</i>	2
21	Cartouche <i>époxy + fibre de verre</i>	Cartridge <i>epoxy binder+ glass microfibers</i>	1
22	Vis CHC M 5 x16 <i>acier</i>	Screw CHC 5 x16 <i>steel</i>	4
23	Rondelle <i>acier</i>	Washer <i>steel</i>	4

* suivant norme NFT 40-002/ following norme NFT 40-002.

COURBES DE POMPAGE / PUMPING CURVES

