



VARIAN 
vacuum technologies

Turbo-V 1000 ICE pump

**Model 969-9080
Model 969-9100**

MANUALE DI ISTRUZIONI

BEDIENUNGSHANDBUCH

NOTICE DE MODE D'EMPLOI

MANUAL DE INSTRUCCIONES

MANUAL DE INSTRUÇÕES

BEDRIJFSHANDLEIDING

INSTRUKSTIONSBOG

BRUKSANVISNING

INSTRUKSJON MANUAL

OHJEKÄSIKIRJA

ΟΔΗΓΙΕΣ ΧΡΗΣΕΩΣ

INSTRUCTION MANUAL

Turbo-V 1000 ICE



VARIAN



vacuum technologies

Dear Customer,

Thank you for purchasing a VARIAN vacuum product. At VARIAN Vacuum Technologies we make every effort to ensure that you will be satisfied with the product and/or service you have purchased.

As part of our Continuous Improvement effort, we ask that you report to us any problem you may have had with the purchase or operation of our product. On the back side you find a Corrective Action Request form that you may fill out in the first part and return to us.

This form is intended to supplement normal lines of communications and to resolve problems that existing systems are not addressing in an adequate or timely manner.

Upon receipt of your Corrective Action Request we will determine the Root Cause of the problem and take the necessary actions to eliminate it. You will be contacted by one of our employees who will review the problem with you and update you, with the second part of the same form, on our actions.

Your business is very important to us. Please, take the time and let us know how we can improve.

Sincerely,

Sergio PIRAS

*Vice President and General Manager
VARIAN Vacuum Technologies*

Note: Fax or mail the Customer Request for Action (see backside page) to VARIAN Vacuum Technologies (Torino) - Quality Assurance or to your nearest VARIAN representative for onward transmission to the same address.

CUSTOMER REQUEST FOR CORRECTIVE / PREVENTIVE / IMPROVEMENT ACTION

TO : VARIAN VACUUM TECHNOLOGIES TORINO - QUALITY ASSURANCE

FAX N° : XXXX - 011 - 9979350

ADDRESS: VARIAN S.p.A. - Via F.lli Varian, 54 - 10040 Leinì (Torino) - Italy

E-MAIL : marco.marzio@varianinc.com

NAME _____	COMPANY _____	FUNCTION _____
<p>ADDRESS : _____</p> <p>TEL. N° : _____ FAX N° : _____</p> <p>E-MAIL : _____</p>		
<p>PROBLEM / SUGGESTION :</p> <p>_____</p> <p>_____</p> <p>_____</p> <p>_____</p>		
<p>REFERENCE INFORMATION (model n°, serial n°, ordering information, time to failure after installation, etc.) :</p> <p>_____</p> <p>_____</p> <p>_____</p> <p style="text-align: right;">DATE _____</p>		

<p>CORRECTIVE ACTION PLAN / ACTUATION (by VARIAN VTT)</p> <p>_____</p> <p>_____</p> <p>_____</p> <p>_____</p> <p>_____</p>	<p>LOG N° _____</p>
--	---------------------

XXXX = Code for dialing Italy from your country (es. 01139 from USA; 00139 from Japan, etc.)



ISTRUZIONI PER L'USO	1
GEBRAUCHSANLEITUNG	3
MODE D'EMPLOI	5
INSTRUCCIONES DE USO	7
INSTRUÇÕES PARA O USO	9
GEBRUIKSAANWIJZINGEN	11
BRUGSANVISNING	13
BRUKSANVISNING.....	15
BRUKERVEILEDNING	17
KÄYTTÖOHJEET	19
ΠΑΡΗΓΓΙΕΣ ΧΡΗΣΕΩΣ	21
INSTRUCTIONS FOR USE	23
TECHNICAL INFORMATION	25
DESCRIPTION OF THE TURBOPUMP	25
TECHNICAL SPECIFICATION	26
INLET SCREEN INSTALLATION	28
HEATING JACKET INSTALLATION.....	28
WATER COOLING KIT INSTALLATION	29
VENT DEVICE INSTALLATION	30
VENT VALVE INSTALLATION	30
SOLID STATE FLOWMETER INSTALLATION.....	31
PUMP USED WITH CORROSIVE GASES	31
TYPICAL LAYOUT DIAGRAM.....	32
Connection A - HIGH VACUUM FLANGE.....	32
Connection configurations	33
Connection B - FORE-VACUUM PUMP.....	33
Connection C - ELECTRICAL.....	33
SUGGESTED PUMP INSTALLATION	34
ROUGHING OPERATION	34
Pump and chamber at atmosphere	34
Pump under vacuum, chamber at atmosphere (chamber cleaning)	34
PUMP USED IN PRESENCE OF MAGNETIC FIELDS	35
ACCESSORIES	35

INFORMAZIONI GENERALI

Questa apparecchiatura è destinata ad uso professionale. L'utilizzatore deve leggere attentamente il presente manuale di istruzioni ed ogni altra informazione aggiuntiva fornita dalla Varian prima dell'utilizzo dell'apparecchiatura. La Varian si ritiene sollevata da eventuali responsabilità dovute all'inosservanza totale o parziale delle istruzioni, ad uso improprio da parte di personale non addestrato, ad interventi non autorizzati o ad uso contrario alle normative nazionali specifiche.

Le pompe della serie Turbo-V1000 ICE sono pompe turbomolecolari per applicazioni di alto e ultra alto vuoto particolarmente adatte per l'uso nei settori legati all'industria dei semiconduttori, e sono capaci di pompare qualsiasi tipo di gas o di composto gassoso. Non sono adatte per il pompaggio di liquidi o di particelle solide.

L'effetto pompante è ottenuto tramite una turbina rotante ad elevata velocità (38000 giri/min. max) mossa da un motore elettrico trifase ad alto rendimento. Le pompe Turbo-V1000 ICE sono totalmente prive di agenti contaminanti, e sono quindi adatte per applicazioni che richiedono un vuoto "pulito".

Nei paragrafi seguenti sono riportati durante l'utilizzo dell'apparecchiatura. Informazioni dettagliate sono fornite nell'appendice "Technical information".

Questo manuale utilizza le seguenti convenzioni:



PERICOLO!

I messaggi di pericolo attirano l'attenzione dell'operatore su una procedura o una pratica specifica che, se non eseguita in modo corretto, potrebbe provocare gravi lesioni personali.



ATTENZIONE!

I messaggi di attenzione sono visualizzati prima di procedure che, se non osservate, potrebbero causare danni all'apparecchiatura.

NOTA

Le note contengono informazioni importanti estrapolate dal testo.

IMMAGAZZINAMENTO

Durante il trasporto e l'immagazzinamento delle pompe non devono essere superate le seguenti condizioni ambientali:

- temperatura: da -20 °C a +70 °C
- umidità relativa: 0 - 95% (non condensante)

Se il tempo di immagazzinamento è molto lungo, avviare la pompa nel modo SOFT START (vedere il manuale del controller).

PREPARAZIONE PER L'INSTALLAZIONE

La pompa viene fornita in un imballo protettivo speciale; se si presentano segni di danni, che potrebbero essersi verificati durante il trasporto, contattare l'ufficio vendite locale.

Durante l'operazione di disimballaggio, prestare particolare attenzione a non lasciar cadere la pompa e a non sottoporla ad urti o vibrazioni.

Non disperdere l'imballo nell'ambiente. Il materiale è completamente riciclabile e risponde alla direttiva CEE 85/399 per la tutela dell'ambiente.



ATTENZIONE!

Onde evitare problemi di degassamento, non toccare con le mani nude i componenti destinati ad essere esposti al vuoto. Utilizzare sempre i guanti o altra protezione adeguata.

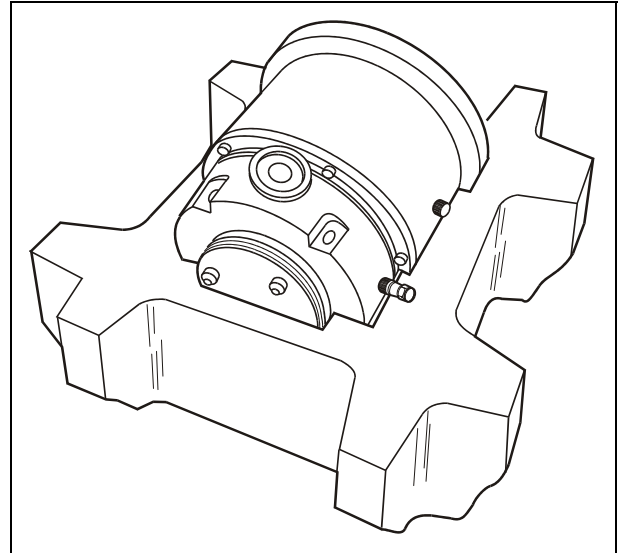

NOTA

La pompa non può essere danneggiata rimanendo semplicemente esposta all'atmosfera. Si consiglia comunque di mantenerla chiusa fino al momento dell'installazione sul sistema onde evitare eventuale inquinamento da polvere.

INSTALLAZIONE



PERICOLO!

La pompa, a causa del suo peso, deve essere maneggiata tramite appositi attrezzi di sollevamento e spostamento.

Non installare e/o utilizzare la pompa in ambienti esposti ad agenti atmosferici (pioggia, gelo, neve), polveri, gas aggressivi, in ambienti esplosivi o con elevato rischio di incendio.

Durante il funzionamento è necessario che siano rispettate le seguenti condizioni ambientali:

- pressione massima: 2 bar oltre la pressione atmosferica
- temperatura: da + 5 °C a +35 °C
- umidità relativa: 0 - 95% (non condensante).



ATTENZIONE!

Staccare l'adesivo e togliere il tappo di protezione solo al momento del collegamento della turbopompa al sistema.

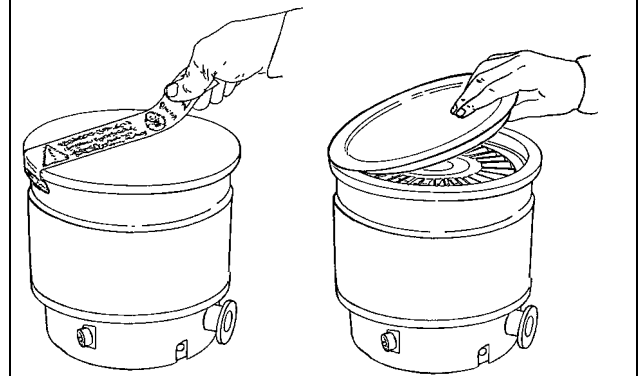



In presenza di campi elettromagnetici la pompa deve essere protetta tramite opportuni schermi. Vedere l'appendice "Technical Information" per ulteriori dettagli.

Le pompe turbomolecolari della serie Turbo-V1000 ICE devono essere utilizzate solo con uno degli appositi controllori Varian (serie 969-9447, 969-9547) e devono essere collegate ad una pompa primaria (vedere schema in "Technical Information").

La turbopompa può essere installata in qualsiasi posizione.

Fissare la turbopompa in posizione stabile collegando la flangia di ingresso della turbopompa ad una controflangia fissa capace di resistere ad una coppia di 4668 Nm attorno al proprio asse.

La turbopompa con flangia di ingresso ISO deve essere fissata alla camera da vuoto per mezzo di morsetti doppi o morsetti singoli. La seguente tabella descrive il numero di morsetti necessari e con quale coppia di serraggio stringerli.

FLANGIA	TIPO DI MORSETTO	N.	COPIA DI SERRAGGIO
ISO 200	Morsetto doppio con filettatura M10	6	23 Nm
	Morsetto singolo con filettatura M10	6	23 Nm

La turbopompa con flangia di ingresso ConFlat deve essere fissata alla camera da vuoto per mezzo dell'apposita minuteria meccanica Varian.

Per fissare la pompa per mezzo della sua base, è necessario utilizzare tre viti M6 fissate agli appositi fori presenti sulla base della pompa. Le viti utilizzate devono avere un carico di snervamento di 550 N/mm² e devono essere fissate con una coppia di 4,5 Nm.

Per l'installazione degli accessori opzionali, vedere "Technical Information".

USO

Tutte le istruzioni per il corretto funzionamento della turbopompa sono contenute nel manuale dell'unità di controllo. Leggere attentamente tale manuale prima dell'utilizzo.

Per raggiungere migliori pressioni limite è possibile riscaldare l'involucro della pompa utilizzando il riscaldatore opzionale.

Durante l'eventuale riscaldamento della camera da vuoto, la temperatura sulla flangia di ingresso non deve essere superiore a 120 °C.

Utilizzare sempre il raffreddamento ad acqua durante le operazioni di riscaldamento.

! PERICOLO!

Non toccare la turbopompa e i suoi eventuali accessori durante le operazioni di riscaldamento. L'elevata temperatura può causare lesioni alle persone.

! ATTENZIONE!

Per la mandata all'aria della pompa utilizzare aria o gas inerte esente da polvere o particelle. La pressione di ingresso attraverso l'apposita porta deve essere inferiore a 2 bar (oltre la pressione atmosferica).

! ATTENZIONE!

Evitare urti, oscillazioni o bruschi spostamenti della turbopompa quando è in funzione. I cuscinetti potrebbero danneggiarsi.

! ATTENZIONE!

Per il pompaggio di gas aggressivi queste pompe sono dotate di una apposita porta attraverso la quale è necessario fornire alla pompa un flusso di gas inerte (Azoto o Argon) per proteggere i cuscinetti (vedere l'appendice "Technical Information").

! PERICOLO!

Quando la pompa viene utilizzata per il pompaggio di gas tossici, infiammabili o radioattivi, seguire le appropriate procedure tipiche di ciascun gas.

Non usare la pompa in presenza di gas esplosivi.

MANUTENZIONE

Le pompe della serie Turbo-V1000 ICE non richiedono alcuna manutenzione. Qualsiasi intervento deve essere eseguito da personale autorizzato.

! PERICOLO!

Prima di effettuare qualsiasi intervento sulla turbopompa scollegare il connettore di alimentazione, mandare all'aria la pompa aprendo l'apposita valvola, attendere fino al completo arresto del rotore ed attendere che la temperatura superficiale della pompa sia inferiore a 50°C.

In caso di guasto è possibile usufruire del servizio di riparazione Varian o del "Varian advanced exchange service", che permette di ottenere una pompa rigenerata in sostituzione di quella guasta.

NOTA

Prima di rispedire al costruttore una pompa per riparazioni o advanced exchange service, è indispensabile compilare e far pervenire al locale ufficio vendite la scheda "Sicurezza e Salute" allegata al presente manuale di istruzioni. Copia della stessa deve essere inserita nell'imballo della pompa prima della spedizione.

Qualora una pompa dovesse essere rottamata, procedere alla sua eliminazione nel rispetto delle normative nazionali specifiche.

ALLGEMEINES

Dieser Apparat ist für Fachbetriebe bestimmt. Vor Gebrauch sollte der Benutzer dieses Handbuch sowie alle weiteren mitgelieferten Zusatzdokumentationen genau lesen. Bei Nichtbeachtung -auch teilweise- der enthaltenen Hinweise, unsachgemäßem Gebrauch durch ungeschultes Personal, nicht autorisierten Eingriffen und Mißachtung der einheimischen, hier zur Geltung kommenden Bestimmungen übernimmt die Firma Varian keinerlei Haftung.

Bei den Pumpen der Serie Turbo-V1000 ICE handelt es sich um Turbomolekularpumpen für Hoch- und Ultrahochvakuumanwendungen. Sie eignen sich insbesondere für den Einsatz in den verschiedenen Gebieten der Halbleiterindustrie und zur Förderung von jeder Art von Gasen oder gashaltigen Gemischen, nicht jedoch zur Förderung von Flüssigstoffen oder Festpartikel.

Die Pumpwirkung wird durch eine Hochgeschwindigkeitsdrehturbine (max. 38000 U/Min) erreicht, die von einem Hochleistungsdrehstrommotor angetrieben wird. Die Turbo-V1000 ICE-Pumpen enthalten keinerlei umweltschädliche Substanzen und eignen sich deshalb auch für Anwendungszwecke, die ein "sauberes" Vakuum vorschreiben

In den folgenden Abschnitten sind alle erforderlichen Informationen für die Sicherheit des Bedieners bei der Anwendung des Geräts aufgeführt. Detaillierte technische Informationen sind im Anhang "Technical Information" enthalten.

In dieser Gebrauchsanleitung werden Sicherheitshinweise folgendermaßen hervorgehoben:



GEFAHR!

Die Gefahrenhinweise lenken die Aufmerksamkeit des Bedieners auf eine spezielle Prozedur oder Praktik, die bei unkorrekter Ausführung schwere Verletzungen hervorrufen können.



ACHTUNG!

Die Warnhinweise vor bestimmten Prozeduren machen den Bediener darauf aufmerksam, daß bei Nichteinhaltung Schäden an der Anlage entstehen können.

ANMERKUNG

Die Anmerkungen enthalten wichtige Informationen, die aus dem Text hervorgehoben werden.

LAGERUNG

Beim Transport und bei der Lagerung der Pumpen müssen folgende klimatische Verhältnisse vorliegen:

- Temperatur: von -20°C bis +70°C
- Relative Luftfeuchtigkeit: 0 - 95% (nicht kondensierend).

Nach extrem langer Lagerung muß die Pumpe bei Inbetriebsetzung im SOFT START-Modus gestartet werden (siehe Handbuch der Steuereinheit).

VOR DER INSTALLATION

Die Pumpe wird mit einer speziellen Schutzverpackung geliefert. Eventuelle Transportschäden müssen der zuständigen örtlichen Verkaufsstelle gemeldet werden.

Beim Auspacken vorsichtig vorgehen, damit die Pumpe nicht fällt oder Stößen ausgesetzt wird.

Das Verpackungsmaterial muß korrekt entsorgt werden. Es ist vollständig recyclebar und entspricht der EG-Richtlinie 85/399 für Umweltschutz.



ACHTUNG!

Um Entgasungsprobleme zu vermeiden, dürfen die Komponenten, die in Berührung mit dem Vakuum kommen, nicht mit bloßen Händen angefaßt werden. Immer Handschuhe oder einen anderen geeigneten Schutz tragen.

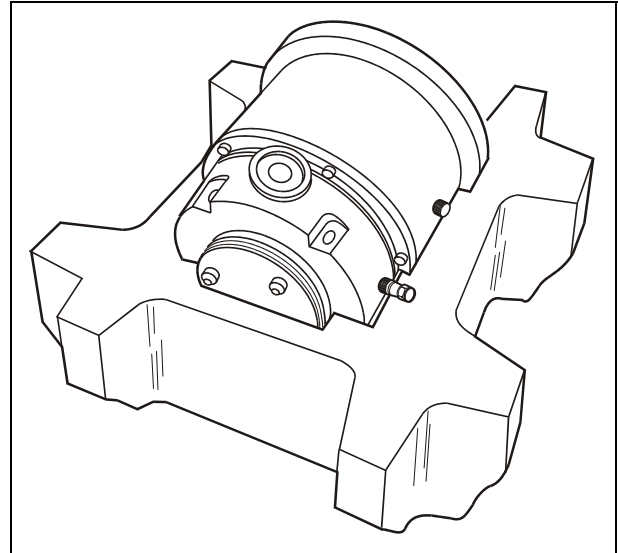

ANMERKUNG

Die Pumpe kann, wenn sie ganz einfach der Atmosphäre ausgesetzt ist, keine Schäden erleiden. Sie sollte jedoch bis zur Installation auf der Anlage geschlossen bleiben, um Staubverschmutzungen zu vermeiden.

INSTALLATION



GEFAHR!

Aufgrund ihres Gewichtes darf die Pumpe nur mit entsprechend geeigneten Geräten angehoben und transportiert werden.

Die Pumpe darf nicht in Umgebungen benutzt werden, die ungeschützt vor Wetter (Regen, Frost, Schnee), Staub und aggressiven Gasen sind, und in denen Explosions- und erhöhte Brandgefahr besteht.

Beim Betrieb müssen folgende Umgebungsbedingungen eingehalten werden:

- Maximaldruck: 2 Bar über dem atmosphärischen Druck
- Temperatur: von +5°C bis +35°C
- Relative Luftfeuchtigkeit: 0-95% (nicht kondensierend).



ACHTUNG!

Entfernen Sie die Klebefolie und den Schutzdeckel erst beim Anschluß der Turbopumpe an die Anlage.

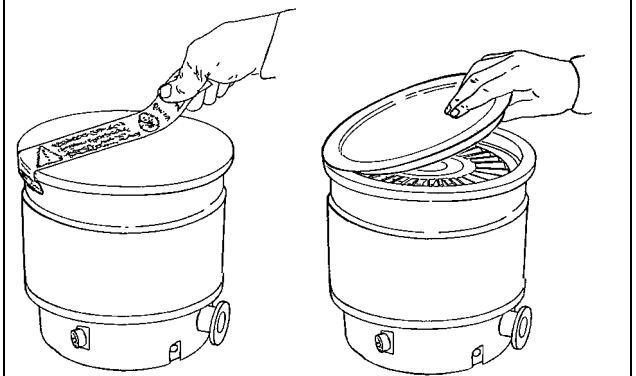



Sind Magnetfelder vorhanden, müssen die Pumpen über Einsatz eines entsprechend geeigneten Schutzschirms geschützt werden. Weitere Hinweise: siehe Anhang "Technical Information".

Die Turbomolekularpumpen der Serie Turbo-V1000 ICE dürfen nur mit einer der Varian-Spezial-Controller (Serie 969-9447, 969-9547) benutzt werden und müssen an eine Primärpumpe angeschlossen werden (siehe Schema in "Technical Information").

Die Turbopumpen können in jeder Position installiert werden. Installieren Sie die Pumpe in einer stabilen Position, indem Sie den Flansch am Eingang der Turbopumpe an einen festen Gegenflansch anschließen, der ein Drehmoment von 4668 Nm um seine eigene Achse aushält.

Turbopumpen mit einem ISO-Eingangsfansch müssen mittels doppelten oder einfachen Klemmschellen an die Vakuumkammer angeschlossen werden. In der nachstehenden Tabelle sind die Anzahl der Klemmschellen und der Anzugsmoment für die jeweiligen Flanschgrößen und Klemmenarten angegeben.

FLANSCH	KLEMMSCHELLE	AN.	ANZUGSMOMENT
ISO 200	Doppelklemme mit M10-Gewinde	6	23 Nm
	Einzelschelle mit M10-Gewinde	6	23 Nm

Wenn die Pumpen über ihr Unterteil installiert werden sollen, müssen in die Bohrungen des Unterteils 3 M6-Schrauben eingesetzt werden. Die Schrauben müssen eine Dehngrenze von 550 N/mm² haben und mit einem Anzugsmoment 4,5 Nm angezogen werden. Installation Sonderzubehör: siehe "Technical Information".

ANWENDUNG

Sämtliche Hinweise für den korrekten Betrieb der Turbopumpe sind im Handbuch der Steuereinheit enthalten.

Dieses Handbuch sollte vor der Inbetriebnahme genau gelesen werden.

Um einen optimalen Enddruck zu erhalten, kann das Pumpengehäuse mit einer Heizmanschette (Optional) ausgeheizt werden. Damit die Flanschgrenztemperatur der Turbopumpe 120°C nicht überschreitet, sollte immer bei ausheizbaren Vakuumsystemen die TP mit Wasserkühlung arbeiten.

GEFAHR!

Während des Ausheizens dürfen weder die Pumpe noch eventuelle heiße Anschlußteile berührt werden, denn es besteht Verbrennungsgefahr.

ACHTUNG!

Für die Belüftung der Pumpe trockene staub- und partikelfreie Luft, oder Edelgase verwenden. Der Eingangsdruck am Belüftungsanschluß muß kleiner als 2 bar über dem atmosphärischen Druck sein.

ACHTUNG!

Während des Betriebs sind Stoß- und Vibrationseinwirkungen sowie Ruckbewegungen an der Turbopumpe zu vermeiden, da die Lager beschädigt werden könnten.

ACHTUNG!

Zum Pumpen von aggressiven Gasen sind die Pumpen mit einer Öffnungsklappe ausgestattet, über die zum Schutz der Lager ausschließlich Edelgas (Stickstoff oder Argon) zugeführt werden darf (siehe Anhang "Technical Information").

GEFAHR!

Wenn die Pumpe zur Förderung von giftigen, leicht entflammaren oder radioaktiven Gasen benutzt wird, müssen die für das jeweilige Gas vorgeschriebenen Vorgänge und Maßnahmen befolgt werden.

Benutzen Sie die Pumpe niemals in Präsenz von explosiven Gasen.

WARTUNG

Die Pumpen der Serie Turbo-V1000 ICE sind wartungsfrei. Eventuelle Eingriffe dürfen nur von autorisiertem Fachpersonal ausgeführt werden.

GEFAHR!

Vor jedem Eingriff an der Turbopumpe den Netzstecker ziehen, die Pumpe über Öffnung des entsprechenden Ventils belüften, warten bis der Rotor vollkommen stillsteht und die Temperatur am Pumpengehäuse unter 50°C abgesunken ist.

Bei einem Defekt kann der Varian Service oder der "Varian advanced exchange service" in Anspruch genommen werden.

ANMERKUNG

Vor dem Versand einer defekten Pumpe an die Fa. Varian muß das Formular "Sicherheit und Gesundheit", das diesem Handbuch beiliegt, ausgefüllt an Varian geschickt und bestätigt werden. Eine Kopie muß den Frachtpapieren beigelegt werden.

Eine eventuelle Verschrottung muß unter Einhaltung der einschlägigen landesüblichen Vorschriften erfolgen.

INDICATIONS GÉNÉRALES

Cet appareillage a été conçu en vue d'une utilisation professionnelle. Il est conseillé à l'utilisateur de lire attentivement cette notice d'instructions ainsi que toute autre indication supplémentaire fournie par Varian, avant d'utiliser l'appareil. Varian décline par conséquent toute responsabilité en cas d'observation totale ou partielle des instructions données, d'utilisation incorrecte de la part d'un personnel non formé, d'opérations non autorisées ou d'un emploi contraire aux réglementations nationales spécifiques.

Les pompes de la série Turbo-V1000 ICE sont des pompes turbomoléculaires conçues pour des applications de vide poussé et ultrapoussé, particulièrement adaptées à l'utilisation dans les secteurs liés à l'industrie des semi-conducteurs et elles sont appropriées pour le pompage de n'importe quel type de gaz ou de composé gazeux. Elles ne sont pas indiquées pour le pompage de liquides ou de particules solides.

L'effet de pompage est obtenu grâce à une turbine tournant à vitesse élevée (38000 tr/min maxi), actionnée par un moteur électrique triphasé à haut rendement. Les pompes Turbo-V1000 ICE sont totalement exemptes d'agents polluants et sont par conséquent indiquées pour des applications exigeant un vide "propre".

Les paragraphes suivants donnent toutes les indications nécessaires à garantir la sécurité de l'opérateur pendant l'utilisation de l'appareillage. Des renseignements plus détaillés se trouvent dans l'appendice "Technical Information".

Cette notice utilise les signes conventionnels suivants:



DANGER!

Les messages de danger attirent l'attention de l'opérateur sur une procédure ou une manœuvre spéciale qui, si elle n'est pas effectuée correctement, risque de provoquer de graves lésions.



ATTENTION !

Les messages d'attention apparaissent avant certaines procédures qui, si elles ne sont pas observées, pourraient endommager sérieusement l'appareillage.

NOTA

Les notes contiennent des renseignements importants, isolés du texte.

EMMAGASINAGE

Pendant le transport et l'emménagement des pompes, il faudra veiller à respecter les conditions environnementales suivantes:

- température: de - 20°C - à + 70°C
- humidité relative 0 - 95 % (non condensante)

Si le temps d'emménagement est très long, mettre la pompe en marche en mode SOFT START (voir la notice du contrôleur).

PRÉPARATION POUR L'INSTALLATION

La pompe est fournie dans un emballage de protection spécial; si l'on constate des marques de dommages pouvant s'être produits pendant le transport, contacter aussitôt le bureau de vente local. Pendant l'opération d'ouverture de l'emballage, veiller tout particulièrement à ne pas laisser tomber la pompe et à ne lui faire subir aucun choc ni aucune vibration.

Ne pas disperser l'emballage dans la nature. Le matériel est entièrement recyclable et il est conforme à la directive CEE 85/399 en matière de protection de l'environnement.



ATTENTION !

En vue d'éviter tous problèmes de dégazage, ne pas toucher, les mains nues, les éléments devant être exposés au vide. Mettre toujours des gants ou toute autre protection appropriée.

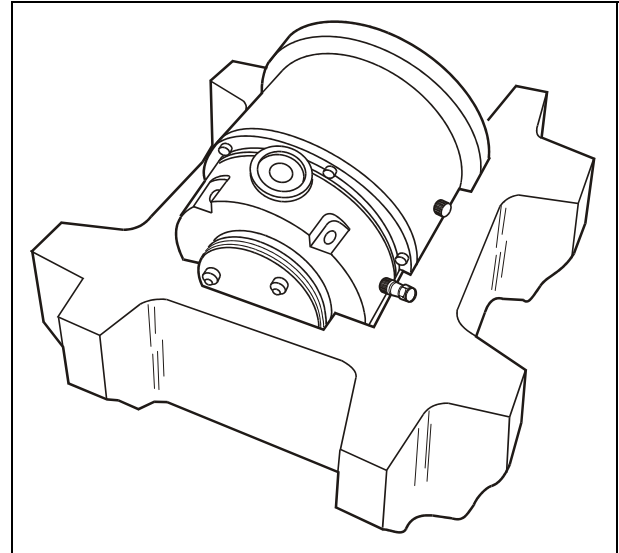

NOTE

La pompe ne peut être endommagée en restant simplement exposée à l'atmosphère. Il est de toute façon conseillé de la garder enfermée jusqu'au moment de l'installation, afin d'éviter toute pollution due à la poussière.

INSTALLATION



DANGER!

Compte tenu de son poids, la pompe doit toujours être maniée à l'aide d'appareils de levage et de manutention spéciaux.

Ne pas installer et/ou utiliser la pompe dans des milieux exposés à des agents atmosphériques (pluie, gel, neige), à des poussières, à des gaz de combat ainsi que dans des milieux explosifs ou à risque élevé d'incendie. Pendant le fonctionnement, il est nécessaire de respecter les conditions environnementales suivantes:

- pression maxi: 2 bar au-delà de la pression atmosphérique
- température: de +5°C à +35°C
- humidité relative: 0 - 95% (non condensante)



ATTENTION!

Ne retirer le ruban adhésif et le couvercle de protection qu'au moment du branchement de la turbopompe au système.

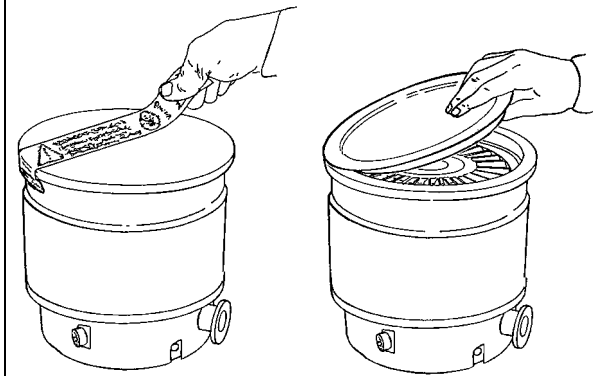



En présence de champs magnétiques, la pompe doit être protégée par des écrans appropriés. Pour tous autres détails, se reporter à l'appendice "Technical Information".

Les pompes turbomoléculaires de la série Turbo-V1000 ICE ne doivent être utilisées qu'avec l'un des contrôleurs spéciaux Varian (série 969-9447, 969-9547) et elles doivent être connectées à une pompe primaire (voir schéma dans "Technical Information").

La turbopompe peut être installée dans n'importe quelle position. Fixer la turbopompe dans une position stable, en reliant la bride d'entrée de la turbopompe à une contre-bride fixe pouvant supporter un couple de 4668 Nm autour de son axe.

La turbopompe à bride d'entrée ISO doit être fixée à la chambre à vide à l'aide de colliers doubles ou simples. Le tableau suivant décrit, pour chaque dimension de bride et pour chaque type de collier, le nombre de colliers nécessaires ainsi que le couple de serrage prescrit.

BRIDE	TYPE DE COLLIER	N.	COUPLE DE SERRAGE
ISO 200	Collier double à filetage M10	6	23 Nm
	Collier simple à filetage M10	6	23 Nm

Pour fixer la pompe au moyen de sa base, il est nécessaire d'utiliser trois vis M6 fixées aux trous prévus à cet effet se trouvant sur la base de la pompe. Les vis utilisées doivent avoir une limite d'élasticité de 550 N/mm² et être fixées à un couple de 4,5 Nm.

Pour l'installation des accessoires en option, voir "Technical Information".

UTILISATION

Toutes les instructions pour le fonctionnement correct de la turbopompe sont contenues dans la notice de l'unité de contrôle.

Il est conseillé de lire attentivement cette notice avant d'utiliser la pompe. Pour atteindre de meilleures pressions limite, il est possible de chauffer le carter de la pompe à l'aide du réchauffeur optionnel. Pendant le chauffage éventuel de la chambre à vide, la température de la bride d'entrée ne doit pas dépasser 120°C.

Utiliser toujours le refroidissement par eau pendant les opérations de chauffage.



Éviter de toucher la turbopompe ainsi que ses accessoires éventuels pendant les opérations de chauffage. La température élevée peut causer des lésions aux personnes.



Pour le refoulement de l'air de la pompe, utiliser de l'air ou du gaz inerte exempt de poussière ou de particules. La pression d'entrée à travers la porte prévue à cet effet doit être inférieure à 2 bar au-delà de la pression atmosphérique.



Lorsque la turbopompe fonctionne, éviter tout choc, oscillation ou déplacement brusque car les paliers pourraient se détériorer.



Pour le pompage de gaz de combat, ces pompes sont dotées d'une porte spéciale à travers laquelle il est nécessaire de fournir à la pompe un flux de gaz inerte (azote ou argon) pour protéger les coussinets (voir l'appendice "Technical Information").



Lorsque la pompe est utilisée pour le pompage de gaz toxiques, inflammables ou radioactifs, suivre les procédures typiques de chaque gaz.

Ne pas utiliser la pompe en présence de gaz explosifs.

ENTRETIEN

Les pompes de la série Turbo-V1000 ICE n'exigent aucun autre entretien. Toute opération doit être effectuée par un personnel agréé.



Avant de procéder à toute opération sur la turbopompe, débrancher le connecteur, refouler l'air de la pompe en ouvrant la soupape prévue à cet effet et attendre jusqu'à l'arrêt complet du rotor et jusqu'à ce que la température superficielle de la pompe soit inférieure à 50°C.

En cas de panne, il est possible de s'adresser au service réparations Varian ou bien au "Varian advanced exchange service" qui permet d'obtenir une pompe régénérée à la place de la pompe endommagée.

NOTE

Avant de renvoyer au constructeur une pompe pour des réparations ou un "advanced exchange service", remplir et faire parvenir au bureau local Varian la fiche "Sécurité et Santé" annexée à la présente notice d'instructions. Une copie de cette fiche devra être mise dans l'emballage de la pompe avant l'expédition.

En cas de mise au rebut de la pompe, procéder à son élimination conformément aux réglementations nationales en la matière.

INFORMACIÓN GENERAL

Este equipo se ha concebido para un uso profesional. El usuario deberá leer atentamente el presente manual de instrucciones y cualquier otra información suplementaria facilitada por Varian antes de utilizar el equipo. Varian se considera libre de cualquier responsabilidad debida al incumplimiento total o parcial de las instrucciones, al uso poco apropiado por parte de personal sin adiestrar, a las intervenciones no autorizadas o al uso que no cumpla con las normas nacionales específicas.

Las bombas de la serie Turbo-V1000 ICE son bombas turbomoleculares para aplicaciones de vacío alto y ultra alto especialmente adecuadas para el uso en los sectores relacionados con la industria de los semiconductores y pueden bombear cualquier tipo de gas o de compuesto gaseoso. No son apropiadas para bombear líquidos o partículas sólidas.

El efecto de bombeo se obtiene a través de una turbina que gira a gran velocidad (38000 r.p.m. máx.) movida por un motor eléctrico trifásico de grandes prestaciones. En las bombas Turbo-V1000 ICE no hay agentes contaminantes y, por lo tanto, son apropiadas incluso para las aplicaciones que necesitan un vacío "limpio".

En los párrafos siguientes se indica toda la información necesaria para garantizar la seguridad del operador durante el uso del equipo. Una información más detallada se facilita en el Suplemento "Technical Information".

Este manual utiliza los símbolos convencionales siguientes:



¡PELIGRO!

Los mensajes de peligro atraen la atención del operador sobre un procedimiento o una operación específica que, al no realizarse correctamente, podría provocar graves lesiones personales.



¡ATENCIÓN!

Los mensajes de atención se visualizan antes de procedimientos que, al no respetarse, podrían provocar daños al equipo.

NOTA

Las notas contienen información importante extraída del texto.

ALMACENAMIENTO

Durante el transporte y el almacenamiento de las bombas se deberá cumplir con las condiciones ambientales siguientes:

- temperatura: de -20°C a +70°C
- humedad relativa: 0 - 95% (no condensadora)

Si el periodo de almacenamiento es muy largo, poner en marcha la bomba en modalidad SOFT START (véase el manual de la unidad de control).

PREPARACIÓN PARA LA INSTALACIÓN

La bomba se suministra en un embalaje de protección dimensional; si se observan señales de daños, que podrían haberse producido durante el transporte, ponerse en contacto con la oficina de venta más cercana.

Durante la operación de desembalaje, prestar una atención especial a no dejar caer la bomba ni someterla a golpes.

No dispersar el embalaje en el medio ambiente. El material es totalmente reciclable y se ajusta a la directiva CEE 85/399 para la preservación del medio ambiente.



¡ATENCIÓN!

Para evitar la degasificación, no tocar con las manos sin guantes los componentes destinados a someterse al vacío. Utilizar siempre los guantes u otra protección apropiada.

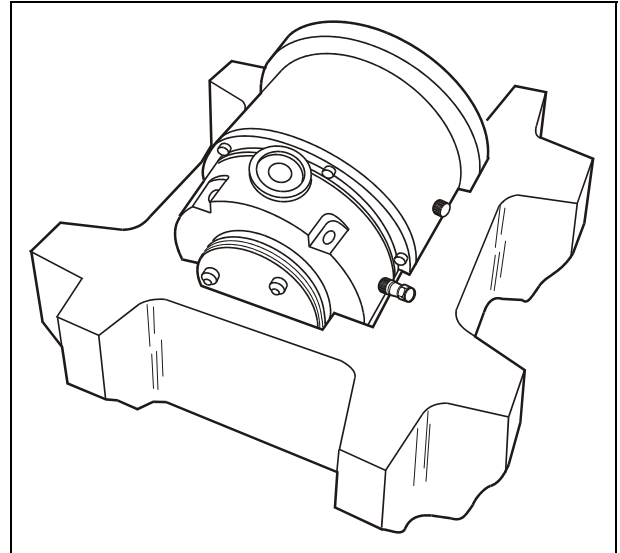

NOTA

La bomba no se puede dañar sólo por quedar expuesta a la atmósfera. De todas formas, se aconseja mantenerla cerrada hasta el momento de la instalación en el sistema para evitar una posible contaminación debida al polvo.

INSTALACIÓN



¡PELIGRO!

La bomba, a causa de su peso, ha de manejarse mediante herramientas de levantamiento y desplazamiento específicas.

No instalar ni utilizar la bomba en ambientes expuestos a agentes atmosféricos (lluvia, hielo, nieve), polvos, gases agresivos, en ambientes explosivos o con alto riesgo de incendio.

Durante el funcionamiento es preciso que se respeten las condiciones ambientales siguientes:

- presión máxima: 2 bar por encima de la presión atmosférica
- temperatura: de +5°C a +35°C
- humedad relativa: 0 - 95% (no condensadora).



¡ATENCIÓN!

Eliminar el adhesivo y quitar el tapón de protección sólo en el momento en que se conecte la turbobomba al sistema.

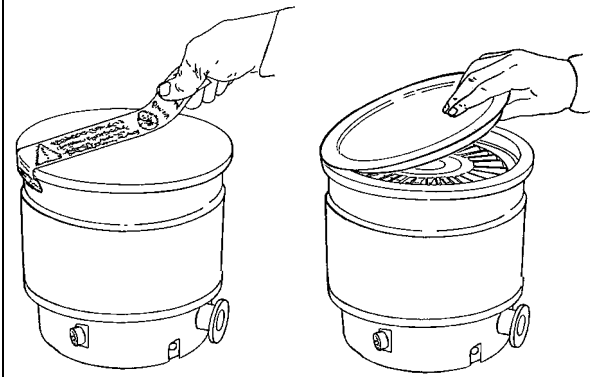



Cuando hay campos electromagnéticos la bomba ha de protegerse mediante pantallas oportunas. Véase el apéndice "Technical Information" para más detalles.

Las bombas turbomoleculares de la serie Turbo-V1000 ICE se deberán utilizar sólo con uno de los controladores apropiados Varian (serie 969-9447, 969-9547) y se deberán acoplar a una bomba primaria (véase esquema en "Technical Information").

La turbobomba se puede instalar en cualquier posición. Fijar la turbobomba en posición estable acoplando la brida de entrada de la turbobomba a una falsa brida fija que pueda soportar un par de 4668 Nm alrededor de su eje

La turbobomba con brida de entrada ISO ha de fijarse a la cámara de vacío mediante mordazas dobles o sencillas. La tabla siguiente describe, para cualquier dimensión de la brida y tipo de mordaza, el número de mordazas necesarias y a que par de apriete apretarlas.

BRIDA	TIPO DE MORDAZA	Nº	PAR DE APRIETE
ISO 200	Mordaza doble con roscado M10	6	23 Nm
	Mordaza sencilla con roscado M10	6	23 Nm

Para fijar la bomba mediante su base, es necesario utilizar tres tornillos M6 fijados en los orificios correspondientes que se encuentran en la base de la bomba. Los tornillos utilizados han de tener una carga de deformación elástica de 550 N/mm² y han de fijarse a un par de 4,5 Nm.

Para la instalación de los opcionales, véase "Technical Information".

UTILIZACIÓN

Todas las instrucciones para el funcionamiento correcto de la turbobomba se encuentran en el manual de la unidad de control.

Leer atentamente dicho manual antes de utilizarla.

Para obtener mejores presiones límite, se puede calentar la envoltura de la bomba utilizando el calentador opcional. Durante el posible calentamiento de la cámara de vacío, la temperatura de la brida de entrada no deberá superar 120°C.

Utilizar siempre la refrigeración por agua durante las operaciones de calentamiento.

¡PELIGRO!

No tocar la turbobomba y sus posibles accesorios durante las operaciones de calentamiento. La alta temperatura puede provocar lesiones a las personas.

¡ATENCIÓN!

Para el envío de aire de la bomba utilizar aire o gas inerte sin polvo o partículas. La presión de entrada a través de la puerta apropiada deberá ser inferior a 2 bar por encima de la presión atmosférica.

¡ATENCIÓN!

Evitense golpes, oscilaciones o bruscos desplazamientos de la turbobomba durante su funcionamiento. Los cojinetes podrían dañarse.

¡ATENCIÓN!

Para bombear gases agresivos estas bombas están dotadas de una puerta específica mediante la cual es necesario suministrar a la bomba un caudal de gas inerte (Nitrógeno o Argón) para proteger los rodamientos (véase el apéndice "Technical Information").

¡PELIGRO!

Cuando la bomba se utiliza para bombear gases tóxicos, inflamables o radioactivos, seguir los procedimientos apropiados típicos de cada gas.

No usar la bomba cuando haya gases explosivos.

MANTENIMIENTO

Las bombas de la serie Turbo-V1000 ICE no necesitan ningún mantenimiento. Cualquier intervención deberá ser realizada por personal autorizado.

¡PELIGRO!

Antes de realizar cualquier intervención en la turbobomba, desempalmar el conector de alimentación, enviar aire a la bomba abriendo la válvula apropiada y esperar hasta que el rotor se pare completamente y esperar a que la bomba esté por debajo de 50 °C.

En caso de avería se podrá utilizar el servicio de reparación Varian o el "Varian advanced exchange service", que permite obtener una bomba regenerada para sustituir la averiada.

NOTA

Antes de enviar al fabricante una bomba para su reparación o "advanced exchange service", es imprescindible cumplimentar y remitir a la oficina de Ventas más cercana la ficha de "Seguridad y Salud" adjunta al presente manual de instrucciones. Una copia de la misma se deberá introducir en el embalaje de la bomba antes de enviarla.

En caso de que la bomba se tenga que desgazar, efectuar su eliminación respetando las normas nacionales específicas.

INFORMAÇÕES GERAIS

Esta aparelhagem destina-se ao uso profissional. O utilizador deve ler atentamente o presente manual de instruções e qualquer outra informação adicional fornecida pela Varian antes de usar a aparelhagem. A Varian não se responsabiliza pela eventual inobservância total ou parcial das instruções, pelo uso indevido por parte de pessoas não treinadas, por operações não autorizadas ou pelo uso contrário às normas nacionais específicas.

As bombas da série Turbo-V1000 ICE são bombas turbomoleculares para aplicações de alto e ultra-alto vácuo, especialmente apropriadas para o uso nos sectores ligados à indústria dos semicondutores, e são capazes de bombear qualquer tipo de gás ou de composto gasoso. Não são adequadas para bombear líquidos ou partículas sólidas.

O efeito da bomba é obtido através de uma turbina rotativa de alta velocidade (38000 r.p.m. máx.) movida por um motor eléctrico de três fases de alto rendimento. As bombas Turbo-V1000 ICE são totalmente sem agentes contaminadores e, portanto, são adequadas para aplicações que requerem um vácuo "limpo".

Nos parágrafos seguintes estão descritas todas as informações necessárias para garantir a segurança do técnico durante o uso da aparelhagem. Informações detalhadas são fornecidas no apêndice "Technical Information".

Este manual utiliza as seguintes convenções:



PERIGO!

As mensagens de perigo chamam a atenção do técnico para um procedimento ou uma prática específica que, se não efectuada correctamente, poderia provocar graves lesões pessoais.



ATENÇÃO!

As mensagens de atenção são visualizadas antes de procedimentos que, se não observados, poderiam causar danos à aparelhagem.

NOTA

As notas contêm informações importantes destacadas do texto.

ARMAZENAGEM

Durante o transporte e a armazenagem das bombas não devem ser superadas as seguintes condições ambientais:

- temperatura: de -20°C a +70°C
- humidade relativa: 0 - 95% (não condensante)

Se o tempo de armazenagem for muito longo, accionar a bomba em SOFT START (ver manual da unidade de controlo).

PREPARAÇÃO PARA A INSTALAÇÃO

A bomba é fornecida numa embalagem protectora especial; se apresentarem sinais de danos, que poderiam verificar-se durante o transporte, entrar em contacto com o escritório de vendas local.

Durante a retirada da embalagem, tomar muito cuidado para não deixar cair a bomba e não submetê-la a colisões ou vibrações.

Não depositar a embalagem no meio ambiente. O material é completamente reciclável e responde às normas CEE 85/399 para a protecção do meio ambiente.



ATENÇÃO!

Para evitar problemas de perdas de gás, não tocar com as mãos os componentes destinados à exposição do vácuo. Utilizar sempre luvas ou outra protecção adequada.

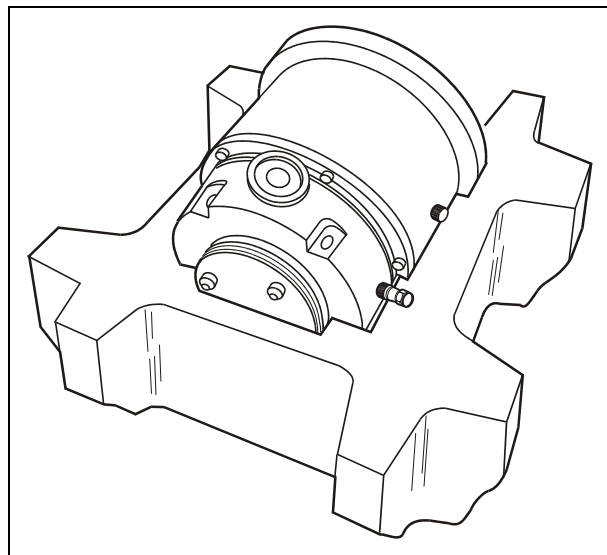

NOTA

A bomba não pode ser danificada permanecendo simplesmente exposta à atmosfera. Aconselha-se, no entanto, mantê-la fechada até o momento da instalação no sistema para evitar que se suje com poeiras.

INSTALAÇÃO



PERIGO!

A bomba, devido ao seu peso, deve ser manejada utilizando ferramentas específicas de levantamento e deslocamento.

Não instalar e/ou usar a bomba em ambientes expostos a agentes atmosféricos (chuva, gelo, neve), poeiras, gases agressivos, em ambientes com possibilidade de explosão ou com elevado risco de incêndio..

Durante o funcionamento é necessário que sejam respeitadas as seguintes condições ambientais:

- pressão máxima: 2 bar além da pressão atmosférica
- temperatura: de + 5°C a + 35°C
- humidade relativa: 0 - 95% (não condensante).



ATENÇÃO!

Remover o adesivo e retirar o tampão de protecção só no momento da ligação da turbobomba ao sistema.

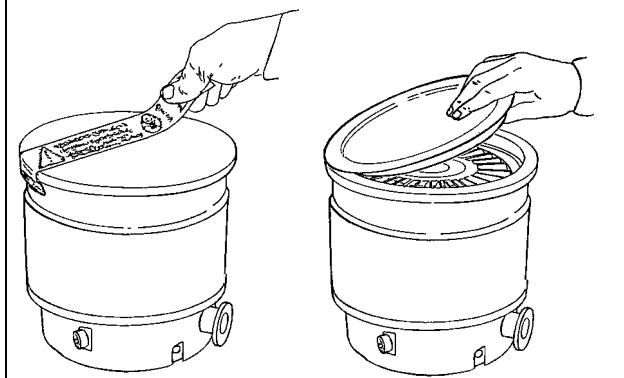



Existindo campos magnéticos, a bomba deve ser protegida com blindagens adequadas. Ver o apêndice "Technical Information" para maiores detalhes.

As bombas turbomoleculares da série Turbo-V1000 ICE devem ser utilizadas somente com um dos controladores Varian específicos (série 969-9447, 969-9547) e devem ser ligadas a uma bomba primária (ver esquema em "Technical Information").

A turbobomba pode ser instalada em qualquer posição. Fixar a turbobomba em posição estável ligando a flange de entrada da turbobomba a uma contraflange fixa capaz de resistir a um torque de 4668 Nm ao redor do próprio eixo.

A turbobomba com flange de entrada ISO, deve ser fixada à câmara de vácuo através de bornes duplos ou simples. A tabela a seguir descreve, para cada dimensão de flange e tipo de borne, o número de bornes e o torque de aperto necessários.

FLANGE	TIPO DE BORNE	Nº	TORQUE DE APERTO
ISO 200	Borne duplo com rosca M10	6	23 Nm
	Borne simples com rosca M10	6	23 Nm

Para fixar a bomba através da sua base, é necessário utilizar três parafusos M6 fixados aos furos específicos existentes na base da bomba. Os parafusos utilizados devem possuir um limite de carga de 550 N/mm² e devem ser fixados com um torque de 4,5 Nm.

Para a instalação dos acessórios opcionais, ver "Technical Information".

UTILIZAÇÃO

Todas as instruções para o correcto funcionamento da turbobomba estão contidas no manual da unidade de controlo. Ler atentamente este manual antes da utilização.

Para atingir melhores pressões limite é possível aquecer o invólucro da bomba utilizando o aquecedor opcional. Durante o eventual aquecimento da câmara a vácuo, a temperatura no flange de entrada não deve ser superior a 120 °C.

Utilizar sempre o resfriamento com água durante as operações de aquecimento.



PERIGO!

Não tocar a turbobomba e os seus eventuais acessórios durante as operações de aquecimento. A elevada temperatura pode causar lesões às pessoas.



ATENÇÃO!

Para a saída de ar da bomba utilizar ar ou gás inerte sem poeiras ou partículas. A pressão de entrada através da porta específica deve ser inferior a 2 bar (além da pressão atmosférica).



ATENÇÃO!

Evitar colisões, oscilações ou deslocamentos bruscos da turbobomba quando está a funcionar. Os rolamentos poderiam sofrer danos.



ATENÇÃO!

Para bombear gases agressivos, estas bombas estão equipadas com uma porta específica através da qual é necessário fornecer à bomba um fluxo de gás inerte (Azoto ou Argon) para proteger os rolamentos (ver o apêndice "Technical Information").



PERIGO!

Quando a bomba é utilizada para bombear gases tóxicos, inflamáveis ou radioactivos, seguir os procedimentos adequados típicos para cada gás.

Não usar a bomba na presença de gases explosivos.

MANUTENÇÃO

As bombas da série Turbo-V1000 ICE não requerem qualquer manutenção. Qualquer operação deve ser efectuada por pessoal autorizado.



PERIGO!

Antes de efectuar qualquer operação na turbobomba desligar o conector de alimentação, introduzir ar na bomba abrindo a válvula específica, aguardar até a completa paragem do rotor e até que a temperatura superficial da bomba seja inferior a 50 °C.

Em caso de defeito é possível usufruir do serviço de reparação Varian ou do "Varian advanced exchange service", que permite obter uma bomba regenerada que substitua a bomba com defeito.

NOTA

Antes de enviar ao construtor uma bomba para reparações ou advanced exchange service, é indispensável preencher e enviar ao escritório local de vendas a ficha "Segurança e Saúde" anexa ao presente manual de instruções. A cópia da mesma deve ser colocada na embalagem da bomba antes da expedição.

Caso uma bomba deva ser destruída, proceder à sua eliminação respeitando as normas nacionais específicas.

ALGEMENE INFORMATIE

Deze apparatuur is bestemd voor beroepsmatig gebruik. De gebruiker wordt verzocht aandachtig deze handleiding en alle overige door Varian verstrekte informatie door te lezen alvorens het apparaat in gebruik te nemen. Varian acht zich niet aansprakelijk voor de gevolgen van het niet of gedeeltelijk in acht nemen van de aanwijzingen, onoordeelkundig gebruik door niet hiervoor opgeleid personeel, reparaties waarvoor geen toestemming is verkregen of gebruik in strijd met de specifieke nationale wetgeving.

De pompen van de serie Turbo-V1000 ICE zijn turbomoleculaire pompen voor hoge en ultrahoge vacuümtoepassingen, uitermate geschikt voor toepassing in sectoren die te maken hebben met de halfgeleiderindustrie, die in staat zijn om elk type gas of gasverbinding te pompen. Ze zijn niet geschikt voor het pompen van vloeistoffen of vaste deeltjes.

Het pompeffect wordt verkregen door een zeer snel draaiende turbine (max. 38000 toeren/min.) die aangedreven wordt door een elektrische draaistroommotor met hoog rendement. De Turbo-V1000 ICE pompen zijn volledig vrij van verontreinigingen en zijn dus ook geschikt voor toepassingen die een "schoon" vacuüm verlangen.

In de volgende paragrafen is alle informatie vermeld om de veiligheid van de operator tijdens het gebruik van de apparatuur te verzekeren. Gedetailleerde informatie is te vinden in de bijlage "Technical information".

Deze handleiding gebruikt de volgende symbolen:



GEVAAR!

Bij dit symbool staat tekst die de aandacht van de operator vestigt op een speciale procedure of methode die, indien niet correct uitgevoerd, ernstig lichamelijk letsel kan veroorzaken.



ATTENTIE!

Bij dit symbool staat tekst met procedures die, indien niet opgevolgd, schade aan apparatuur kunnen veroorzaken.

OPMERKING

De opmerkingen bevatten belangrijke informatie die uit de tekst is gelicht.

OPSLAG

Tijdens het transport en de opslag van de pompen moeten de volgende omgevingscondities aanwezig zijn:

- temperatuur: van -20°C tot +70°C
- relatieve vochtigheid: 0 - 95% (niet condenserend)

Als de opslagperiode van lange duur is, de pomp met de SOFT START wijze opstarten (zie handleiding regeleenheid).

UITPAKKEN

De pomp wordt in een speciale beschermende verpakking geleverd; als er schade wordt geconstateerd die tijdens het transport veroorzaakt zou kunnen zijn, meteen contact opnemen met het plaatselijke verkoopkantoor.

Zorg er bij het uitpakken voor dat de pomp niet kan vallen of stoten te verduren krijgt.

Laat de verpakking niet ergens buiten achter. Het verpakkingsmateriaal is volledig recyclebaar en voldoet aan de EEG milieuriichtlijn 85/399.



ATTENTIE!

Om ontgassingsproblemen te voorkomen, mogen de componenten die met het vacuüm in aanraking komen niet met de blote handen aangeraakt worden. Gebruik altijd handschoenen of een andere geschikte bescherming.

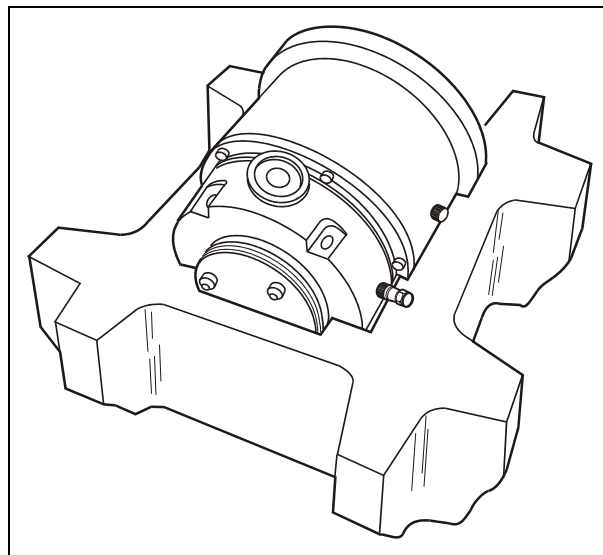

OPMERKING

De pomp kan niet beschadigd worden door eenvoudigweg aan de atmosfeer blootgesteld te worden. Toch wordt aangeraden om de pomp gesloten te houden zolang deze niet in het systeem wordt ingebouwd, zodat eventuele vervuiling door stof wordt voorkomen.

INSTALLATIE



GEVAAR!

De pomp moet, in verband met haar gewicht, met speciale hefen- en transportwerktuigen worden verplaatst.

De pomp mag niet geïnstalleerd en/of gebruikt worden in ruimten die blootgesteld zijn aan de weersomstandigheden (regen, vorst, sneeuw), stof, agressieve gassen, of in ruimten met explosiegevaar of zeer hoog brandgevaar.

Tijdens de werking moeten de volgende omgevingscondities aanwezig zijn:

- max. druk: 2 bar boven de atmosferische druk
- temperatuur: van +5°C tot +35°C
- relatieve vochtigheid: 0 - 95% (niet condenserend).



ATTENTIE!

Alleen op het moment waarop de turbopomp op het systeem wordt aangesloten mogen de sticker en de beschermdop verwijderd worden.

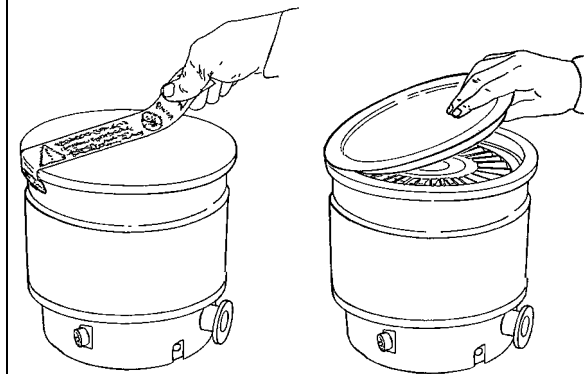

NEE!



GEVAAR!

Om persoonlijk letsel te voorkomen mogen nooit, om geen enkele reden, de vingers of voorwerpen in de inlaatopening van de turbopomp worden gestoken. Men raadt gebruik van het beschermgaasje aan (optional). Als een trillingdemper of een metalen flexibel balgje op de inlaatopening wordt aangebracht, de turbopomp altijd aan de basis bevestigen.

Bij aanwezigheid van magnetische velden moet de pomp op passende wijze afgeschermd worden. Zie de bijlage "Technical Information" voor meer informatie.

De turbomoleculaire pompen van de serie V1000 ICE mogen alleen gebruikt worden in combinatie met een van de speciale Varian controllers (serie 969-9447, 969-9547) en moeten aangesloten zijn op een primaire pomp (zie schema in "Technical information").

De turbopomp kan in alle standen worden geïnstalleerd. Bevestig de turbopomp in een stabiele positie en verbind de inlaatflens van de turbopomp met een vaste contraflens die een koppel van 4668 Nm rondom de eigen as kan verdragen.

De turbopomp met ISO inlaatflens moet aan de vacuümkamer worden verbonden met behulp van dubbele of enkelvoudige klemmen. De volgende tabel beschrijft, voor elke maat flens of klemtype, het aantal benodigde klemmen en het aanhaalkoppel waarmee ze vastgezet moeten worden.

FLENS	KLEMTYPE	NR.	AANHAAL-KOPPEL
ISO 200	Dubbele klem met M10 schroefdraad	6	23 Nm
	Enkelvoudige klem met M10 schroefdraad	6	23 Nm

Om de pomp met behulp van zijn basis te bevestigen, zijn drie M6 bouten nodig die in de gaten in de basis van de pomp worden ingebracht. Deze bouten moeten een vloeisterkte van 550 N/mm² bezitten en met een koppel van 4,5 Nm worden aangehaald.

Zie "Technical Information" voor installatie van accessoires die als optie verkrijgbaar zijn.

GEBRUIK

Alle aanwijzingen voor de correcte werking van de turbopomp zijn in de handleiding van de regeleenheid vermeld.

Lees aandachtig deze handleiding vóór ingebruikname door. Om een betere grensdruk te bereiken, kan het pomphuis verwarmd worden met behulp van een optionele verwarmingsunit. Tijdens de eventuele verwarming van de vacuümkamer mag de temperatuur op de inlaatflens niet meer dan 120° C bedragen.

Pas tijdens het verwarmen altijd waterkoeling toe.



GEVAAR!

Raak de pomp en eventuele accessoires niet tijdens het verwarmen aan. De hoge temperatuur kan lichamelijk letsel veroorzaken.



ATTENTIE!

Gebruik voor de luchttoevoer naar de pomp lucht of inert gas zonder stof of vaste deeltjes. De inlaatdruk via de hiervoor bestemde poort moet minder dan 2 bar (boven de atmosferische druk) bedragen.



ATTENTIE!

Vermijd schokken, trillingen of bruuske verplaatsingen van de turbopomp wanneer deze in werking is. De lagers kunnen anders beschadigd raken.



ATTENTIE!

Deze pompen zijn voor het pompen van agressieve gassen van een speciale poort voorzien, waardoor de pomp een stroom inert gas (stikstof of argon) ter bescherming van de lagers krijgt geleverd (zie bijlage "Technical Information").



GEVAAR!

Wanneer de pomp wordt gebruikt voor het pompen van brandbare, giftige of radioactieve gassen, moeten de procedures worden gevolgd die speciaal voor elk type gas zijn opgesteld.

Gebruik de pomp niet in aanwezigheid van explosieve gassen.

ONDERHOUD

De pompen van de serie Turbo-V1000 ICE zijn onderhoudsvrij. Eventuele werkzaamheden moeten door bevoegd personeel worden uitgevoerd.



GEVAAR!

Alvorens werkzaamheden aan de turbopomp uit te voeren, de stekker verwijderen, de pomp met behulp van de hiervoor bestemde klep ontluichten en wachten totdat de rotor volledig stil staat en de oppervlaktetemperatuur van de pomp onder een temperatuur van 50 °C is gezakt.

In geval van storing is het mogelijk om de reparatiedienst van Varian of de "Varian advanced exchange service" in te schakelen: zo krijgt men een ruilpomp ter vervanging van de defecte pomp.

OPMERKING

Alvorens de pomp ter reparatie of ruil naar de fabrikant op te sturen, moet de bij deze handleiding gevoegde kaart "Veiligheid en Gezondheid" volledig ingevuld naar het plaatselijke verkoopkantoor worden gestuurd. Een kopie van deze kaart moet vóór versturing bij de pomp in de verpakking worden gevoegd.

Mocht de pomp gesloopt worden, ga dan overeenkomstig de specifieke nationale wetgeving te werk.

GENEREL INFORMATION

Dette materiel er beregnet til professionel anvendelse. Brugeren bedes læse denne håndbog samt enhver yderligere vejledning, Varian har leveret, inden udstyret tages i brug. Varian er ikke ansvarlig, hvis vejledningen ikke er nøje fulgt, eller hvis den kun er delvist fulgt, og heller ikke hvis udstyret anvendes forkert af ukvalificeret personale, hvis der foretages uautoriserede indgreb på det, eller hvis udstyret benyttes på en måde, der står i kontrast til det pågældende lands særlige normer.

Turbo-V1000 ICE serien omfatter turbomolekulære pumper til højvakuum og til ultra-højvakuum, der er specielt velegnede til brug i industrier, hvor halvledere anvendes. Pumperne er i stand til at pumpe alle typer luftarter og luftforeninger. Denne serie er ikke egnet til at pumpe væsker eller faste partikler.

Pumpeeffekten opnås ved hjælp af en turbine, der roterer ved høj hastighed (max. 38000 omdr./min.) drevet af en højeffektiv trefaset elektrisk motor. Turbo-V1000 ICE pumperne er fuldstændig fri for forurenende stoffer og finder derfor god anvendelse, når der kræves et "rent" vakuum.

I det følgende gives alle nødvendige oplysninger for operatørens sikkerhed under brug af udstyret. For detaljerede oplysninger henvises til den vedlagte "Technical Information".

I denne håndbog findes følgende regler:



ADVARSEL!

Advarselne henkalder operatørens opmærksomhed på et indgreb eller en særlig handling, der kan forårsage alvorlig fare for kvæstelser, hvis den ikke udføres korrekt.



VIGTIGT !

Disse ord forekommer inden en arbejdsmetode, der skal overholdes for ikke at skabe risiko for skade på udstyret.

BEMÆRK

Bemærkningerne indeholder vigtige yderligere oplysninger.

OPLAGRING

Under transport og oplagring af pumperne skal følgende omgivelsesbetingelser være overholdt:

- temperatur: fra -20°C til +70°C
- relativ fugtighed: 0 - 95% (ikke kondenserende)

Hvis pumperne oplagres gennem lang tid, skal de sættes i gang på den såkaldte 'SOFT START' måde (se håndbogen til kontrolenheden).

FORBEREDELSE TIL MONTERING

Pumpen leveres med en særlig beskyttelsesemballage. Kontakt vores lokale salgskontor, hvis der findes tegn på beskadigelse, der kan være sket under transporten.

Pas på at pumpen ikke falder på gulvet og at der ikke stødes til den under udpakningen.

Smid ikke emballagen væk ude i naturen. Al emballage er genbrugsmateriale i overensstemmelse med direktivet 85/399/EØF vedrørende miljøbeskyttelse.



VIGTIGT !

For at undgå afgangsproblemer skal man ikke røre med de bare hænder de dele, der vil blive udsat for vakuum. Brug altid handsker eller anden passende beskyttelse.

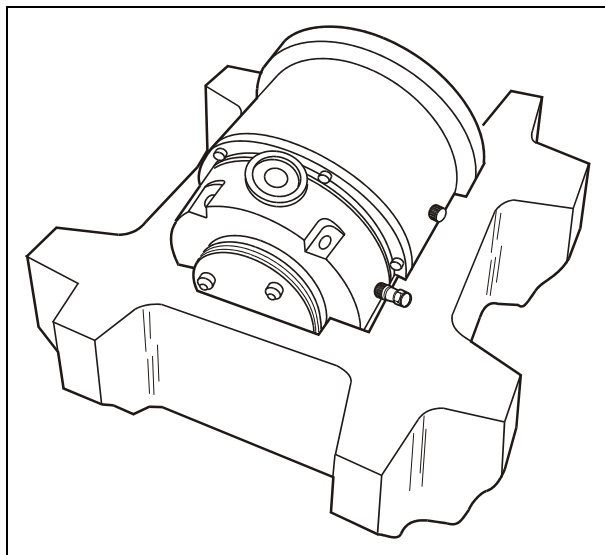

BEMÆRK

Pumpen kan ikke beskadiges ved blot at være udsat for den atmosfæriske luft. For at undgå forurening fra støv anbefales det dog, at pumpen holdes tilpakket, indtil den monteres i anlægget.

MONTERING



ADVARSEL!

Grundet dens vægt må pumpen kun håndteres ved hjælp af dertil bestemt løfte- og flytningsudstyr.

Pumpen må ikke installeres eller bruges i omgivelser, der udsætter den for forvitring (regn, frost, sne), støv, ætsende luftarter, og heller ikke i omgivelser med eksplosionsfare eller stor brandfare.

Følgende betingelser skal overholdes under driften:

- maksimaltryk: 2 bar (over atmosfærisk tryk)
- temperatur: fra +5°C til +35°C
- relativ fugtighed: 0 - 95% (ikke kondenserende).



VIGTIGT !

Tapen og beskyttelsesproppen må først fjernes, når turbopumpen sluttes til systemet.

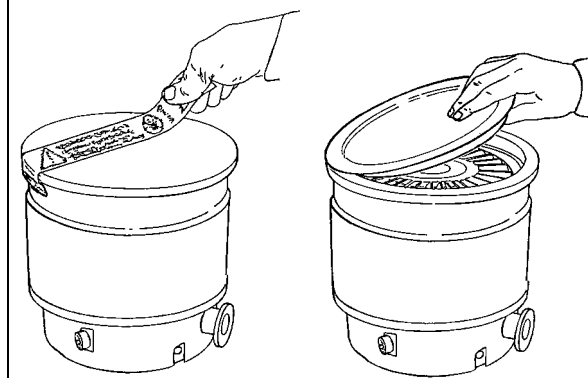



Hvis der findes magnetfelter må pumpen afskærmes. Se bilag "Technical Information" for yderligere detaljer. Turbomolekylærpumperne i Turbo-V1000 ICE serien må kun anvendes med en af de særlige Varian kontrolapparater (serie 969-9447, 969-9547) og skal forbindes med en primær pumpe (se skemaet i "Technical Information"). Turbopumpen kan monteres i hvilken som helst stilling. Den fastspændes ved, at turbopumpens indgangsflange fastgøres til en fast modflange, der er i stand til at modstå et drejningsmoment på 4668 Nm omkring akse. Turbopumperne med ISO indløbsflange skal fastspændes til vakuumkammeret med dobbelte eller enkelte klemmer. Følgende tabel angiver det nødvendige antal af klemmer og det anvendte tilspændingsmoment for de enkelte flangedimensioner og typer af klemmer.

FLANGE	KLEMMETYPE	ANT.	DREJNINGSMOMENT
ISO 200	Dobbelt klemme, gevind M10	6	23 Nm
	Enkelt klemme, gevind M10	6	23 Nm

For at fastspænde pumpen til fundamentet er det nødvendigt at anvende tre M6-skruer, som indsættes i hullerne på pumpens fundament. Skruerne skal klare en belastning på 550 N/mm². Skruernes korrekte tilspændingsmoment er 4,5 Nm. Se "Technical Information" for montering af optionals.

ANVENDELSE

Al vejledning angående turbopumpens korrekte drift er beskrevet i håndbogen til kontrolenheden. Læs den nævnte håndbog omhyggeligt før brugen. For at opnå bedre grænsetryk kan pumpebeklædningen opvarmes. Hvis vakuumkammeret opvarmes, må temperaturen på indgangsflangen ikke overstige 120°C. Brug altid vandafkøling under opvarmningen.



ADVARSEL!

Rør ikke ved turbopumpen eller eventuelt tilbehør under opvarmningsmanøvrerne. Den høje temperatur kan forårsage kvæstelser på personer.



VIGTIGT!

Til pumpens luftafløb anvendes luft eller en inaktiv luftart, der er fri for støv og partikler. Indgangstrykket gennem den særlige åbning skal være under 2 bar.



VIGTIGT!

Undgå sammenstød, vibrationer eller bratte bevægelser i forbindelse med brug af turbopumpen. Der er risiko for beskadigelse af lejerne.



VIGTIGT!

Til pumpning af ætsende luftarter er disse pumper forsynet med en særlig åbning, hvortil den passive luftart (argon eller kvælstof) skal sluttes for at beskytte lejerne (se bilaget "Technical Information").



ADVARSEL!

Når pumpen anvendes til pumpning af giftige, brandfarlige eller radioaktive gasser, skal de gældende forskrifter for den enkelte gastype strengt overholdes. Pumpen må ikke anvendes i eksplosionsfarlige miljøer.

VEDLIGEHOLDELSE

Pumperne af Turbo-V1000 ICE typen behøver ikke nogen vedligeholdelse. Ethvert indgreb på pumpen skal foretages af autoriseret personale.



ADVARSEL!

Inden der foretages noget som helst indgreb på turbopumpen, skal strømmen først afbrydes og luften lukkes ud af pumpen ved, at man åbner den særlige ventil og venter indtil rotoren er standset helt, og pumpens overfladetemperatur er lavere end 50°C.

Hvis pumpen går i stykker, kan man benytte sig af Varians reparatørsservice eller af Varians "Advanced Exchange Service", hvorved man kan få en repareret pumpe i bytte for den, der er gået i stykker.

BEMÆRK

Inden pumpen sendes tilbage til fabrikanten til reparation eller til "Advanced Exchange Service", skal man udfylde formularen "Sikkerhed og Helbred" vedlagt denne håndbog og tilsende den til den lokale forhandler. En kopi af formularen skal vedlægges i pakken med pumpen ved tilbagesendelsen.

Hvis en pumpe skal skrottes, skal dette foregå i overensstemmelse med det pågældende lands særlige love.

ALLMÄN INFORMATION

Utrustningen är avsedd för yrkesmässig användning. Användaren bör läsa denna bruksanvisning, samt övrig dokumentation från Varian före användning av utrustningen. Varian tar inget ansvar för skador helt eller delvis till följd av åsidosättande av instruktionerna, olämplig användning av person utan tillräcklig kunskap, obehörigt bruk av utrustningen eller hantering som strider mot gällande lokala föreskrifter.

Pumparna i Turbo-V1000 ICE-serien är turbomolekylära pumpar för höga och mycket höga vakuumbillämpningar inom halvledarindustrin. De kan användas för pumpning av alla typer av gas eller gasföreningar. De lämpar sig inte för pumpning av vätskor eller fasta partiklar.

Pumpningen åstadkoms med hjälp av en högvarv turbin (max 38000 varv/minut) som drivs av en trefas högeffektmotor. Inga tillsatssämnen används i Turbo-V1000 ICE-seriens pumpar, som därför passar för tillämpningar som kräver ett "rent" vakuum.

De följande avsnitten innehåller all information som behövs för att garantera operatörens säkerhet under användningen. Detaljerade uppgifter finns i bilagan "Technical information".

I bruksanvisningen används följande standardrubriker:



VARNING!

Varningsmeddelandena informerar operatören om att en speciell procedur eller en viss typ av arbete måste utföras exakt enligt anvisningarna. I annat fall finns risk för svåra personskador.



VIKTIGT !

Detta varningsmeddelande visas framför procedurer som måste följas exakt för att inte risk för maskinskada skall uppstå.

OBSERVERA

Detta visar på viktig information i texten.

FÖRVARING

Följande krav på omgivningsförhållanden gäller vid transport och förvaring av pumpen:

- temperatur: från -20°C till +70°C
- relativ luftfuktighet: 0 - 95% (utan kondens)

Efter lång förvaring skall pumpen startas med MJUKSTART - metoden (se bruksanvisningen för styrenheten).

FÖRBEREDELSE FÖR INSTALLATIONEN

Pumpen levereras i ett särskilt skyddande emballage. Kontakta det lokala försäljningskontoret om emballaget visar tecken på skador som kan ha uppstått under transporten.

Se till att pumpen inte tappas eller utsätts för stötar vid upppackningen.

Kasta inte packmaterialet i soporna. Materialet är återvinningsbart till 100% och uppfyller EU-direktiv 85/399 om miljöskydd.



VIKTIGT !

Komponenter som skall utsättas för vakuum får inte hanteras med bara händer p g a kontamineringsrisken. Använd alltid handskar eller liknande skydd.

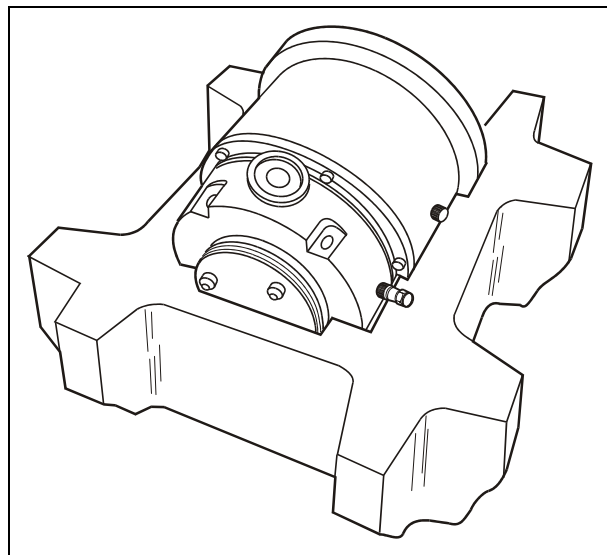

OBSERVERA

Normal påverkan från omgivningen kan inte skada pumpen. Trots det är det säkrast att hålla den stängd tills den har installerats i systemet, för att förhindra att det kommer in damm eller annat i den.

INSTALLATION



VARNING!

Med tanke på pumpens vikt får den endast hanteras med hjälp av därtill avsedda lyft- och flyttingsanordningar.

Installera inte pumpen i miljöer som utsätts för påverkan från atmosfären (regn, snö, is), damm, aggressiva gaser, och inte heller i explosiv eller brandfarlig miljö.

Följande krav på omgivningsförhållanden gäller vid drift:

- maximitryck: 2 bar (över atmosfäriskt tryck)
- temperatur: från +5°C till +35°C
- relativ luftfuktighet: 0 - 95% (utan kondens).



VIKTIGT !

Ta bort tejpens och skyddsproppens först när turbopumpen ska anslutas till systemet.

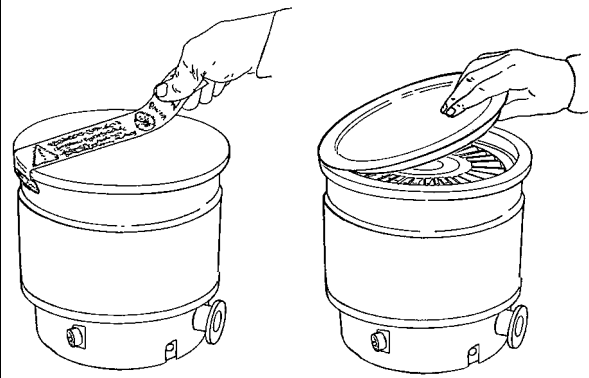



I närvaro av magnetfält skall pumpen skyddas med en särskild skärm. Se bilagan "Technical information" för ytterligare upplysningar.

Turbomolekylärpumparna i serien V1000 ICE måste användas med en särskild styrenhet från Varian (serie 969-9447, 969-9547), och anslutas till en förpump (se schemat " Technical information ").

Turbopumpen kan installeras i valfri position. Fäst turbopumpen i ett stabilt läge genom att ansluta pumpens intagsfläns till en fast fläns som måste tåla ett vridmoment på 4668 Nm runt den genomgående axeln.

Turbopumpen med ISO-intagsfläns ska fästas i vakuunkammaren med hjälp av dubbla eller enkla klamrar. Den följande tabellen beskriver olika flänsstorlekar, olika typer av klamrar, nödvändigt antal klamrar och åtdragningsmoment.

FLÄNS	TYP AV KLAMMER	ANT.	ÅTDRAGNINGSMOMENT
ISO 200	Dubbel klammer, gänga M10	6	23 Nm
	Enkel klammer, gänga M10	6	23 Nm

För att fästa pumpen till fundamentet är det nödvändigt att använda 3 M6 skruvar, som installeras i hålen på pumpens fundament. De använda skruvarna måste tåla en belastning på 550 N/mm² korrekt åtdragningsmoment är 4,5 Nm. Installation av tillbehörsutrustning beskrivs i "Technical Information".

ANVÄNDNING

Anvisningar för riktig användning av turbopumpen finns i styrenhetens bruksanvisning.

Läs bruksanvisningen noga innan du startar pumpen.

För att förbättra tryckgränserna kan pumphuset värmas med ett särskilt värmeaggregat som finns som tillval. Under uppvärmningen av pumploppet får temperaturen vid inloppet aldrig bli högre än 120 °C.

Under uppvärmningen måste vattenkyllningen användas.



VARNING!

Vidrör inte turbopumpen eller några tillbehör under uppvärmningen för att undvika brännskador.



VIKTIGT!

Använd luft eller ädelgas, fri från damm och partiklar för luftning av pumpen. Trycket vid inloppet får vara högst 2 bar (över atmosfäriskt tryck).



VIKTIGT!

Undvik sammanstötningar, svängningar eller plötsliga förflyttningar av turbopumpen när den är igång. Lagren kan bli skadade.



VIKTIGT!

För pumpning av frätande gaser är dessa pumpar försedda med en speciell öppning igenom vilken man skall leda en ström av ädelgas (kväve eller argon) för att skydda lagren (se bilagan "Technical information").



VARNING!

Då pumpen används för pumpning av giftiga, lättantändliga eller radioaktiva typ, bör man följa de särskilda anvisningarna för varje enskild gas.

Använd ej pumpen i närheten av explosiva gaser.

UNDERHÅLL

Pumparna i Turbo-V1000 ICE-serien är underhållsfria. Allt servicearbete måste utföras av auktoriserad personal.



VARNING!

Innan något arbete utförs på turbopumpen måste pumpens strömförsörjning brytas och pumpen luftas genom att den aktuella ventilen öppnas. Vänta sedan tills rotorn stannat samt tills pumpens yttemperatur är lägre än 50°C.

Om pumpen havererar, kontakta Varian reparationsverkstad eller Varian utbytesservice, som kan ersätta pumpen med en renoverad pump.

OBSERVERA

Innan pumpen lämnas in till tillverkaren för reparation eller utbyte mot en renoverad enhet, måste "hälsa- och säkerhetsbladet" som medföljer bruksanvisningen fyllas i och skickas in till den lokala återförsäljaren. Bifoga dessutom en kopia av bladet med pumpen.

Skrotning av pumpen skall ske enligt gällande lagstiftning.

GENERELL INFORMASJON

Dette utstyret er beregnet til bruk av profesjonelle brukere. Brukeren bør lese denne brukerveiledningen og all annen informasjon fra Varian før utstyret tas i bruk. Varian kan ikke holdes ansvarlig for hendelser som skjer på grunn av manglende oppfølging av disse instruksjonene, selv delvis, feilaktig bruk av utrent personell, ikke autoriserte endringer av utstyret eller handlinger som på noen måte er i strid med nasjonale bestemmelser.

Turbo-V1000 ICE serien med pumper er turbo-molekulære pumper for bruk i høy- eller ultrahøye vakuumanlegg innenfor halvlederindustrien, og kan pumpe nesten alle typer gass eller gassforening. De er ikke beregnet for å pumpe væsker eller faste partikler.

Pumpingen oppnås med en høyhastighetsturbin (maks. 38000 rpm) koplet til en trefaset elektrisk motor. Turbo-V1000 ICE pumper har ingen forurensende stoffer og er derfor egnet for anlegg med behov for "rene" vakuum.

De følgende avsnitt inneholder all informasjon som er nødvendig for å sikre brukeren når utstyret er i bruk. For mer detaljert bruk vises det til tillegget "Teknisk informasjon".

Denne manualen bruker følgende standardprotokoll:



ADVARSEL!

Disse meldingene skal tiltrekke seg brukerens oppmerksomhet til en spesiell fremgangsmåte eller praksis som, hvis den ikke følges, kan medføre alvorlige skader.



FORSIKTIG !

Denne advarselen vises foran fremgangsmåter som, dersom de ikke følges, kan føre til at utstyret skades.

MERK

Merknadene inneholder viktig informasjon som er hentet fra teksten.

LAGRING

Når pumpene transporteres eller lagres, må følgende miljømessige krav oppfylles:

- temperatur: fra -20°C til +70°C
- relativ fuktighet: 0 - 95% (uten kondens)

Skal utstyret lagres lengre, må pumpen MYKSTARTES (se kontrollenhetens manual).

KLARGJØRE TIL INSTALLASJON

Pumpen leveres i en spesiell beskyttelsesemballasje. Viser denne tegn på skader som kan ha oppstått under transporten, må du ta kontakt med det lokale salgskontoret.

Når pumpen pakkes ut, må du se til at den ikke slippes ned eller utsettes for noen form for støt.

Emballasjen må ikke kastes på en ulovlig måte. Alle materialer er 100% resirkulerbare og er i samsvar med EU-direktiv 85/399 om miljøbeskyttelse.



FORSIKTIG !

For å unngå avgassingsproblemer, må ingen del som skal utsettes for vakuum håndteres med bare hendene. Bruk alltid hansker eller andre og passende verneutstyr.

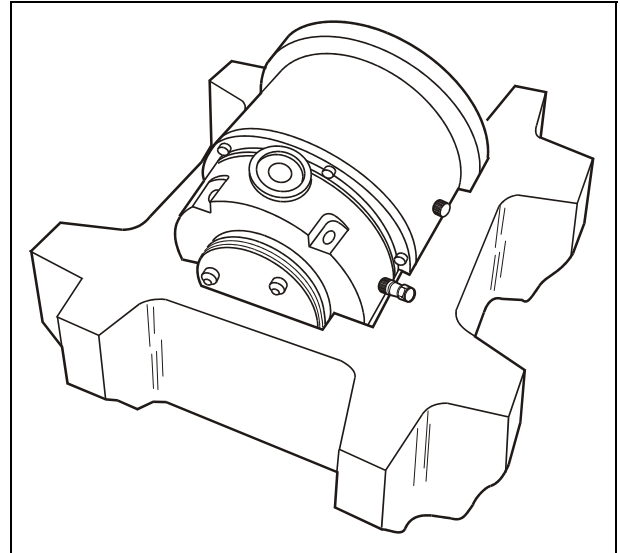

MERK

Normale miljømessige belastninger kan ikke ødelegge pumpen. Likevel anbefaler vi å holde den lukket til den er montert i systemet, slik at den ikke forurenses eller utsettes for nedstøving.

INSTALLASJON



ADVARSEL!

Med tanke på pumpens vekt skal den bare håndteres ved bruk av dertil egnede løfte- og flyttingsanordninger.

Ikke installer eller bruk pumpen i miljøer som utsettes for regn, snø eller is, støv, aggressive gasser, eksplosjonsfarlige miljøer eller miljøer med stor brannfare.

Under bruk må følgende forhold respekteres:

- maksimalt trykk: 2 bar (over atmosfærisk trykk)
- temperatur: fra +5°C til +35°C
- relativ fuktighet: 0 - 95% (uten kondens).



FORSIKTIG !

Fjern tapen og ta ut beskyttelsesproppen først når turbopumpen skal sluttes til systemet.

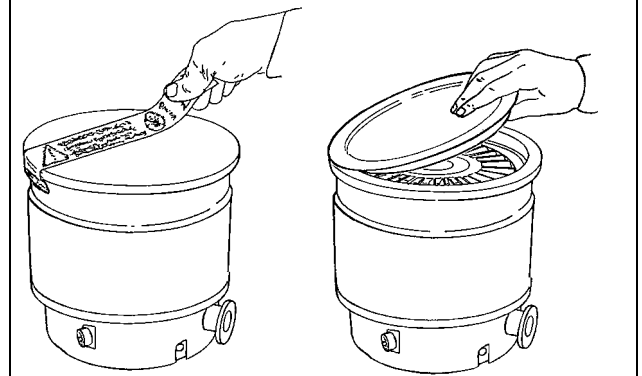

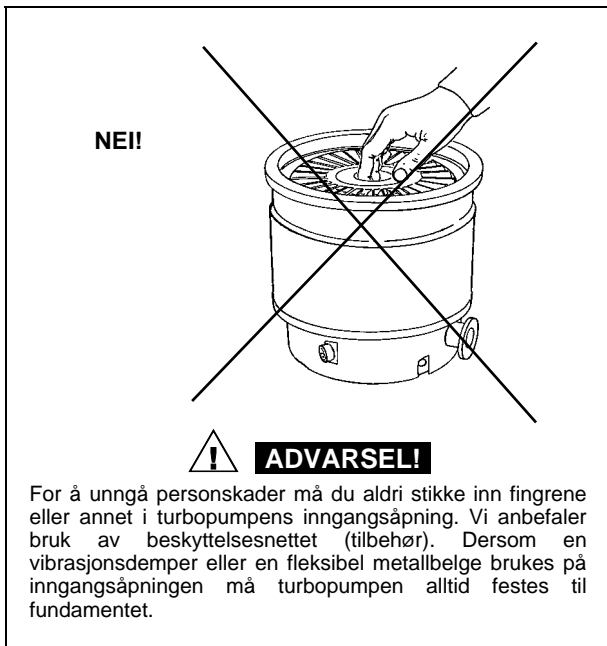

Ved magnetfelt må pumpen beskyttes av dertil egnede skjermer. Se "Teknisk informasjon" for detaljer.

Turbo-V1000 ICE serien turbo-molekulære pumper må kun brukes med en av de spesielle Varian kontrollere (serie 969-9447, 969-9547), og må koples til hovedpumpen (se skjema i "Teknisk informasjon").

Turbopumpen kan monteres i en valgfri stilling. Fest turbopumpen i en stabil stilling med inngangsfleksen festet mot en koplingsflens med et dreiemoment på 4668 Nm rundt akselen. Turbopumpene med ISO innløpsflens skal festes til vakuumkanmeret med dobbel eller enkle klemmer. Følgende tabell angir det nødvendige antall klemmer og det relevante strammemomentet for de enkelte flensdimensjonene og typer klemmer.

FLENS	TYPE KLEMME	ANT.	STRAMME-MOMENT
ISO 200	Dobbel klemme, gjenge M10	6	23 Nm
	Enkel klemme, gjenge M10	6	23 Nm

For å feste pumpen til fundamentet er det nødvendig å bruke tre M6-skruer, som skrues fast i hullene på pumpens fundament. Skruene skal klare en belastning på 550 N/mm². Skruenes riktige strammemoment er 4,5 Nm. For installasjon av tilleggsstyr vises det til "Teknisk informasjon".

BRUK

Alle instruksjoner for korrekt bruk av turbopumpen finnes i kontrollenshetens manual.

Les nøye gjennom denne manualen før pumpen tas i bruk.

For å øke trykkgrensene kan pumpehuset varmes opp med en varmer som kan fås som ekstrautstyr. Mens oppvarmingen av kammeret pågår må temperaturen ved inngangsfleksen ikke overskride 120°C.

Bruk alltid vannavkjøling under oppvarmingen.



ADVARSEL!

Ikke berør turbopumpen eller noe av tilleggsutstyret under oppvarmingen. De høye temperaturene kan føre til brannskader.



FORSIKTIG!

Bruk støv- og partikkelfri luft eller inaktiv gass ved lufting av pumpen. Trykket ved inngangen må ikke være mindre enn 2 bar (over atmosfærisk trykk).



FORSIKTIG!

Unngå støt, svingninger eller plutselige bevegelser av turbinpumpen når den er i funksjon. Lagrene kan skades.



FORSIKTIG!

Ved pumping av etsende gasser er disse pumpene utstyrt med en spesiell åpning. Til denne åpningen skal flyt av inaktive gasser (argon eller kvelstoff) koples for å beskytte lagrene (se "Teknisk informasjon").



ADVARSEL!

Når pumpen brukes for å pumpe giftige, brannfarlige eller radioaktive gasser skal de relevante forskriftene for de enkelte gasstypene følges.

Pumpen skal ikke brukes i eksplosjonsfarlige miljøer.

VEDLIKEHOLD

Turbo-V1000 ICE serien pumper er vedlikeholdsfrie. Alt arbeid på pumpen må kun utføres av autorisert personell.



ADVARSEL!

Før noe arbeid gjøres på turbopumpen må den frakoples tilførselen, den må luftes ved å åpne den aktuelle ventilen og deretter vente til rotoren har stanset og pumpens overflatetemperatur er lavere enn 50°C.

Dersom pumpen stanser, må du ta kontakt med Varians reparasjonsservice eller med Varians avanserte bytteservice som kan tilby overholte pumper til erstatning for den ødelagte pumpen.

MERK

Før pumpen returneres til produsenten for reparasjon, eller som innbytte for en overholt pumpe, må det vedlagte skjemaet "Helse og sikkerhet" fylles inn og sendes til det lokale salgskontoret. En kopi av dette arket må vedlegges pumpen som sendes tilbake.

Dersom en pumpe skal kasseres, må dette skje i henhold til nasjonale bestemmelser.

YLEISIÄ TIETOJA

Tämä laite on tarkoitettu ammattimaiseen käyttöön. Ennen laitteen käyttöönottoa tulee käyttäjän lukea huolellisesti mukana seuraava käyttöohje sekä kaikki muu Varianin toimittama lisätieto. Varian ei ota vastuuta seurauksista, jotka johtuvat laitteen käyttöohjeiden täydestä tai osittaisesta laiminlyönnistä, ammattitaidottoman henkilön virheellisestä laitteen käytöstä, valtuuttamattomista toimenpiteistä tai kansallisen lainsäädännön vastaisesta käytöstä.

Turbo-V1000 ICE sarjan pumput ovat turbomolekyylipumppuja, jotka on tarkoitettu korkean ja ultrakorkean tyhjiön muodostamiseen. Ne sopivat erityisen hyvin puolijohteita käyttävän teollisuuden käyttöön ja soveltuvat kaikentyyppisien kaasujen tai kaasuseosten pumppaamiseen. Ne eivät sovellu nesteiden tai kiinteiden hiukkasten pumppaukseen.

Pumppaus saadaan aikaan korkealla nopeudella (38000 kierrosta/min. max) pyörivän turbiinin avulla, jonka korkeatehoinen kolmivaiheinen sähkömoottori käynnistää. Turbo-V1000 ICEsarjan pumpuissa ei ole lainkaan liikaavia aineita, joten ne soveltuvat myös "puhdasta" tyhjiötä vaativiin käyttötarpeisiin.

Seuraavilla sivuilla on luettavissa kaikki tarpeellinen tieto laitteen käyttäjän turvallisuuden takaamiseksi laitteen käytön aikana. Yksityiskohtaista tietoa saa osasta "Technical Information".

Tämä käsikirja käyttää seuraavanlaisia merkintöjä:



VAARA!

Vaara-merkit saavat käyttäjän kiinnittämään huomion erityiseen käyttö- tai toimintatapaan, joiden vääränlainen suoritus voi johtaa vakaviin henkilövaurioihin.



HUOMIO!

Huomio-merkit ovat nähtävissä ennen toimintatapoja, joiden laiminlyönti voi johtaa laitteen vahingoittumiseen.

HUOMAUTUKSET

Huomautuksissa käyvät ilmi tekstissä käsitellyt tärkeät tiedot.

VARASTOINTI

Pumppujen kuljetuksen ja varastoinnin aikana täytyy seuraavien ympäristöä koskevien ehtojen olla täytettyinä:

- lämpötila: - 20°C - +70°C
- suhteellinen kosteus: 0 - 95% (ei tiivistävä)

Jos varastointiaika on hyvin pitkä, tulee pumppu käynnistää SOFT START-tavalla (katso valvojan käyttökirja).

VALMISTELUT ASENNUSTA VARTEN

Pumpun toimitus tapahtuu erityisessä suojaavassa pakkauksessa; mikäli havaittavissa on mahdollisesti kuljetuksen aikana tapahtuneita vaurioita, ottakaa yhteys paikalliseen myyntitoimistoon..

Pakkauksen purkamisen aikana tulee varoa erityisesti pumpun putoamista tai siihen kohdistuvia iskuja.

Pakkausta ei tule jättää ympäristöön. Pakkausmateriaali on täysin kierrätettävä ja se vastaa EEC 85/399 direktiiviä ympäristön suojelusta.



HUOMIO!

Jotta kaasun poistumisongelmilta vältyttäisiin, ei tyhjiön tarkoitettuihin osiin tule koskea paljain käsin. Hanskojen tai muun sopivan suojan käyttö on tarpeellinen.

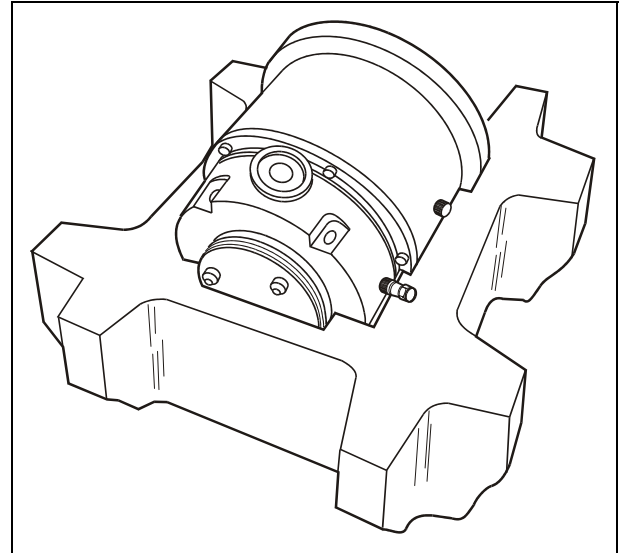

HUOMAUTUS

Pumppu ei vahingoitu sen ollessa yksinkertaisesti avoinna. On kuitenkin suositeltavaa pitää se suljettuna kunnes se kytketään järjestelmään, jotta vältettäisiin sen mahdollinen saastuminen pölyltä.

ASENNUS



VAARA!

Ajatellen pumpun painoa, tätä tulee käsitellä ainoastaan siihen tarkoitettulla nosto- ja siirtolaitteiston avulla.

Pumppua ei tule asentaa eikä käyttää ympäristössä, missä se joutuu kosketuksiin sateen, jään tai lumen, pölyn tai aggressiivisten kaasujen kanssa tai joissa on olemassa räjähdys- tai tulipalovaara.

Käytön aikana on tarpeellista noudattaa seuraavia ympäristöä koskevia ehtoja:

- maksimipaine: 2 bar, paitsi atmosfäärinen paine
- lämpötila: + 5°C - +35°C
- suhteellinen kosteus: 0 - 95 % (ei tiivistävä).



HUOMIO!

Poista tarra ja irrota suojakorkki vasta silloin, kun yhdistät turbopumpun järjestelmään.

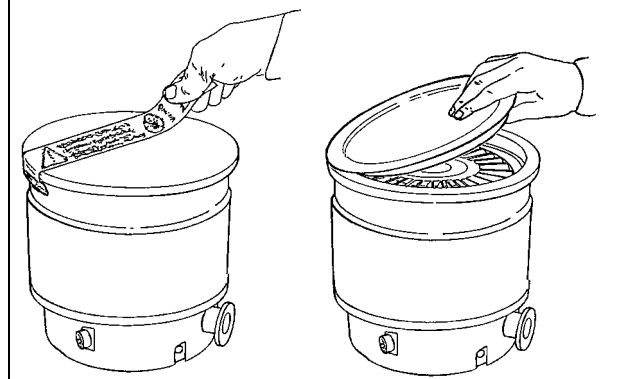



Mikäli magneettikenttjä on läsnä pumpun tulee suojata tähän tarkoitukseen olevilla suojilla. Lisätietoja löytyy "Technical Information"-liitteestä.

Sarjan V1000-ICE turbomolekyylipumpuja tulee käyttää ainoastaan niihin sopivien varian valvojen kanssa (sarja 969-9447, 969-9547) ja niiden täytyy olla yhdistettyinä pääpumpuun (katso kaaviota osasta "Technical Information"). Turbopumpun voidaan asentaa mihin tahansa asentoon. Turbopumpun tulee kiinnittää vakaaseen asentoon liittämällä turbopumpun sisääntulolaippa kiinteään vastalaippaan, joka kantaa 4668 Nm momenttia akselinsa ympärillä, tai käyttäen tarkoitukseen sopivia lisävarusteita sen kiinnittämiseen. Turbopumpun ISO sisääntulolaipalla tulee kiinnittää tyhjiökammariin kaksois kiinnikkeillä tai yksinkertaisilla kiinnikkeillä. Seuraava taulukko kuvaa kaikki laippakoot ja kiinnikemallit, kiinnikkeiden tarpeellisen määrän ja kiristysmomentti

LAIPPA	KIINNIKE	MÄÄRÄ	KIRISTYS-MOMENTTI
ISO 200	Kaksoiskiinnike, kierteitys M10	6	23 Nm
	Yksinkertainen kiinnike, kierteitys M10	6	23 Nm

Pumpun tulee kiinnittää jalustan avulla käyttäen kolmea M6 ruuvia jotka on kiinnitetty sopiviin pumpun jalustassa oleviin rakoihin. Ruuveilla tulee olla venytysrasitus joka vastaa 550 N/mm², ja tulee kiinnittää 4,5 Nm momentilla. Lisälaitteiden asennuksen ohjeet ovat nähtävissä "Technical Information" osassa.

KÄYTTÖ

Turbopumpun oikeaoppiseen käyttöön tarvittavat ohjeet löytyvät valvojan käsikirjasta.

Lukekaa huolellisesti kyseinen käsikirja ennen käyttöönottoa. Parempien rajapaineiden saavuttamiseksi pumpun kotelo voidaan kuumentaa käyttämällä lisätalouksesta saatavaa kuumenninta. Tyhjiökammion mahdollisen kuumentamisen aikana ei sisäänjohtavan laipan lämpötila saa olla yli 120 °C. Käyttäkää aina kuumentamisen aikana vettä jäähdytykseen.



VAARA!

Älkää koskeko turbopumpun tai sen lisäosien kuumentamisen aikana. Korkea lämpötila voi saada aikaan henkilöiden loukkaantumisia.



HUOMIO!

Päästettäessä pumpuun ilmaa tulee käyttää ilmaa tai jalokaasua, joissa ei ole pölyä tai hiukkasia. Sisäänjohtavan paineen siihen sopivan aukon läpi täytyy olla alle 2 bar:ia (paitsi atmosfäärinen paine).



HUOMIO!

Vältä kolhuja, heiluntaa tai äkkiliikkeitä turbopumpun toiminnan aikana, sillä laakerit voivat vahingoittua.



HUOMIO!

Aggressiivisten kaasujen pumpusta varten nämä pumput on varustettu sopivalla aukolla jonka läpi tulee kuljettaa pumpuun ei-aktiivisia kaasuja (typpi tai argooni) jotta laakerit suojataan (katso liite "Technical information").



VAARA!

Jolloin pumpua käytetään myrkyllisten, tulenvarallisten ja radioaktiivisten kaasujen pumpaamiseen tulee seurata joka kaasuun sopivaa menettelytapaa. Älkää käytä pumpua räjähdysherkkien kaasujen lähellä.

HUOLTO

Sarjan Turbo-V1000 ICE pumput eivät vaadi lainkaan huoltoa. Minkä tahansa toimenpiteen täytyy suorittaa siihen valtuutettu henkilö.



VAARA!

Ennen minkään tyypistä toimenpidettä ottaa pois päältä verkkovirta, päästäkää pumpuun ilmaa avaten siihen tarkoitettu venttiili ja odottakaa roottorin täydellistä pysähtymistä ja että pumpun pintalämpö on alle 50°.

Laitteen vahingoittuessa on mahdollista käyttää Varianin korjauspalvelua tai "Varian advanced exchange service", joka mahdollistaa regeneroidun pumpun saamisen vahingoittuneen tilalle.

HUOMAUTUS

Ennen pumpun lähettämistä valmistajalle korjausta tai advanced exchange serviceä varten, on ehdottomasti täytettävä ja toimitettava paikalliseen myyntitoimistoon "Turvallisuus ja Terveys"-kaavake, joka löytyy liitteenä ohjekirjan mukana. Kyseisen kaavakkeen kopio tulee liittää pumpun pakkaukseen ennen sen lähettämistä.

Mikäli pumpun täytyy romuttaa, toimikaa kansallisen lainsäädännön määräämällä tavalla.

ΓΕΝΙΚΕΣ ΠΛΗΡΟΦΟΡΙΕΣ

Αυτή η συσκευή προορίζεται για επαγγελματική χρήση. Ο χρήστης θα πρέπει να διαβάσει προσεκτικά τις οδηγίες του παρόντος εγχειρίδιου και οποιαδήποτε άλλη πρόσθετη πληροφορία που δίνει η Varian, πριν από τη χρησιμοποίηση της συσκευής.

Η Varian δεν φέρει καμία ευθύνη όσον αφορά την ολική ή μερική αθέτηση των οδηγιών, την ακατάλληλη χρήση εκ μέρους ανεκπαίδευτου προσωπικού, αυθαίρετες επεμβάσεις ή χρήση που δεν συμφωνεί με τους ειδικούς εθνικούς κανονισμούς.

Οι αντλίες της σειράς Turbo-V1000ICE είναι στροβιλομοριακές αντλίες για εφαρμογές υψηλού και πολύ υψηλού κενού, ιδιαίτερα κατάλληλες για τη χρήση σε τομείς που συνδέονται με τη βιομηχανία των ημιαγωγών και είναι ικανές να αντλήσουν κάθε είδους αέριο ή αεριούχο συστατικό. Είναι ακατάλληλες για την άντληση υγρών ή στερεών σωματιδίων.

Η άντληση επιτυγχάνεται διαμέσου μίας τουρμπίνας που περιστρέφεται με μεγάλη ταχύτητα (το ανώτερο 38000 σ.α.λ.), η οποία κινείται από ένα τριφασικό ηλεκτρικό μοτέρ υψηλής απόδοσης. Οι αντλίες Turbo-V1000 ICE δεν περιέχουν ρυπαντικούς παράγοντες, είναι κατάλληλες λοιπόν και για εφαρμογές που απαιτούν ένα άκαθαρό κενό.

Στις επόμενες παραγράφους αναφέρονται όλες οι απαραίτητες πληροφορίες που εγγυούνται την ασφάλεια του χειριστή κατά τη διάρκεια της χρησιμοποίησης της συσκευής. Λεπτομερείς πληροφορίες δίνονται στο παράρτημα «Τεχνικές Πληροφορίες».

Αυτό το εγχειρίδιο χρησιμοποιεί τις ακόλουθες συμβάσεις:

**ΚΙΝΔΥΝΟΣ!**

Οι ενδείξεις κινδύνου ελκύουν την προσοχή του χειριστή σε μία διαδικασία ή σε μία ειδική εργασία η οποία αν δεν εκτελεστεί σωστά, θα μπορούσε να προκαλέσει σοβαρές προσωπικές βλάβες.

**ΠΡΟΣΟΧΗ**

Οι ενδείξεις προσοχής εμφανίζονται πριν από τις διαδικασίες οι οποίες αν δεν εκτελεστούν με προσοχή, θα μπορούσαν να προκαλέσουν ζημιές στη συσκευή.

ΣΗΜΕΙΩΣΗ

Οι σημειώσεις περιέχουν σημαντικές πληροφορίες που έχουν αποσπαστεί από το κείμενο.

ΑΠΟΘΗΚΕΥΣΗ

Κατά τη διάρκεια της μεταφοράς και της αποθήκευσης των αντλιών πρέπει να τηρούνται οι ακόλουθες περιβαλλοντικές συνθήκες:

- θερμοκρασία: από -20°C μέχρι +70°C
- σχετική υγρασία: 0 - 95% (ασυμπύκνωτη)

Αν ο χρόνος αποθήκευσης είναι πολύ μακρύς, η αντλία θα πρέπει να τεθεί σε κίνηση με τρόπο SOFT START (βλέπε το εγχειρίδιο της μονάδας ελέγχου).

ΠΡΟΕΤΟΙΜΑΣΙΑ ΓΙΑ ΤΗΝ ΕΓΚΑΤΑΣΤΑΣΗ

Η αντλία προμηθεύεται μέσα σε μία ειδική προστατευτική συσκευασία. Αν υπάρχουν ενδείξεις βλάβης που θα μπορούσαν να έχουν προκληθεί κατά τη διάρκεια της μεταφοράς, συμβουλευτείτε το τοπικό τμήμα πωλήσεων.

Κατά τη διάρκεια του ανοίγματος της συσκευασίας, δώστε ιδιαίτερη προσοχή έτσι ώστε να μην πέσει και να μην χτυπηθεί η αντλία.

Μην εγκαταλείπετε τη συσκευασία στο περιβάλλον. Το υλικό ανακυκλώνεται πλήρως και ανταποκρίνεται στην Οδηγία της Ε.Ο.Κ. 85/399 για την διαφύλαξη του περιβάλλοντος.

**ΠΡΟΣΟΧΗ**

Προκειμένου να αποφύγετε προβλήματα από την απελευθέρωση αερίου, μην αγγίζετε με γυμνά χέρια τα τμήματα που πρόκειται να εκτεθούν στο κενό. Να χρησιμοποιείτε πάντα γάντια ή άλλη κατάλληλη προστασία.

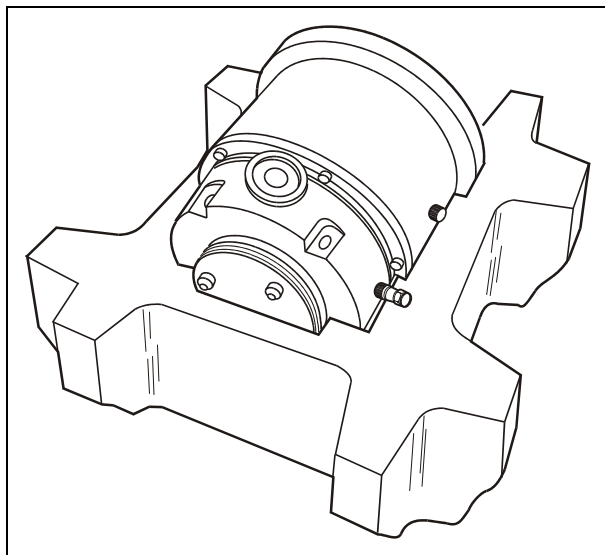
**ΣΗΜΕΙΩΣΗ**

Η αντλία δεν καταστρέφεται αν απλώς εκτεθεί στον ατμοσφαιρικό αέρα. Σας συμβουλεύουμε όμως να την κρατήσετε κλειστή μέχρι τη στιγμή που θα εγκατασταθεί στο σύστημα, έτσι ώστε να αποφευχθεί η ενδεχόμενη ρύπανση από τη σκόνη.

ΕΓΚΑΤΑΣΤΑΣΗ**ΚΙΝΔΥΝΟΣ!**

Η αντλία, λόγω του βάρους της, πρέπει να μετακινηθεί διαμέσου ειδικών εργαλείων ανύψωσης και μετακίνησης.

Η αντλία δεν θα πρέπει να εγκατασταθεί καιδή να χρησιμοποιηθεί σε χώρους εκτεθειμένους σε ατμοσφαιρικούς παράγοντες (βροχή, πάγο, χιόνι), σκόνης, πολεμικά αέρια, σε χώρους όπου υπάρχει κίνδυνος έκρηξης ή κίνδυνος πυρκαγιάς. Κατά τη διάρκεια της λειτουργίας πρέπει να τηρούνται οι ακόλουθες συνθήκες περιβάλλοντος:

- μέγ. πίεση: 2 bar πάνω από την ατμοσφαιρική πίεση
- θερμοκρασία: από + 5°C μέχρι + 35°C
- σχετική υγρασία: 0 - 95 % (ασυμπύκνωτη).

**ΠΡΟΣΟΧΗ**

Ξεκολλήστε το αυτοκόλλητο και βγάλτε το προστατευτικό καπάκι μόνο τη στιγμή της σύνδεσης της τουρμποαντλίας στο σύστημα.

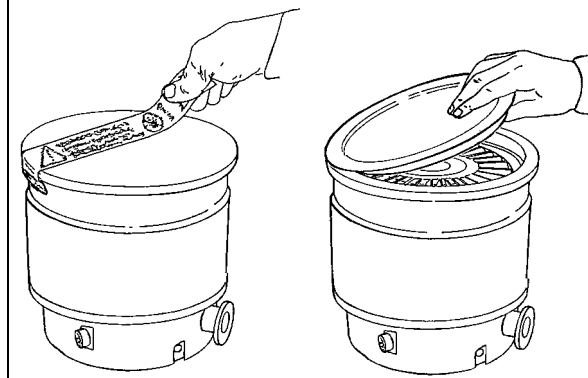

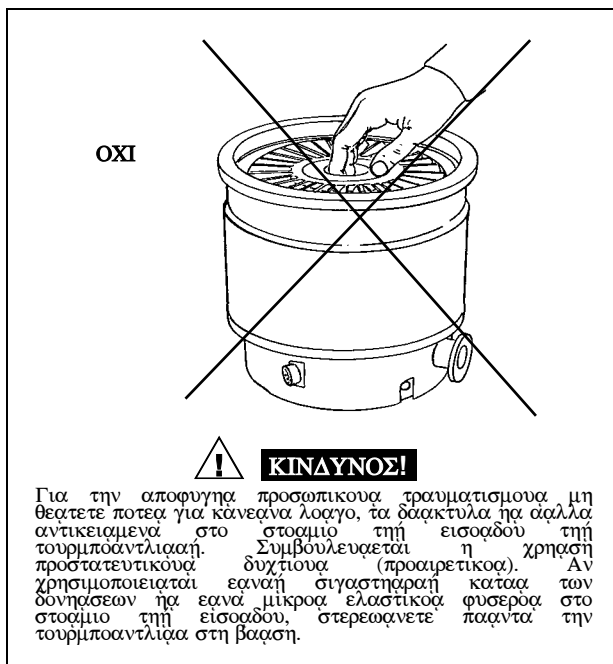

Σε παρουσία ηλεκτρομαγνητικών πεδίων η αντλία πρέπει να προστατεύεται με κατάλληλα προκαλύμματα. Βλέπε το παράρτημα «Τεχνικές Πληροφορίες» για περισσότερες λεπτομέρειες.

Οι τουρμποαερακτικές αντλίες της σειράς Turbo-V1000ICE πρέπει να χρησιμοποιούνται μόνο με έναν από τους ειδικούς ελεγκτές Varian (σειρές 969-9447, 969-9547) και πρέπει να είναι συνδεδεμένες με μία πρωτεύουσα αντλία (βλέπε σχήμα στις «Τεχνικές Πληροφορίες»).

Η τουρμποαντλία μπορεί να εγκατασταθεί σε οποιαδήποτε θέση. Στερεώστε την τουρμποαντλία σε σταθερή θέση ενώ τοντας τη φλάντζα εισόδου με μία σταθερή κόντροφλάντζα ικανή να αντισταθεί σε ένα ζεύγος 4668 Nm γύρω από τον άξονά της.

Η τουρμποαντλία με φλάντζα εισόδου ISO πρέπει να στερεωθεί στον θάλαμο κενού μέσω διπλών ή μονών δαγκάνων. Η ακόλουθη ταμπέλλα περιγράφει τον απαραίτητο αριθμό δαγκάνων και με ποιο ζεύγος βιδώματος πρέπει να σφικτούν.

ΦΛΑΝΤΖΑ	ΕΙΔΟΣ ΔΑΓΚΑΝΗΣ	N	ΖΕΥΓΟΣ ΒΙΔΩΜΑΤΟΣ
ISO 200	Διπλή δαγκάνη με ελκωτή προεξοχή M10	6	23 Nm
	Μονή δαγκάνη με ελκωτή προεξοχή M10	6	23 Nm

Για να στερεώσετε την αντλία μέσω της βάσης της είναι απαραίτητο να χρησιμοποιήσετε τρεις βίδες M6 στερεωμένες στις ειδικές οπές που υπάρχουν στη βάση της αντλίας. Οι χρησιμοποιούμενες βίδες πρέπει να έχουν αντοχή 500 Nδmm² και πρέπει να στερεωθούν με ένα ζεύγος 4,5 Nm.

Για την εγκατάσταση των προαιρετικών εξαρτημάτων, βλέπε «Τεχνικές Πληροφορίες».

ΧΡΗΣΗ

Όλες οι οδηγίες για για τη σωστή λειτουργία της τουρμποαντλίας περιέχονται στο εγχειρίδιο της μονάδας ελέγχου.

Διαβάστε προσεκτικά αυτό το εγχειρίδιο πριν από τη χρήση. Για να επιτύχετε καλύτερες οριακές πιέσεις μπορείτε να θερμάνετε το περιβάλλον της αντλίας χρησιμοποιώντας τον προαιρετικό θερμαντήρα. Κατά τη διάρκεια της ενδεχόμενης θέρμανσης του θαλάμου κενού η θερμοκρασία στη φλάντζα εισόδου δεν πρέπει να ξεπερνά τους 120°C. Κατά τη θέρμανση να χρησιμοποιείτε πάντα υγρή ψύξη.

! ΚΙΝΔΥΝΟΣ!

Μην αγγίζετε την τουρμποαντλία και τα διάφορα εξαρτήματά της κατά τις εργασίες θέρμανσης. Η υψηλή θερμοκρασία μπορεί να προκαλέσει προσωπικές βλάβες.

ΠΡΟΣΟΧΗ

Για να διοχετεύσετε με αέρα την αντλία χρησιμοποιήστε αέρα ή αδρανές αέριο καθαρό από σκόνη ή άλλα στοιχεία. Η πίεση εισόδου διαμέσου της ειδικής πόρτας, πρέπει να είναι μικρότερη από 2 bar (πάνω από την ατμοσφαιρική πίεση).

ΠΡΟΣΟΧΗ

Αποφραγστε συγκρουασειή, ολισθηρασειή ηα αποατομεή μετακινηρασειή τηη αντλιαστή τουαμπο οαταν βριασκειται σε λειτουργιαα. Θα μπορούσαν να παθουν ζημιαή τα κουζιναα.

ΠΡΟΣΟΧΗ

Για την άντληση πολεμικών αερίων αυτές οι αντλίες είναι εφοδιασμένες με μία ειδική θυρίδα μέσω της οποίας είναι αναγκαία η διοχέτευση αδρανούς αερίου (άζωτο ή αργόν) για την προστασία των ρουλεμάν (βλέπε παράρτημα «Τεχνικές Πληροφορίες»).

! ΚΙΝΔΥΝΟΣ!

Όταν η αντλία χρησιμοποιείται για την άντληση τοξικών, εύφλεκτων ή ραδιενεργών αερίων, ακολουθείστε τις κατάλληλες διαδικασίες ειδικά για το κάθε αέριο.

Μην χρησιμοποιείτε την αντλία παρουσίας εκρηκτικών αερίων.

ΣΥΝΤΗΡΗΣΗ

Οι αντλίες της κατηγορίας Turbo-V1000 ICE δε χρειάζονται καμία συντήρηση. Οποιαδήποτε επέμβαση πρέπει να γίνεται από εξουσιοδοτημένο προσωπικό.

! ΚΙΝΔΥΝΟΣ!

Πριν επιχειρήσετε οποιαδήποτε επέμβαση στην τουρμποαντλία, αποσυνδέστε το καλώδιο τροφοδοσίας, κάντε εξάερωση στην αντλία ανοίγοντας την ειδική βαλβίδα αναμένετε μέχρι την πλήρη ακινητοποίηση του ρότορα και περιμένετε μέχρι η θερμοκρασία της επιφάνειας της αντλίας να είναι κατώτερη από 50° C.

Σε περίπτωση βλάβης μπορείτε να απευθυνθείτε στο σέρβις επισκευών Varian ή στο "Varian advanced exchange service", που σας δίνει τη δυνατότητα να αντικαταστήσετε την χαλασμένη αντλία με μία άλλη ενισχυμένη.

ΣΗΜΕΙΩΣΗ

Πριν επιστρέψετε στον κατασκευαστή την αντλία για επισκευή ή για advanced exchange service, είναι απαραίτητο να συμπληρώσετε και να παρουσιάσετε στο τοπικό Γραφείο Πωλήσεων, το έντυπο «Σιγουριά και υγεία» συννημμένο στο παρόν εγχειρίδιο οδηγιών. Αντίγραφο του ίδιου εντύπου πρέπει να υπάρχει μέσα στη συσκευασία της αντλίας πριν από την αποστολή.

Όταν πλέον παύσει να λειτουργεί η αντλία θα πρέπει να καταστραφεί σύμφωνα με τους ειδικούς εθνικούς κανονισμούς.

GENERAL INFORMATION

This equipment is destined for use by professionals. The user should read this instruction manual and any other additional information supplied by Varian before operating the equipment. Varian will not be held responsible for any events occurring due to non-compliance, even partial, with these instructions, improper use by untrained persons, non-authorized interference with the equipment or any action contrary to that provided for by specific national standards.

The Turbo-V 1000 ICE series pumps are turbo-molecular pumps for high and ultra-high vacuum applications particularly suitable for use in semiconductor industry sector and can pump any type of gas or gas compound. They are not suitable for pumping liquids or solid particles. The pumping action is obtained through a high speed turbine (max. 38000 rpm) driven by a high-performance 3-phase electric motor. The Turbo-V 1000 ICE pumps are free of contaminating agents and, therefore, are suitable for applications requiring a "clean" vacuum.

The following paragraphs contain all the information necessary to guarantee the safety of the operator when using the equipment. Detailed information is supplied in the appendix "Technical Information".

This manual uses the following standard protocol:



WARNING!

The warning messages are for attracting the attention of the operator to a particular procedure or practice which, if not followed correctly, could lead to serious injury.



CAUTION

The caution messages are displayed before procedures which, if not followed, could cause damage to the equipment.

NOTE

The notes contain important information taken from the text.

STORAGE

When transporting and storing the pumps, the following environmental requirements should not be exceeded:

- temperature: from -20° to +70 °C
- relative humidity: 0 - 95% (non-condensing)

If the storage time is long start the pump using the SOFT START mode (see control unit manual).

PREPARATION FOR INSTALLATION

The pump is supplied in a special protective packing. If this shows signs of damage which may have occurred during transport, contact your local sales office.

When unpacking the pump, be sure not to drop it and avoid any kind of sudden impact or shock vibration to it.

Do not dispose of the packing materials in an unauthorized manner. The material is 100% recyclable and complies with EEC Directive 85/399.



CAUTION

In order to prevent outgassing problems, do not use bare hands to handle components which will be exposed to vacuum. Always use gloves or other appropriate protection.

NOTE

Normal exposure to the environment cannot damage the pump. Nevertheless, it is advisable to keep it closed until it is installed in the system, thus preventing any form of pollution by dust.

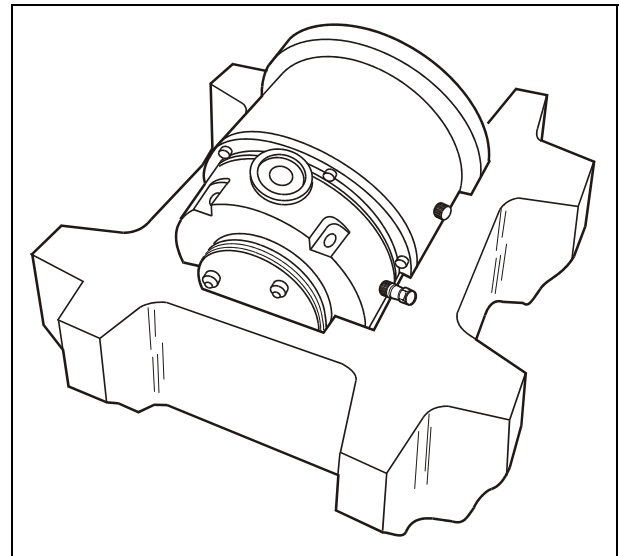

INSTALLATION



WARNING!

Due to its weight, the pump must be handled by means of suitable moving and handling tools.

Do not install or use the pump in an environment exposed to atmospheric agents (rain, snow, ice), dust, aggressive gases, or in explosive environments or those with a high fire risk. During operation, the following environmental conditions must be respected:

- maximum pressure: 2 bar above atmospheric pressure
- temperature: from +5 °C to +35 °C
- relative humidity: 0 - 95% (non-condensing)

In the presence of magnetic fields the pump must be protected using a ferromagnetic shield. See the appendix "Technical Information" for detailed information.



CAUTION!

Do not remove the adhesive and protective cap before connecting the turbopump to the system.

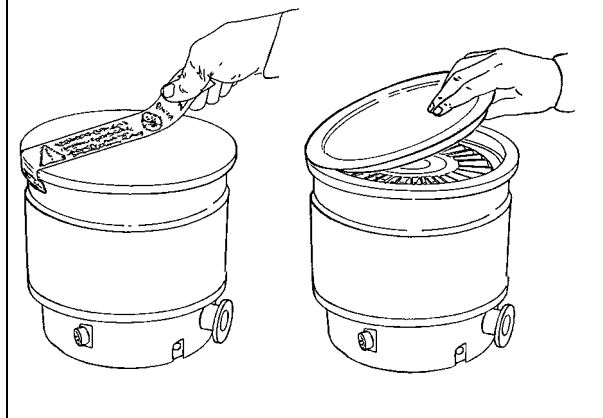

NO!

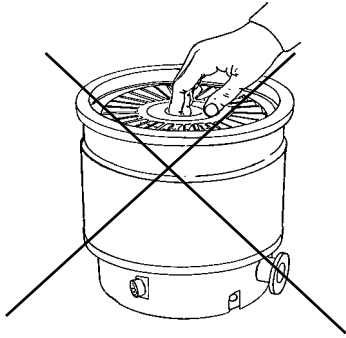

! WARNING!

To avoid injury, never put fingers or any objects whatsoever in the inlet port of the turbopump. The use of the protective screen is strongly advised (optional extra). If a vibration damper or flexible metallic bellows are used on the inlet port, make sure that the pump is fixed to the base.

The Turbo - V 1000 ICE series pumps must only be used with one of the special Varian controllers (series 969-9447, 969-9547) and must be connected to a primary pump (see "Technical Information").

The turbopump can be installed in any position. Fix the turbopump in a stable position connecting the inlet flange of the turbopump to a fixed counter-flange capable of withstanding a torque of 4668 Nm around its axis.

The turbopump with ISO inlet flange must be fixed to the vacuum chamber by means of clamps or claws. The following table shows, for each flange and fixing device, the necessary number of clamps or claws and the relevant fixing torque.

FLANGE	FIXING DEVICE	N.	FIXING TORQUE
ISO 200	M10 clamps	6	23 Nm
	M10 claws	6	23 Nm

The turbopump with ConFlat inlet flange must be fixed to the vacuum chamber by means of the appropriate Varian hardware.

To fix the pump by means of its base, it is necessary to use three M6 screws fixed to the foreseen holes of the pump base. The used screws must have a minimum strength point of 550 N/mm² and must be fixed with a torque of 4.5 Nm.

For installation of optional accessories, see "Technical Information".

USE

All the instructions for the correct use of the turbopump are contained in the control unit manual.

Read the manual carefully before using the pump. In order to achieve a better (lower) base pressure, the pump casing may be heated using the optional heater. While heating the pump, the temperature of its inlet flange must not exceed 120 °C. Always use the water cooling system during the heating operations.

! WARNING!

Do not touch the turbopump or any of its accessories during the heating process. The high temperatures may cause burns.

! CAUTION

Use air or inert gas free from dust or particles for venting the pump. The pressure at the vent port must be less than 2 bar (above atmospheric pressure).

! CAUTION

Avoid impacts, oscillations or harsh movements of the pump when in operation. The bearings may become damaged.

! CAUTION

For pumping aggressive gases, these pumps are fitted with a special port to allow a steady flow of inert gas (like N₂, Ar) for pump bearing protection (see the appendix "Technical Information").

! WARNING!

When employing the pump for pumping toxic, flammable, or radioactive gases, please follow the required procedures for each gas disposal.

Do not use the pump in presence of explosive gases.

MAINTENANCE

The Turbo-V 1000 ICE series pump does not require any maintenance. Any work performed on the pump must be carried out by authorized personnel.

! WARNING!

Before carrying out any work on the turbopump, disconnect it from the supply, vent the pump by opening the appropriate valve, wait until the rotor has stopped turning and wait until the surface temperature of the pump falls below 50 °C.

In the case of breakdown, contact your local Varian service center who can supply a reconditioned pump to replace that broken down.

NOTE

Before returning the pump to the constructor for repairs, or replacement with a reconditioned unit, the "Health and Safety" sheet attached to this instruction manual must be filled-in and sent to the local sales office. A copy of the sheet must be inserted in the pump package before shipping.

If a pump is to be scrapped, it must be disposed of in accordance with the specific national standards.

DESCRIPTION OF THE TURBOPUMP

The Turbo-V1000 ICE pump is available with an ISO 200 inlet flange (model 969-9080), or with a CFF 10" inlet flange (model 969-9100).

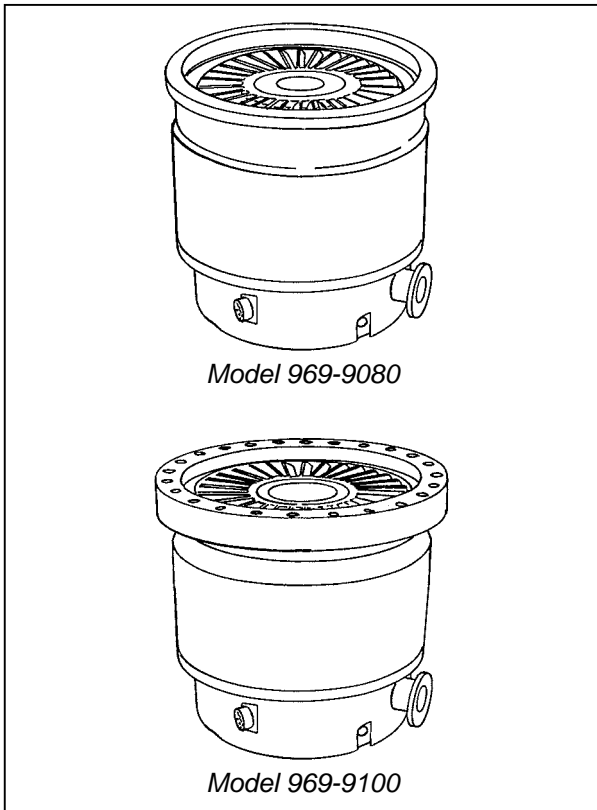

The Turbo-V1000 ICE pump consists of a high frequency motor driving a turbine fitted with 8 bladed stages and 4 Macrotrorr stages. The turbine rotates in an anticlockwise direction when viewed from the high vacuum flange end.

The turbine is made of high-strength, light aluminium alloy, and is machined from a single block of aluminium. The turbine stages have six different angles, from 44° to 16°, while the Macrotrorr stages are in form of discs.

The turbine rotor is supported by permanently lubricated high precision ceramic ball bearings installed on the forevacuum side of the pump.

The static blades of the stator are made of stainless steel with five different blade angles from 44° to 16°. These are supported and accurately positioned by spacer rings.

The Macrotrorr stators are in the form of self-positioning machined discs with pumping channels and an opening restricted by the corresponding rotor discs. These are made of aluminium alloy.

The Spiral Seal is a dynamic seal based on a Siegbahn disk that increases the protection of the bearings against corrosive gases.

The aluminium parts are protected against corrosion caused by chlorinated and fluorinated gases by means of a protective film. The film (called Armor Coating) is deposited by means of a vacuum process allowing an uniformity of the coating thickness with no impact on the pump balance.

During normal operation, the motor is fed with a voltage of 56 Vac three-phase at 633 Hz. To reduce losses during start-up to a minimum, the frequency increases according to a ramp with a higher initial voltage/frequency ratio.

A water cooling kit is available to cool the pump in the cases where it is used under heavy load or when forced air is insufficient for cooling purposes.

Two thermistor sensors are mounted near the upper and the lower bearings to prevent the pump from overheating. The thermistor sensors, the motor stator windings and the earth are connected to a Turbo-V controller through a 8 pin socket on the side of the pump. An M5 hole in the pump envelope is provided to install an accelerometer for diagnostic purposes.

The pump is balanced after assembly with a residual vibration amplitude less than 0.01 µm.

The pump can operate in any position and can be supported on the high vacuum flange or on its base. The connection of the forevacuum on the side of the pump is a KF 40 flange.

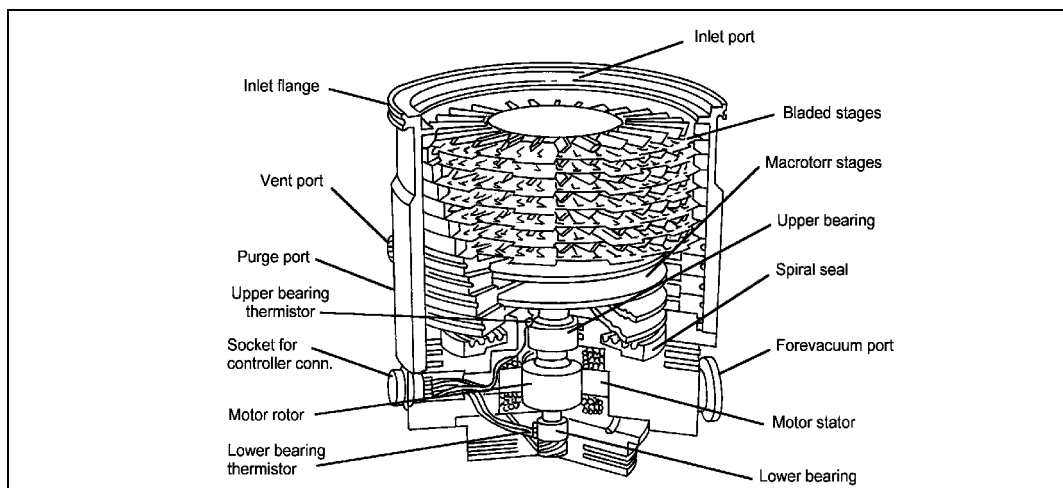

TECHNICAL SPECIFICATION

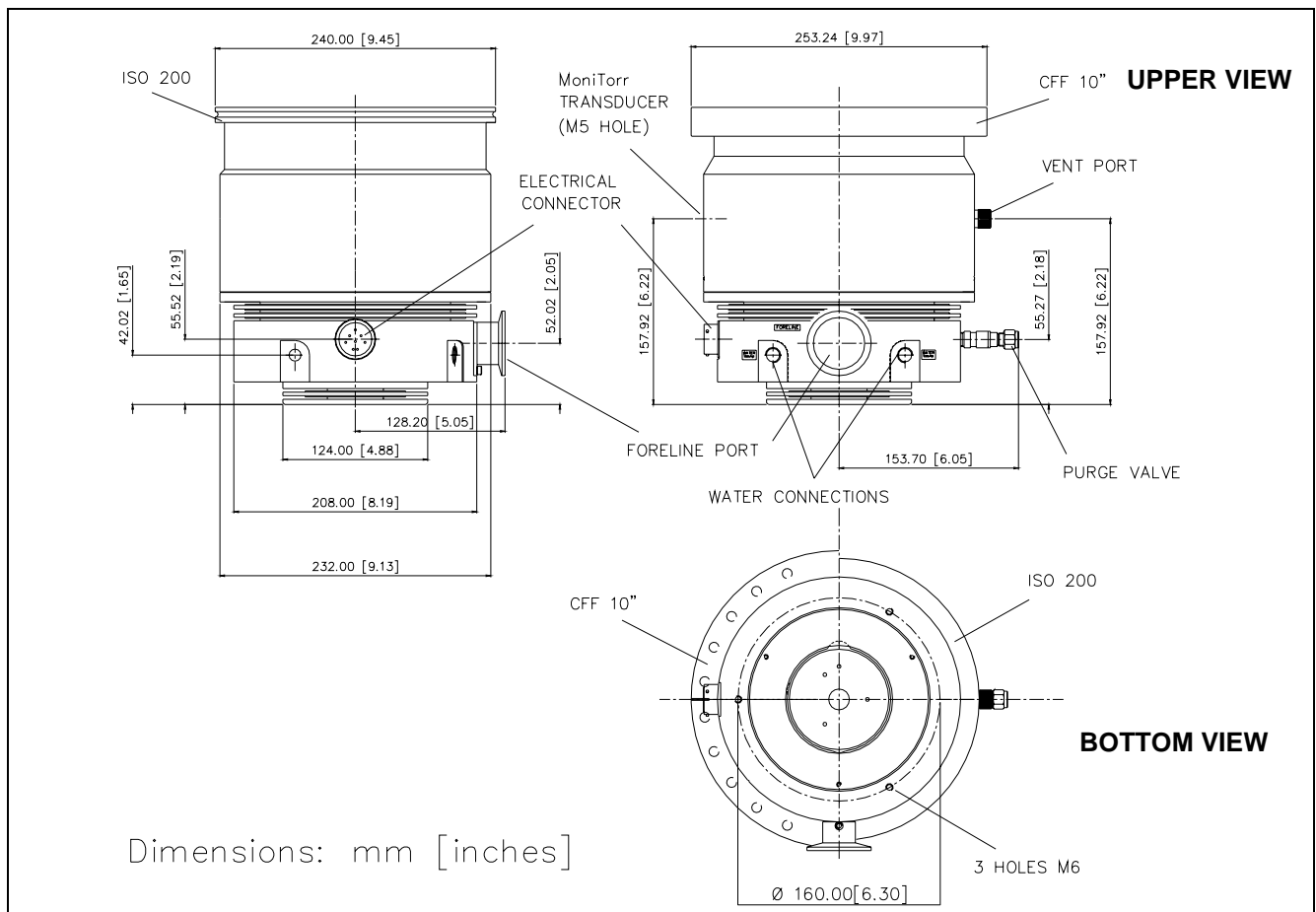

Pumping speed	N ₂ : 950 l/s He: 870 l/s H ₂ : 900 l/s
Compression ratio	N ₂ : >1 x 10 ¹⁰ He: 5 x 10 ⁷ H ₂ : 2 x 10 ⁶
Base pressure*	minimum with recommended mechanical forepump: < 1 x 10 ⁻⁹ mbar (< 1 x 10 ⁻⁹ Torr) minimum with recommended diaphragm forepump: 2 x 10 ⁻⁸ mbar (1.5 x 10 ⁻⁸ Torr)
Inlet flange	ISO 200; CFF 10"
Foreline flange	KF 40 NW
Rotational speed	38000 RPM
Start-up time	< 4 minutes
Recommended forepump	mechanical: Varian DS 402 diaphragm: Varian MD 60
Operating position	any
Cooling requirements	Water (use water with electrical conductivity ≤ 500 μS/cm)

Operating ambient temperature	+ 5° C to + 35° C
Coolant water	minimum flow: 200 l/h (0.89 GPM) temperature: + 10° C to + 20° C pressure: 3 to 5 bar (45 to 75 Psi)
Bakeout temperature	80° C at inlet flange (with ISO flange) 120° C at inlet flange (with CF flange)
Vibration level (displacement)	< 0.01 μm at inlet flange
Noise level	≤ 45 dB (A) at 1 meter
Input	56 Vac, three phase, 633 Hz
Lubricant	permanent lubrication
Storage temperature	- 20° C to + 70° C
Weight kg (lbs)	ISO 200: 19 (41.8) CFF 10": 26 (57.2)

* According to standard DIN 28 428, the base pressure is that measured in a leak-free test dome, 48 hours after the completion of test dome bake-out, and using the recommended pre-vacuum pump.

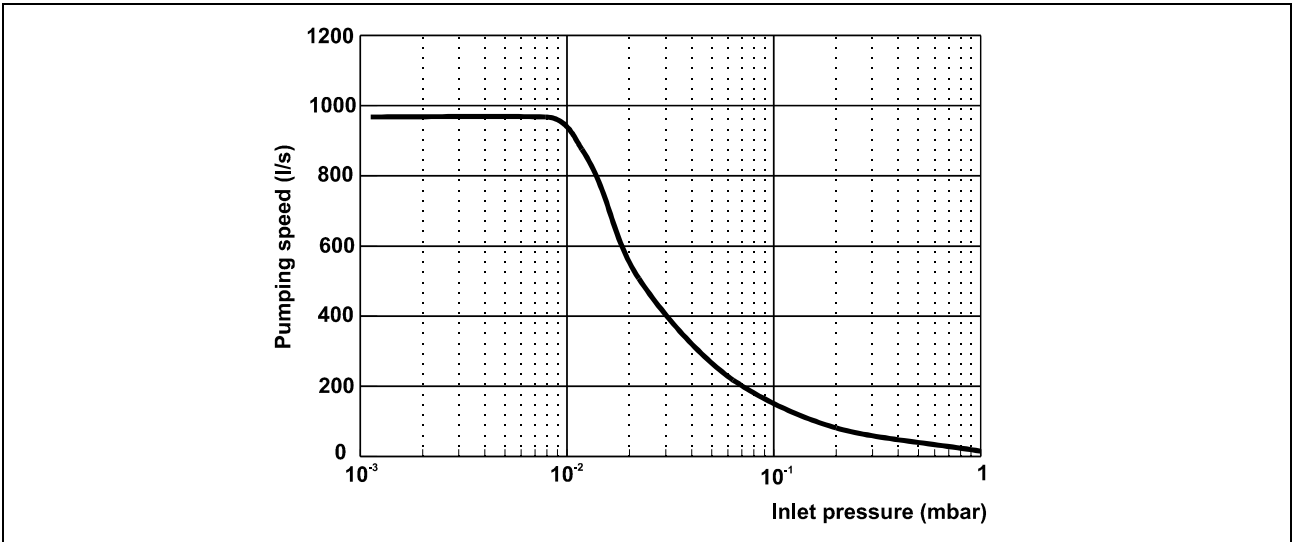

Graph of nitrogen pumping speed vs inlet pressure

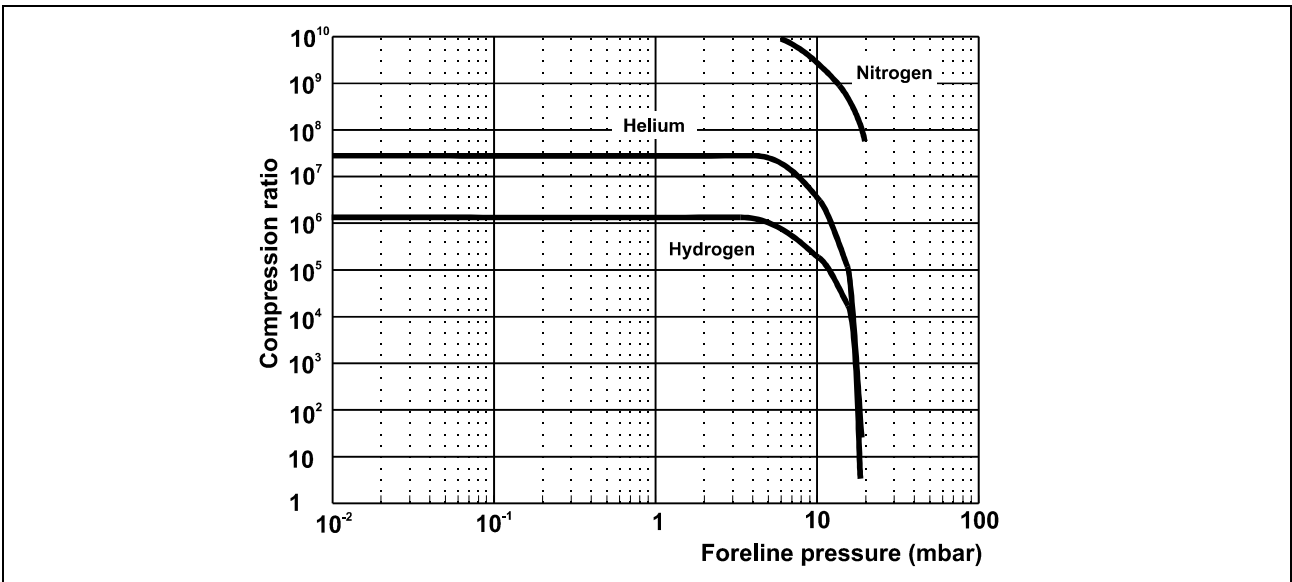

Graph of compression ratio vs foreline pressure

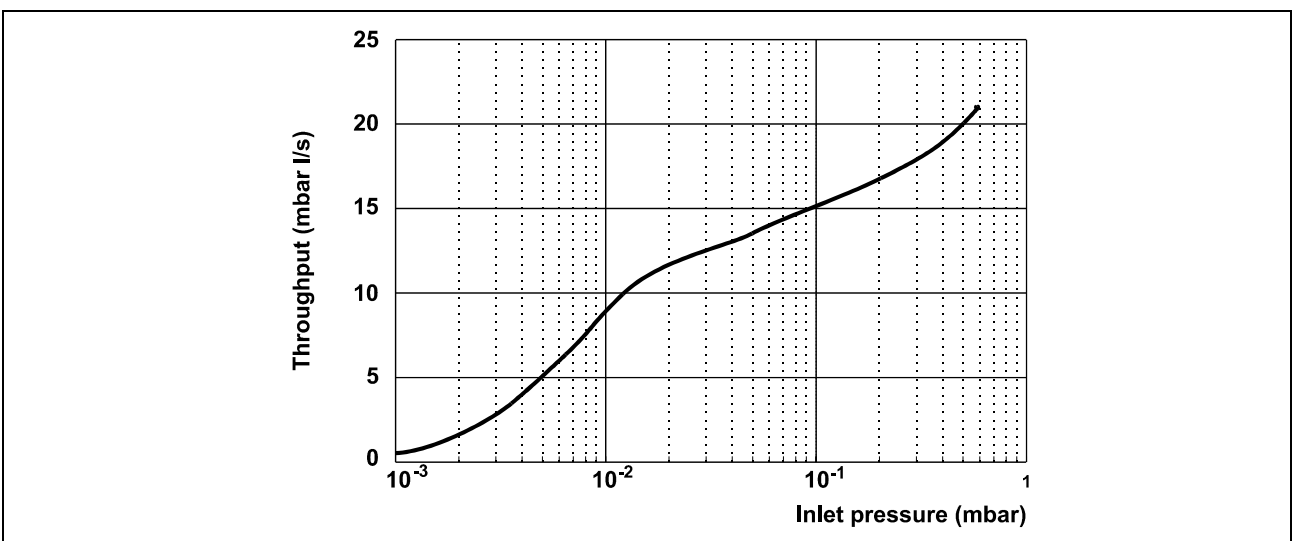

Graph of nitrogen throughput vs inlet pressure using the recommended mechanical forevacuum pump

INLET SCREEN INSTALLATION

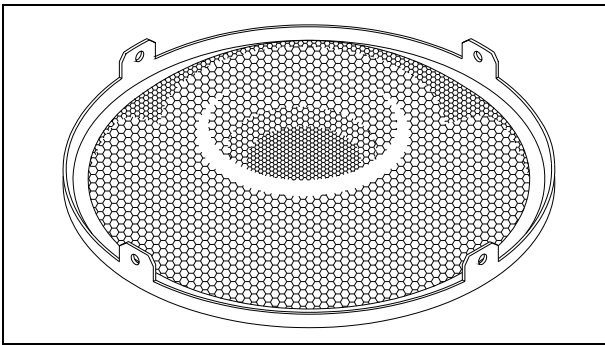

The inlet screens mod. 969-9316 prevents the blades of the pump from being damaged by debris greater than 0.7 mm diameter. The inlet screen, however, will reduce the pumping speed by about 10%. The inlet screen is fitted in the upper part of the pump, as shown in the figure.

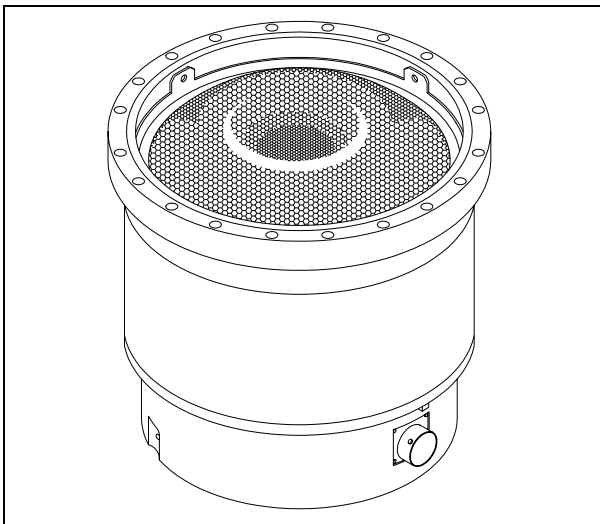

The screen can be mounted on each pump model.

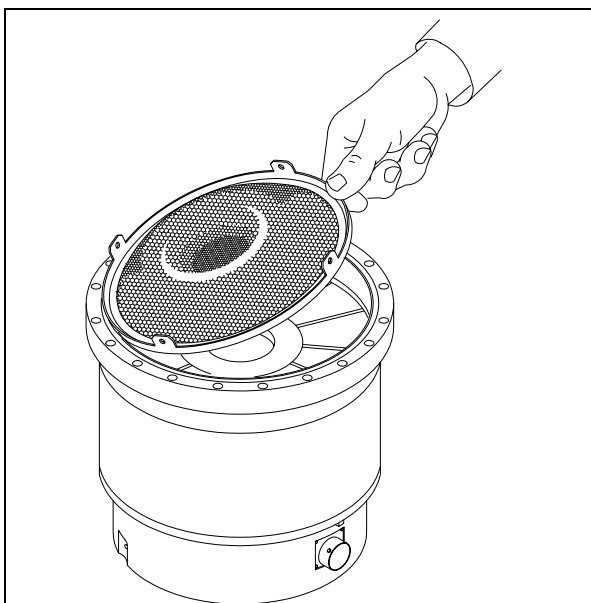

The following figure show the overall flange dimensions with the protection screen fitted on pump with ISO flange and pump with CFF flange.

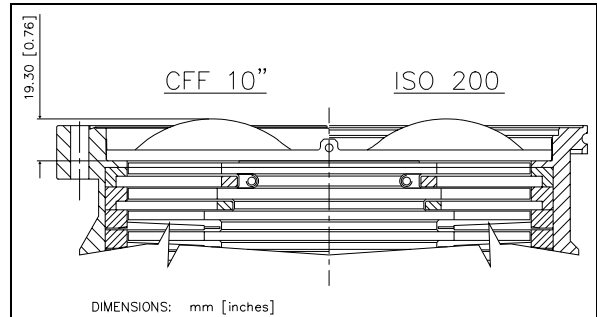

HEATING JACKET INSTALLATION

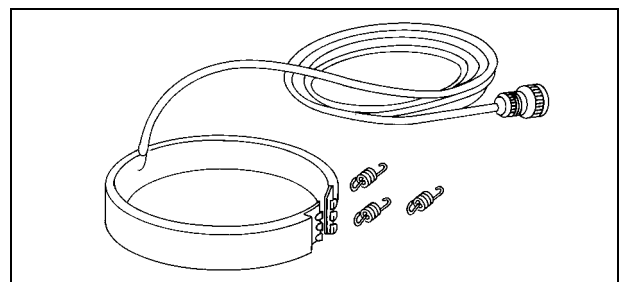

The heating jacket model 969-9819 can be used to heat the pump casing when a condensable process by-products are present. It is applied on the lower part of the pump casing with the provided set of springs, as shown in the figure, to heat the envelope to a temperature between 40° and 90° C under controller selection. The jacket must be mounted in order to have a perfect thermal contact between the heating surface and the pump envelope to obtain a fast and efficient heating.

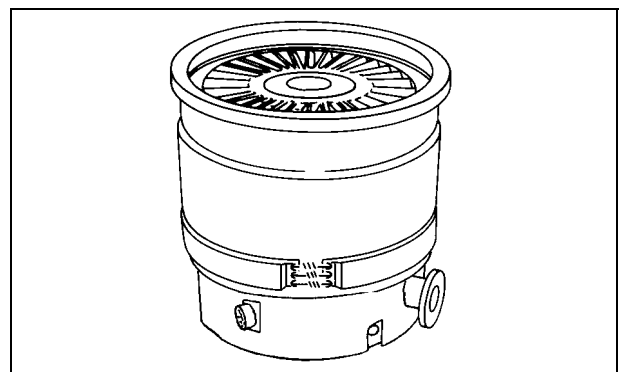

Once the heating jacket is installed and connected, set the controller to operate it at the desired temperature by means of the configuration menu (refer to the controller manual for details). The heating jacket will be started by pressing the pump start button.

A dedicated temperature sensor into the heating jacket will keep the pump temperature at the desired temperature.

NOTE

Please make sure to have a perfect contact between the heating jacket thermistor and the pump envelope for a safe and efficient operation.

CAUTION

If the chamber of the system is "baked" at a high temperature, a shield should be installed to prevent thermal radiation heating the high vacuum flange on the pump. The maximum temperature allowed for the inlet flange is 120° C.

WATER COOLING KIT INSTALLATION

Two types of water cooling kits are available to be mounted when the pump is used under heavy load conditions or when air cooling is insufficient.

The two model part numbers are: 969-9338 (metallic model), and 969-9348 (plastic model).

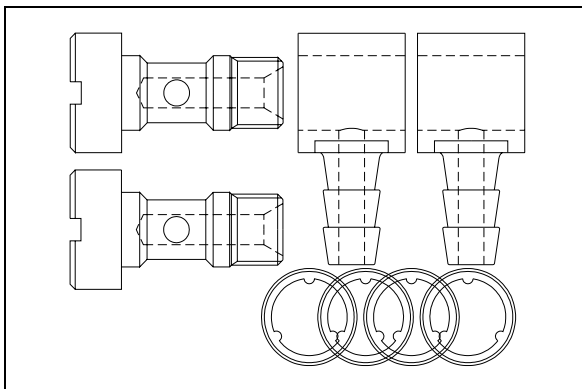

Model 969-9338

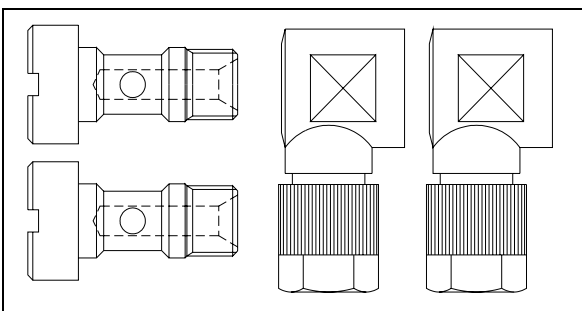

Model 969-9348

CAUTION

The items of the plastic model kit must be assembled as shown in the following figure

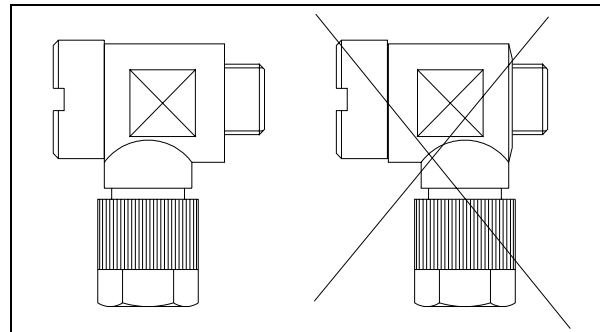

The assembled kit must be screwed into the suitable holes of the pump body with a recommended closing torque of 5 Nm.

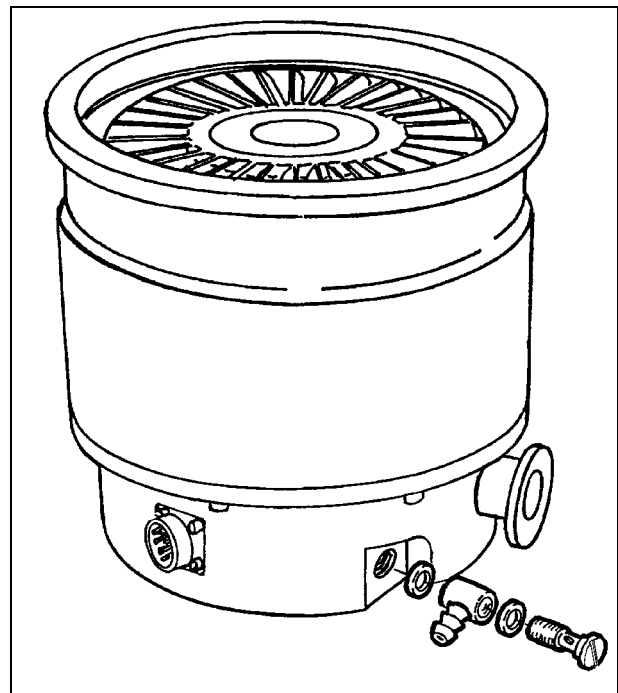

The water cooling kit 969-9338 has to be connected to a 3/8" internal diameter flexible water line.

The water cooling kit 969-9348 has to be connected to a 6x8 (internal diameter x external diameter) metric flexible water line.

Cooling may be carried out either through an open circuit with eventual discharge of the water, or using a closed circuit cooling system.

The water temperature must be between +10°C and +20°C, with an inlet pressure between 3 and 5 bar. This allows a flow of about 200 l/h.

NOTE

The water electrical conductance must be $\leq 500 \mu\text{s/cm}$. When the conductance is higher, in closed water circuit, the use of up to 20% of Ethyl-Glycole is suggested.

VENT DEVICE INSTALLATION

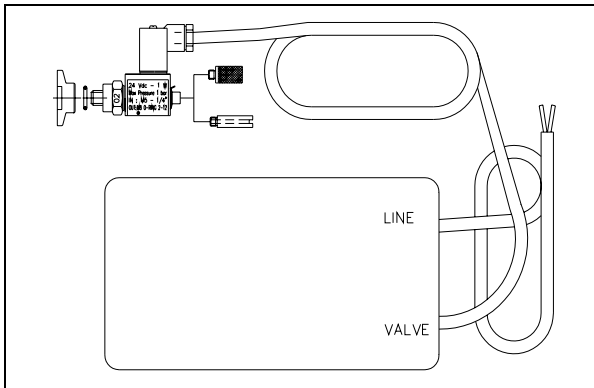

The vent device mod. 969-9831 allows to avoid undesired venting of the pump during a temporary power failure (adjustable time up to 36 min.), and enables an automatic vent operation.

Unscrew and remove the threaded plug (see figure below).

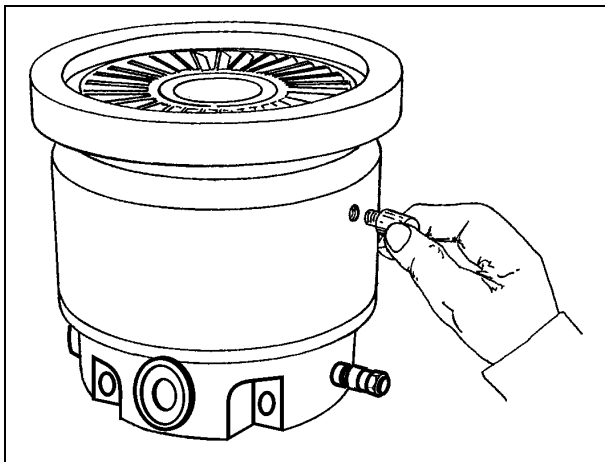

Screw the flange mod. 969-9108 on the pump, taking care of the o-ring right position.

Assemble the seal ring and lock the vent device in position using the KF klamp.

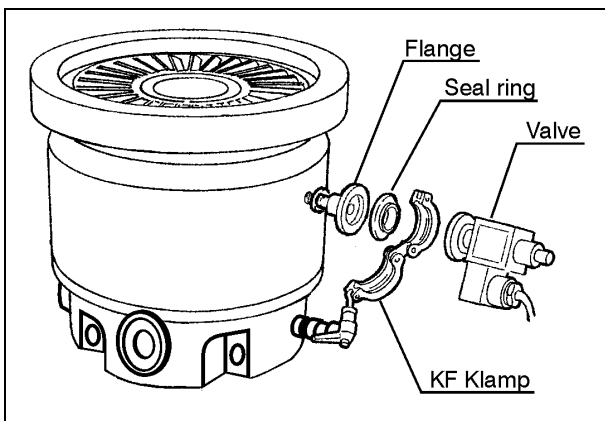

VENT VALVE INSTALLATION

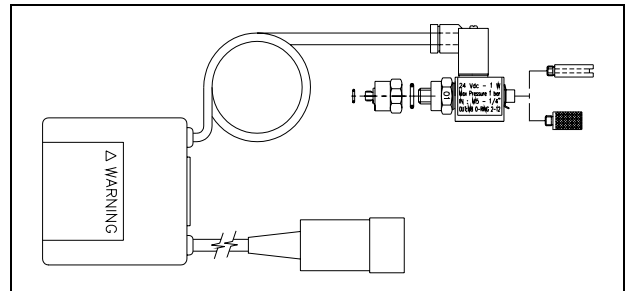

The vent valve mod. 969-9833 allows to avoid undesired venting of the pump during a temporary power failure (5 sec maximum), and enables an automatic vent operation.

Unscrew the threaded plug (see figure below).

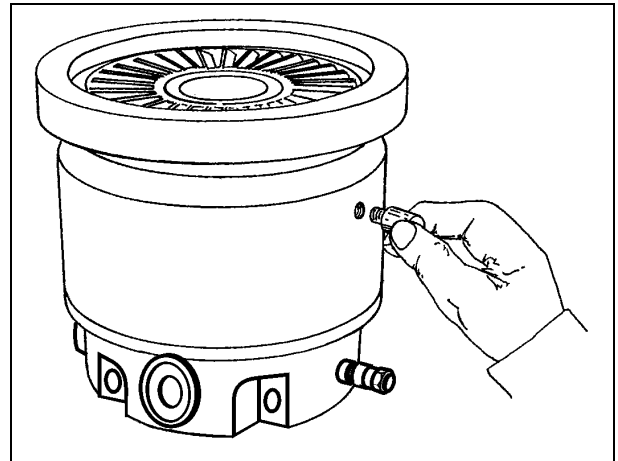

Screw the vent valve into the pump without inserting the supplied adapter between the valve and the pump.

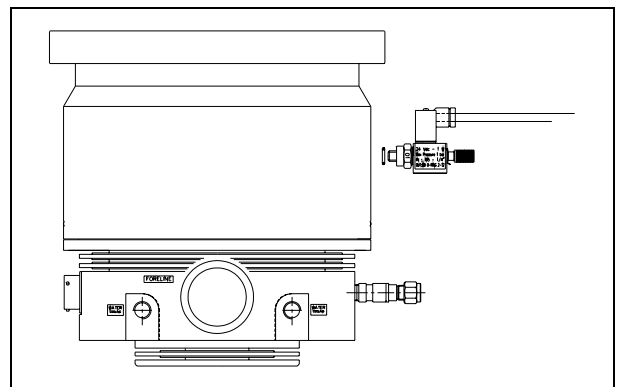

Tighten the valve using a 16 mm. hexagonal spanner with a torque of 2.5 Nm.

⚠ CAUTION

Do not overtighten the valve as this may damage the thread on the pump.

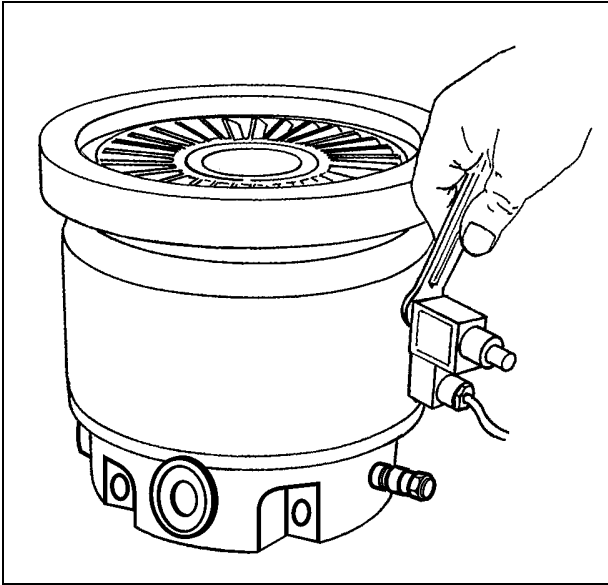

PUMP USED WITH CORROSIVE GASES

To prevent damage to the bearings, an inert gas must flow into the pump body around the upper bearing towards the forevacuum line.

The inert purge gas (e. g. nitrogen, argon) is supplied to the pump through the integrated purge valve. A pressure regulator can be installed between the purge valve and the gas purge source. Adjust the pressure regulator in order to obtain the necessary gas purge flow rate of 20 sccm.

The standard gas purge may be supplied with 1 atm (15 psig) to get 20 sccm.

CAUTION

To prevent bearing damage, the integrated purge valve is foreseen for a gas flow rate of 20 sccm (0.34 mbar l/s). Please contact Varian for specific applications.

SOLID STATE FLOWMETER INSTALLATION

A gas purge valve is integrated to protect the pump bearings against particulate and corrosive gases that could move into the pump.

To the purge valve can be connected a solid state flowmeter model 969-9114 (see the following figure) or model 969-9115, operating in the range from 0 to 150 SCCM with Nitrogen, and from 0 to 125 SCCM with Argon, that connected to the controller can monitor the flow of the protective gas purge.

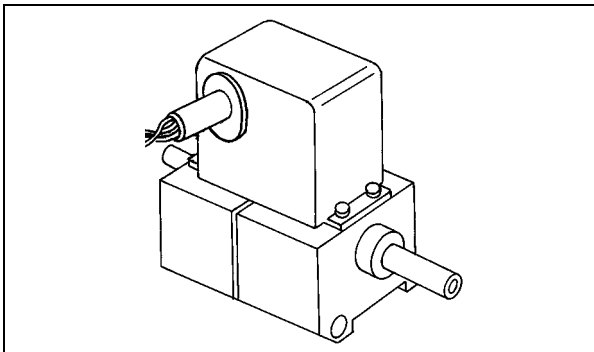

The following figure shows the connector of the flowmeter to the controller.

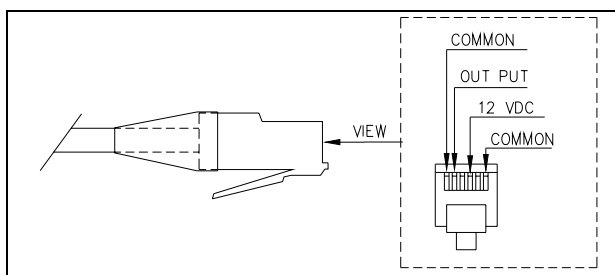

The recommended gas flow maintains a pressure into the pump body higher than the forevacuum pressure.

The recommended procedure to vent the system and the pump avoiding the contact between the pump bearings and the corrosive gas is described in the following points:

1. Close the corrosive gas flow into the system.
2. Leaving the Turbo-V pump and the backing pump running and the purge gas flowing, wait for enough time to evacuate the corrosive gas from the system.
3. Open the Turbo-V vent port slowly until to reach atmospheric pressure in the system.
4. Turn off the Turbopump.
5. When the Turbo-V pump and the backing pump are stopped and the system is at atmospheric pressure, for a better bearing protection it is advisable to leave the purge gas flowing into the Turbo-V pump, with the chamber or the Turbo-V vent valve opened, to avoid system overpressures. If the vent valve can't be kept opened, the backing pump should be left operating.

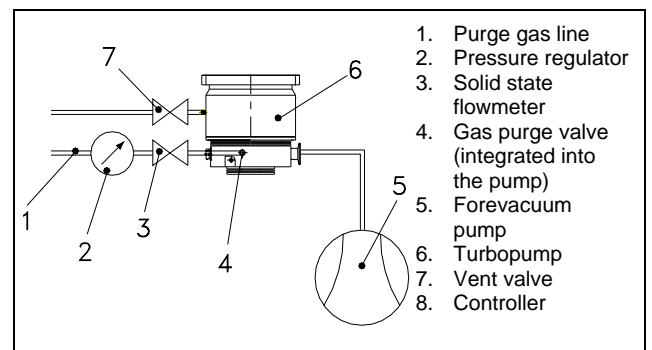

TYPICAL LAYOUT DIAGRAM

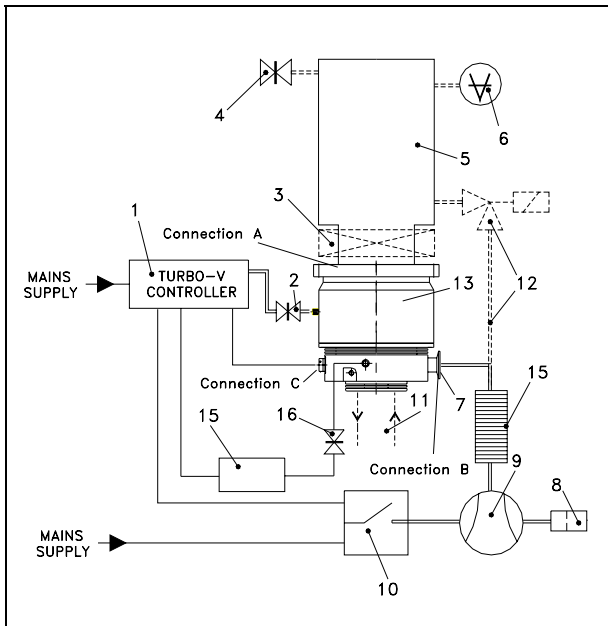

1. Turbo-V controller
2. Vent valve
3. Vacuum pump shut-off valve (optional)
4. System vent valve (optional)
5. Vacuum chamber
6. Ionisation gauge
7. Fore-vacuum pump connecting flange
8. Oil mist eliminator
9. Fore-vacuum pump with internal one-way valve
10. Fore-vacuum pump control relay
11. Connection for water cooling
12. Roughing line with valve (optional)
13. Turbopump
14. Flexible connection
15. Solid state flowmeter
16. Gas purge valve (integrated into the pump)

Connection A - HIGH VACUUM FLANGE

To connect the Turbo pump to the ISO inlet flange, remove the outer ring and position the centering ring as shown in the figure.

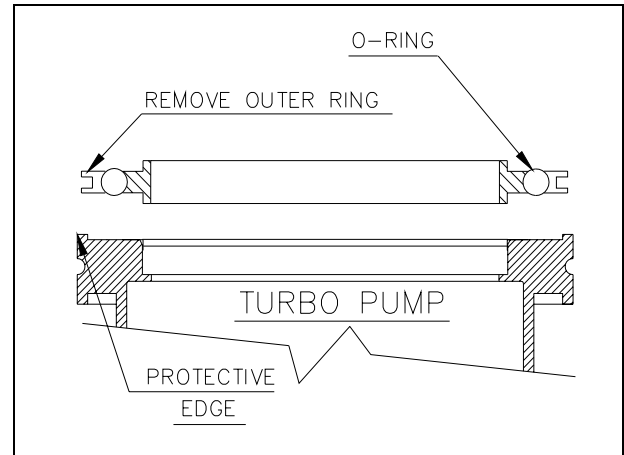

Then fix the two flanges with the clamps or claws as shown in the figure.

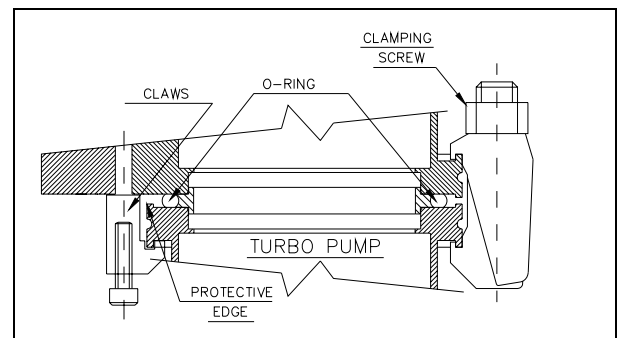

For ConFlat flange connections we recommend using Varian hardware. Other hardware can be used if it satisfies to this specifications:

- stainless steel screws
- minimum strength point of 500 N/mm²
- length: 63.5 mm (2.5 inches).

To facilitate assembly and dismantling, apply Felpro C-100 high temperature lubricant to the screw threads protruding from the flange and between the nuts and flange.

Note that the connections can be made only with the bolt in the lower side.

Attach the units and tighten each one in turn. Repeat the sequential tightening until the flange faces meet.

 CAUTION

Exercise care when tightening nuts and bolts to avoid creating dents in the envelope as this may cause the pump rotor to lock.

Connection configurations

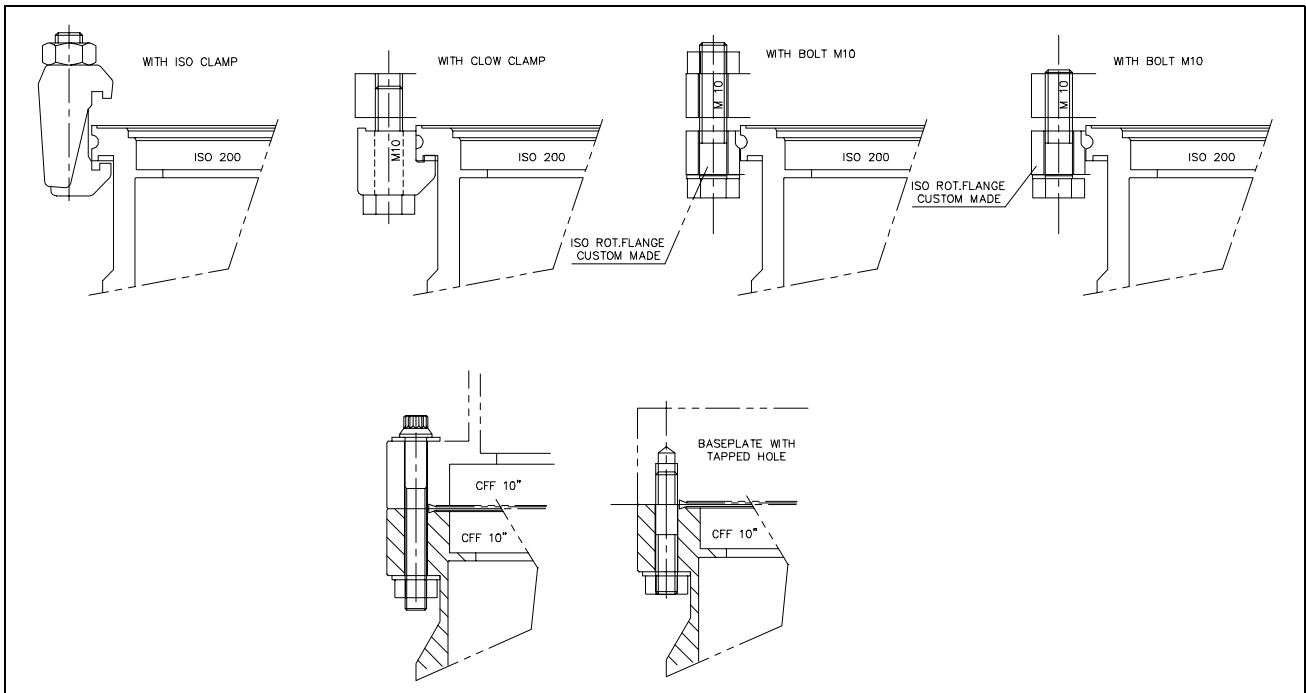

Connection B - FORE-VACUUM PUMP

A flange KF 40 NW is available to connect the Turbopump to the fore-vacuum pump. A hose or vacuum approved pipe can be used. If a rigid pipe is used, any vibration generated by the mechanical pump must be eliminated through the use of bellows.

NOTE

The Turbo pump is characterized by its high compression ratio also for oil vapors. When using a mechanical oil-sealed pump, it is advisable to install a suitable trap between the turbopump and the fore-vacuum pump in order to prevent oil back-streaming.

Connection C - ELECTRICAL

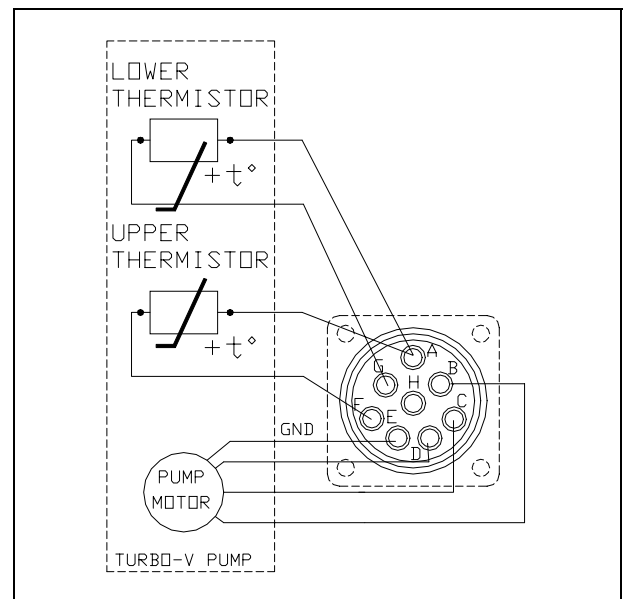

The turbopump is connected to the controller through an 8-pin connector. Pins B, C and D are the 3-phase supply to the motor, pins A, F and G are connected to the temperature sensors (NTC type, 30 KΩ resistance at 20° C) and pin E is connected to the pump ground; pin H is not connected.

If the temperature sensors are disconnected, the pump will not start. To prevent damage to the pump when the temperature exceeds 60° C, the sensors automatically cut out the power supply.

SUGGESTED PUMP INSTALLATION

The following figure shows a suggested pump installation.

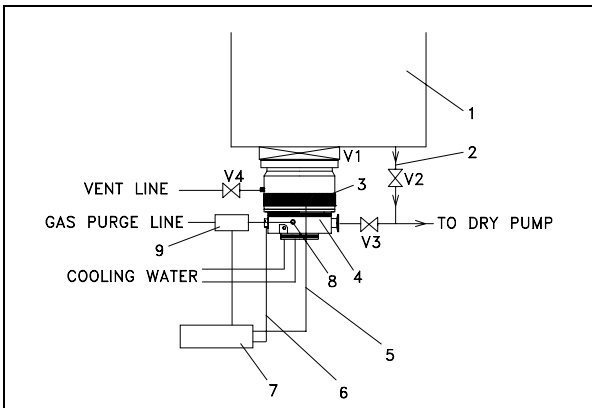

- 1. Vacuum chamber
- 2. Rough line
- 3. Heater jacket
- 4. ICE Turbo pump
- 5. Heater cable
- 6. Pump cable
- 7. Pump controller
- 8. Gas purge valve
- 9. Solid state flowmeter
- V1 Gate valve
- V2 Rough valve
- V3 Dry pump valve
- V4 Vent valve

ROUGHING OPERATION

Roughing of the vacuum chamber should be performed through a separate line and not through the Turbopump.

Typical roughing sequences are detailed in the following paragraphs (see the above figure).

NOTES

Gas Purge must be always on. Even during the pump start-up or shutdown, supply pressure on gas purge valve must be > 1 bar (15 psig).

NOTES

Venting of the pump must be performed in minimum 3 minutes from the pump stop signal. Backing pump should be left on for the first 30" of venting to prevent pressure burst inside the turbopump. A gate valve on the pump inlet is definitely suggested if dust is known to be present in the process chamber.

Solid State Flowmeter must be used and the relative alarm signal on the controller must be interfaced on the system to indicate any low purge flow condition. Proper actions must be taken on the system when a low purge condition is present.

The special heater jacket should be used if condensable materials are known to be present during the process. The heater jacket working temperature should be adjusted on the pump control unit (see controller manual for reference). Ask VARIAN for proper temperature setting. Heater jacket must be always on even during start-up and shutdown.

Filtered cooling water should be used in closed circuitry. Tap water could be used in closed cooling circuitry in addition of 40% of ethyl glycol. The electrical conductance of the water must be < 500 μS/cm. Tap water could be tolerated if its electrical conductance is lower than 500 μS/cm.

Pump and chamber at atmosphere

- 1. V1, V2, and V4 closed; V3 open. Start backing chamber and Turbo at the same time.
- 2. When Turbo at Normal operation close V3, open V2 and rough the chamber up to 10⁻¹ mbar or lower.
- 3. Close V2; open V3.
- 4. Open V1 and Start process.

Pump under vacuum, chamber at atmosphere (chamber cleaning)

- 1. V1, V2 and V4 closed; V3 opened. Turbopump is in Normal operation.
- 2. V3 closed; V2 open.
- 3. Rough down to 10⁻¹ mbar or lower.
- 4. Close V2; open V3.

PUMP USED IN PRESENCE OF MAGNETIC FIELDS

Magnetic fields induce eddy currents in the rotor of a turbomolecular pump that tend to oppose to its rotation. The result is increased electrical power consumption by the motor, most of which is dissipated in the rotor.

Since the rotor is not in contact with the stator the above power can leave the rotor mainly by radiation and hence the rotor may be overheated while static parts of the pump remain cool. This effect is strongly dependant from the intensity, time function and distribution of the magnetic field.

In general, therefore, an increase in pump current can be expected. If this increase is lower than 50% of the current value drawn by the motor in high vacuum operation, no particular problem should be expected.

However if the effect is grater, than the case should be carefully reviewed by Varian's specialist. As a matter of fact, in case of high magnetic fields, also important forces might be generated and applied to the rotor.

ACCESSORIES

DESCRIPTION	PART NUMBER
Inlet screen, ISO 200	969-9316
Heating jacket	969-9819
Water cooling kit for American fractional tubes	969-9338
Water cooling kit for Metric tubes	969-9348
Pump to controller cable	969-9953
Vent flange NW 10 KF (M8)	969-9108
Vent valve with fixed delay time	969-9833
Vent device with adjustable delay time	969-9831
Solid state flowmeter 1/4" Swagelock	969-9114
Solid state flowmeter KF16	969-9115
Forepump DS 402, with 1 ph. / 3 ph., universal motor	949-9382
Triscroll Dry Vacuum Pump PTS 300 single phase, universal motor	PTS03001UNIV
Triscroll Dry Vacuum Pump PTS 300 3 phase, universal motor	PTS03003UNIV
Forepump MD 60, 120 V	949-9411
Forepump MD 60, 220 V	949-9412

For a complete overview of Varian's extensive product lines, please refer to the Varian catalog.



Request for Return



1. A Return Authorization Number (RA#) **WILL NOT** be issued until this Request for Return is completely filled out, signed and returned to Varian Customer Service.
2. Return shipments shall be made in compliance with local and international **Shipping Regulations** (IATA, DOT, UN).
3. The customer is expected to take the following actions to ensure the **Safety** of workers at Varian: (a) Drain any oils or other liquids, (b) Purge or flush all gasses, (c) Wipe off any excess residues in or on the equipment, (d) Package the equipment to prevent shipping damage, (for Advance Exchanges please use packing material from replacement unit).
4. Make sure the shipping documents clearly show the RA# and then return the package to the Varian location nearest you.

North and South America

Varian Vacuum Technologies
 121 Hartwell Ave
 Lexington, MA 02421
 Phone : +1 781 8617200
 Fax: +1 781 8609252

Europe and Middle East

Varian SpA
 Via Flli Varian 54
 10040 Leini (TO) – ITALY
 Phone: +39 011 9979111
 Fax: +39 011 9979330

Asia and ROW

Varian Vacuum Technologies
 Local Office

CUSTOMER INFORMATION

Company name:	
Contact person: Name:	Tel:
Fax:	E-Mail:
Ship Method:	Shipping Collect #: P.O.#:
<i>Europe only:</i> VAT reg. Number:	<i>USA only:</i> <input type="checkbox"/> Taxable <input type="checkbox"/> Non-taxable
Customer Ship To:	Customer Bill To:
.....
.....

PRODUCT IDENTIFICATION

Product Description	Varian P/N	Varian S/N	Purchase Reference

TYPE OF RETURN (check appropriate box)

<input type="checkbox"/> Paid Exchange	<input type="checkbox"/> Paid Repair	<input type="checkbox"/> Warranty Exchange	<input type="checkbox"/> Warranty Repair	<input type="checkbox"/> Loaner Return
<input type="checkbox"/> Credit	<input type="checkbox"/> Shipping Error	<input type="checkbox"/> Evaluation Return	<input type="checkbox"/> Calibration	<input type="checkbox"/> Other

HEALTH and SAFETY CERTIFICATION

Varian Vacuum Technologies **CAN NOT ACCEPT** any equipment which contains **BIOLOGICAL HAZARDS** or **RADIOACTIVITY**. Call Varian Customer Service to discuss alternatives if this requirement presents a problem.

The equipment listed above (check one):

HAS NOT been exposed to any toxic or hazardous materials

OR

HAS been exposed to any toxic or hazardous materials. In case of this selection, check boxes for any materials that equipment was exposed to, check all categories that apply:

Toxic Corrosive Reactive Flammable Explosive Biological Radioactive

List all toxic or hazardous materials. Include product name, chemical name and chemical symbol or formula.

.....

Print Name: Customer Authorized Signature:

Print Title: Date:/...../.....

NOTE: If a product is received at Varian which is contaminated with a toxic or hazardous material that was not disclosed, **the customer will be held responsible** for all costs incurred to ensure the safe handling of the product, and **is liable** for any harm or injury to Varian employees as well as to any third party occurring as a result of exposure to toxic or hazardous materials present in the product.

Do not write below this line

Notification (RA)#: Customer ID#: Equipment #:



Request for Return



FAILURE REPORT

TURBO PUMPS and TURBOCONTROLLERS

<input type="checkbox"/> Does not start <input type="checkbox"/> Does not spin freely <input type="checkbox"/> Does not reach full speed <input type="checkbox"/> Mechanical Contact <input type="checkbox"/> Cooling defective	<input type="checkbox"/> Noise <input type="checkbox"/> Vibrations <input type="checkbox"/> Leak <input type="checkbox"/> Overtemperature	POSITION <input type="checkbox"/> Vertical <input type="checkbox"/> Horizontal <input type="checkbox"/> Upside-down <input type="checkbox"/> Other:
		PARAMETERS Power: Rotational Speed: Current: Inlet Pressure: Temp 1: Foreline Pressure: Temp 2: Purge flow:
TURBOCONTROLLER ERROR MESSAGE:		

ION PUMPS/CONTROLLERS

<input type="checkbox"/> Bad feedthrough <input type="checkbox"/> Vacuum leak <input type="checkbox"/> Error code on display	<input type="checkbox"/> Poor vacuum <input type="checkbox"/> High voltage problem <input type="checkbox"/> Other
Customer application:	

VALVES/COMPONENTS

<input type="checkbox"/> Main seal leak <input type="checkbox"/> Solenoid failure <input type="checkbox"/> Damaged sealing area	<input type="checkbox"/> Bellows leak <input type="checkbox"/> Damaged flange <input type="checkbox"/> Other
Customer application:	

LEAK DETECTORS

<input type="checkbox"/> Cannot calibrate <input type="checkbox"/> Vacuum system unstable <input type="checkbox"/> Failed to start	<input type="checkbox"/> No zero/high background <input type="checkbox"/> Cannot reach test mode <input type="checkbox"/> Other
Customer application:	

INSTRUMENTS

<input type="checkbox"/> Gauge tube not working <input type="checkbox"/> Communication failure <input type="checkbox"/> Error code on display	<input type="checkbox"/> Display problem <input type="checkbox"/> Degas not working <input type="checkbox"/> Other
Customer application:	

PRIMARY PUMPS

<input type="checkbox"/> Pump doesn't start <input type="checkbox"/> Doesn't reach vacuum <input type="checkbox"/> Pump seized	<input type="checkbox"/> Noisy pump (describe) <input type="checkbox"/> Over temperature <input type="checkbox"/> Other
Customer application:	

DIFFUSION PUMPS

<input type="checkbox"/> Heater failure <input type="checkbox"/> Doesn't reach vacuum <input type="checkbox"/> Vacuum leak	<input type="checkbox"/> Electrical problem <input type="checkbox"/> Cooling coil damage <input type="checkbox"/> Other
Customer application:	

FAILURE DESCRIPTION

(Please describe in detail the nature of the malfunction to assist us in performing failure analysis):

NOTA: Su richiesta questo documento è disponibile anche in Tedesco, Italiano e Francese.

REMARQUE : Sur demande ce document est également disponible en allemand, italien et français.

HINWEIS: Auf Anfrage ist diese Unterlage auch auf Deutsch, Italienisch und Französisch erhältlich.

Sales and Service Offices

Argentina

Varian Argentina Ltd.

Sucursal Argentina
Av. Ricardo Balbin 2316
1428 Buenos Aires
Argentina
Tel: (54) 1 783 5306
Fax: (54) 1 786 5172

Australia

Varian Australia Pty Ltd.

679-701 Springvale Road
Mulgrave, Victoria ZZ 3170
Australia
Tel: (61) 395607133
Fax: (61) 395607950

Benelux

Varian Vacuum Technologies

Rijksstraatweg 269 H,
3956 CP Leersum
The Netherlands
Tel: (31) 343 469910
Fax: (31) 343 469961

Brazil

Varian Industria e Comercio Ltda.

Avenida Dr. Cardoso de Mello 1644
Vila Olimpia
Sao Paulo 04548 005
Brazil
Tel: (55) 11 3845 0444
Fax: (55) 11 3845 9350

Canada

Central coordination through:

Varian Vacuum Technologies
121 Hartwell Avenue
Lexington, MA 02421
USA
Tel: (781) 861 7200
Fax: (781) 860 5437
Toll Free: (800) 882 7426

China

Varian Technologies - Beijing

Room 1201, Jinyu Mansion
No. 129A, Xuanwumen Xidajie
Xicheng District
Beijing 1000031 P.R. China
Tel: (86) 10 6608 1530
Fax: (86) 10 6608 1534

France and Wallonie

Varian s.a.

7 avenue des Tropiques
Z.A. de Courtaboeuf – B.P. 12
Les Ulis cedex (Orsay) 91941
France
Tel: (33) 1 69 86 38 13
Fax: (33) 1 69 28 23 08

Germany and Austria

Varian Deutschland GmbH

Alsfelder Strasse 6
Postfach 11 14 35
64289 Darmstadt
Germany
Tel: (49) 6151 703 353
Fax: (49) 6151 703 302

India

Varian India PVT LTD

101-108, 1st Floor
1010 Competent House
7, Nangal Raya Business Centre
New Delhi 110 046
India
Tel: (91) 11 5548444
Fax: (91) 11 5548445

Italy

Varian Vacuum Technologies

Via F.lli Varian, 54
10040 Leini, (Torino)
Italy
Tel: (39) 011 997 9111
Fax: (39) 011 997 9350

Japan

Varian Vacuum Technologies

Sumitomo Shibaura Building, 8th Floor
4-16-36 Shibaura
Minato-ku, Tokyo 108
Japan
Tel: (81) 3 5232 1253
Fax: (81) 3 5232 1263

Korea

Varian Technologies Korea, Ltd.

Shinsa 2nd Bldg. 2F
966-5 Daechi-dong
Kangnam-gu, Seoul
Korea 135-280
Tel: (82) 2 3452 2452
Fax: (82) 2 3452 2451

Mexico

Varian S.A.

Concepcion Beistegui No 109
Col Del Valle
C.P. 03100
Mexico, D.F.
Tel: (52) 5 523 9465
Fax: (52) 5 523 9472

Taiwan

Varian Technologies Asia Ltd.

18F-13 No.79, Hsin Tai Wu Road
Sec. 1, Hsi Chih
Taipei Hsien
Taiwan, R.O.C.
Tel: (886) 2 2698 9555
Fax: (886) 2 2698 9678

UK and Ireland

Varian Ltd.

28 Manor Road
Walton-On-Thames
Surrey KT 12 2QF
England
Tel: (44) 1932 89 8000
Fax: (44) 1932 22 8769

United States

Varian Vacuum Technologies

121 Hartwell Avenue
Lexington, MA 02421
USA
Tel: (781) 861 7200
Fax: (781) 860 5437
Toll Free: (800) 882 7426

Other Countries

Varian Vacuum Technologies

Via F.lli Varian, 54
10040 Leini, (Torino)
Italy
Tel: (39) 011 997 9111
Fax: (39) 011 997 9350

Internet Users:

Customer Service & Technical Support:

vtt.customer.service@varianinc.com

Worldwide Web Site:

www.varianinc.com/vacuum

Order On-line:

www.evarian.com

Representatives in most countries

