

**SERIES 350**

**IONIZATION GAUGE**

**CONTROLLER**



**INSTRUCTION MANUAL**

**GRANVILLE-PHILLIPS**  
HELIX TECHNOLOGY CORPORATION

## Service Guidelines and FCC Verification

When returning equipment to Granville-Phillips, please use the original packing material whenever possible. Otherwise, contact your shipper or Granville-Phillips for safe packaging guidelines. Circuit boards and modules separated from the controller chassis must be handled using proper anti-static protection methods and must be packaged in anti-static packaging. Granville-Phillips will supply return packaging materials at no charge upon request.

### FCC Verification

NOTE: This equipment has been tested and found to comply with the limits for a Class B digital device, pursuant to Part 15 of the FCC Rules. These limits are designed to provide reasonable protection against harmful interference when the equipment is operated in a commercial environment. This equipment generates, uses, and can radiate radio frequency energy and, if not installed and used in accordance with this instruction manual, may cause harmful interference to radio communications. However, there is no guarantee that interference will not occur in a particular installation. Operation of this equipment in a residential area is likely to cause harmful interference in which case the user will be required to correct the interference at his own expense. If this equipment does cause harmful interference to radio or television reception, which can be determined by turning the equipment off and on, the user is encouraged to try to correct the interference by one or more of the following measures:

- Reorient or relocate the receiving antenna.
- Increase the separation between the equipment and the receiver.
- Connect the equipment into an outlet on a circuit different from that to which the receiver is connected.
- Consult the dealer or an experienced radio or television technician for help.

### CANADIAN USERS:

This Class B digital apparatus meets all requirements of the Canadian Interference-Causing Equipment Regulations.

Cet appareil numérique de la classe B respecte toutes les exigences du Règlement sur le matériel brouilleur du Canada.

**350 ION GAUGE CONTROLLER**  
**INSTRUCTION MANUAL**

READ AND UNDERSTAND THE CONTENTS OF THIS MANUAL BEFORE ATTEMPTING TO INSTALL OR USE YOUR SERIES 350 ION GAUGE CONTROLLER.

This manual is for use only with catalog numbers 350001, 350002 and 350003. In addition, with specific addendums or other Instruction Manuals for the following custom and catalog numbers this manual is for use with:

350021	20350-338	20350039
350027	20350-339	20350041
350031	20350-346	20350042
	20350-451	20350043
	20350-529	20350044
	20350-544A	20350047
	20350028	20350052
	20350038	

For assistance in using or servicing this instrument contact:

GRANVILLE-PHILLIPS CUSTOMER SERVICE DEPARTMENT  
5675 ARAPAHOE AVENUE  
BOULDER, COLORADO 80303 U.S.A.

TELEPHONE (303) 443-7660, 800-776-6543  
FAX (303) 443-2546

SEE WARNINGS ON PAGES 0-3, 0-4, 0-5, 1-3, 1-8, 1-12, 2-2, 3-1, 5-6

Manual, Catalog No. 350010 101  
Copyright Granville-Phillips, June 1991  
Revised October 1999

## SEE WARNINGS ON NEXT 3 PAGES

### RECEIVING INSPECTION

On receipt of your equipment, inspect all material for damage. Confirm that the shipment includes all items ordered. If items are missing or damaged, submit a claim as stated below for a domestic or international shipment, whichever is applicable.

If materials are missing or damaged, the carrier that made the delivery must be notified within 15 days of delivery, or in accordance with Interstate Commerce regulations for the filing of a claim. Any damaged material, including all containers and packaging, should be held for carrier inspection. Contact our Customer Service Department, 5675 Arapahoe Ave., Boulder, Colorado 80303, telephone (303) 443-7660 or 800-776-6543, if your shipment is not correct for reasons other than shipping damage.

### INTERNATIONAL SHIPMENT

Inspect all materials received for shipping damage and confirm that the shipment includes all items ordered. If items are missing or damaged, the airfreight forwarder or airline making delivery to the customs broker must be notified within 15 days of delivery. The following illustrates to whom the claim is to be directed.

If an airfreight forwarder handles the shipment and their agent delivers the shipment to customs, the claim must be filed with the airfreight forwarder.

If an airfreight forwarder delivers the shipment to a specific airline and the airline delivers the shipment to customs, the claim must be filed with the airline.

Any damaged material, including all containers and packaging, should be held for carrier inspection. If your shipment is not correct for reasons other than shipping damage, contact our Customer Service Department, 5675 Arapahoe Avenue, Boulder, Colorado 80303, U.S.A., telephone (303)443-7660 or 800-776-6543.

### LIMITED WARRANTY



This Granville-Phillips product is warranted against defects in materials and workmanship for 1 year from the date of shipment provided the installation, operating and preventive maintenance procedures specified in this instruction manual have been followed. Granville-Phillips will, at its option, repair, replace or refund the selling price of the product if GP determines, in good faith, that it is defective in materials or workmanship during the warranty period, provided the item is returned to Granville-Phillips together with a written statement of the problem.

Defects resulting from or repairs necessitated by misuse or alteration of the product or any cause other than defective materials or workmanship are not covered by this warranty. GP EXPRESSLY DISCLAIMS ANY OTHER WARRANTY, WHETHER EXPRESSED OR IMPLIED, INCLUDING BUT NOT LIMITED TO THE IMPLIED WARRANTIES OF MERCHANTABILITY AND FITNESS FOR A PARTICULAR PURPOSE. UNDER NO CIRCUMSTANCES SHALL GRANVILLE-PHILLIPS BE LIABLE FOR CONSEQUENTIAL OR OTHER DAMAGES RESULTING FROM A BREACH OF THIS LIMITED WARRANTY OR OTHERWISE.

### WARNING

READ THIS INSTRUCTION MANUAL BEFORE INSTALLING, USING, OR SERVICING THIS EQUIPMENT. IF YOU HAVE ANY DOUBTS ABOUT HOW TO USE THIS EQUIPMENT SAFELY, CONTACT THE GRANVILLE-PHILLIPS CUSTOMER SERVICE DEPARTMENT AT THE ADDRESS LISTED IN THIS MANUAL.

### NOTICE

The  symbol on the rear panel of the controller refers to all of the warnings with the  in this manual.

### DANGER, HIGH VOLTAGE

180 Vdc IS PRESENT IN THE CONTROLLER, ON THE CABLE AND AT THE ION GAUGE TUBE WHEN THE TUBE IS TURNED ON. VOLTAGES AS HIGH AS 530 Vdc ARE PRESENT DURING DEGAS.

### EXPLOSIVE GASES

Do not use Series 350 instruments to measure the pressure of explosive or combustible gases or gas mixtures. Ionization gauge filaments operate at high temperatures.

### IMPLOSION AND EXPLOSION

Glass ionization gauges, if roughly handled, may implode under vacuum causing flying glass which may injure personnel. If pressurized above atmospheric pressure, glass tubes may explode. A substantial shield should be placed around vacuum glassware to prevent injury to personnel.

Danger of injury to personnel and damage to equipment exists on all vacuum systems that incorporate gas sources or involve processes capable of pressuring the system above the limits it can safely withstand.

For example, danger of explosion in a vacuum system exists during backfilling from pressurized gas cylinders because many vacuum devices such as ionization gauge tubes, glass windows, glass belljars, etc., are not designed to be pressurized.

Install suitable devices that will limit the pressure from external gas sources to the level that the vacuum system can safely withstand. In addition, install suitable pressure relief valves or

rupture disks that will release pressure at a level considerably below that pressure which the system can safely withstand.

Suppliers of pressure relief valves and pressure relief disks are listed in Thomas Register under "Valves, Relief", and "Discs, Rupture".

Confirm that these safety devices are properly installed before installing the 350 Ion Gauge Controller (IGC). In addition, check that (1) the proper gas cylinders are installed, (2) gas cylinder valve positions are correct on manual systems, and (3) the automation is correct on automated systems.

**WARNING** ⚠

Operation of the 350 IGC with line voltage other than that selected by the power supply line voltage selector can cause damage to the instrument and injury to personnel.

**WARNING** ⚠

It is the installer's responsibility to ensure that the automatic signals provided by the process control module are always used in a safe manner.

Carefully check manual operation of the system and the setpoint programming before switching to automatic operation. Where an equipment malfunction could cause a hazardous situation, always provide for fail-safe operation. As an example, in an automatic backfill operation where a malfunction might cause high internal pressures, provide an appropriate pressure relief device.

**WARNING** ⚠

Do not attach cables to glass gauge pins while the gauge is under vacuum. Accidental bending of the pins may cause the glass to break and implode. Cables, once installed, should be secured to the system to provide strain relief for the gauge tube pins.

**WARNING** ⚠

Safe operation of vacuum equipment, including the 350 IGC, requires grounding of all exposed conductors of the gauges and the controller and the vacuum system. **LETHAL VOLTAGES** may be established under some operating conditions unless correct grounding is provided.

Research at Granville-Phillips has established that ion producing equipment, such as ionization gauges, mass spectrometers, sputtering systems, etc., from many manufacturers may, under some conditions, provide sufficient electrical conduction via a plasma to couple a high voltage electrode potential to the vacuum chamber. If exposed conductive parts of the gauge, controller, and chamber are not grounded, they may attain a potential near that of the high voltage electrode during this coupling. Potential fatal electrical

shock could then occur because of the high voltage between these exposed conductors and ground.

During routine pressure measurement, using ionization gauge controllers from any manufacturer, about 160 V may become present on ungrounded conductors at pressures near  $10^{-3}$  Torr. All isolated or insulated conductive parts of the controller, the gauge, and the vacuum system must be grounded to prevent these voltages from occurring.

Grounding, though simple, is very important! Please be certain that the ground circuits are correctly utilized on your ion gauge power supplies, gauges, and vacuum chambers, regardless of their manufacturer, for this phenomenon is not peculiar to Granville-Phillips equipment. Refer to Safety Instructions and Section 1.2, Installation, for additional information. If you have questions, or wish additional labels or literature, please contact one of our technical personnel.

**WARNING** 

Do not disconnect the ionization gauge cable from either the gauge tube or controller when the ion gauge is on. The connectors are not rated to break the currents and voltages delivered to the ion gauge.

## TABLE OF CONTENTS

### CHAPTER 1 - THE 350 IGC

#### 1.1 INTRODUCTION

General Description  
Available Options

#### 1.2 INSTALLATION

Line Voltage Selection  
Mounting Configurations  
Ionization Gauge Types and Installation  
System Ground Test Procedure

#### 1.3 OPERATION

Units of Measure  
Power On/Off  
Ion Gauge On/Off  
Degas On/Off  
Remote Input/Output

#### 1.4 THEORY OF OPERATION

Ion Gauge Theory  
Microcontrollers and Bus Structure

#### 1.5 SPECIFICATIONS

### CHAPTER 2 - THE ION GAUGE ELECTROMETER MODULE

#### 2.1 INTRODUCTION

#### 2.2 INSTALLATION

Units of Measure  
Display Update Rate Switch

#### 2.3 OPERATION

Displaying Sensitivity and Emission with  
the Calibration Switch  
Emission Range Switch  
Emission Adjustment  
Sensitivity Adjustment  
Relative Gas Sensitivities  
Analog Output

#### 2.4 ELECTROMETER CALIBRATION



## CHAPTER 3 - THE PROCESS CONTROL MODULE

### 3.1 INTRODUCTION

### 3.2 INSTALLATION

Process Control System Connections

### 3.3 OPERATION

Setpoint Display and Adjustment  
Points to Consider in Using the Process  
Control Module  
Relay Polarity Setting  
Ion Gauge Assignment  
Manual Override

### 3.4 THEORY OF OPERATION

### 3.5 SPECIFICATIONS

## CHAPTER 4 - THE RS-232 MODULE

### 4.1 INTRODUCTION

### 4.2 INSTALLATION

Selecting the Byte Format  
Baud Rate  
Character Framing  
Talk Only Mode

### 4.3 OPERATION

Command Syntax

### 4.4 THEORY OF OPERATION

### 4.5 TROUBLESHOOTING

### 4.6 SPECIFICATIONS

## CHAPTER 5 - THE CONVECTRON GAUGE MODULE

### 5.1 INTRODUCTION

### 5.2 INSTALLATION

Unit of Measure  
Display Update Rate Switch  
Convectron Gauge Tube Installation  
Important Precautions for Gauge Tube Installation  
Gauge Tube Orientation  
Compression Mount (Quick Connect)  
1/8 NPT Mount

NW10, 16 25 and 40KF Flange Mount

5.3 OPERATION

Use With Gases Other Than  $N_2$  and Air  
Indicated vs. True Pressure Curves  
Analog Output

5.4 CALIBRATION

Analog Output Full Scale Adjustment  
Analog Output Offset; Gauges A and B  
Zero Adjustment  
Atmosphere Adjustment

**APPENDIX A      350 CABLE DIAGRAMS**

## CHAPTER 1 - THE 350 IGC

### 1.1 INTRODUCTION

#### General Description

The 350 Ion Gauge Controller (IGC) measures pressures from less than  $1 \times 10^{-11}$  Torr ( $1.3 \times 10^{-11}$  mbar or  $1.3 \times 10^{-9}$  Pa) to  $1 \times 10^{-3}$  Torr, air equivalent, depending on transducer and emission current used. It is primarily intended for use with a nude version of a Bayard-Alpert ionization gauge. Electron bombardment degas is standard with an interlock which only allows usage when displayed pressure is below  $5 \times 10^{-5}$  Torr. A built-in timer turns off the degas function after 15 minutes of operation if not previously done manually. Degas power is fixed at approximately 40 watts.

Two filament switching is standard which allows front panel control of a dual filament style B-A gauge.

Pressure readout is via a front panel digital display and analog output.

Remote I/O provides an IG status output, remote gauge on/off for each filament and remote degas on/off functions.

The 350 IGC is a modular instrument with infrequently used controls housed behind a hinged front panel, thus reducing front panel clutter and allowing the IGC to reside in a half-rack space.

#### Maintenance and Troubleshooting

There are no internal user serviceable parts or adjustments required to assure continued operation of the 350 Vacuum Gauge Controller. Specific sections of this manual contain information required to maintain this product should a field failure occur. The information contained herein is intended to be used only by qualified Service Technicians familiar with the safety concerns and procedures for equipment having circuitry operating at lethal potentials. This equipment has circuitry capable of generating voltages of up to  $600 V_{rms}$ . Consult the factory if you are unsure as to what procedures to follow to ensure personnel safety.

#### Available Options

##### Two Channel Process Control Module (see note)

Provides 2 single pole, double throw relays. Digital setpoints have front panel LED indicators and manual override switches.

##### RS-232 Computer Interface Module (see note)

Provides readout of pressure, process control relay status, and ion gauge control.

**NOTE:** Only one of these two options can be selected in standard

catalog number configurations. Various custom configurations are available where more than one option module may be installed. If the Convector option is used with the Series 350 only Series 275 convector gauge tubes manufactured in June of 1997 or later can be used on the units bearing the CE mark. Each gauge tube is marked with a date code. This date code must be F7 (June 1997) or after.

IG Cables

The IGC is capable of operating an ion gauge located up to 100 feet away from the controller by using standard cables. Cables are available for use with nude B-A gauges using individual slip-on pin connectors for the two filaments, filament common, grid and collector.

Mounting Options

The IGC can be ordered with a variety of mounting options to fit your needs. This includes half rack (standard), bench, full rack, or two units in a full rack.

**1.2 INSTALLATION**

Line Voltage Selection

The 350 VGC is supplied with a convenient IEC 320 AC mains connection receptacle which allows selection of a detachable line cord to match your available AC mains power.

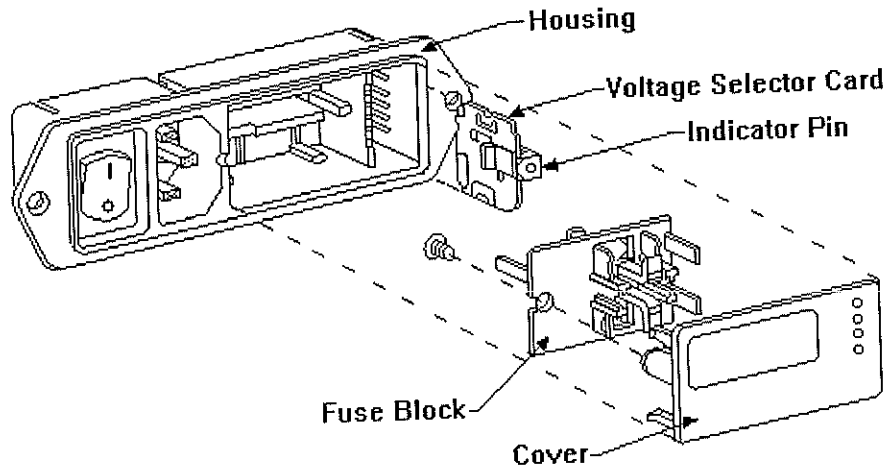

Nominal Line Voltage $\pm 10\%$	Selector Card Setting	Fuse F2 Type	
100 Vac	100	1.25A SB Time Lag (T)	} Note 1
120 Vac	120	1.25A SB Time Lag (T)	
220 Vac	220	.60A SB Time Lag (T)	} Note 2
240 Vac	240	.60A SB Time Lag (T)	

Fig. 1.1 Line Voltage Selector Setting

Note 1 Fuse is Littelfuse 3131.25 (GP P/N 004966).  
Note 2 Fuse is Littelfuse 313.600 (GP P/N 009645); for European fusing, fuses are Littelfuse 218.630 (GP P/N 011681).  
Replacement fuses are available from:  
Granville-Phillips  
5675 Arapahoe Avenue  
Boulder, Colorado 80303 U.S.A.  
1-(800) 776-6543  
email: marketmg@granville.com

Verify that the line voltage selector indicator displays the line voltage value of the available local AC line voltage. If the indicator does not display the correct line voltage value as shown in Fig. 1.1, perform the following procedure (refer to Fig. 1.2).

**WARNING** ⚠

Operation of the IGC with the line voltage selector card improperly set can cause damage to the IGC and injury to personnel.

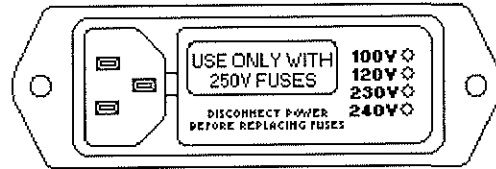

Fig. 1.2 Line Voltage Selector Feature

---

# User Instructions

---

## Fuse Changing

### European Fusing Arrangement

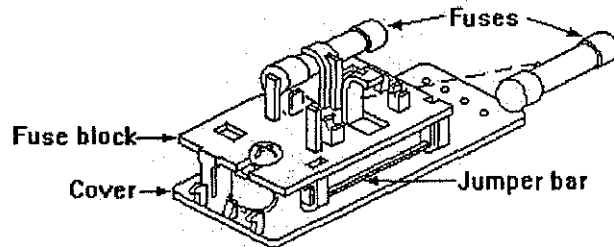

### North American Fusing Arrangement

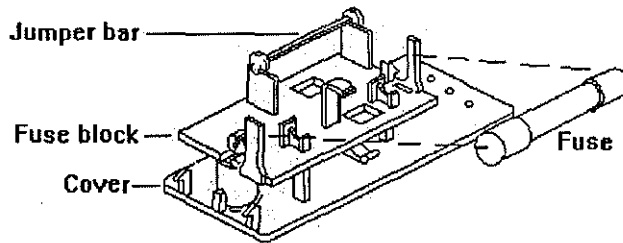

---

## Fuse Block/Cover Assembly

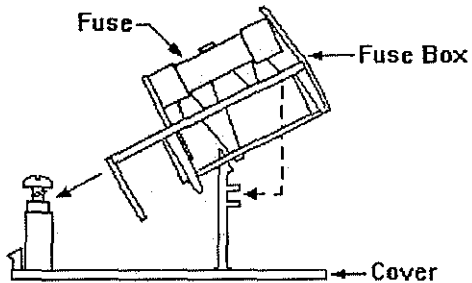

To change from North American to European fusing: open cover, using

small blade screwdriver or similar tool; loosen Phillips screw 2 turns; remove fuse block by sliding up, then away from Phillips screw and lifting up from pedestal; change fuses (note that two European fuses are required, although a dummy fuse may be used in the neutral [lower] holder); invert fuse block and slide back onto Phillips screw and pedestal; tighten Phillips screw, and replace cover (note that fuse(s) that go into the housing first are the active set).

---

### Voltage Selection

To change selected voltage: open cover, using small blade screwdriver or similar tool; set aside cover/fuse block assembly; pull voltage selector card straight out of housing, using indicator pin; orient selector card so that desired voltage is readable at the bottom; orient indicator pin to point up when desired voltage is readable at bottom (note that when indicator pin is fixed, successive voltages are selected by rotating the card 90 degrees clockwise); insert voltage selector card into housing, *printed side of card facing toward IEC connector*, and edge containing the desired voltage first; replace cover, and verify that indicator pin shows the desired voltage.

### Voltage Selector Card Orientation

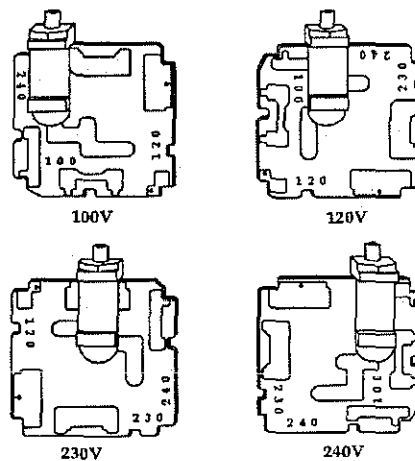

### Mounting Configurations

Fig. 1.3 illustrates the various configurations available for mounting the 350 IGC.

Note that the 350 controller should be mounted in a location with free air flow and ambient temperature less than 40 °C.

### EMC Compliance

In order to comply with the standards for immunity as called for by the EMC Directive, careful consideration to grounding and shielding of instrumentation cables is required. User supplied cables must have the drain shield of the cable connected to chassis ground. Immunity to radiated and conducted RF energy in industrial environments will depend on cable construction and routing. The VGC system will perform within the typical uncertainty of a Bayard-Alpert ion gauge system when subjected to industrial levels of RF energy.

Snap-on ferrite sleeves (GPC P/N 013746, 2 ea. provided) must be installed on the ion gauge cable at both the gauge tube end and controller end of the cable. Failure to install these ferrite suppression cores may result in non-compliance with the EU EMC Standards for Industrial Level Immunity.



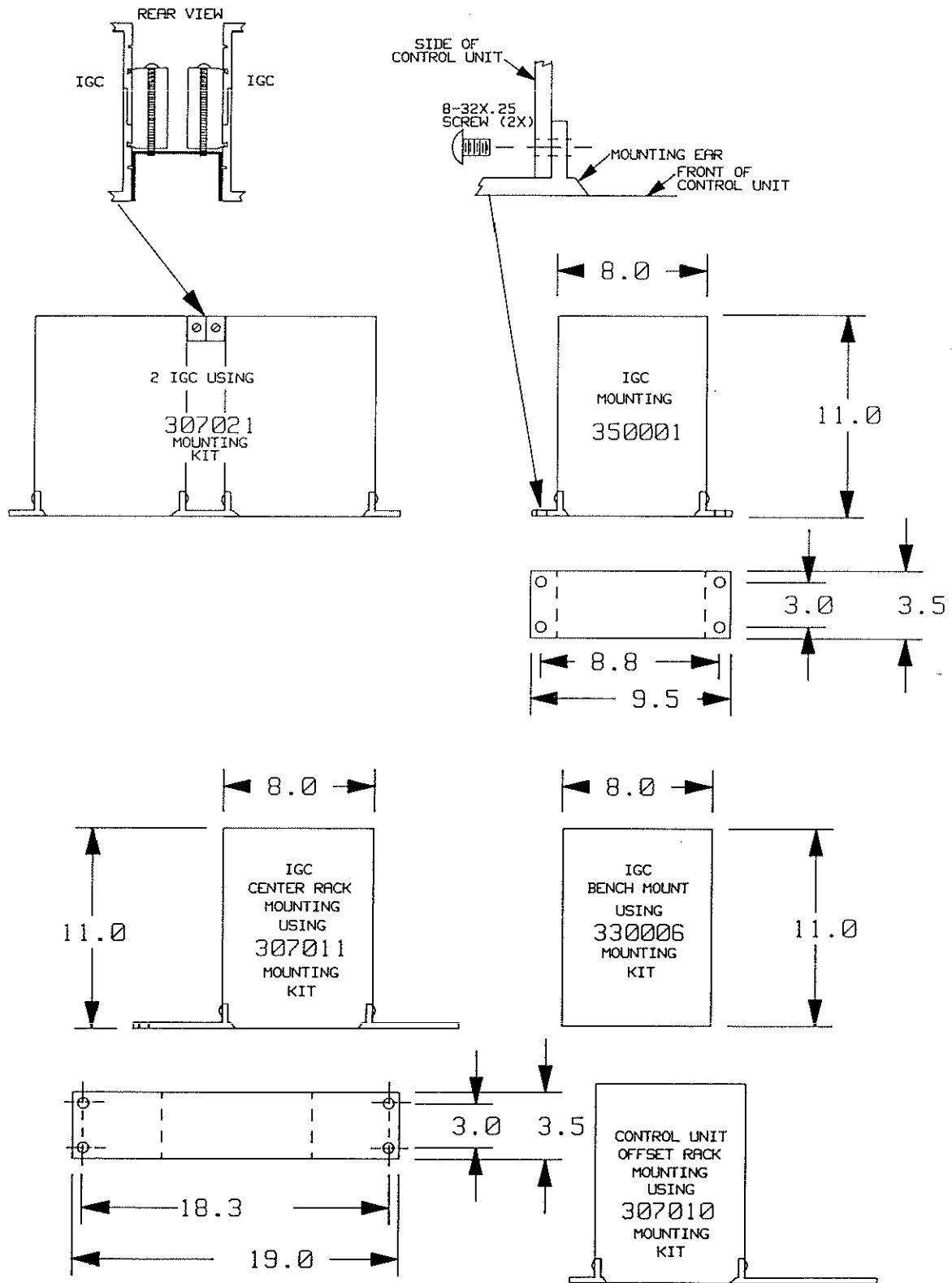

Fig. 1.3 350 Mounting Configurations

## Ionization Gauge Types and Installation

### WARNING

Do not attach cables to glass gauge pins while the gauge is under vacuum. Accidental bending of the pins may cause the glass to break and implode. Cables, once installed, should be secured to the system to provide strain relief for gauge tube pins.

### WARNING

Ionization gauges are safe for use only if all exposed conductors on the gauge and on controller and on vacuum system are grounded.

The 350 IGC is designed to operate a Bayard-Alpert type or equivalent ionization gauge with either single or dual filaments and nude style construction. It is ideally suited for a nude gauge such as the Granville-Phillips 274022 or 274023 which have an x-ray limit in the low  $10^{-11}$  Torr range. When installing your ion gauge, note that if placed near the pump, the pressure in the gauge may be considerably lower than in the rest of the system. If placed near a gas inlet or source of contamination, the pressure in the gauge may be higher.

If an unshielded gauge is placed near an electron beam evaporation source or used in a sputtering system, spurious electrons or ions may disturb the measurement. Screens or other shielding should be placed between the gauge and the system if spurious charged particles or severe electromagnetic interference is present.

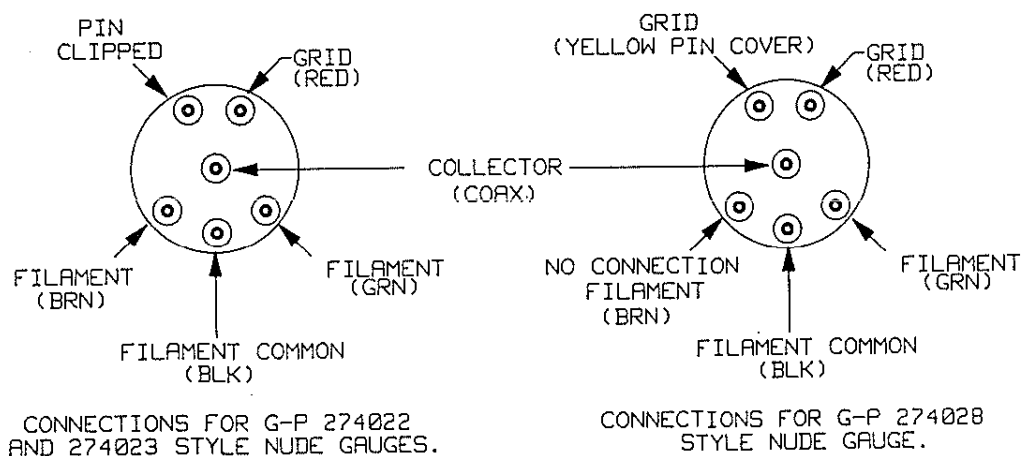

NOTE: FRONT PANEL SWITCH 1 CONTROLS GREEN FILAMENT LEAD AND 2 CONTROLS BROWN FILAMENT LEAD.

Fig. 1.4 Standard Nude Gauge Base Configuration

Fig. 1.4 shows typical nude gauge base configurations used with the standard connector cable.

IONIZATION GAUGE CABLE INSTALLATIONS

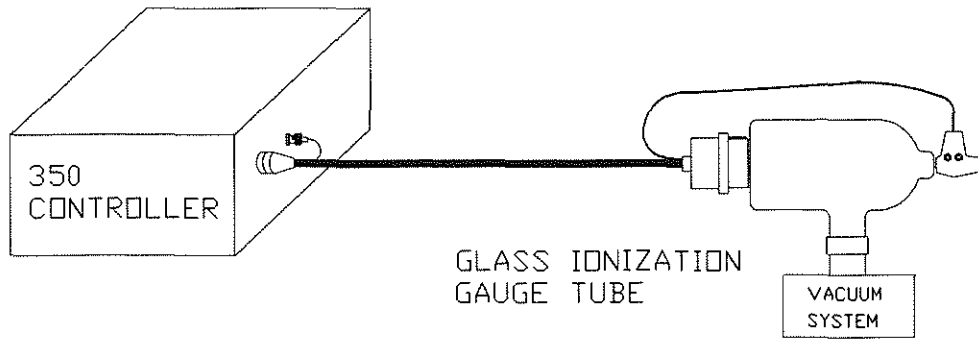

FIG 1.5

CONNECTOR COLLAR MUST BE LOCKED WITH INTEGRAL PIN GUARD ON IONIZATION GAUGE TUBE BEFORE GAUGE IS TURNED ON.

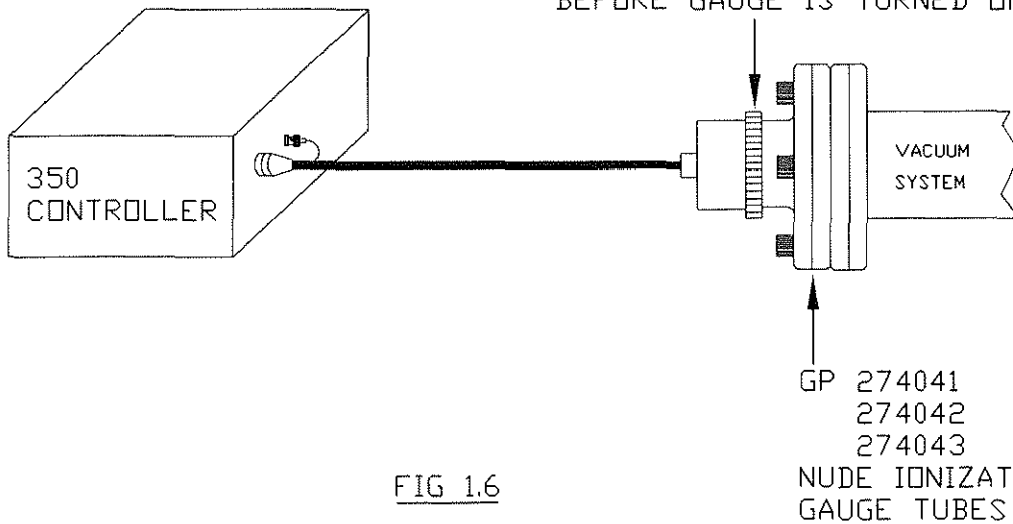

FIG 1.6

CONNECTOR COLLAR MUST BE LOCKED WITH INTEGRAL PIN GUARD ON IONIZATION GAUGE TUBE, BEFORE GAUGE IS TURNED ON

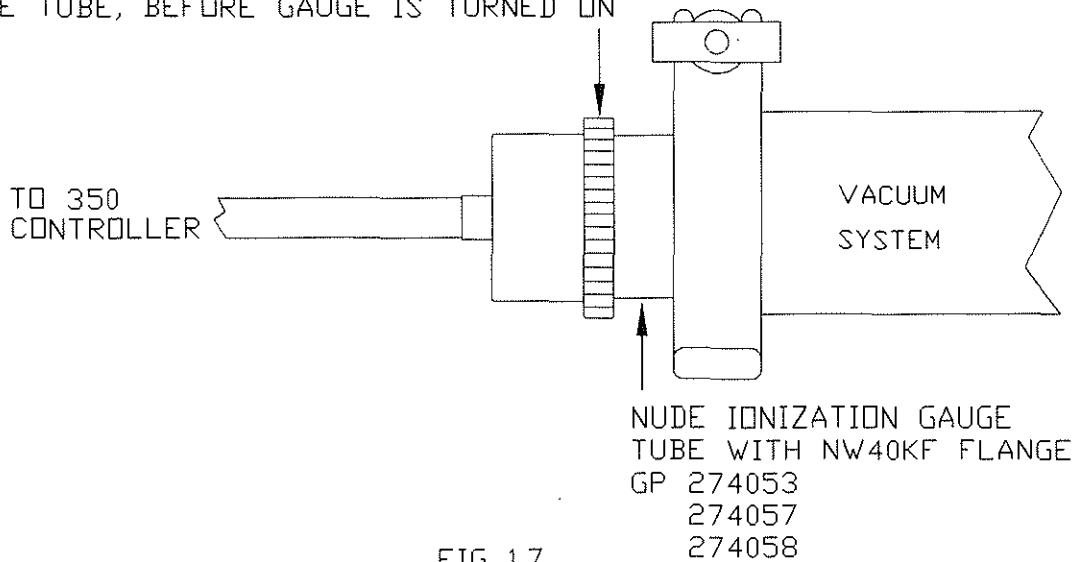

FIG 1.7

FOR USE WITH NUDE IONIZATION GAUGE (IG) TUBES WITH  
2 3/4 CONFLAT® FLANGE BUT WITHOUT INTEGRAL PIN GUARD:

A COVER ASSEMBLY GP #271025 MUST  
BE ORDERED SEPARATELY FROM  
GRANVILLE-PHILLIPS.

WHEN INSTALLING THE TUBE ON THE  
VACUUM SYSTEM INSTALL THE COLLAR  
FROM THE 271025 KIT.

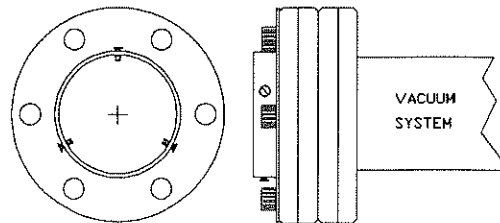

FIG 1.8

INSTALL THE SHROUD OVER THE CABLE  
AND CONNECT THE IG CABLE TO THE  
INDIVIDUAL PINS OF THE NUDE IG  
(SEE FIGS. A.1 AND A.2 ON PAGE A-1)

REFER TO FIG. 1.4 FOR PIN IDENTIFICATION

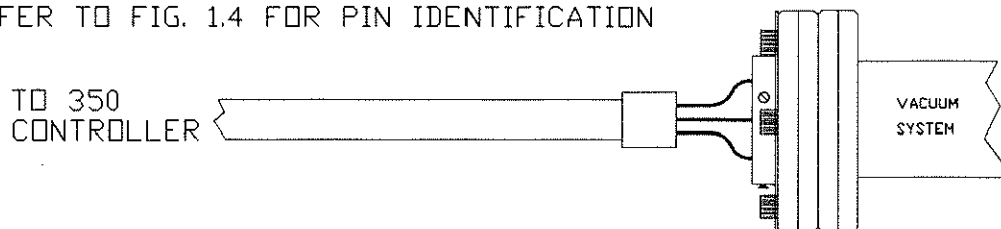

FIG 1.9

NEXT, INSTALL THE SHROUD (FROM THE G-P 271025 KIT)

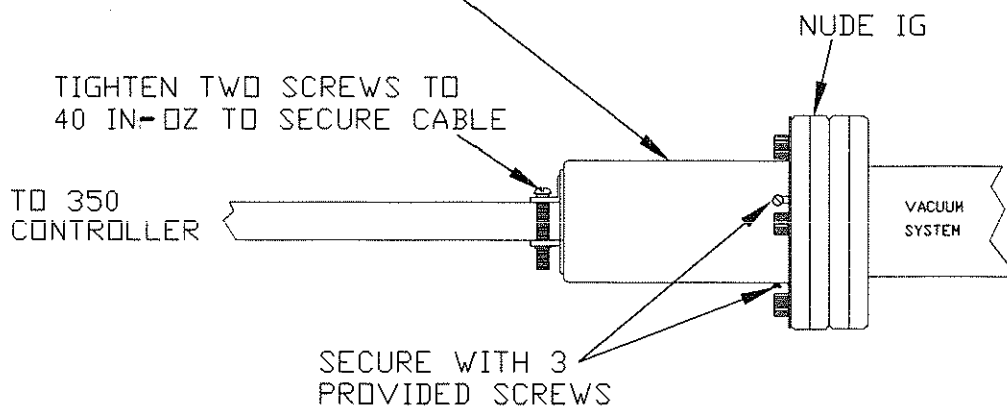

FIG 1.10

CONFLAT IS A REGISTERED TRADEMARK  
OF VARIAN ASSOCIATES.

NOTE:

1. CABLE AND NUDE IONIZATION GAUGE TUBE COMBINATIONS OTHER THAN THOSE ILLUSTRATED ABOVE AND WHICH LEAVE IONIZATION GAUGE TUBE PINS EXPOSED WITH NO LOCKING CONNECTOR OR PROTECTIVE SHROUD ARE NOT CONSIDERED AS COMPLYING WITH UL3101-1, EN61010-1 OR CAN/CSA-C22.2 NO. 1010.1-92.

## CABLE INSTALLATION STATEMENT

It is intended that all wiring either to or from the Vacuum Gauge Controller unit, whether supplied by Granville-Phillips Company or not, be installed in accordance with the safety requirements of NEC/NFPA 70. Cables provided by Granville-Phillips Company for connection to sensors or transducers is, at a minimum, designed for use as Appliance Wiring Material (UL category AVLV2), and is constructed of appropriate material and dimensions for the voltages and currents provided by the Vacuum Gauge Controller unit. It is emphasized that it is the user's responsibility to install cables to/from the Vacuum Gauge Controller whether provided by Granville-Phillips Company, or not, in accordance with the applicable local, state and national safety requirements.

Raceway and/or conduit may be needed for certain installations.

System Ground Test Procedure (Refer to the Safety Instructions on page 0.4 for further information.)

Procedure: Physically examine the grounding of both the 350 IGC and the vacuum chamber. Is there an intentional heavy duty ground connection to all exposed conductors on the vacuum chamber? There should be. Note that a horizontal "O" ring or "L" ring gasket, without metal clamps, can leave the chamber above it electrically isolated. Power can be delivered to mechanical and diffusion pumps without any ground connections to the system frame or chamber. Water line grounds can be lost by a plastic or rubber tube interconnection. What was once a carefully grounded vacuum system can, by innocent failure to reconnect all ground connections, become a very dangerous device. Use the following procedure to test each of your vacuum systems which incorporates an ionization gauge.

This procedure uses a conventional volt-ohm meter (VOM) and resistor (10 ohm, 10 watt).

1. With the gauge controller turned off, test for both dc and ac voltages between the metal parts of the vacuum chamber and the power supply chassis.
2. If no voltages exist, measure resistance. The resistance should not exceed 2 ohms. Two ohms, or less, implies commonality of these grounds that should prevent the plasma from creating a dangerous voltage between them. This test does not prove that either connection is earth ground, only that they are the same. If more than 2 ohms is indicated, check with your electrician.
3. If ac or dc voltages exist and are less than 10 volts, shunt the meter with a 10 ohm, 10 watt resistor. Repeat the voltage measurement. With the shunt in place across

the meter, if the voltage remains at 83% or more of the unshunted value, commonality of the ground is implied. Repeat the measurements several times to be sure that the voltage ratio is not changing with time. If

$$\frac{\text{Voltage}(\text{shunted})}{\text{Voltage}(\text{unshunted})} = .83 \text{ more more}$$

this should prevent the plasma from creating a dangerous voltage between these grounds. If more than 10 volts exists between grounds, check with your electrician.

4. If the voltage change in step 3 is greater than 17% due to the placement of the shunt, it complicates the measurement. The commonality of the ground may be satisfactory and the coupling poor, or the commonality could be poor! Your electrician should be asked to check the electrical continuity between these two ground systems. The placement of a second ground wire (dashed line in Fig. 1.11) between the vacuum chamber and the IGC chassis is NOT a safe answer, for large currents could flow through it. Professional help is recommended.

**WARNING** ⚠

After each maintenance/service procedure, and before operating the controller and vacuum system, make sure that your vacuum system and controller are grounded as shown in the following schematic diagram. **FAILURE TO DO SO COULD BE FATAL.**

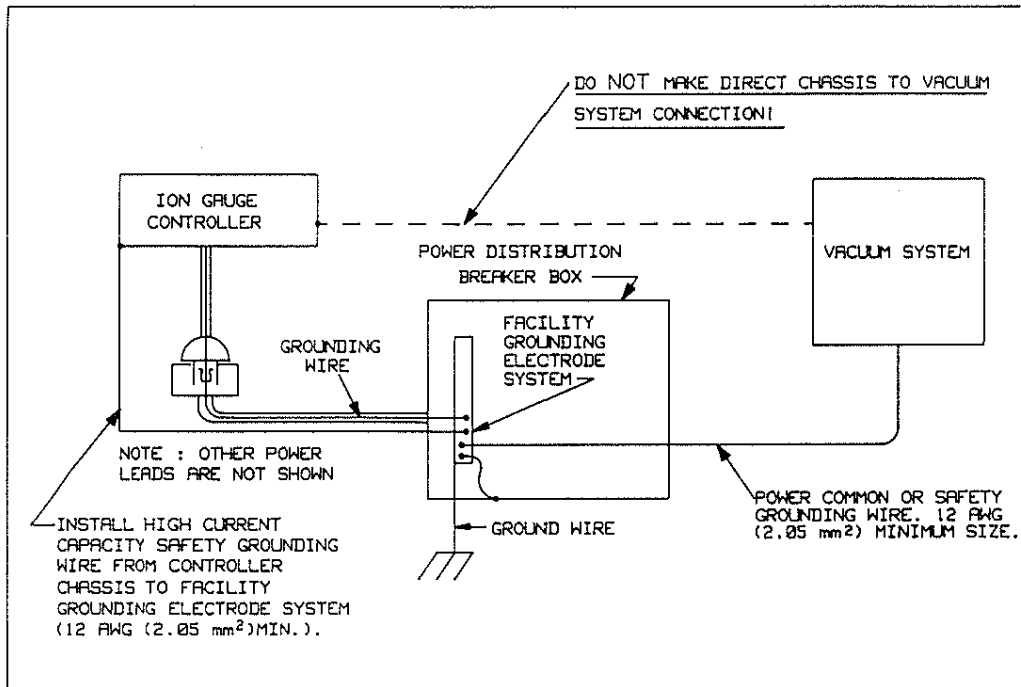

Fig. 1.11 Correct System Grounding

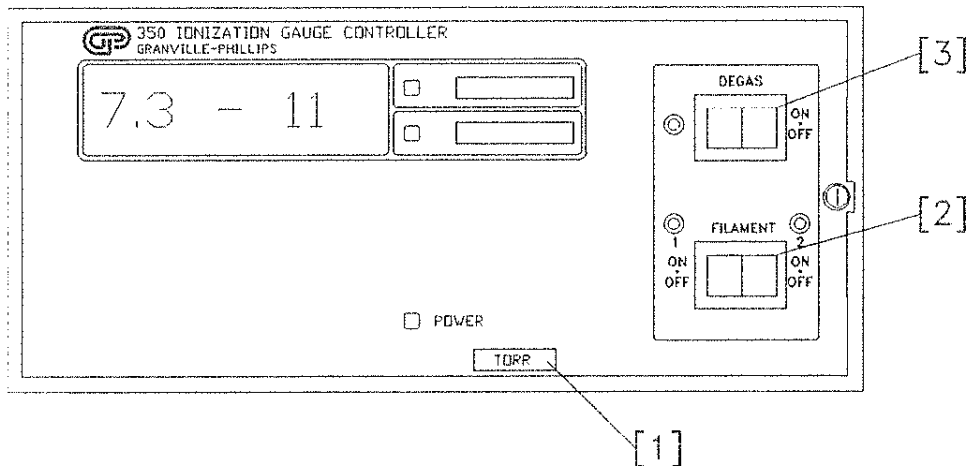

Fig. 1.12 350 IGC Control Unit Front Panel

Summary of Controls and Indicators

A description of the control and indicators found on a basic 350 IGC is given in this section. For detailed instructions pertaining to particular functions, please consult the chapter for that function.

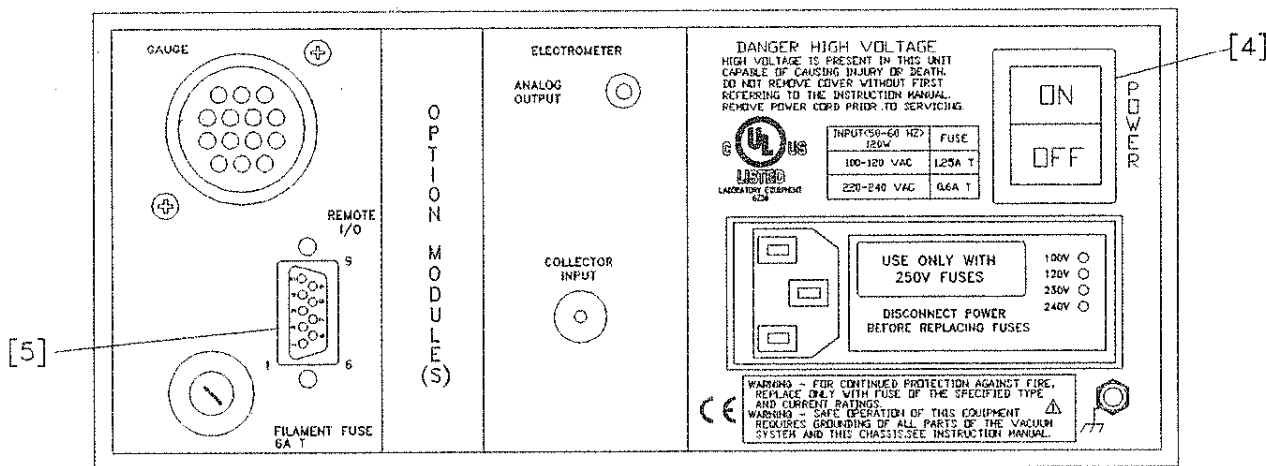

Fig. 1.13 350 IGC Control Unit Rear Panel

Units of Measure [1]

The unit of measure displayed is selectable via a switch on the Electrometer Module. These units will be indicated on the front panel label when shipped from the factory. See the electrometer chapter for instructions on changing units. The pressure units label [1] can be changed by the user if the system of units is changed. Slide the label out from the top.

Power On/Off [4]

To turn on the IGC, depress the top half of the power switch located on the rear panel. "Power On" indication is by the green LED located adjacent to the word "POWER".

To turn off the IGC, depress the lower half of the power switch.

### Ion Gauge On/Off [2]

The ion gauge may be turned on or off by the front panel momentary rocker switch or by remote control using the rear panel I/O connector.

To turn on the ion gauge from the front panel, press the momentary rocker switch [2] either to the left or right to turn on a filament of a dual filament gauge tube. If a single filament gauge tube is used it will be necessary to know which switch position was selected. To turn the gauge off, press the rocker switch again in the same direction. After an approximate 2 second delay the actual pressure will be displayed. Note: The maximum voltage appearing on the gauge tube contacts will be 5.5 Vdc when the ion gauge is off.

### Degas On/Off [3]

The EB degas may be turned on or off by the front panel momentary rocker switch, [3], or the remote control input. To turn degas on, press the degas momentary rocker switch. To turn it off, press again or press the gauge momentary rocker switch to turn off degas and turn on the gauge. There is an internal 15 minute timer which will turn off degas if not previously turned off manually.

Degas "ON" indication is by the degas LED adjacent to the word "DEGAS" on the front panel. Degas can not be activated unless the gauge has first been turned on and indicated system pressure is below  $5 \times 10^{-5}$  Torr. This prevents degas turn on at pressures where emission can not be established or where degas is of no practical use. Pressure indication is possible during degas but can be unreliable depending upon the condition of the elements. Degas power is approximately 40 W with the grid potential at 530 Vdc.

### Remote Input/Output [5]

Three TTL compatible inputs are provided through the rear panel allowing control of the ion gauge, filament 1 and 2 and degas. The function of the front panel keys must be reproduced by either a contact closure or an asserted low (0 V) logic state on these inputs. This low state must be held continuously for at least 25 milliseconds. After this, the input must be allowed to pull high for at least 105 milliseconds before another low will be accepted. These inputs have passive pull-ups.

An optoisolator is provided to indicate filament status. This has a VCEO of 40 Vdc and a current rating of 200 mAdc.



Pin No.	Function
1	Gauge Filament 1 On/Off Remote*
2	Ground
3	Not used
4	Filament status optoisolator collector
5	Filament status optoisolator emitter
6	Degas On/Off Remote*
7	Ground
8	Not used
9	Gauge Filament 2 On/Off Remote*

\*Active low inputs

Fig. 1.14 Remote Input/Output Connector

#### 1.4 THEORY OF OPERATION

##### Ion Gauge Theory

The functional parts of a typical ionization gauge are the filament (cathode), grid (anode) and ion collector, shown schematically in Fig. 1.15. These electrodes are maintained by the gauge controller at +30, +180, and 0 volts, relative to ground, respectively.

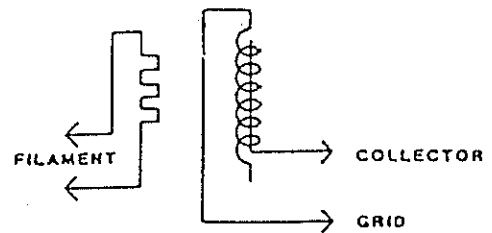

Fig. 1.15 Ion Gauge Schematic

The filament is heated to such a temperature that electrons are emitted, and accelerated toward the grid by the potential difference between the grid and filament. Most of the electrons eventually collide with the grid, but many first traverse the region inside the grid one or more times.

When an energetic electron collides with a gas molecule, an electron may be dislodged from the molecule, leaving it with a positive charge. Most ions are then accelerated to the collector. The rate at which electron collisions with molecules occur is proportional to the density of gas molecules, and hence the ion current is proportional to the gas density (or pressure, at constant temperature).

The amount of ion current for a given emission current and pressure depends on the ion gauge design. This gives rise to the definition of ion gauge "sensitivity", frequently denoted by "K":

$$K = \text{ion current} / (\text{emission current} \times \text{pressure})$$

Nude Bayard-Alpert type gauges typically have sensitivities of 25/Torr when used with nitrogen or atmosphere although this can vary as it is dependent upon the distance of the gauge tube elements to surrounding elements of the vacuum system. Sensitivities for other gases are given in section 2.3.

The ion gauge controller varies the heating current to the filament to maintain a constant electron emission, and measures the ion current to the collector. The pressure is then calculated from these data.

Ion gauge degas is accomplished by electron bombardment of the grid. During EB degas, the grid potential is raised to 530 Vdc and 40 watts is dissipated.

### Microcontrollers and Bus Structure

The Electrometer Module in the 350 has a dedicated microcontroller with internal ROM, RAM, timing, and interrupt management functions.

The microcontroller is equipped with a watchdog timer, which automatically generates a reset if the processor fails to fulfill timing "checkpoints" within its code. Inter-processor communication is accomplished via the display bus. These lines carry BCD-format pressure data which is used to generate the 350 display.

## 1.5 SPECIFICATIONS

### Physical

Width	241 mm (9.5 in.) with 1/2 rack mounting ears.
Height	89 mm (3.5 in.)
Depth	356 mm (14 in.) includes 76 mm (3 in.) for connectors and cables.
Weight	4.8 kg (10.5 lbs.)

### Electrical

Voltage	90-130 Vac or 200-260 Vac
Frequency	50 to 60 Hz
Power	120 watts max.
Fuse Ratings	AC Line 100-120V - 1.25A Time Lag (T) Littelfuse 3131.25
	AC Line 200-240V - .60A Time Lag (T), Littelfuse 313.600
	+/- 20 V supplies - Granville-Phillips P/N 013132 1.5 A slow-blow Littelfuse 22901.5

Grid Supply - Granville-Phillips  
P/N 013193  
0.1 A, 500 V, slow-  
blow  
Bussman FNQ-1/10  
Gould-Shawmut  
ATQ 1/10

Filament Supply - Granville-Phillips  
P/N 013192  
6.0 A slow-blow  
Bussman MDL-6

Environmental Conditions Indoor use.  
Altitude up to 2000 meters.  
Temperature 0 °C to 40 °C.  
Maximum relative humidity 80% for  
temperatures up to 31 °C decreasing  
linearly to 50% relative humidity at 40  
°C.  
Transient overvoltages accord-  
ing to INSTALLATION CATEGORY (over-  
voltage category) II.  
POLLUTION DEGREE 2 in accord-  
ance with IEC 664.

Pressure Range

Emission Range		
.01 mA to .1 mA	.1 mA to 1 mA	1 mA to 10 mA
1 x 10 <sup>-9</sup> to 1 x 10 <sup>-2</sup> Torr	1 x 10 <sup>-10</sup> to 1 x 10 <sup>-3</sup> Torr	1 x 10 <sup>-11</sup> to 1 x 10 <sup>-4</sup> Torr
Readable to		
1 x 10 <sup>-10</sup> Torr	1 x 10 <sup>-11</sup> Torr	1 x 10 <sup>-12</sup> Torr

Internal overpressure limiter is factory adjusted to trip at 1-  
decade below the upper limits specified above. See section 2.4 for  
readjustment instructions.

Electronic Accuracy Typical ± 3% of reading at ambient  
temperature of 25 ± 5 °C.

Display Units Torr unless otherwise requested.  
Adjustment and internal selector switch  
provides readout in mbar or pascal.

Display Resolution Scientific notation, 2 significant  
digits.

Display Update Time 0.5 sec. typical as shipped. Internal switch selectable to 3 sec. reading averaged.

#### Ion Gauge

Sensitivity 3/Torr to 50/Torr (factory setting is 25/Torr).

Emission Current 10  $\mu$ A to 10 mA in 3 decade ranges (factory setting is 1 mA).

Collector Potential 0 V

Grid Potential +180 V during normal operation  
+530 V during degas operation

Filament Potential +30 V

Degas EB: 40 watts approximate with 15 minute turn off timer.

Analog Output 0-10 V; Logarithmic; 1V/decade.

#### Remote I/O

Gauge and Degas On/Off Inputs Less than 0.4 V @ 10  $\mu$ A for 25 msec (min.). Must go to greater than 3.5 V for 105 msec (min.) before next low state.

Filament Status Optoisolator transistor, open collector and emitter, 40 VCEO, 200 mA.

## CHAPTER 2 - THE ION GAUGE ELECTROMETER MODULE

### 2.1 INTRODUCTION

The ion gauge (IG) Electrometer Module provides ion gauge pressure readout from less than  $1 \times 10^{-11}$  Torr ( $1.3 \times 10^{-10}$  mbar or  $1.3 \times 10^{-8}$  Pa) to  $1 \times 10^{-2}$  Torr, air equivalent, depending on the gauge and emission current used.

Adjustments are provided for gauge sensitivity and emission current. Adjustment and an internal switch allow change to mbar or Pascal pressure units, and a user selectable "slow update" feature triggers measurement averaging, resulting in a display update frequency of about once every three seconds. The overpressure shutdown threshold is internally adjustable. An internal switch defeats the 15 minute degas timer turn off feature.

### 2.2 INSTALLATION

#### Units of Measure

Your unit will have been shipped from the factory preset to display the unit of measure, torr, millibar or pascal, that you requested. If you wish to change units, proceed as follows:

1. Shut off power to the control unit.
2. Remove the top cover. Locate the IG Electrometer Module.
3. Locate [7], display units control switch.
4. Set switch to desired position, off = torr/mbar units, on = pascal units.
5. Slip the label card out of the top of the front panel and apply the appropriate pressure units label.

Selection between torr and mbar units is done by adjusting the IG tube sensitivity to the appropriate units. For example, a typical nude Bayard-Alpert tube has a sensitivity of 25/Torr or 18.75/mbar. Thus, for this tube, adjusting the sensitivity for a display reading of 2.5+1 will result in display of pressure in Torr. Adjusting to 1.9+1 will result in display in mbar.

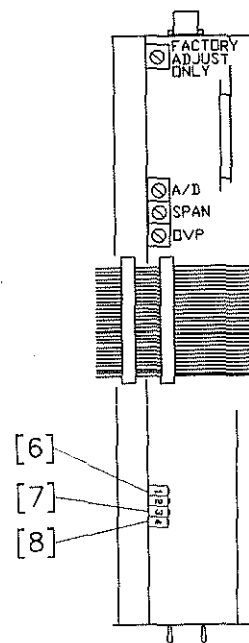

Fig. 2.1 Ion Gauge Electrometer Module Top View

### Display Update Rate Switch

Locate [8] slow update switch. Setting this switch "ON" will enable pressure averaging. The display will update about every 3 seconds rather than the normal 0.5 sec typical period.

### Degas Timer Override

Locate [6] degas timer override switch. Setting this switch "on" will disable the 15 minute turn off timer.

## 2.3 OPERATION

### Displaying Sensitivity and Emission with the Calibration Switch [9]

This switch is used for displaying pressure, gauge sensitivity or emission current. It is activated by setting either to the left or right of the center (CAL) position. The function depends on the operating state of the ion gauge tube.

If the tube is off, setting the switch displays the tube sensitivity in scientific notation.

If the tube is on, the switch displays emission current in amperes. Note the display will blink at a two second rate in this mode to warn the user that pressure is not being displayed.

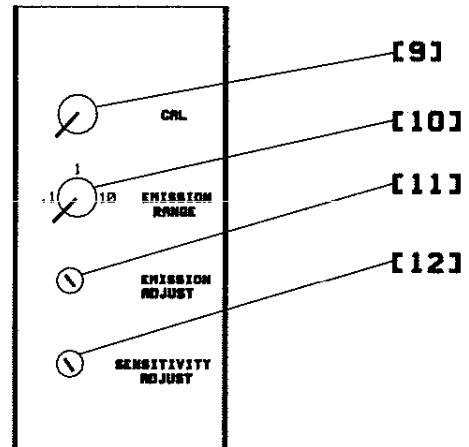

Fig. 2.2 Electrometer Module Front Panel

### WARNING

Do not leave the calibration switch set after you are done viewing sensitivity or emission; otherwise, the display reading may be mistaken for an actual pressure reading.

### Emission Range Switch [10]

This switch selects between three emission ranges; 0.1 milliamperes, 1.0 milliamperes, or 10.0 milliamperes. Adjustment within each range is achieved with the emission adjustment pot.

In general, higher emissions are used at lower pressures. If you are measuring very low pressures or have a low-sensitivity IG tube, the 10.0 mA range is better. This is true even for a nude Bayard-Alpert gauge having a sensitivity of 25/Torr. The 10 mA of emission will generate additional ions and improve the signal to noise ratio of the electrometer without appreciably affecting filament life.

Note that changing the emission range by one decade will also change the overpressure shutdown point by one decade. See section 2.4, "Electrometer Calibration" for details of the overpressure shutdown adjustment. Adjustment of emission within a range (see below) will not affect the overpressure shutdown point.

#### Emission Adjustment [11]

This potentiometer provides control of the emission within the decade value selected by the emission range switch. The calibration switch must be set with the IG tube turned on to view emission during adjustment. The span of adjustment is from approximately 10% to 120% of the range value.

Please note that on some earlier generation IG controllers, the emission current adjustment was used to correct for varying tube sensitivities. This is not appropriate on the 350 controller, as an independent sensitivity adjustment is provided (see below).

Theoretically, varying the emission current will not affect the pressure reading since the electrometer is actually calculating:

$$P = \frac{I+}{S(I-)} \text{ or Pressure} = \frac{\text{Collector Current}}{\text{Sensitivity}(\text{Emission current})}$$

In actuality, there will be slight differences dependent on gauge cleanliness and gauge pumping.

#### Sensitivity Adjustment [12]

This adjustment is used to match tubes of different sensitivities. The calibration switch [9] must be set left or right with the IG off to view sensitivity during the adjustment.

The IGC is shipped from the factory set for a tube sensitivity of 25/Torr, as is typical for nude Bayard-Alpert type tubes such as the Granville-Phillips 274022 and 274023. The approximate range of the adjustment is 3 to 50/Torr. If the actual 'S' of the gauge tube being used is different than 25/Torr, the sensitivity adjustment should be set to that of the gauge tube; otherwise, measurement error will result.

#### Relative Gas Sensitivities

Sensitivity depends on the gas being measured as well as the type of IG tube. Fig. 2.3 lists the relative gauge sensitivities for common gases. These values are from NASA Technical Note TND 5285, "Ionization Gauge Sensitivities as Reported in the Literature", by Robert L. Summers, Lewis Research Center, National Aeronautics and Space Administration. Refer to this technical note for further definition of these average values and for the gauge sensitivities of other gases.

To adjust the 350 IGC to be direct reading for gases other than air or N<sub>2</sub>, calculate the sensitivity K<sub>x</sub> for gas type x as follows:

$$K_x = (R_x) (KN_2)$$

where KN<sub>2</sub> is the gauge sensitivity for N<sub>2</sub> and R<sub>x</sub> is found from Fig. 2.3.

GAS	R <sub>x</sub>	GAS	R <sub>x</sub>
He	0.18	H <sub>2</sub> O	1.12
Ne	0.30	N <sub>2</sub> O	1.16
D <sub>2</sub>	0.35	Ar	1.29
H <sub>2</sub>	0.46	CO <sub>2</sub>	1.42
N <sub>2</sub>	1.00	Kr	1.94
Air	1.00	SF <sub>6</sub>	2.5
O <sub>2</sub>	1.01	Xe	2.87

Fig. 2.3 Relative Gas Sensitivities

### Analog Output

This voltage is proportional to the logarithm of the pressure, scaled to 1 volt per decade with 0 volts at 1 x 10<sup>-12</sup> Torr at 10 mA emission current. Emission range setting affects the scaling of the analog output, see Fig. 2.5. When the IG is turned off, the output will switch to slightly over +10 V.

A standard 1/8" miniature phone jack connector is supplied.

For 10mA emission, PRESSURE=10<sup>(volts-12)</sup>.  
 For 1mA emission, PRESSURE=10<sup>(volts-11)</sup>.  
 For .1mA emission, PRESSURE=10<sup>(volts-10)</sup>.

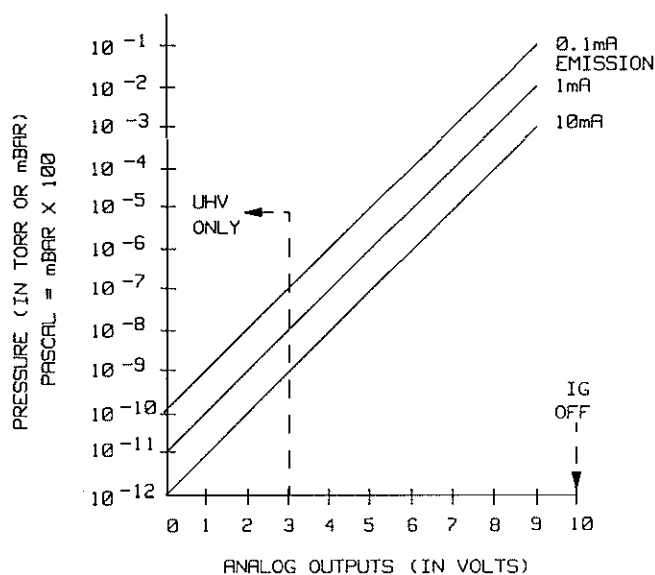

Fig. 2.4 Analog Outputs (in volts)



## 2.4 ELECTROMETER CALIBRATION

Refer to section 2.3 for instructions on calibrating ion gauge sensitivity and emission current.

Electrometer Span Adjustment. [13] - This is a factory calibration point and should not normally be changed by the user.

Overpressure Shutdown Adjustment. [14] - This control is factory set so the ion gauge will shut down when the pressure rises above the following levels:

Emission Current (milliamperes)	Overpressure point (Torr)
0.1 range	$1 \times 10^{-3}$
1.0 range	$1 \times 10^{-4}$
10.0 range	$1 \times 10^{-5}$

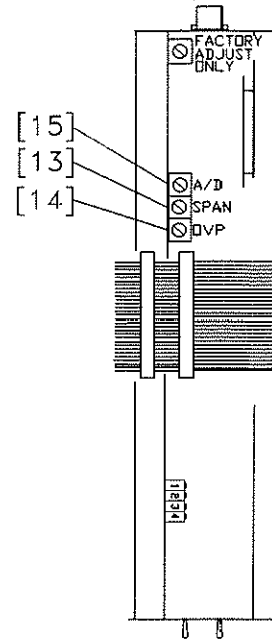

Fig. 2.5 Ion Gauge Electrometer Module

The overpressure shutoff point does not depend on the adjustment of the emission level within a range.

To adjust the overpressure shutoff point to a different level:

1. Maintain system pressure at the desired shutoff point.
2. Rotate the overpressure adjustment potentiometer fully counter-clockwise.
3. Turn on the ion gauge.
4. Rotate the adjustment pot clockwise slowly until the IG turns off.

A/D calibration. [15] - Factory set, do not adjust.

# NOTES

## CHAPTER 3 - THE PROCESS CONTROL MODULE

### WARNING

It is the installers responsibility to ensure that the automatic signals provided by the Process Control Module are always used in a safe manner. Carefully check manual operation of the system and the setpoint programming before switching to automatic operation.

Where an equipment malfunction could cause a hazardous situation, always provide for fail-safe operation. As an example, in an automatic backfill operation where a malfunction might cause high internal pressures, provide an appropriate pressure relief device.

### 3.1 INTRODUCTION TO THE PROCESS CONTROL MODULE

A Process Control Module provides the 350 Vacuum Gauge Controller with single-pole, double-throw relays that may be controlled either by digital setpoints or by the built-in manual override switches.

### 3.2 PROCESS CONTROL MODULE INSTALLATION

#### Process Control System Connections

Prior to connecting the process controls to the system, it is recommended that the following steps be followed. If application assistance is desired, contact a Granville-Phillips application engineer.

1. Unless the control logic is simple and obvious, develop a logic diagram of the process control function.
2. Prepare a specification table which lists the proposed pressure setting, system measurement point, and polarity for each PC channel.
3. Draw a circuit schematic which specifies exactly how each piece of system hardware will be connected to the 350 process control relays.
4. Check that the power required for the load is within the specified ratings of the relay.
5. With the Process Control Module connector disconnected from the Process Control Module, connect the process control cable to the devices to be controlled.

6. Ensure that all devices are under manual control before connecting to the Process Control Module.

#### To Display a Setpoint

1. Be sure the "CAL" switch of the electrometer is in its center position, or the calibration data in display line 1 will conflict with the display of setpoints 1 and 2.
2. Set selector switch [19] to the number of the channel you wish to display.
3. Press either setpoint display/set button, [17] or [18] and release. The setpoint will appear for 2 seconds in the same display.

#### To Modify a Setpoint

1. Set the selector switch [19] to the number of the channel you wish to modify.
2. Press and hold the setpoint SET button for the direction you wish the setpoint to change, up, [17] to raise the setpoint, down, [18] to lower it.
3. The setpoint will scroll until the button is released. It will scroll slowly until a decade boundary is crossed and then will speed up to facilitate rapid changes across many decades. Release the button when you have entered the desired decade, and then re-depress it to scroll slowly within the decade to reach the exact setpoint needed.

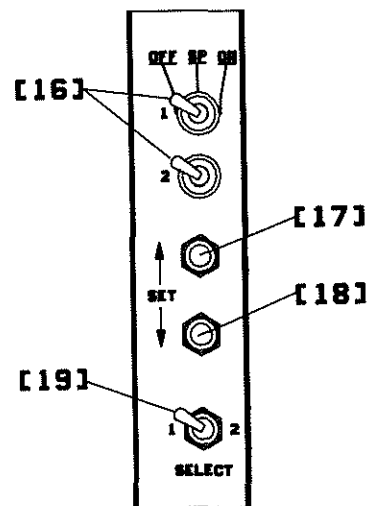

Fig. 3.1 Process Control Module, Front Panel

After the setpoint button is released, the display will return to pressure data after two seconds. At this time the new setpoint will be deposited in non-volatile memory.

Note that if the ion gauge is off, PC relays 1 and 2 will deactivate.

Relay Polarity Setting

The relays can be set to activate with pressure either above or below the set point. A switch is provided for each channel. For activation below the set point, the switch should be in the OFF position. This is the factory setting. Refer to the numbers on the printed circuit board--not on the switch body itself--for the number.

For two channel process control, switches 1 and 2 set the polarity for set points 1 and 2.

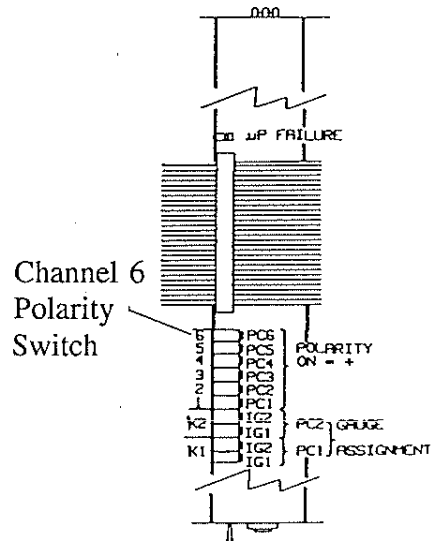
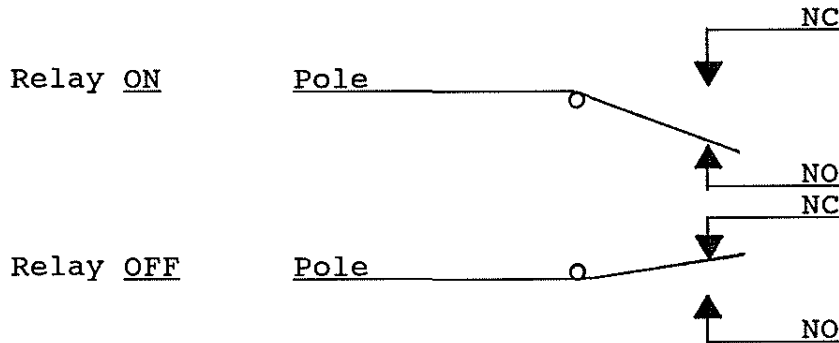

Fig. 3.2 Process Control Module, Top View

Relay Disable

The K1 pair of switches can be used to enable or disable PC1. Set both switches to OFF to enable PC1 to be activated by the IG pressure. Setting both switches ON will set the PC1 relay to be always off. K2 switches control PC2 similarly. The switches are factory set to enable the relays. The following figure shows the status of the process control relay contacts for the ON and OFF conditions.



See Fig. 3.3 for Process Control connector relay contact/pin assignments.

Pin Assignment

The following pins are used on the process control module rear panel connector.

Pin Letter	Function
W	Channel 1 relay common
P	Channel 1 relay N.C.
T	Channel 1 relay N.O.
H	Channel 2 relay common
A	Channel 2 relay N.C.
D	Channel 2 relay N.O.

Fig. 3.3 Pin Assignments/Process Control Connector

### 3.3 PROCESS CONTROL OPERATION

At all times the status of the 2 relays is displayed in the relay status LEDs on the 350 front panel. Note that these LEDs do not indicate whether the gauge pressure is above or below the programmed setpoint, since manual override status may result in activation above or below the setpoint.

#### Setpoint Display and Adjustment

Setpoints are stored in non-volatile memory, and are specified by a 2-digit mantissa and 2-digit exponent. They may be set anywhere in the range  $1 \times 10^{-12}$  to  $9 \times 10^{+5}$ . This allows for the entire pressure range of all supported transducer types and systems of units.

The setpoint is compared directly to the display data, so units of measure are implicit. Changing the units switch on the gauge control modules will not change the stored setpoints. They must be re-programmed in the new system of units.

No change in status of relays 1 and 2 will occur during degas. They will function as if the pressure was frozen at the instant degas was initiated. This is because large pressure variations may occur in an ion gauge tube under degas.

There is a programmed 10% hysteresis on each process control setpoint. For example, with a pressure setpoint of  $6.3 \times 10^{-6}$  Torr the relay will activate when the display reaches  $6.2 \times 10^{-6}$  Torr (for falling pressure) and will de-activate when the pressure rises to one significant digit above the setpoint plus 10%, i.e.,  $6.3 \times 10^{-6} + 0.6 \times 10^{-6} + 0.1 \times 10^{-6}$  or  $7.0 \times 10^{-6}$  Torr. For setpoints where the 2nd digit is 0.5 or greater the 10% value is rounded up. For example, if the setpoint is programmed to  $6.6 \times 10^{-6}$  Torr the relay will activate at  $6.5 \times 10^{-6}$  Torr (on falling pressure) and will de-activate when the pressure rises to  $6.6 \times 10^{-6} + 0.7 \times 10^{-6} + 0.1 \times 10^{-6}$  or  $7.4 \times 10^{-6}$  Torr.

Since the process control and computer interface modules derive their pressure data directly from the display bus, they will be unable to update their pressure data while setpoints are being displayed. They will not mistakenly interpret setpoint data as pressure data, but will simply retain the last displayed pressure data until the SET key is released.

## Manual Override [16]

These two three-position switches on the front of the process control module allow override of the programmed setpoints at any time. When moved to the right, the relay is activated. When moved to the left, the relay is de-activated. When left in the center position, the relay is controlled automatically.

### 3.4 PROCESS CONTROL THEORY OF OPERATION

The Process Control Module contains a dedicated microcontroller and a non-volatile memory chip for storage of the setpoints. This chip has a rated life of 10,000 erase/write cycles for each setpoint, and will retain data for 10 years. Since data is read/written to this chip serially, it is necessary to store working copies of the setpoints in internal RAM memory.

The microcontroller compares the setpoints with the pressure display data on the display bus and makes a decision as to whether or not to activate a channel's relay.

The manual override switches, when thrown in one direction or the other, take precedence over the microcontroller's decision.

### 3.5 PROCESS CONTROL SPECIFICATIONS

Number of channels	2
Pressure range	$1.0 \times 10^{-12}$ to $9.9 \times 10^5$ .
Hysteresis	10%
Setpoint adjustment	Digital, 2 significant digits plus exponent.
Output relays	
Contact rating	5 A @ 30 Vac, or 5 A @ 30 Vdc, resistive load.
Contact style	SPDT

# NOTES



## CHAPTER 4 THE RS-232 MODULE

### 4.1 INTRODUCTION

The RS-232 Interface Module for the 350 Ion Gauge Controller allows data output to, and ion gauge control by, a host computer. Output is either by a command-response mechanism or by a talk-only mode which is invoked via a switch on the RS-232 board.

A variety of baud rates and byte framing options are available, as well as switches to force the handshake lines to an "always true" condition.

### 4.2 RS-232 INSTALLATION

**350 RS-232 factory defaults are: 300 BAUD, 7 data bits, no parity, 2 stop bits; DCD, CTS, DSR forced "true".**

The interface protocol is set using 8 switches. Figure 4.1, reference [20], designates switch number 1.

#### Selecting the Byte Format

##### Baud Rate

Dip switches 6-8 are used to control the baud rate. The settings are:

<u>S6</u>	<u>S7</u>	<u>S8</u>	<u>BAUD RATE</u>	<u>S6</u>	<u>S7</u>	<u>S8</u>	<u>BAUD RATE</u>
On	On	On	9600	Off	On	On	600
On	On	Off	4800	Off	On	Off	300
On	Off	On	2400	Off	Off	On	150
On	Off	Off	1200	Off	Off	Off	75

##### Character Framing

Switches 3-5 control number of characters, parity, and number of stop bits:

<u>S3</u>	<u>S4</u>	<u>S5</u>	<u>CHARACTER BITS</u>	<u>PARITY</u>	<u>STOP BITS</u>
On	On	On	8	None	2
On	On	Off	8	Even	1
On	Off	On	8	Odd	1
On	Off	Off	7	None	2
Off	On	On	7	Even	1
Off	On	Off	7	Odd	1
Off	Off	On	7	Even	2
Off	Off	Off	7	Odd	2

### Talk-Only Mode

Switch S1, [20] , if off at power-up, puts the interface in talk-only mode. The pressure data from all three displays will be output in a single message string, separated by commas, approximately every 5 seconds.

### Handshake Line Control Switches

Refer to Section 4.4 for more detailed information on the handshaking mechanism.

Switches [22],[23], and [24], when in the "up" position, force the handshake lines data-carrier-detect (DCD), clear-to-send (CTS), and data-set-ready (DSR), respectively, to a logic true condition. As shipped from the factory, these lines are forced true.

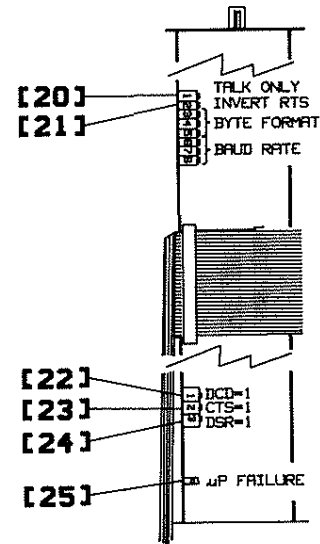

Fig. 4.1 RS-232 Module Top View

### Invert RTS Switch

As shipped from the factory, the request-to-send (RTS) control line is set to operate as a modem line per the RS-232 standard. In some implementations it is necessary to invert this line and hook it directly to the clear-to-send (CTS) line of the host computer.

Switch S2, if OFF when the 350 goes through its power-up sequence, tells the RS-232 interface to invert the polarity of the RTS line. See Section 4.4, for more details.

## 4.3 OPERATION

Consult the user's manual for the host computer to be sure the protocol used is in accord with that established via the switch configuration you have chosen for the 350 RS-232 module.

Communication with the 350 VGC is via ASCII strings. A message to the 350 consists of a command and a command modifier, followed by a terminator. The message may contain leading spaces, and the command and modifier may optionally be separated by spaces or commas. No spaces may appear within the command or the modifier, only between them.

The terminator expected by the 350 is an ASCII carriage-return line-feed, denoted here by CRLF. The carriage-return is optional, and messages terminated with only the line-feed will be accepted. Note that the CRLF terminator is, in general, appended automatically by the host computer's interface software to the message string supplied by the user.

If extra characters are found in the message after it has been successfully interpreted but before the terminator, they will be ignored.

All characters should be upper-case.

All messages to the 350 will receive a reply, consisting of an ASCII string terminated with CRLF. Numbers will be returned in the format X.XXE±XX.

### Command Syntax

#### **DG**

Definition: Turn degas on or off  
Modifiers: **ON** or **OFF**  
Response: **OK** if command accepted, or **INVALID** if rejected.

Example: From computer: **DG ON CRLF**  
From 350: **OKCRLF**

#### NOTES

- 1) Command is **INVALID** if neither IG filament is on.
- 2) A response to the **DG ON** command of **OK** indicates only that a signal requesting degas has been sent to the electrometer. Degas will fail to activate if the pressure is above  $5 \times 10^{-5}$  Torr. Use the **DGS** command (see below) to verify that degas has been successfully initiated.

#### **DGS**

Definition: Display degas status  
Modifiers: None  
Response: ASCII **1** if degas is on, **0** if degas is off

Example: From computer: **DGSCRLF** (Note: Spaces may be omitted)  
From 350: **1CRLF**  
(Indicating degas is on)

#### **DS IG**

Definition: Display pressure reading  
Response: ASCII string representing the pressure

Example:           From computer: **DS IG CRLF**  
                  From 350:       **1.20E-07CRLF**

NOTE: If the ion gauge is turned off, or is in its first few seconds of operation, the 350 will return **9.90E+09**.

The **DS IG** command will return pressure if either filament is on, and **9.90E+09** if neither is on.

## **IG1**

Definition:       Turn IG filament 1 on or off  
Modifiers:        **ON** or **OFF**  
Response:         **OK** if command accepted, **INVALID** if rejected

Example:           From computer: **IG1 ON CRLF**  
                  From 350: **OKCRLF**

### NOTES:

- 1) The **IG1 ON** command will be rejected as **INVALID** if Filament 1 is already on, and **IG1 OFF** will be rejected if Filament 1 is already off.
- 2) A response to the **IG1 ON** command of **OK** indicates only that a signal requesting that Filament 1 be turned on has been sent to the electrometer. The tube may fail to come on, e.g., if the system pressure is too high or if the tube is disconnected. To verify that Filament 1 is on, use the **DS IG1** command. If the tube is off (or in its first few seconds of operation after being turned on) a pressure of **9.90E+9** will be returned.

## **IG2**

Identical to **IG1**, but applies to Filament 2.

### Error Messages

If an error is found in the incoming message, the following messages will be returned in place of the normal response:

- |                      |   |   |
|----------------------|---|---|
| <b>OVERRUN ERROR</b> | - | Returned if the incoming message overflows the 350's buffer. This may indicate a flaw in the host software.                                 |
| <b>PARITY ERROR</b>  | - | Returned if the parity of a byte in the incoming message does not match that programmed by the switches.                                    |
| <b>SYNTAX ERROR</b>  | - | Returned if the message fails to parse as a valid 350 command. Could also result from failure to assert DCD during transmission to the 350. |

#### 4.4 RS-232 THEORY OF OPERATION

##### Handshaking

The 350 RS-232 interface implements the following signals:

FIG. 4.2 RS-232 CONTROL LINES

SIGNAL	PIN #	DIRECTION
Protective Ground	1	-
Transmitted Data	2	To computer
Received Data	3	To 350
Request to Send (RTS)	4	To computer
Clear to Send (CTS)	5	To 350
Data Set Ready (DSR)	6	To 350
Signal Ground (common return)	7	-
Data Carrier Detect (DCD)	8	To 350
Data Terminal Ready (DTR)	20	To computer

The DTR line is set true on power up to indicate it is on line. When the 350 receives a start bit on the received data line it will input and buffer a character. The DCD line must be true at the time each character is received or that character will be ignored. The 350 will continue to receive and buffer characters until the terminator (LF) is received.

Upon receiving the terminator, the 350 will assert the RTS line as a holdoff, to prevent the host computer from attempting to transmit further data until the message just received has been decoded and a reply has been output.

During output of the reply, the incoming handshake lines CTS, and DSR are tested prior to beginning transmission of each character. The 350 will wait until both are true before beginning transmission of a character, and will not test them again until ready to begin transmitting the next.

After transmitting the terminator, the 350 will negate RTS and wait for the next incoming message.

To summarize:

##### CTS, DSR

Set by the computer to indicate that the 350 may output the next byte in its message. As shipped from the factory these lines are forced "TRUE" by the switch settings of the 350 RS-232 printed circuit board, thus the 350 will automatically assume the host is ready to receive. See Fig. 4.1 for the location of these switches.

## DCD

Tested when a character is received. The character will be ignored unless DCD is "TRUE". As shipped from the factory this line is forced "TRUE" by the switch settings.

## DTR

Always asserted by the 350. A "power on" indication.

## RTS

Negated by the 350 on power-up. Asserted upon receipt of a message terminator. Negated after transmitting the terminator of the 350's response to that message.

## Reversing the Polarity of RTS

If switch 2, [21], is open on power-up, the 350 will apply the opposite polarity to RTS from that described above. When used in this mode RTS may be connected to the CTS input of the host computer. This violates the RS-232 standard, but is a commonly used implementation.

### **4.5 RS-232 TROUBLESHOOTING**

Because the RS-232 "standard" is found in a bewildering array of configurations, the first thing to do if trouble arises is check the following configuration options:

1) Check switch settings.

Be sure baud rate, character format and framing, and interface protocol are matched to your host computer or terminal's requirements. Note that there may be several mismatched parameters. Check to see if your computer requires the reversed-polarity RTS convention.

2) Check interface wiring.

The pin designations for the RS-232 connector are shown in Fig. 4.2. Note that the "received" and "transmitted" data lines are defined as seen by the 350. Many companies supply "null modems" or switch boxes for the purpose of reconfiguring the control lines for particular applications.

3) Check command format.

Be sure the strings you output to the 350 are in accord with the syntax defined in Section 4.3.

## RS-232 Troubleshooting Guide

<u>SYMPTOM</u>	<u>POSSIBLE CAUSE</u>
Microcontroller reset LED [25] lit or flashing.	Microcontroller failure.
No response or garbled output.	Baud rate incorrect. Character length incorrect or stop bit(s) incorrect.
OVERRUN ERROR message.	Stop bit(s) incorrect, host software failure.
PARITY ERROR message. SYNTAX ERROR message.	Parity incorrect. Message to the 350 not in accord with specified syntax. Could also result from failure to assert DCD handshake line.

### 4.6 RS-232 SPECIFICATIONS

Format	EIA standard RS-232-C, half duplex, asynchronous.
Data Rates	75,150,300,600,1200,2400,4800,9600 baud.
Character length	7 or 8 bit ASCII, switch selectable.
Parity	Odd, even, or none, switch selectable.
Stop bits	1 or 2. 8 character bits plus parity allows only 1 stop bit.
Handshake	Outputs: DTR,RTS. RTS polarity selectable. Inputs: DSR, CTS, DCD. May be forced to logic "TRUE" with switches.
Logic levels	Inputs: Logic 1, 2.0 Vdc min.,15 Vdc max.  Logic 0, -15 Vdc min.,0.75 Vdc max.  Input Current: 4.0 mA max @ Vin = +15 Vdc.  -4.0 mA max @ Vin = -15 Vdc.

# NOTES



## CHAPTER 5 THE CONVECTRON GAUGE MODULE

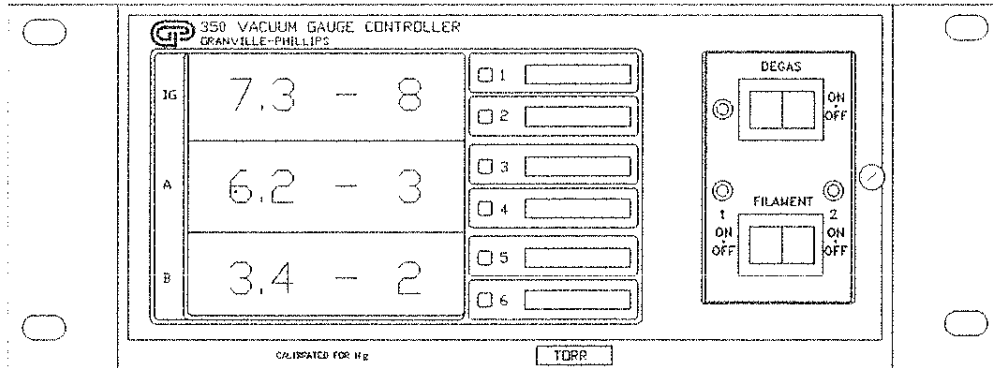

Typical 350 Front Panel  
with 3-line Display and Process Control Status Indicators

Some versions of Series 350 are configured to display pressure for an ion gauge (IG) and two *CONVECTRON* Gauges (A,B) when the 2-channel *CONVECTRON* option module is installed.

The *CONVECTRON* option module can be used to automatically turn-ON filament 1 of the ion gauge. If Auto IG-ON is not desired, adjust the IG ON potentiometer to the OFF position (full CCW).

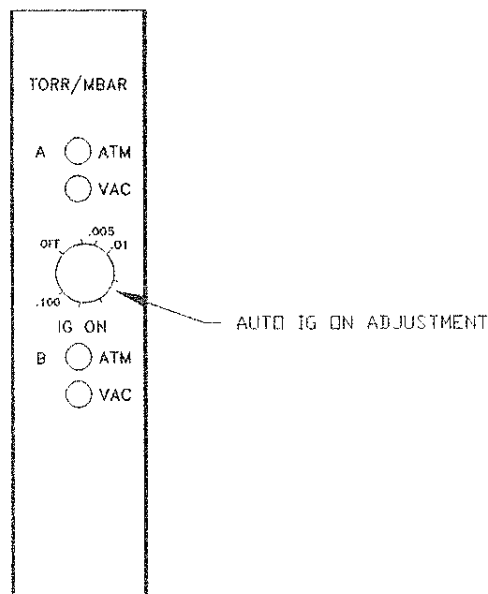

Convectron Option Front Panel

## SAFETY INSTRUCTIONS

SAFETY PAYS. THINK BEFORE YOU ACT. UNDERSTAND WHAT YOU ARE GOING TO DO BEFORE YOU DO IT. READ THIS INSTRUCTION MANUAL BEFORE INSTALLING, USING, OR SERVICING THIS EQUIPMENT. IF YOU HAVE ANY DOUBTS ABOUT HOW TO USE THIS EQUIPMENT SAFELY, CONTACT THE GRANVILLE-PHILLIPS PRODUCT MANAGER FOR THIS EQUIPMENT AT THE ADDRESS LISTED IN THIS MANUAL.

### Explosive Gases

Do not use the gauge tube when there is danger of explosion from ignition of combustible gas mixtures. The sensing element normally operates at only 125 °C but it is possible that momentary transients or controller malfunction can raise the sensor above the ignition temperature of combustible mixtures, which might then explode, causing damage to equipment and injury to personnel.

### Limitation of Use of Compression Mounts

Do not use a compression mount (quick connect) for attaching the gauge tube to the system in applications resulting in positive pressures in the gauge tube. Positive pressures might blow the tube out of a compression fitting and damage equipment and injure personnel. The Convector gauge should not be used above 1000 Torr (1333 mbar or  $1.33 \times 10^5$  Pa).

### Tube Mounting Position

If the gauge tube will be used to measure pressures greater than 1 Torr or 1 mbar, the tube must be mounted with its axis horizontal. Although the gauge tube will read correctly below 1 Torr when mounted in any position, erroneous readings will result at pressures above 1 Torr if the tube axis is not horizontal. Erroneous readings can result in over or underpressure conditions which may damage equipment and injure personnel.

### Overpressure

Convector gauges should not be used above 1000 Torr true pressure. **Do not use above 1000 Torr true pressure.** The VGC is furnished calibrated for N<sub>2</sub>. It will also measure the pressure of air correctly within the accuracy of the instrument. Do not attempt to use a Convector gauge calibrated for N<sub>2</sub> to measure or control the pressure of other gases such as argon or CO<sub>2</sub>, unless accurate conversion data for N<sub>2</sub> to the other gas is properly used. If accurate conversion data is not used or improperly used, a potential overpressure explosion hazard can be created under certain conditions.

For example, at 760 Torr of argon gas pressure, the indicated pressure on a Convector gauge calibrated for N<sub>2</sub> is 24 Torr. At an indicated pressure of 50 Torr, the true pressure of argon is considerably above atmospheric pressure. Thus, if the indicated pressure is not accurately converted to true pressure, it is possible to overpressure your system. Overpressure may cause glassware, such as ionization gauges, to shatter dangerously, and if high enough may cause

metal parts to rupture, thus damaging the system and possibly injuring personnel. See Section 5.3 for proper use of conversion data.

A pressure relief valve should be installed in the system should the possibility of exceeding 1000 Torr exist.

### High Indicated Pressure

For some gases, be aware the indicated pressure will be higher than the true pressure. For example, at a true pressure of 9 Torr for helium the indicated pressure on a Convector gauge calibrated for N<sub>2</sub> is 760 Torr. The safe way to operate the gauge is to properly use accurate conversion data. See Section 5.3 for proper use of conversion data.

### Chemical

Cleaning solvents, such as trichloroethylene, perchloroethylene, toluene and acetone, produce fumes that are toxic and/or flammable. Use only in areas well ventilated to the outdoors and away from electronic equipment, open flames, or other potential ignition sources.

### Sensor Failure

If the gauge tube becomes disconnected from the controller or if the sensor wire in the gauge tube fails, the controller will indicate 9.9+9. If the tube is unplugged from a powered controller, there may be an instantaneous (0 to 0.2 seconds) drop in the pressure indication and the process control relay could activate for this brief time, depending on the order in which the tube pins break contact.

### Tube Contamination

**The calibration of the gauge will be seriously affected by any gas which will attack the gold plated sensor, and could result in overpressurizing the system. Two primary gases in this category are mercury vapor and fluorine.**

## 5.1 INTRODUCTION

The Convector gauge (CG) Module provides pressure measurement from  $1.0 \times 10^{-3}$  Torr ( $1.3 \times 10^{-3}$  mbar or  $1.3 \times 10^{-1}$  Pa) to 1000 Torr, and one meaningful digit pressure indication down to  $1 \times 10^{-4}$  Torr, air equivalent.

Analog output is also provided.

## 5.2 INSTALLATION

### Units of Measure

Your instrument will have been shipped from the factory pre-set to display the units of measure, Torr, millibar, or Pa, that you requested. If you wish to change units, proceed as follows:

1. Shut off power to the control unit.
2. Remove the top cover. Locate the Convector Module.
3. Locate [16] the millibar and [17] Pa units switches.
4. Leave both switches open for Torr units. Close the appropriate switch for either millibar or Pa units.
5. Modify the units of measure of the electrometer to be consistent with the Convector.
6. Slip the label card out of the top of the front panel and apply the appropriate pressure units label.

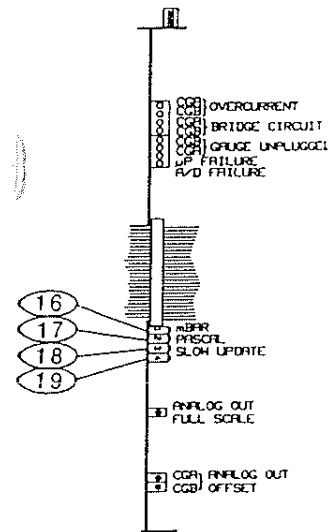

Fig. 5.1 Convector Module Top View

#### Display Update Rate Switch [18]

When "ON", this switch enables pressure averaging. The display will be updated approximately every 3 seconds. When "OFF", the update period is approximately 0.5 seconds.

#### Not used [19]

#### Convector Gauge Tube Installation

##### Important Precautions for Gauge Tube Installation

The following precautions in the use and installation of the Convector gauge tube must be observed.

#### **IMPORTANT**

1. Observe the precautions at the front of this chapter regarding tube mounting position and high pressure operation.
2. It is recommended that the gauge tube be installed with the port oriented vertically downward to ensure that no system condensates or other liquids collect in the gauge tube. It is not necessary, however, from a performance standpoint.
3. Keep the tube clean. **Do not** remove the mounting port cover until you are ready to install the tube.
4. **Do not** mount the gauge tube in a manner such that deposition of process vapors upon the internal surfaces of the tube may occur through line-of-sight access to the interior of the gauge tube.

5. **Do not** install the tube where high amplitudes of vibration are present. Excessive vibration will cause forced convection at high pressure giving erroneous readings.
6. **Do not** bake the tube to temperatures above 150 °C.
7. **Do not** install the gauge tubes where they will be exposed to corrosive gases such as mercury vapor, chlorine, or fluorine, which will attack the gold plated sensor.
8. For greatest accuracy and repeatability the gauge tube should be located in a stable room temperature environment.

### Gauge Tube Orientation

It is important to consider the orientation of the gauge tube if accurate readings above 1 Torr are desired.

Below 1 Torr: The gauge tube will operate and accurately read pressures below 1 Torr when mounted in any orientation. Above 1 Torr: The gauge tube will accurately read pressures above 1 Torr only when mounted with its axis horizontal, preferably with the port pointing vertically downward, as shown in Fig. 5.2. It is valuable to point the port downward to facilitate the removal of condensation and other contaminants.

Furthermore, the gauge is factory calibrated with the port pointing vertically downward. Installation of the gauge with the port in other orientations may affect the accuracy of the indicated pressure.

Mounting clearance dimensions are shown in Fig. 5.2.

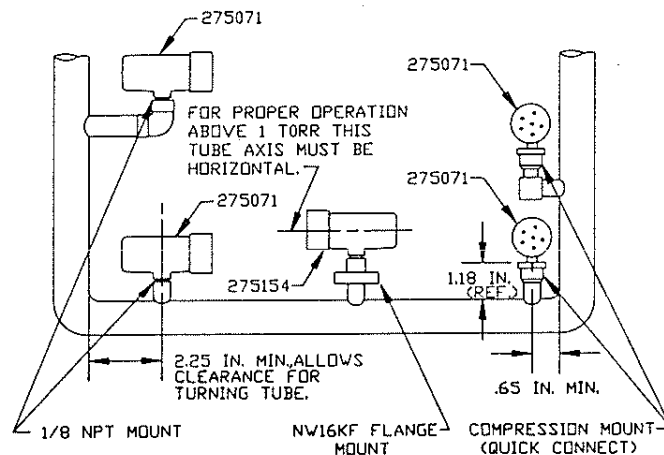

Fig. 5.2 Convectron Gauge Mounting

#### 1. Compression Mount (Quick Connect)

Do not use for positive pressure applications.

The gauge tube port is designed to fit a standard 1/2 in. compression (quick connect) mount such as the Cajon® Ultra-Torr® fittings.

Remove the caplug from the gauge tube port, insert the gauge tube port into the compression fitting and finger tighten the press ring. If a seal is not achieved it may be due to extreme cleanliness of the O-ring. A light film of vacuum grease such as Apiezon<sup>1</sup> will ensure sealing and is normally preferable to the use of pliers or pipe wrench to further tighten the press ring. You may point the electrical pins of the gauge tube anywhere you wish in a 360 degree horizontal circle for optimum routing of the gauge tube cable.

2. 1/8 NPT Mount

The threads on the gauge tube port will fit a standard 1/8 NPT female fitting. Wrap the threads of the gauge tube port with Teflon<sup>®</sup> tape and screw these threads into the system fitting hand tight. Do not use any wrench or tool. The gauge tube body functions adequately as its own wrench. Tighten only sufficiently to achieve a seal. After this, one-half turn additional tightening is all that can be gained without over-stressing the tube port.

3. NW10, 16, 25 and 40KF Flange Mount

The KF mounting system requires an O-ring and centering ring to be placed between the mating flanges. The flanges are then held together with the aluminum flange clamp by tightening the wing nut. Maximum pressure for this style mounting system is 1000 Torr absolute.

### 5.3 OPERATION

#### Reading Pressure

#### WARNING

**IF USED WITHOUT PROPER CALIBRATION OR WITHOUT REFERENCE TO PROPER CALIBRATION TABLES**, Convectron gauges can supply misleading pressure indications. This may result in dangerous overpressure conditions within the system. As supplied from the factory, the controller is designed to read pressure for nitrogen. For use with any other gases, consult the gas type correction charts found later in this manual.

The Convectron pressures are read in displays A and B of the control unit. These pressures are displayed to 2 digits, except in the  $10^{-4}$  Torr range, where only 1 meaningful digit is displayed.

#### Special Considerations For Use Below $10^{-3}$ Torr

During a fast pumpdown from atmosphere, thermal effects will prevent the Convectron from

---

<sup>1</sup>Trademark of James G. Biddle Co.

tracking pressure rapidly below  $10^{-3}$  Torr. After about 15 minutes readings in the  $10^{-4}$  range will be valid and response will be rapid. Calibration at vacuum may be performed at this time, or sooner if readings in the  $10^{-4}$  range are not needed.

The  $10^{-4}$  Torr range is accurate to about 0.1 milli Torr provided the instrument has been carefully zeroed at vacuum. See Section 5.4 for vacuum and atmosphere calibration procedures. For accurate use in the  $10^{-4}$  Torr range, zeroing should be repeated frequently. Pressure readings in the  $10^{-4}$  Torr range may differ from those found from ion gauges, since ion gauges usually lose sensitivity near their upper pressure limits.

#### Use With Gases Other Than N<sub>2</sub> and Air

Before using the Convector gauge to measure the pressure of other gases make certain the ATM adjustment is correctly set for air. See Section 5.4.

It is important to understand that the indicated pressure on a Convector gauge depends on the type of gas in the tube, and on the orientation of the tube axis as well as on the gas pressure in the tube. Convector gauges are supplied calibrated for N<sub>2</sub> within the accuracy of the instrument. With certain safety precautions, the Convector gauge may be used to measure pressure of other gases.

Convector gauge tubes are thermal conductivity gauges of the Pirani type. These gauges transduce gas pressure by measuring the heat loss from a heated sensor wire maintained at constant temperature. For gases other than N<sub>2</sub> and air the heat loss is different at any given true pressure and thus the indicated reading will be different.

#### Indicated vs. True Pressure Curves

Figures 5.3, 5.4, 5.5, 5.6, 5.7 and 5.8 show the true pressure vs. indicated pressure on Series 350 instruments for eleven commonly used gases. The following list will help to locate the proper graph for a specific application:

<u>Fig.</u>	<u>Range and Units</u>	<u>Gases</u>
5.3	1 to 100 mTorr	All
5.4	0.1 to 1000 Torr	Ar, CO <sub>2</sub> , CH <sub>4</sub> , Freon 12, He
5.5	0.1 to 1000 Torr	D <sub>2</sub> , Freon 22, Kr, Ne, O <sub>2</sub>
5.6	$10^{-3}$ to $10^{-1}$ mbar	All
5.7	0.1 to 1000 mbar	Ar, CO <sub>2</sub> , CH <sub>4</sub> , Freon 12, He
5.8	0.1 to 1000 mbar	D <sub>2</sub> , Freon 22, Kr, Ne, O <sub>2</sub>

Note that 1 mbar = 100 Pa, so the mbar charts may be used for pascal units by multiplying the values on the axes by 100.

A useful interpretation of these curves is, for example, that at a true pressure of  $2 \times 10^{-2}$  Torr of CH<sub>4</sub> the heat loss from the sensor is the same as at a pressure of  $3 \times 10^{-2}$  Torr of N<sub>2</sub> (see Fig. 5.3). The curves at higher pressure vary widely from gas to gas because the thermal losses at higher pressures are greatly different for different gases.

The Convector gauge tube utilizes convection cooling to provide resolution superior to any other thermal conductivity gauge near atmospheric pressure of N<sub>2</sub> and air. Because convection effects are geometry dependent, the true pressure vs indicated pressure curves for the Convector gauge tube are likely to be much different from curves for heat loss tubes made by others. Therefore, it is not safe to attempt to use calibration curves supplied by other manufacturers for their gauges with the Convector nor is it safe to use curves for the Convector gauge with gauges supplied by other manufacturers.

If you must measure the pressure of gases other than N<sub>2</sub> or air, use Figures 5.3 through 5.8 to determine the maximum safe indicated pressure for the other gas as explained below.

**EXAMPLE 1** Maximum safe indicated pressure.

Assume a certain system will withstand an internal pressure of 2000 Torr or 38.7 psia. For safety you wish to limit the maximum internal pressure to 760 Torr during backfilling. Assume you wish to measure the pressure of argon. On Fig. 3.4 locate 760 Torr on the left hand scale, travel to the right to the intersection with the argon (Ar) curve and then down to an indicated pressure of 24 Torr (N<sub>2</sub> equivalent). Thus in this hypothetical situation the maximum safe indicated pressure for argon is 24 Torr.

For safety, it is prudent to place a warning label on the instrument face which, under the assumed conditions, would read "DO NOT EXCEED 24 TORR FOR ARGON."

**EXAMPLE 2** Indicated to true pressure conversion.

Assume you wish to determine the true pressure of argon in a system when the Convector is indicating 10 Torr. On Fig. 5.4, read up from 10 Torr (N<sub>2</sub> equivalent) indicated pressure to the argon curve and then horizontally to the left to a true pressure of 250 Torr. Thus 250 Torr argon pressure produces an indication of 10 Torr, (N<sub>2</sub> equivalent).

**EXAMPLE 3** True to indicated pressure conversion.

Assume you wish to set a process control set point at a true pressure of 20 Torr of CO<sub>2</sub>. On Fig. 5.4, locate 20 Torr on the true pressure scale, travel horizontally to the right to the CO<sub>2</sub> curve and then down to an indicated pressure of 6 Torr (N<sub>2</sub> equivalent). Thus the correct process control setting for 20 Torr of CO<sub>2</sub> is 6 Torr (N<sub>2</sub> equivalent).

**EXAMPLE 4** True to indicated pressure conversion.

Assume you wish to obtain a helium pressure of 100 Torr in the system. On Fig. 5.4, locate 100 Torr on the left hand scale, travel horizontally to the right to attempt to intersect the He curve. Because the intersection is off scale it is apparent that this true pressure measurement requirement for helium exceeds the capability of the instrument.

For gases other than those listed, the user must provide accurate conversion data for safe operation. The Convector gauge is not intended for use above 1000 Torr true pressure.



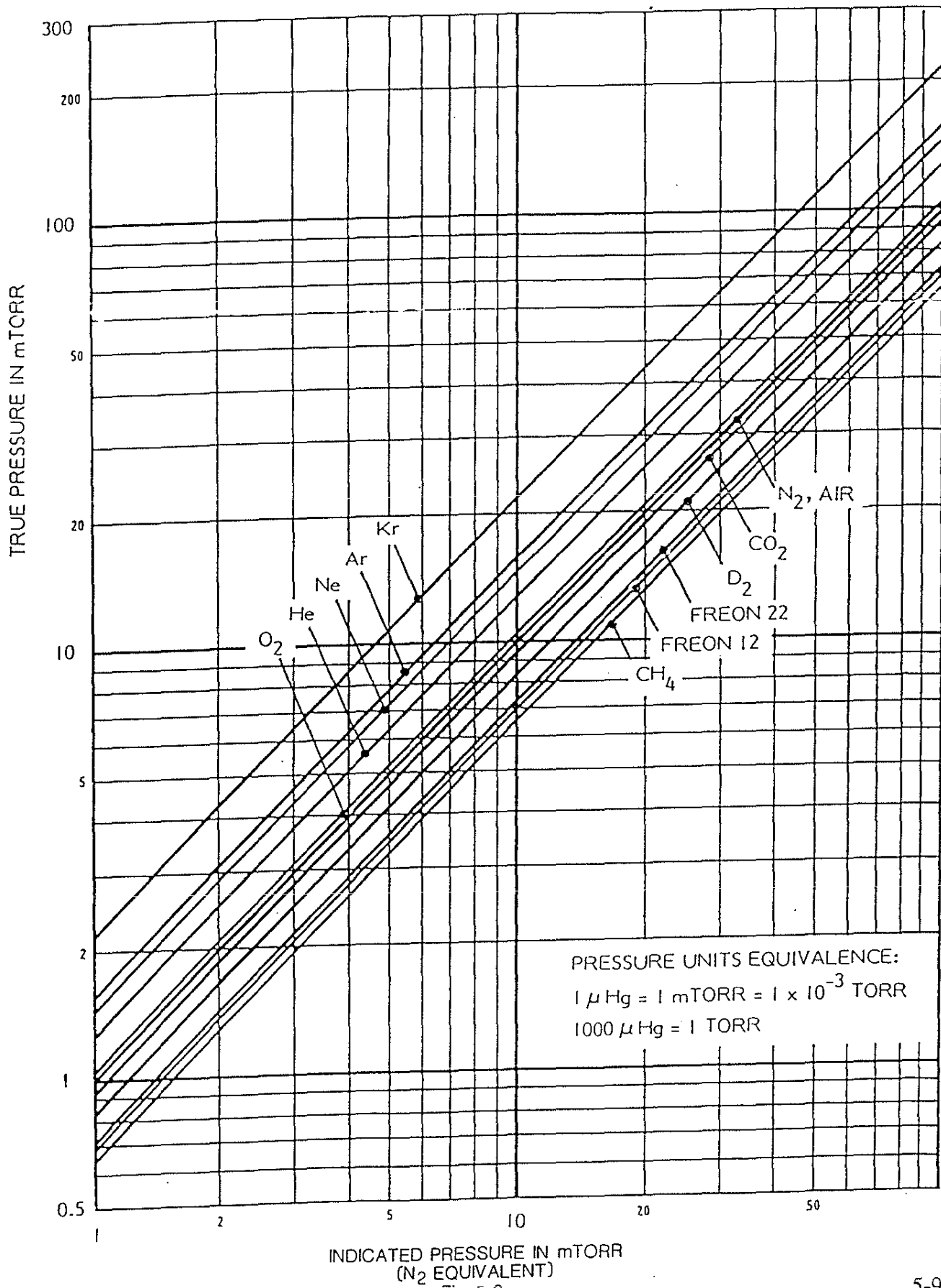

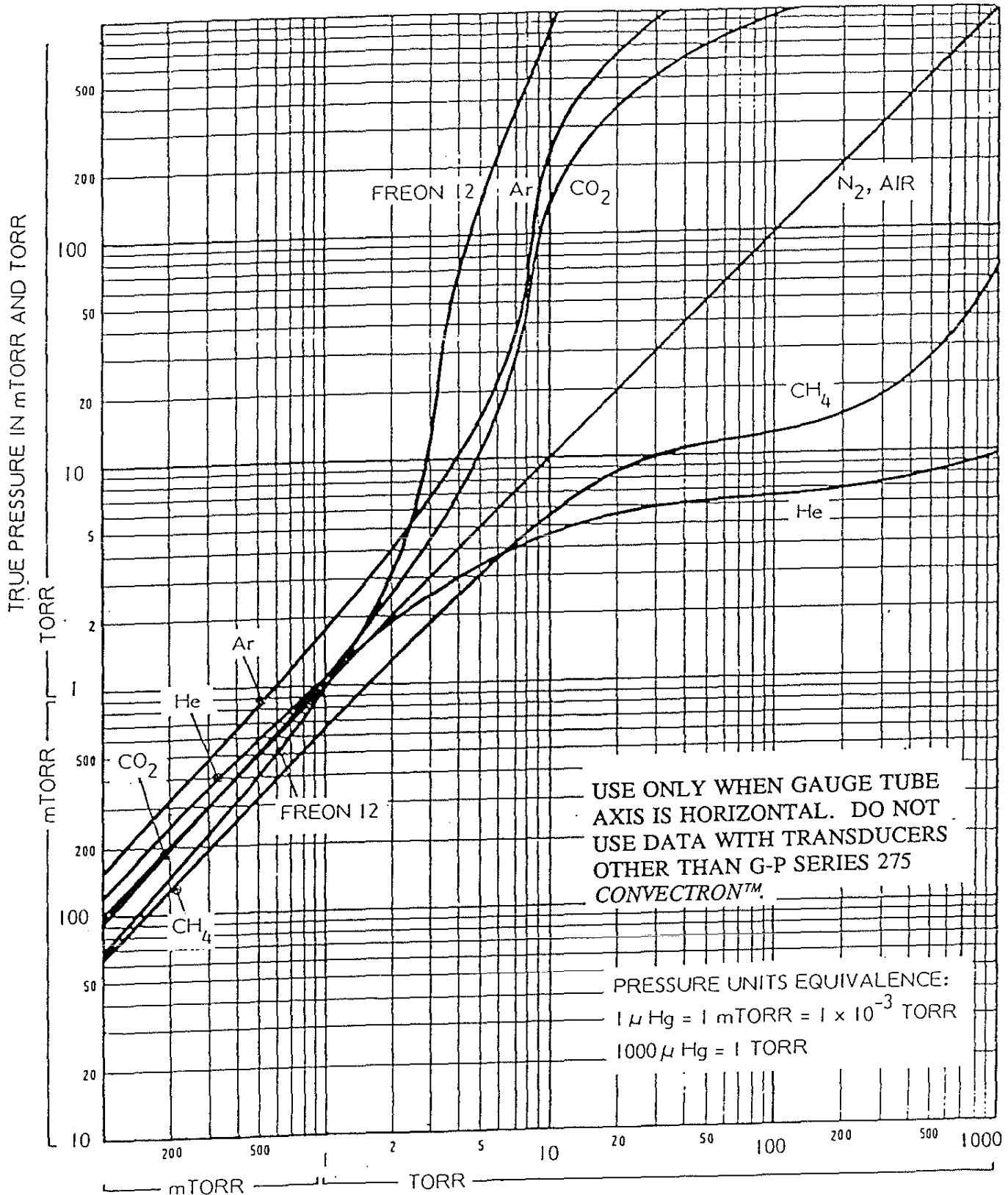

INDICATED PRESSURE IN mTORR AND TORR (N<sub>2</sub> EQUIVALENT)

Fig. 5.4

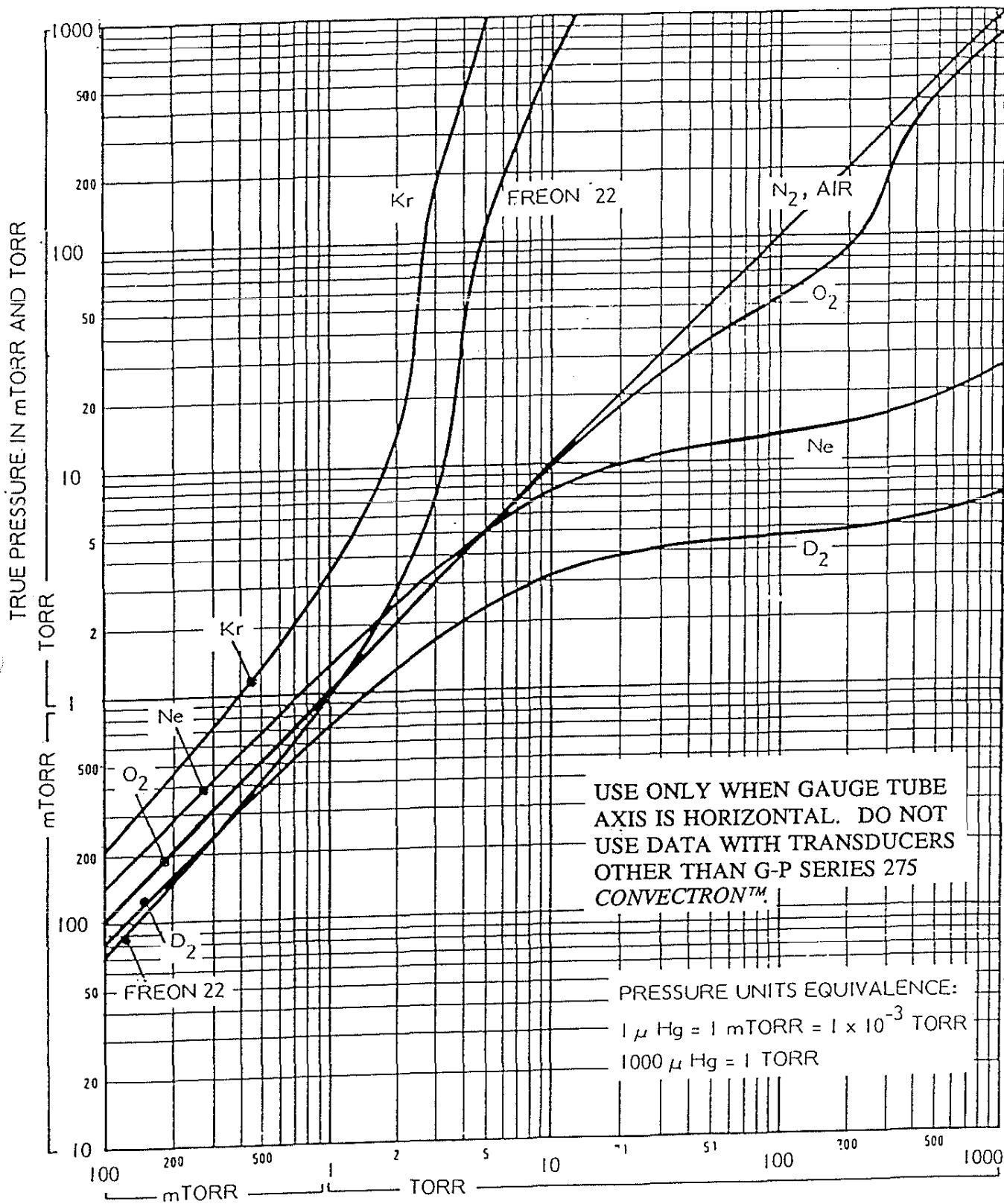

INDICATED PRESSURE IN mTORR AND TORR  
 (N<sub>2</sub> EQUIVALENT)

Fig. 5.5

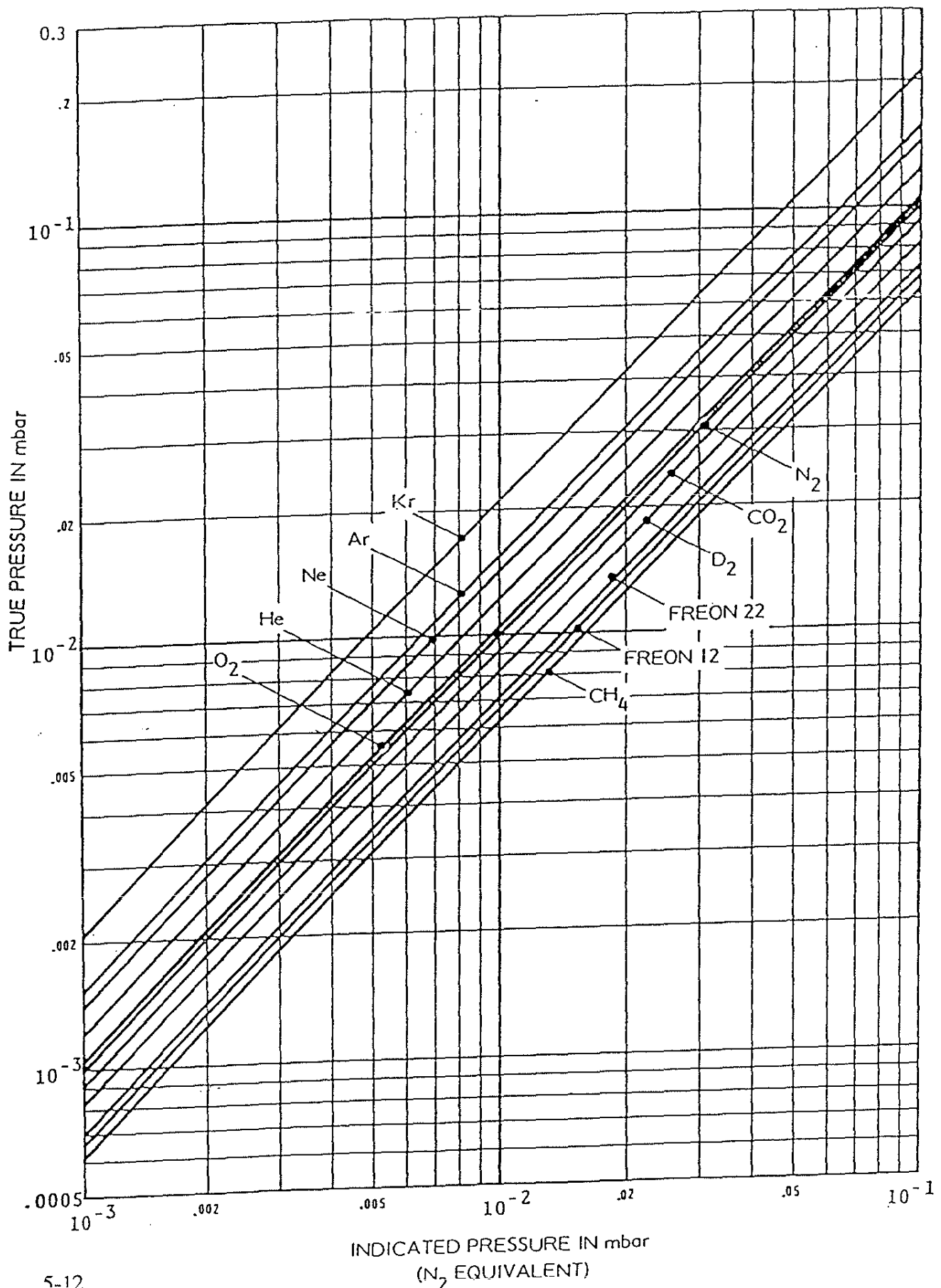

INDICATED PRESSURE IN mbar  
(N<sub>2</sub> EQUIVALENT)  
Fig. 5.6

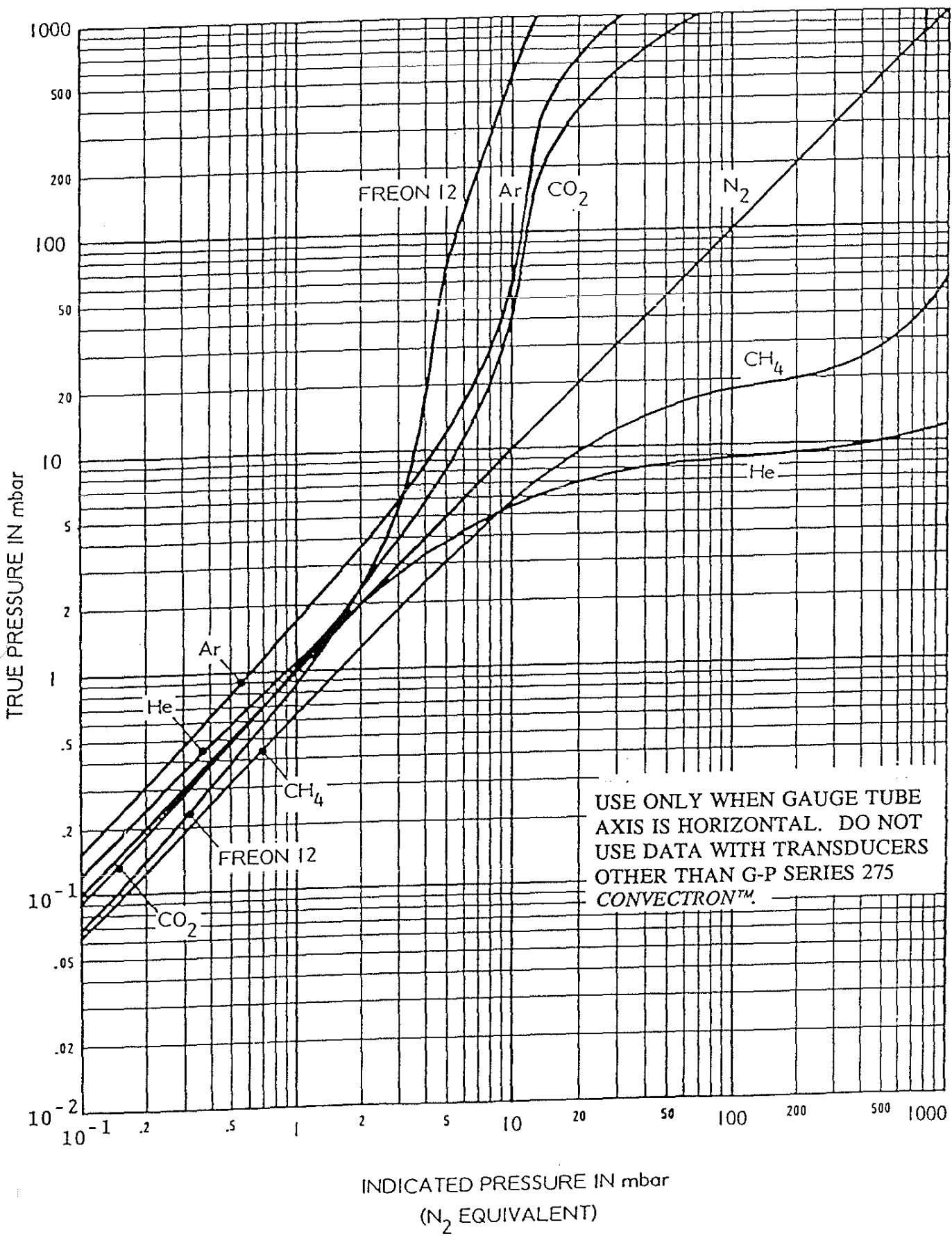
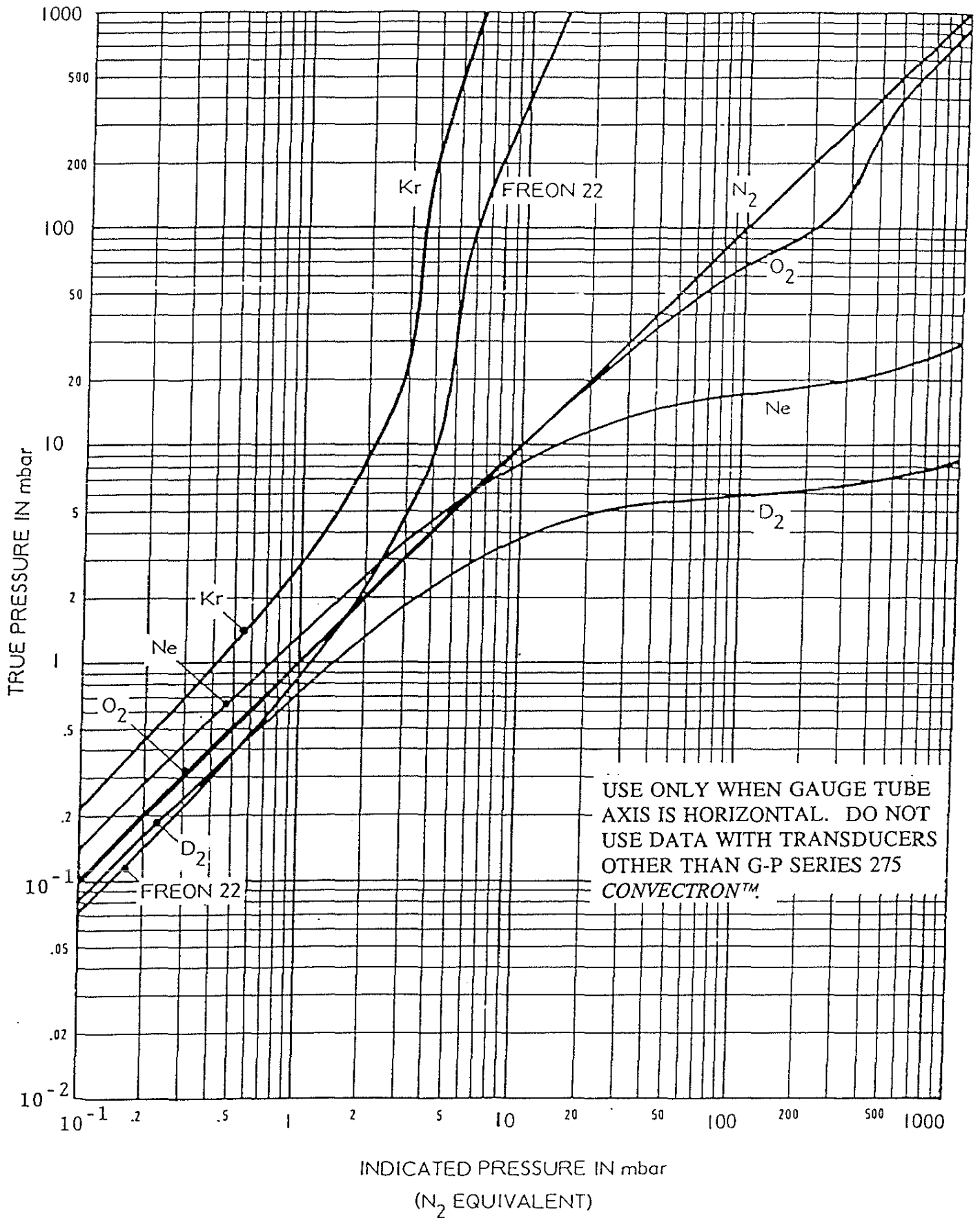

Fig. 5.7



## Analog Output

On the rear panel are provided analog outputs for both gauges, see Refs. [20] and [21]. These are dc voltages proportional to the logarithm of the pressure, scaled to 1 volt per decade: -7 volts =  $1 \times 10^{-4}$  or less, Torr or mbar, -6 volt =  $1 \times 10^{-3}$ , etc.

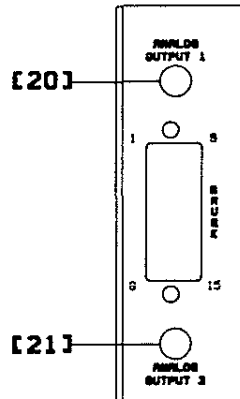

Fig. 5.9 Convectron Module Rear Panel

Internal offset adjustments are provided which allow a shift in the analog output at  $10^{-4}$  Torr away from 0 volts to anywhere in the range -7 to +1 Vdc. This adjustment does not affect the slope of the analog output vs pressure curve. See Section 5.4 for adjustment.

Standard 1/8" miniature phone jack connectors are provided for the analog output.

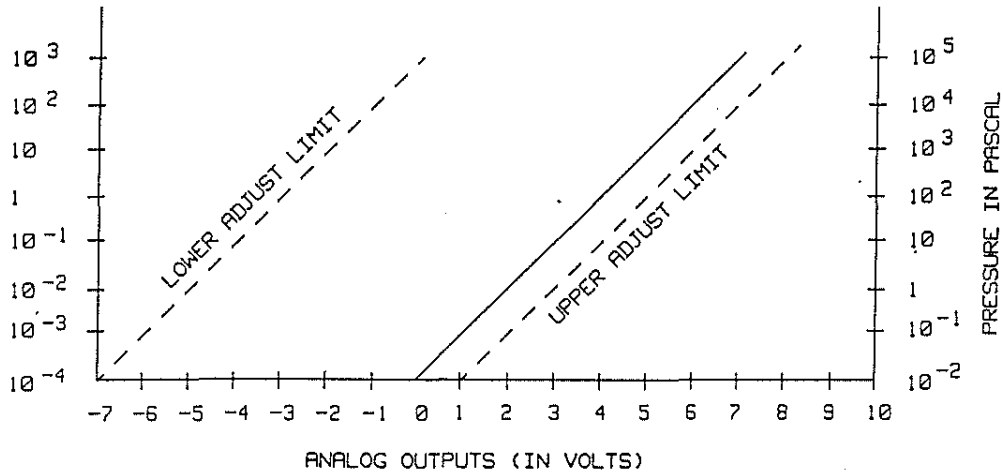

Fig. 5.10 Convectron Gauge Pressure Analog Output

## 5.4 CALIBRATION

Each gauge tube is individually calibrated for  $N_2$  and air prior to leaving the factory. The Convectron gauge tube itself has a temperature compensated design. Each controller is also individually calibrated to provide accurate readout of  $N_2$  and air pressure with any calibrated tube. Therefore, initial calibration should not be necessary. See Section 5.3 for use with gases other than  $N_2$  or air.

Calibration should be performed if accurate readings in the  $10^{-4}$  Torr range are desired, if the tube becomes contaminated, does not read correctly, or to readjust for use with long cables.

The gauge and controller can be calibrated as a system by performing the following steps:

[27] - Analog Output Full Scale Adjustment

This potentiometer may be adjusted to calibrate the span of the analog output voltage to the factory setting of 1 volt per decade. This adjustment is common to both outputs.

[28] and [29] - Analog Output Offset; Gauges A and B

These potentiometers provide adjustable offset voltages to each analog output. The range of this adjustment allows setting the analog output at vacuum ( $P = 1 \times 10^{-4}$  Torr) anywhere in the range -7 to +1 Vdc.

The factory calibration is established by adjusting [28] and [29] to yield -7 volt outputs when both gauges are at vacuum (pressure less than  $1 \times 10^{-4}$  Torr), then adjusting [27] to increase 1 volt for each decade the pressure increases.

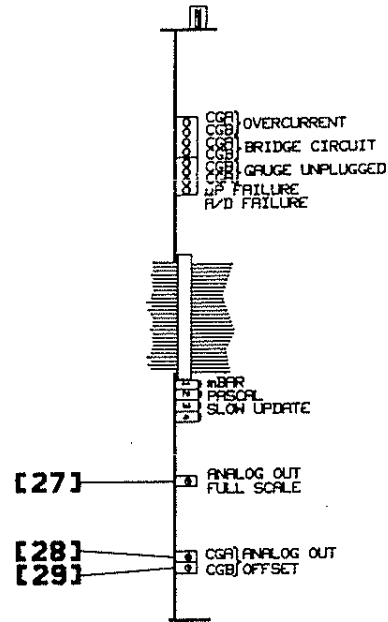

Fig. 5.11 Convectron Module Top View

Zero Adjustment [23] and [26]

1. Evacuate the system to a pressure less than  $1 \times 10^{-4}$  Torr.
2. With the gauge tube operating, adjust the VAC pot until a single "0" shows in the display. Note that if the adjustment is turned too far below zero, a minus sign will appear in the display. Thus, proper zero calibration is achieved when only the "0" appears.

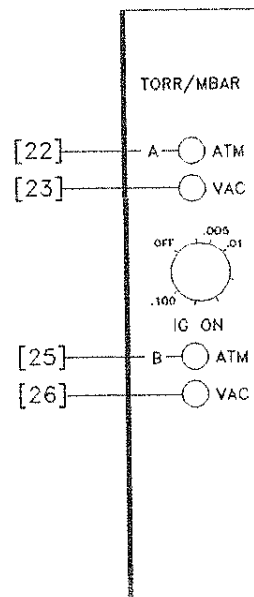

Fig. 5.12 Convectron Module Front Panel



Atmosphere Adjustment [22] and [25]

1. Allow the system pressure to rise to atmospheric pressure of N<sub>2</sub> or air.
2. Adjust the ATM pot until the pressure displayed agrees with the absolute pressure as read on an accurate barometer. Use absolute pressure, not corrected to sea level.

**NOTE:** 1 atmosphere normal at sea level =  $7.6 \times 10^{+2}$  Torr =  $1.0 \times 10^{+3}$  mbar =  $1.0 \times 10^{+5}$  Pa.

# NOTES

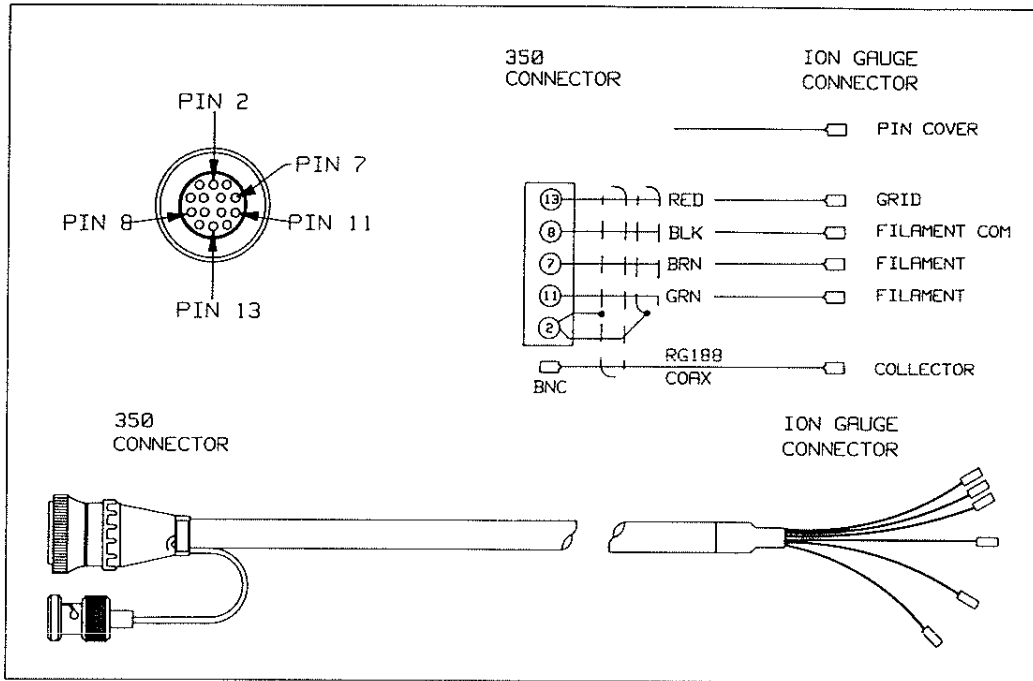

Fig. A.1 Nude Ion Gauge Cable, 50 FT. Length Maximum

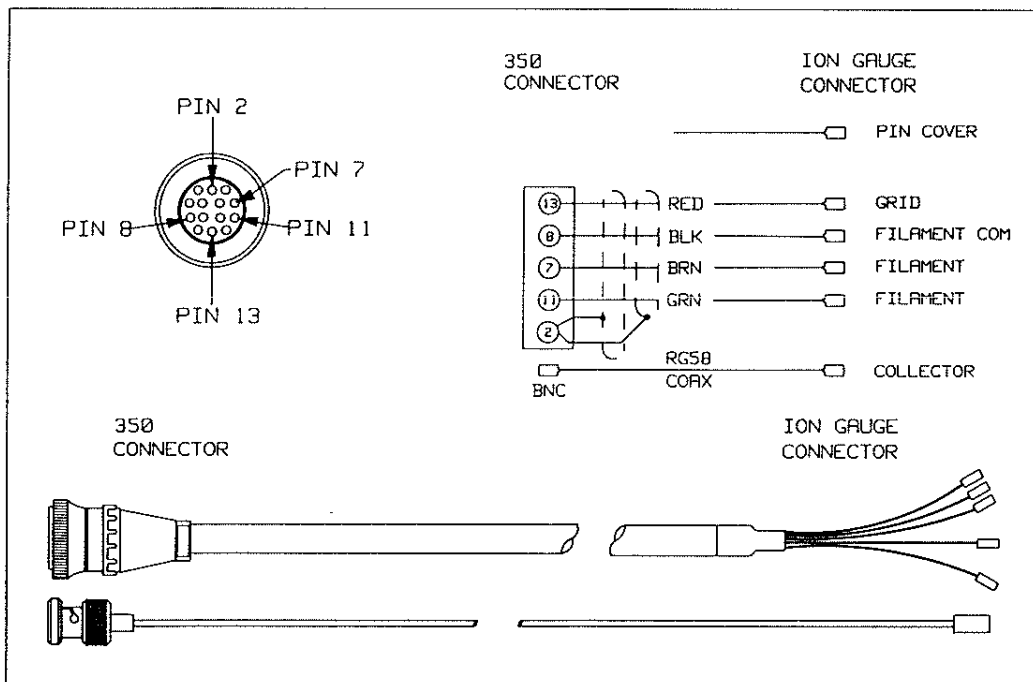

Fig. A.2 Nude Ion Gauge Cable Set, 51-100 FT. Length Maximum