

Instruction Manual



EH Mechanical Booster Pumps

Ideal
vacuum products
(505) 872-0037

 **BOC EDWARDS**

Declaration of Conformity

We, BOC Edwards,
Manor Royal,
Crawley,
West Sussex RH10 2LW, UK

declare under our sole responsibility that the product(s)

EH250 Safe Area Pumps	A301-51-935, A301-53-935, A301-52-936, A301-54-936
EH500A Safe Area Pumps	A302-71-935, A302-73-935, A302-72-396, A302-74-936
EH1200 Safe Area Pumps	A305-90-935, A305-92-935, A305-91-936, A305-93-936
EH1200C Flameproof Pumps	A305-55-900, A305-56-982
EH2600 7.5 kW Safe Area Pumps	A307-51-935, A307-53-935, A307-52-936, A307-54-936
EH2600 11 kW Safe Area Pumps	A307-51-946, A307-52-982
EH2600C Flameproof Pumps	A307-55-900, A307-56-982
EH4200 7.5 kW Safe Area Pumps	A309-51-935, A309-53-935, A309-52-936, A309-54-936
EH4200 11 kW Safe Area Pumps	A309-51-946, A309-52-982
EH4200C Flameproof Pumps	A309-55-900, A309-56-982

to which this declaration relates is in conformity with the following standard(s)
or other normative document(s)

BS 4999 Part 145 : 1987	General Requirements for Rotating Electrical Machines.
EN 50014 *	Electrical Apparatus for Potentially Explosive Atmospheres. Part 1 : General Requirements.
EN 50018 *	Electrical Apparatus for Potentially Explosive Atmospheres. Part 5 : Flameproof Enclosure 'd'.

following the provisions of

98/37/EC	Machinery Safety Directive.
89/336/EEC	Electromagnetic Compatibility Directive.
73/023/EEC	Low Voltage Directive.
79/196/EEC *	Electrical Apparatus for Use in Potentially Explosive Atmospheres Directive.

* Only applicable to the flameproof motors on EH1200C, EH2600C and EH4200C pumps.

Dr. S. E. Ormrod, Technical Director, BOCE Equipment Operations

Date and Place

CONTENTS

Section	Title	Page
1	INTRODUCTION	1
1.1	Scope and definitions	1
1.2	Description	1
1.3	General construction	2
1.4	'C' model chemical EH pumps	2
1.4.1	Flameproof motors	2
1.4.2	Coupling-cover purge	2
1.4.3	After-cooler	2
1.5	Principle of operation	3
1.6	Hydrokinetic fluid-coupling	3
2	TECHNICAL DATA	6
2.1	General	6
2.2	Performance	15
2.3	Recommended backing pumps	15
2.4	Connections	15
2.4.1	Vacuum connections	15
2.4.2	Cooling-water connections	15
2.4.3	Coupling-cover purge connection (EH1200C/2600C/4200C only)	15
2.5	Electrical data	16
2.6	Coupling-cover purge nitrogen supply (EH1200C/2600C/4200C only)	16
2.7	Noise and vibration data	17
2.8	Item Numbers	17
3	INSTALLATION	18
3.1	Safety	18
3.2	System requirements	18
3.3	Unpack and inspect	19
3.4	Fill the pump with oil	20
3.4.1	Coupling-cover	20
3.4.2	Shaft-seal reservoir	20
3.4.3	Gear-cover (EH1200, EH2600 and EH4200 pumps only)	22
3.5	Cooling-water connections (EH1200, EH2600 and EH4200 pumps only)	22
3.6	Electrical connections	22
3.6.1	Electrical supply configuration	22
3.6.2	Motor connections	23
3.7	Check the direction of pump rotation	27
3.8	Connect the coupling-cover purge nitrogen supply EH1200C/2600C/4200C only)	28
3.9	Connect the pump-inlet and outlet	28
3.10	External evacuation of coupling-cover (optional)	29
4	OPERATION	30
4.1	Operational safety	30

Section	Title	Page
4.2	Start-up procedure	30
4.2.1	Pre-start checks	30
4.2.2	Start-up	30
4.3	Shut-down	31
5	MAINTENANCE	32
5.1	Safety	32
5.2	Maintenance plan	33
5.3	Check the oil-levels	33
5.4	Inspect the pump connections	34
5.5	Change the pump oil	34
5.6	Lubricate the rear-bearing (EH250 and EH500A pumps only)	35
6	STORAGE AND DISPOSAL	37
6.1	Storage	37
6.2	Disposal	37
7	SERVICE AND SPARES	38
7.1	Introduction	38
7.2	Service	38
7.3	Spares	38

RETURN OF BOC EDWARDS EQUIPMENT

Tables

Table	Title	Page
1	Lubrication capacities (litres)	6
2	Full load current ratings	16
3	Item Numbers	17
4	Electrical supply connection configurations	23
5	Maintenance plan	23

Illustrations

Figure	Title	Page
1	EH250/500A Mechanical Booster Pumps (part cut-away)	4
2	EH1200/2600/4200 Mechanical Booster Pumps (part cut-away)	5
3	EH250 dimensions (mm)	7
4	EH500A dimensions (mm)	7
5	EH1200 dimensions (mm)	8
6	EH1200C dimensions (mm)	9
7	EH2600/4200 (7.5 kW) dimensions (mm)	10
8	EH2600 (11 kW) dimensions (mm)	11
9	EH2600C dimensions (mm)	12
10	EH4200 (11 kW) dimensions (mm)	13
11	EH4200C dimensions (mm)	14
12	Sight-glasses	21
13	Electrical supply connection: EH250/500A/1200/2600/4200: 220 to 240 V, 50 Hz	24
14	Electrical supply connection: EH250/500A/1200/2600/4200: 380 to 415 V, 50 Hz	24
15	Electrical supply connection: EH250/500A: 208 to 230 V, 60 Hz	25
16	Electrical supply connection: EH250/500A/1200/2600/4200: 460 V, 60 Hz	25
17	Electrical supply connection: EH1200/2600/4200: 208 to 230 V, 60 Hz	26
18	Lubricate the rear bearing (EH250/500A pumps only)	36

Associated publications

Publication title	Publication Number
Vacuum pump and vacuum system safety	P300-20-000

(This page deliberately left blank)

1 INTRODUCTION

1.1 Scope and definitions

This manual provides installation, operation and maintenance instructions for the BOC Edwards EH250, EH500A, EH1200, EH2600 and EH4200 (safe area) Mechanical Booster Pumps, and the EH1200C, EH2600C and EH4200C (chemical) Mechanical Booster Pumps. All of the pumps are abbreviated to EH pumps in the remainder of this manual. You must use your EH pump as specified in this manual.

Read this manual before you install and operate your EH pump. Important safety information is highlighted as WARNING and CAUTION instructions; you must obey these instructions. The use of WARNINGS and CAUTIONS is defined below.

WARNING

Warnings are given where failure to observe the instruction could result in injury or death to people.

CAUTION

Cautions are given where failure to observe the instruction could result in damage to the equipment, associated equipment and process.

The units used throughout this manual conform to the SI international system of units of measurement.

1.2 Description

The EH pumps are compact and have high pumping speeds. You must use the EH pump with a suitable backing pump. The EH pumps can operate with a maximum continuous inlet pressure of 1000 mbar. You can achieve low system pressures by the use of two or more EH pumps in series.

The EH pump coupling-cover is connected to the pump outlet and forms an integral part of the vacuum system. The connecting lines have a filter which removes debris and so prevents contamination of the lubricating oil and bearings. For an even cleaner system, you can evacuate the coupling-cover and bearings by connection to the pump-inlet or to an external vacuum pump.

The hydrocarbon safe area and chemical EH pumps use hydrocarbon oils, such as Ultragrade 20. Versions of the safe area pumps for use with PFPE (perfluoropolyether) oils are also available for vacuum systems in which oxygen or other reactive or corrosive gases are pumped.

All the EH pumps have ISO inlet-flange and outlet-flange connections.

1.3 General construction

The EH pumps are positive displacement Roots vacuum pumps. The pump mechanism is driven by a three-phase electric motor through a hydrokinetic fluid-coupling.

The EH250, EH500A, EH1200, EH2600 and EH4200 pumps are all fitted with safe area motors. The EH1200C, EH2600C and EH4200C pumps are all fitted with flameproof motors (see Section 1.4.1). All of the motors are air-cooled.

The pump shafts and rotors are made of high-grade, corrosion-resistant, cast-iron. The internal and external shaft-seals are made of polytetrafluoroethylene (PTFE) or fluoroelastomer.

The pump-bearings, gears and seals are lubricated by oil fed from reservoirs in the coupling-cover. A series of seals stops the oil from reaching the vacuum side of the pump. The coupling-cover is evacuated. You can inspect the oil-levels through sight-glasses which are fitted to the coupling-cover. Oil-filler, oil-drainage and external evacuation connections are provided on the cover.

The timing gears on the EH1200, EH1200C, EH2600, EH2600C, EH4200 and EH4200C pumps are lubricated by oil inside the gear-cover. An oil-filler connection is provided and you can inspect the oil-level through a sight-glass fitted to the gear-cover.

1.4 'C' model chemical EH pumps

1.4.1 Flameproof motors

The EH1200C, EH2600C and EH4200C chemical pumps are all fitted with flameproof motors:

- Pumps suitable for 50 Hz operation are fitted with a flameproof motor approved to EEx d, Gas Group IIA, IIB, Temperature Class T4.
- Pumps suitable for 60 Hz operation are fitted with a flameproof motor approved to CSA, Division 1 area, Gas Class I Group C & D, and Dust Class II Group F & G, Temperature Class T3C.

1.4.2 Coupling-cover purge

A pipeline connector is provided on the coupling-cover of the EH1200C, EH2600C and EH4200C pumps. You can connect a suitable purge gas supply to this connector, to provide for coupling-cover purge with nitrogen at positive pressure. This will purge the shaft-seals, and prevent the entry of corrosive or toxic vapours into the coupling-cover and gear-cover.

A fixed restrictor in the connector ensures that the correct amount of nitrogen is allowed to flow into the coupling-cover.

1.4.3 After-cooler

The EH1200C, EH2600C and EH4200C chemical pumps have an after-cooler in the pump outlet. On the EH2600C and EH4200C pumps, this after-cooler is resistant to corrosive vapours which may condense on it during pump operation (depending on the application).

1.5 Principle of operation

The EH pump is shown in Figures 1 and 2. The motor-shaft drives one of the rotors through the fluid-coupling. The 1:1 gears inside the coupling-cover drive the second rotor in the opposite direction inside the stator housing. A small, accurately gauged, clearance is maintained between the rotors and between each rotor and the stator wall. This clearance allows the pump to operate at high speed without mechanical wear and without the need for lubrication inside the swept volume.

1.6 Hydrokinetic fluid-coupling

The hydrokinetic fluid-coupling connects the electric-motor shaft to the rotor. This system is configured so that when the gas-load is high, the rotational speed of the rotors is reduced. As the gas-load decreases, the rotors accelerate to full speed. This allows continuous operation of the pump over the vacuum range without the risk of overloading the motor and removes the need for bypass-valves and associated pipelines.

The fluid-coupling is viscosity sensitive. The two versions of the EH pump (for hydrocarbon and PFPE oils) have fluid-coupling drives which are specifically designed for the type of oil used in the pump.

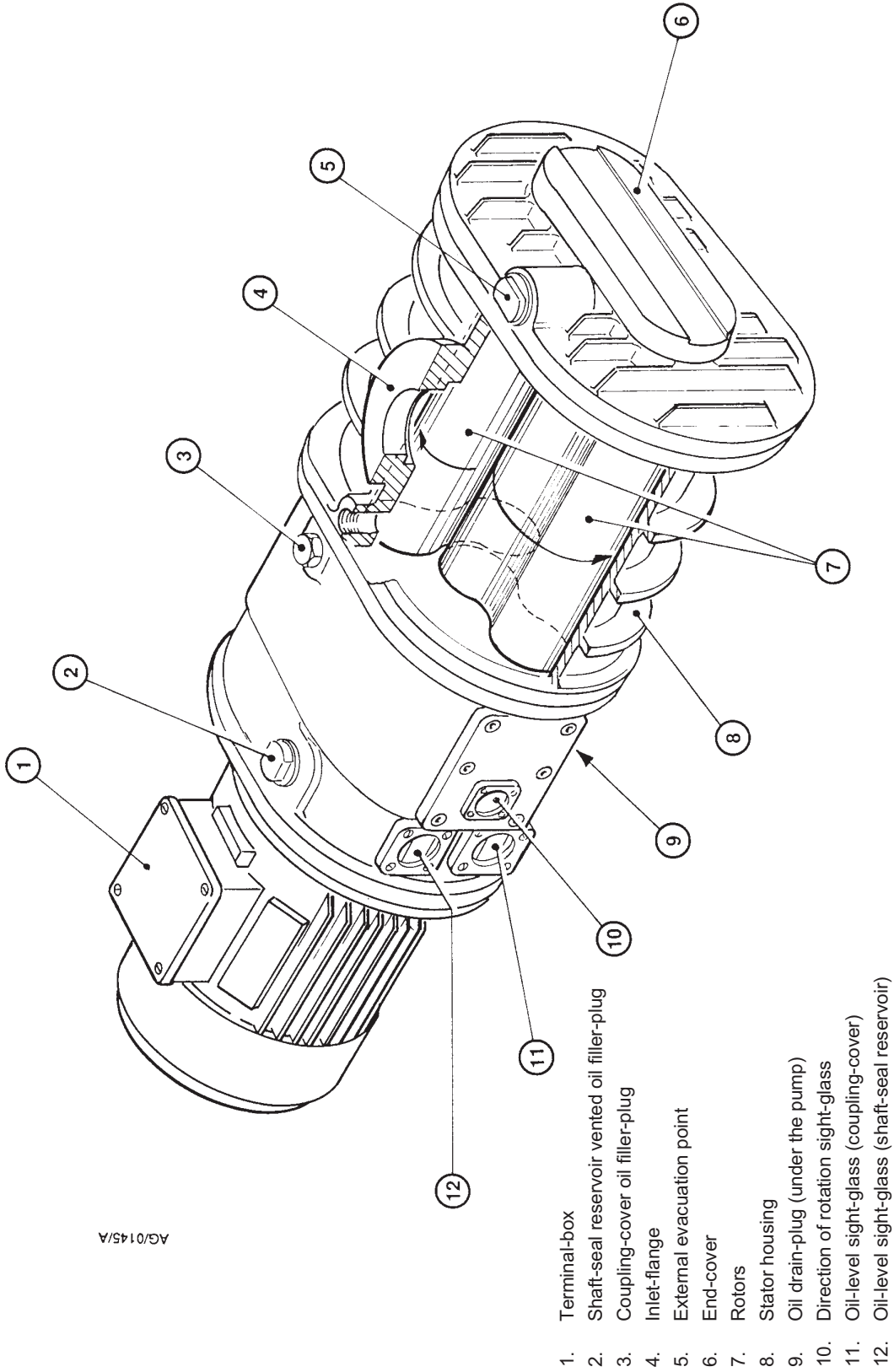
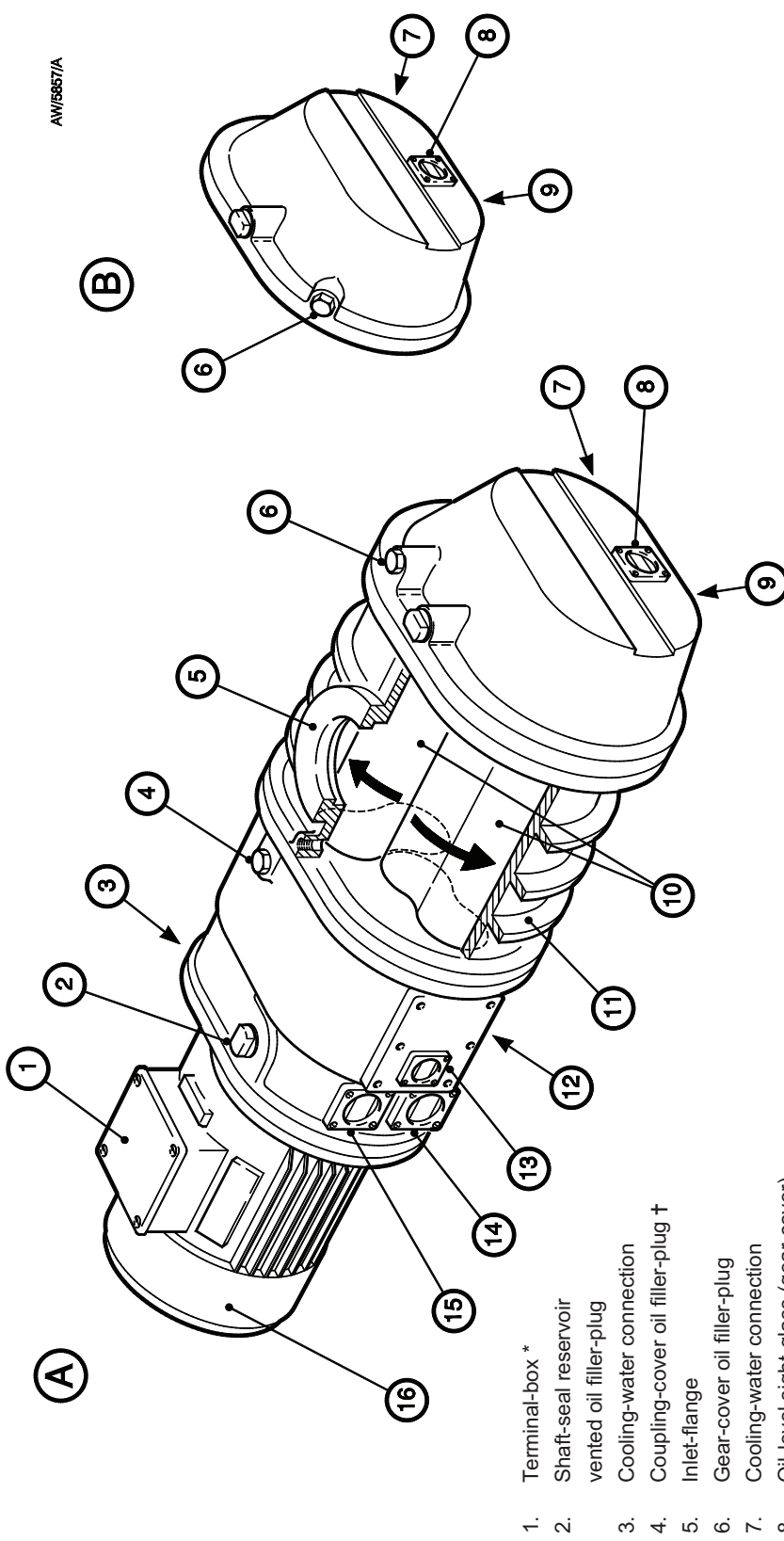

Figure 1 - EH250/500A Mechanical Booster Pumps (part cut-away)



AW/6657/A

1. Terminal-box *
2. Shaft-seal reservoir vented oil filler-plug
3. Cooling-water connection
4. Coupling-cover oil filler-plug †
5. Inlet-flange
6. Gear-cover oil filler-plug
7. Cooling-water connection
8. Oil-level sight-glass (gear-cover)
9. Gear-cover oil drain-plug (under the pump)
10. Rotors
11. Stator housing
12. Coupling-cover oil drain-plug (under the pump)
13. Direction of rotation sight-glass (EH1200 only)
14. Oil-level sight-glass (coupling-cover)
15. Oil-level sight-glass (shaft-seal reservoir)
16. Motor fan cover

* EH1200/2600/4200 shown. On the 'C' model pumps, the terminal-box is on the side of the pump-motor

† EH1200/2600/4200 pumps only. On the 'C' model pumps, this is a combined coupling-cover oil filler-plug and purge connector

- A EH2600(C) & EH4200(C) pumps
- B EH1200(C) pump (detail)

Figure 2 - EH1200(C)/2600(C)/4200(C) Mechanical Booster Pumps (part cut-away)

2 TECHNICAL DATA

2.1 General

Overall dimensions	See Figures 3 to 11			
Mass				
EH250	61 kg	EH2600, 7.5 kW	308 kg	
EH500A	74 kg	EH2600, 11 kW	345 kg	
EH1200	149 kg	EH2600C	415 kg	
EH1200C	170 kg	EH4200, 7.5 kW	380 kg	
		EH4200, 11 kW	415 kg	
		EH4200C	485 kg	
Ambient operating temperature range	5 to 40 °C (see Note 1 below)			
Storage temperature range	-10 to 80 °C			
Maximum operating humidity	90% RH			
Protection degree (as defined by IEC 529)	IP44			
Recommended cooling-water flow (with inlet temperature of 20 °C)				
EH1200/EH1200C	120 lh ⁻¹ (see Note 2 below)			
EH2600/EH2600C	250 lh ⁻¹			
EH4200/EH4200C	250 lh ⁻¹			
Recommended cooling-water supply pressure	2 to 6 bar gauge (3 to 7 bar absolute, 3 x 10 ⁵ to 7 x 10 ⁵ Pa)			
Recommended oil type				
Hydrocarbon pumps	Ultragrade 20 (see Note 3 below)			
PFPE pumps	Fomblin YVAC 16/6 (see Note 3 below)			
Recommended grease type (for use with EH250/EH500A pumps)	Fomblin RT15 (see Note 3 below)			
Oil capacity	See Table 1 below			

	EH250	EH500A	EH1200/ EH1200C	EH2600/ EH2600C	EH4200/ EH4200C
Gear-cover	-	-	1.25	3.5	3.5
Coupling-cover	1.5	1.5	2.4	6.5	6.5
Shaft-seal reservoir	0.125	0.125	0.125	1.5	1.5

Table 1 - Lubrication capacities (litres)

Note 1: For operation outside this temperature range contact BOC Edwards for advice. Between -30 °C and 5 °C, special precautions must be taken.

Note 2: You can operate the EH1200/EH1200C continuously without cooling-water if the inlet pressure is kept below 5 mbar (5 x 10² Pa) and the pumpdown time is no longer than 10 minutes.

Note 3: BOC Edwards Material Safety Data Sheets for the above oils and grease are available on request.

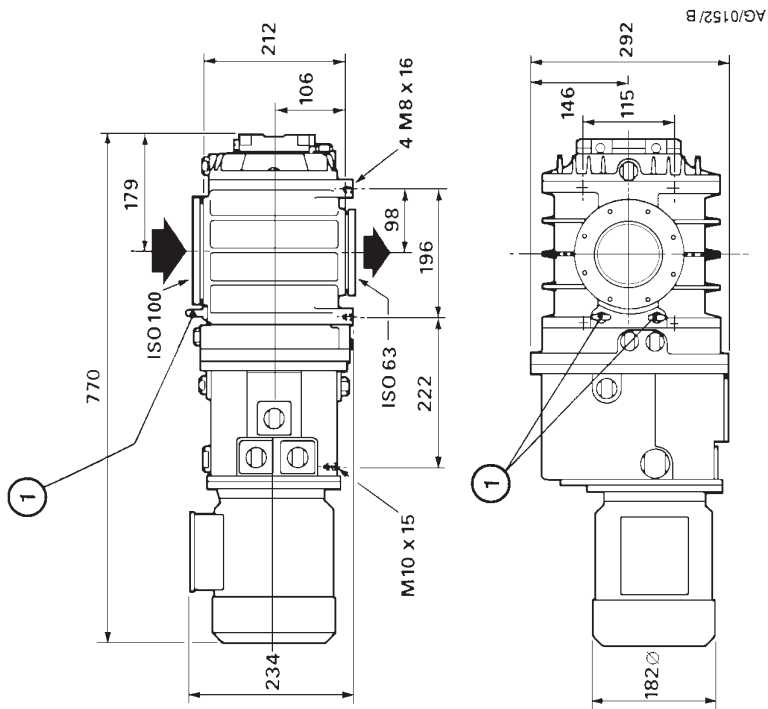

AG/0152/B

1. Lifting point

Figure 4 - EH500A dimensions (mm)

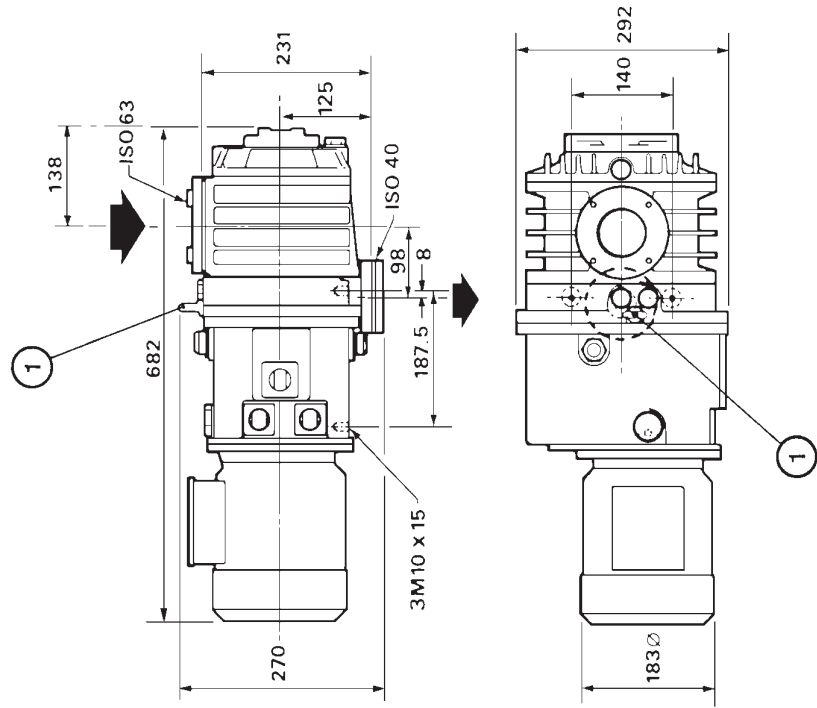

AG/0147/B

1. Lifting point

Figure 3 - EH250 dimensions (mm)

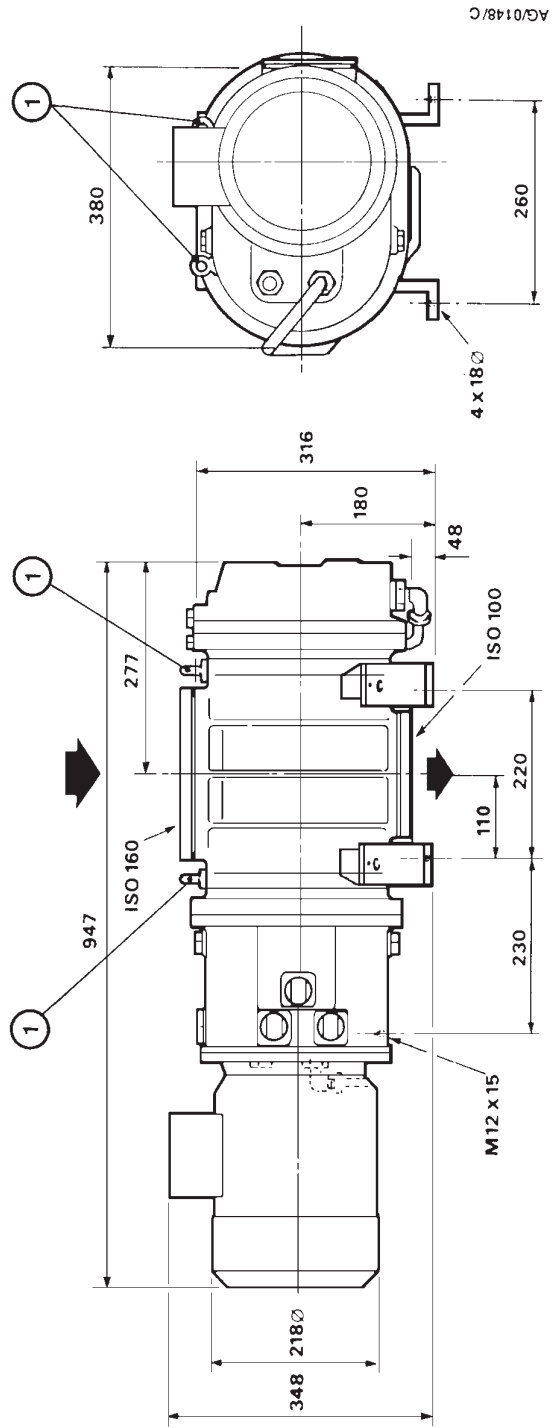
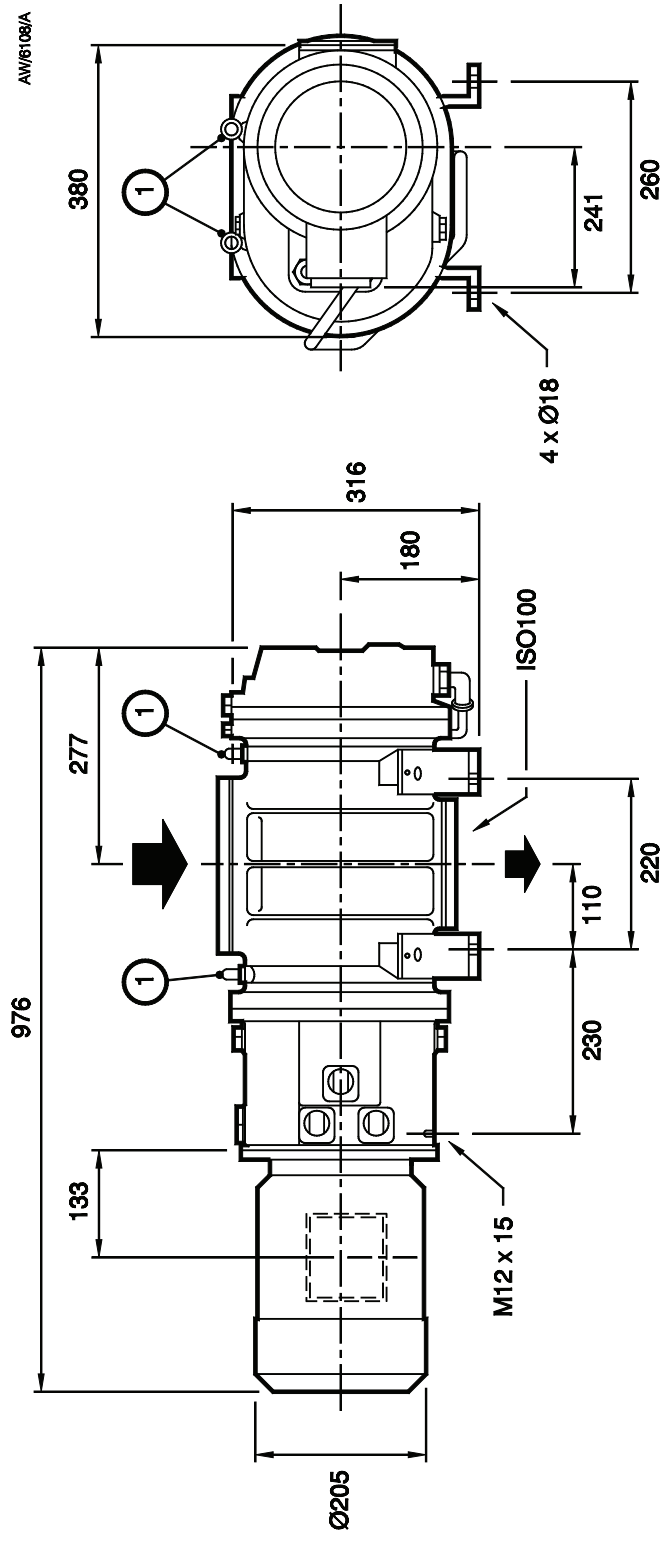

Figure 5 - EH1200 dimensions (mm)

1. Lifting point



1. Lifting point

Figure 6 - EH1200C dimensions (mm)

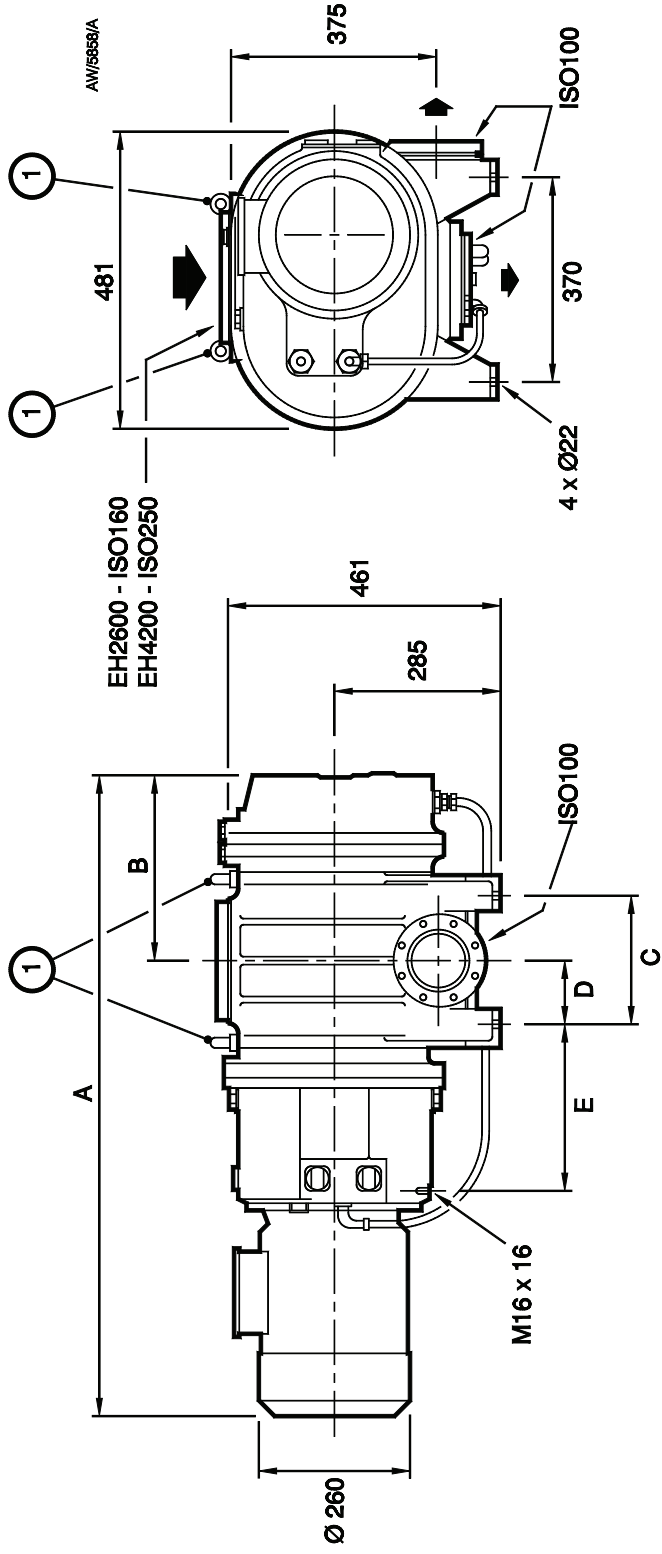

	A	B	C	D	E
EH2600	1093	312	220	110	275
EH4200	1273	402	370	185	290

1. Lifting point

Figure 7 - EH2600 (7.5 kW) / 4200 (7.5 kW) dimensions (mm)

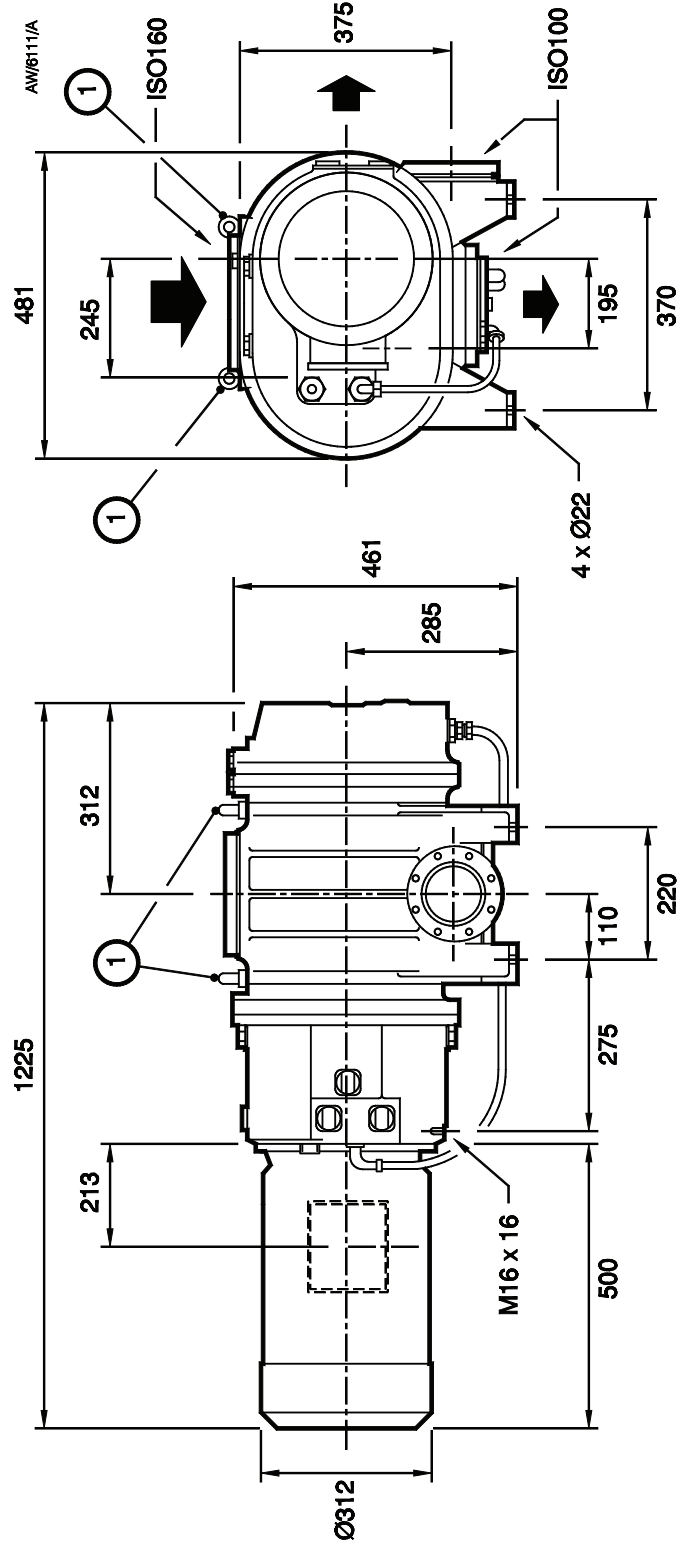

1. Lifting point

Figure 8 - EH2600 (11 kW) dimensions (mm)

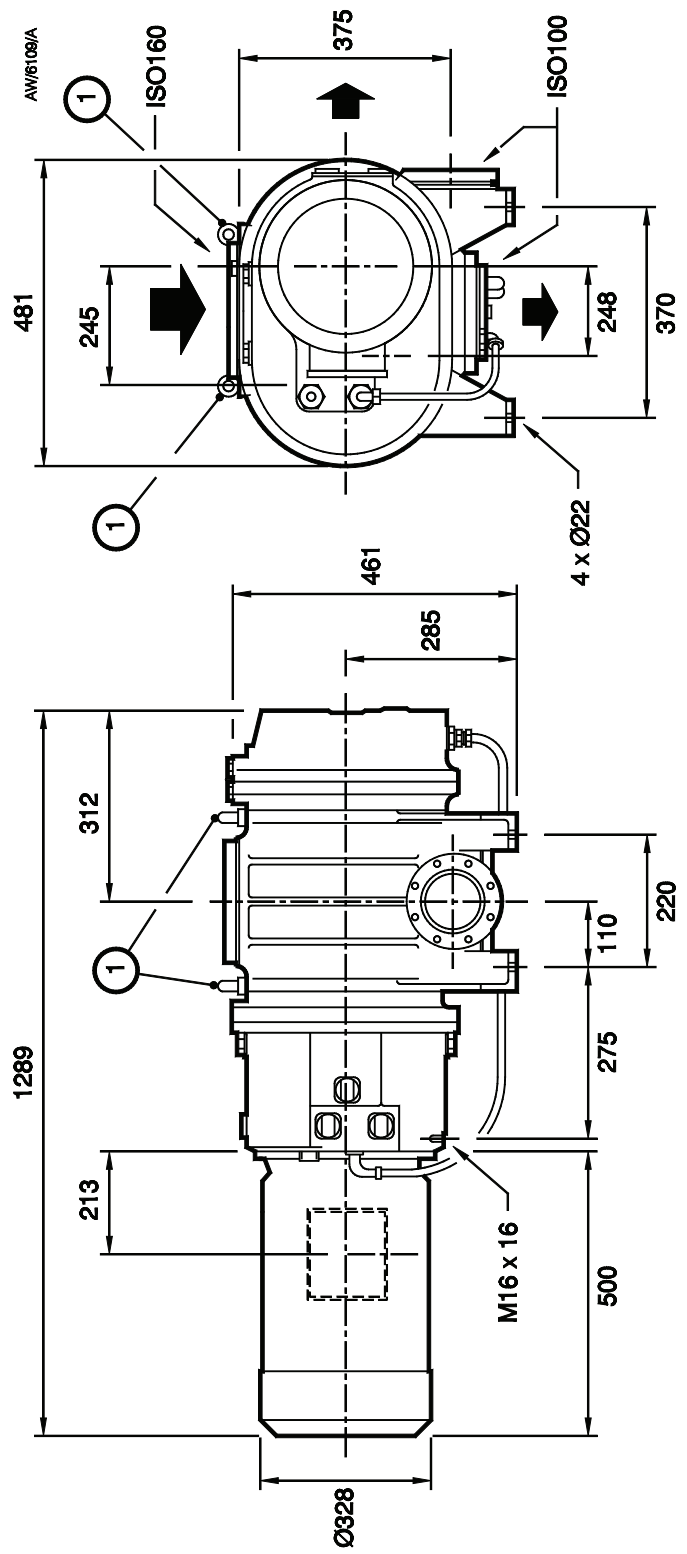

1. Lifting point

Figure 9 - EH2600C dimensions (mm)

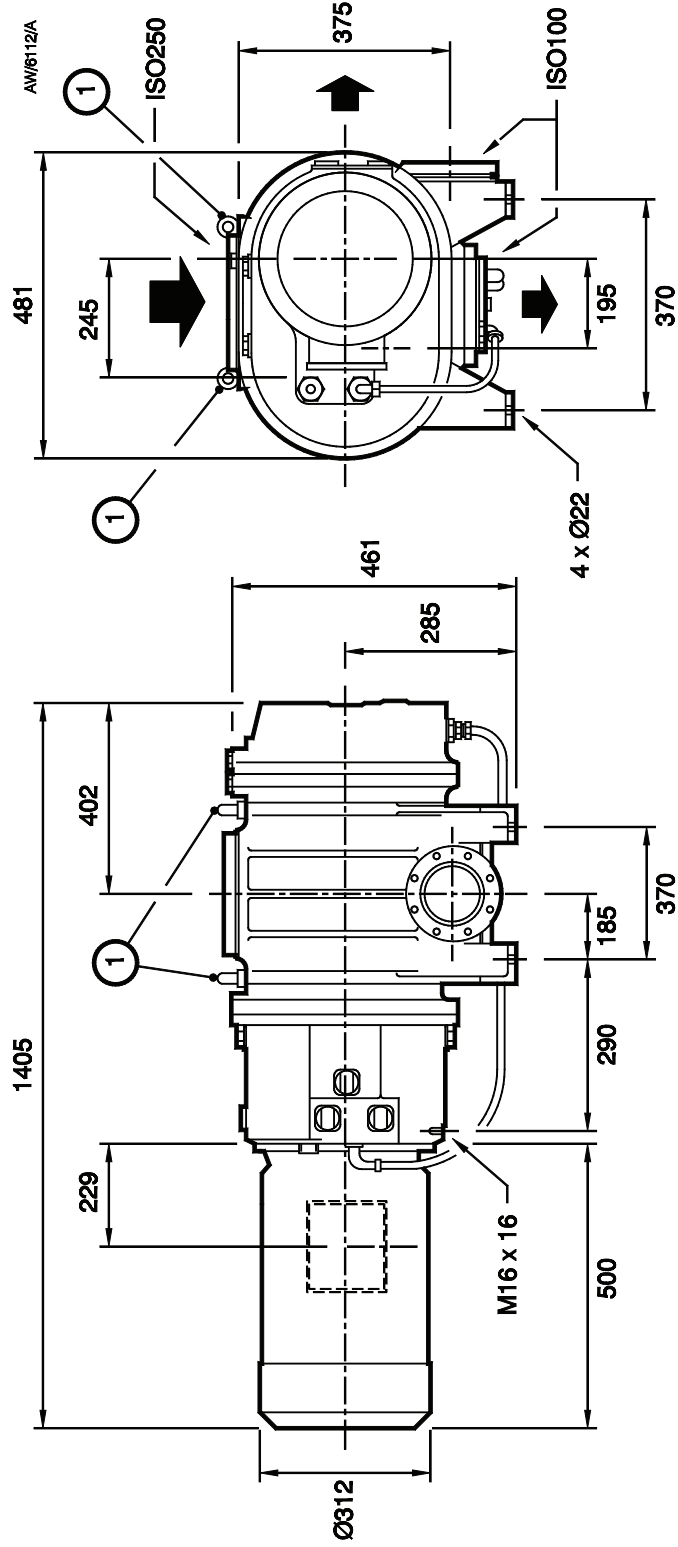

1. Lifting point

Figure 10 - EH4200 (11 kW) dimensions (mm)

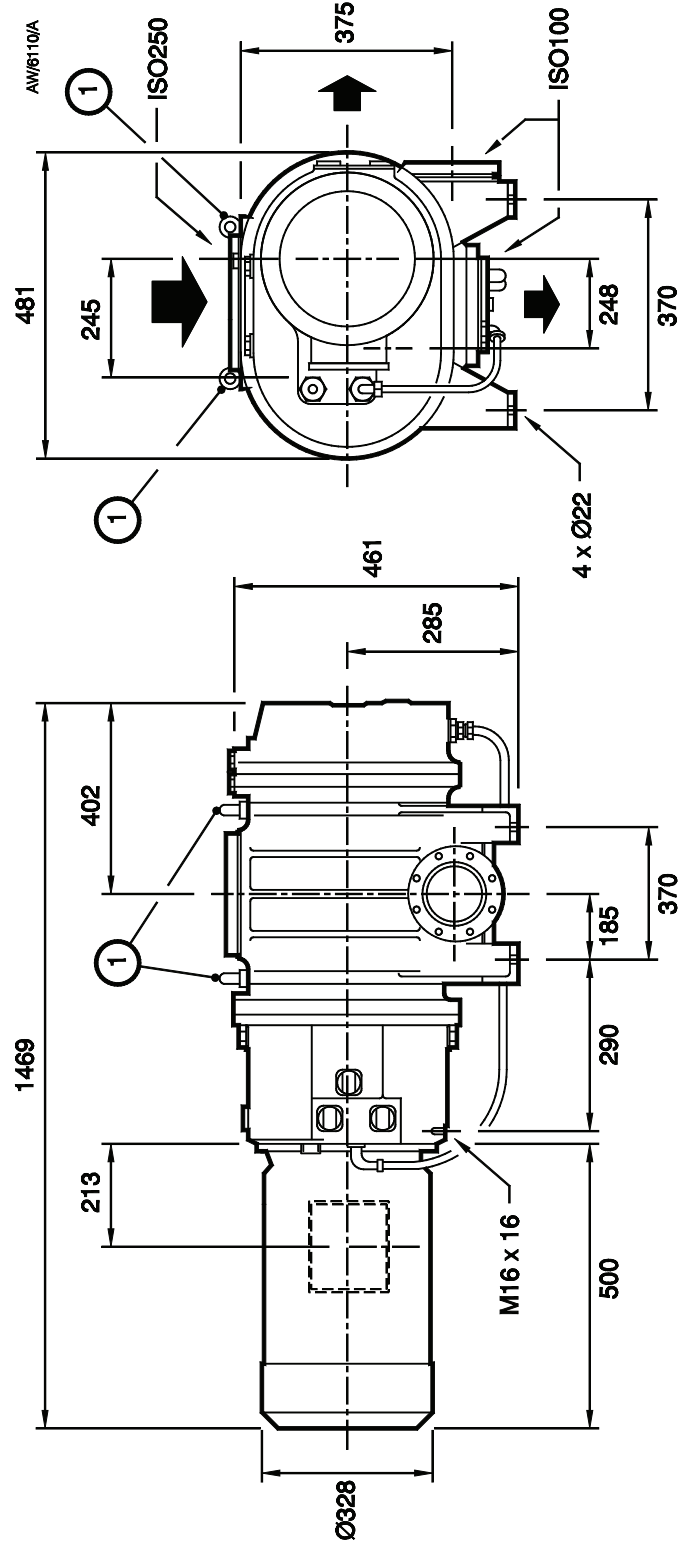

1. Lifting point

Figure 11 - EH4200C dimensions (mm)

2.2 Performance

Rotational speed (50 Hz supply)	0 to 2900 r.min ⁻¹
Rotational speed (60 Hz supply)	0 to 3500 r.min ⁻¹
Total pressure (single-stage backing pump, with gas-ballast)	2 x 10 ⁻² mbar absolute (2 Pa)
Ultimate pressure (single-stage backing pump without gas-ballast, permanent gases)	2 x 10 ⁻³ mbar absolute (2 x 10 ⁻¹ Pa)
Total pressure (two-stage backing pump with gas-ballast)	1 x 10 ⁻³ mbar absolute (1 x 10 ⁻¹ Pa)
Maximum outlet pressure (see Section 1.2.4)	1000 mbar absolute (1 x 10 ⁵ Pa)
Pressure differential across pump (determined by the hydrokinetic drive)	

Pump	50 Hz		60 Hz	
EH250	0 to 180 mbar	0 to 1.8 x 10 ⁴ Pa	0 to 150 mbar	0 to 1.5 x 10 ⁴ Pa
EH500A	0 to 110 mbar	0 to 1.1 x 10 ⁴ Pa	0 to 90 mbar	0 to 0.9 x 10 ⁴ Pa
EH1200/1200C	0 to 90 mbar	0 to 0.9 x 10 ⁴ Pa	0 to 75 mbar	0 to 0.75 x 10 ⁴ Pa
EH2600/2600C	0 to 80 mbar	0 to 0.8 x 10 ⁴ Pa	0 to 67 mbar	0 to 0.67 x 10 ⁴ Pa
EH4200/4200C	0 to 60 mbar	0 to 0.6 x 10 ⁴ Pa	0 to 50 mbar	0 to 0.5 x 10 ⁴ Pa

2.3 Recommended backing pumps

Because of the flexibility of the hydrokinetic drive, there is a wide range of backing pumps which are suitable for use with the EH Mechanical Booster pumps. Contact your supplier or BOC Edwards for advice on suitable backing pumps.

2.4 Connections

2.4.1 Vacuum connections

	Inlet	Outlet
EH250	ISO63	ISO40
EH500A	ISO100	ISO63
EH1200/1200C	ISO160	ISO100
EH2600/2600C	ISO160	ISO100
EH4200/4200C	ISO250	ISO100

2.4.2 Cooling-water connections

Inlet connection	³ / ₈ inch BSP male
Outlet connection	³ / ₈ inch BSP male

2.4.3 Coupling-cover purge connection (EH1200C/2600C/4200C only)

Purge connection	¹ / ₄ inch compression fitting
------------------	--

2.5 Electrical data

Note: The motors of EH250 and EH500A pumps are supplied configured for 'low voltage' operation (240 V and lower), the motors of EH1200/1200C, EH2600/2600C and EH4200/4200C pumps are supplied configured for 'high voltage' operation (380 V and higher): refer to Section 3.6.

Number of phases	3
Supply voltage	220-240 V/380-415 V at 50 Hz 208-230 V/460 V at 60 Hz
Voltage tolerance	±6%
Full load current ratings	See Table 2

		220 V 50 Hz	240 V 50 Hz	380 V 50 Hz	415 V 50 Hz	208 V 60 Hz	230 V 60 Hz	460 V 60 Hz
EH250 & EH500A	Full load (A)	6.3	5.8	3.7	3.4	6.1	5.5	2.8
	Rating (kW)	1.5	1.5	1.5	1.5	1.5	1.5	1.5
EH1200	Full load (A)	11.1	10.2	6.4	5.9	11.9	10.7	5.4
	Rating (kW)	3	3	3	3	3	3	3
EH2600 & EH4200 (7.5 kW)	Full load (A)	19.8	18.2	11.5	10.5	20.9	18.9	9.5
	Rating (kW)	7.5	7.5	7.5	7.5	7.5	7.5	7.5
EH2600 & EH4200 (11 kW)	Full load (A)	-	-	21.5	20.7	-	34.8	17.4
	Rating (kW)	-	-	11	11	-	11	11
EH1200C	Full load (A)	-	-	6	5.7	-	10	5
	Rating (kW)	-	-	3	3	-	3	3
EH2600C & EH4200C	Full load (A)	-	-	22	20	-	36	18
	Rating (kW)	-	-	11	11	-	11	11

Table 2 - Full load current ratings

2.6 Coupling-cover nitrogen purge supply (EH1200C/2600C/4200C only)

Nitrogen supply pressure	1 to 9 bar gauge (2 to 10 bar absolute, 2×10^5 to 1×10^6 Pa)
Regulated pressure	0.3 to 0.5 bar absolute (3×10^4 to 5×10^4 Pa)

2.7 Noise and vibration data

Continuous A-weighted sound pressure level measured
at 1 metre from a major surface of the pump

EH250	72 dB (A)
EH500A	72 dB (A)
EH1200/EH1200C	76 to 77 dB (A)
EH2600/EH2600C	85 dB (A) (80 dB (A) with muffled fan)
EH4200/EH4200C	85 dB (A) (80 dB (A) with muffled fan)

Vibration	
BS 4675	Class 1B grade

2.8 Item Numbers

The Item Numbers for the different versions of the EH pumps are shown in Table 3.

	220-240 V/380-415 V 3-phase, 50 Hz		208-230 V/460 V 3-phase, 60 Hz	
	Hydrocarbon	PFPE	Hydrocarbon	PFPE
EH250	A301-51-935	A301-53-935	A301-52-936	A301-54-936
EH500A	A302-71-935	A302-73-935	A302-72-936	A302-74-936
EH1200	A305-90-935	A305-92-935	A305-91-936	A305-93-936
EH1200C	A305-55-900	-	A305-56-982	-
EH2600, 7.5 kW	A307-51-935	A307-53-935	A307-52-936	A307-54-936
EH2600, 11 kW	A307-51-946	-	A307-52-982	-
EH2600C	A307-55-900	-	A307-56-982	-
EH4200, 7.5 kW	A309-51-935	A309-53-935	A309-52-936	A309-54-936
EH4200, 11 kW	A309-51-946	-	A309-52-982	-
EH4200C	A309-55-900	-	A309-56-982	-

Table 3 - Item Numbers

3 INSTALLATION

3.1 Safety

WARNING

Obey the safety instructions given below and take note of appropriate precautions. If you do not, you can cause injury to people and damage to equipment.

- A suitably trained and supervised technician must install your EH pump.
- Ensure that the installation technician is familiar with the safety procedures which relate to the products pumped. Wear the appropriate safety-clothing when you come into contact with contaminated components. Dismantle and clean contaminated components inside a fume-cupboard.
- Consult BOC Edwards publication P300-20-000 (Vacuum pump and vacuum system safety) before you install and use the EH pump to process hazardous materials.
- Vent and purge the pumping system before you start installation work.
- Check that all the required components are available and of the correct type before you start work.
- Provide adequate access to all pump servicing points and oil-level sight-glasses.
- Disconnect the other components in the pumping system from the electrical supply so that they cannot be operated accidentally.
- Do not reuse 'O' rings and Co-Seals.
- Leak-test the system after installation work is complete and seal any leaks found to prevent leakage of hazardous substances out of the system and leakage of air into the system.

3.2 System requirements

Consider the following points when you design your pumping system:

- You must use a suitable backing pump: refer to Section 2.
- The EH pump must be mounted on a firm, level surface.
- Vacuum pipelines must be adequately supported to stop the transmission of stress to pipeline joints.
- If necessary, incorporate flexible pipelines in your system pipelines to reduce the transmission of vibration and to prevent loading of the coupling joints. If you use flexible pipelines, you must ensure that you use flexible pipelines which have a maximum pressure rating which is greater than the highest pressure that can be generated in your system.
- You must be able to isolate the pump-inlet and exhaust from the atmosphere and from your vacuum system if you will use or produce corrosive chemicals in the pump.

- Limit the maximum continuous gas heat-input to less than 200 W.
- Ensure that your design incorporates all appropriate safety precautions if toxic, inflammable or explosive gases or particulates will be pumped.
- You must be able to purge with an inert gas when you shut down the pumping system to dilute dangerous gases to safe concentrations. Consult BOC Edwards or your supplier if you are in doubt.

If the EH pump is to be fitted in a new system, ensure that all preliminary pipelines have been installed and that a suitable base for the pump has been prepared before you start installation. Check that the following services and facilities are available for connection to the pump:

- Cooling-water supply and return
- Electrical supply
- Exhaust-extraction system.

Ensure that debris does not get into the pump when you install it. If the pump is to replace a pump in an existing system, purge the existing pump with nitrogen for 15 minutes before you disconnect it.

3.3 Unpack and inspect

Use the following procedure to unpack and inspect the pump:

1. Place the pallet in a convenient position with a fork lift truck or a pallet truck.
2. Remove all packing materials.
3. Use suitable lifting-gear attached to the lifting-eyes provided on the pump to remove the pump from its pallet. Do not try to lift the pump by hand (see Section 2 for the mass of your pump).
4. Remove all protective covers and inspect the pump. If the pump is damaged, notify your supplier and the carrier in writing within three days; state the Item Number of the pump together with your order number and your supplier's invoice number. Retain all packing materials for inspection. Do not use the pump if it is damaged.
5. If the pump is not to be used immediately, refit the protective covers. Store the pump in suitable conditions as described in Section 6.1.

3.4 Fill the pump with oil

WARNING

Changing the oil in a pump from hydrocarbon to PFPE (Fomblin) could potentially cause a safety hazard. Fomblin pumps are generally used in hazardous applications which may involve the pumping of gases with high concentrations of oxygen. If hydrocarbon oil comes into contact with gases with an oxygen concentration greater than 25%, an explosion can occur.

Therefore, if you want to convert a pump that has been used with hydrocarbon oil to use PFPE (Fomblin) oil, you cannot simply flush the pump with new PFPE oil. You must return the pump to a BOC Edwards Service Centre for overhaul and cleaning by qualified BOC service engineers. The change in oil type requires a complete strip down of the pump, and thorough cleaning of all parts, so that all traces of hydrocarbon oil are removed.

CAUTION

Ensure that the oil-levels in the pump are correct. If an oil-level is incorrect, pump performance may be affected and the pump may be damaged.

3.4.1 Coupling-cover

We recommend that the coupling-cover oil-level is maintained at the recommended oil-level shown in Figure 12, item 5; if the oil-level is above or below the recommended oil-level, the performance of the pump may be affected. Do not allow the coupling-cover oil-level to fall below the bottom of the reflector plate (Figure 12, item 4) or the pump may be damaged.

1. Remove the coupling-cover oil filler-plug (Figure 1, item 3).
2. Refer to Figure 12. Fill the coupling-cover with the recommended type of oil until the oil-level reaches the recommended oil-level (5) at the top of the reflector plate (4) in the oil-level sight-glass (3).
3. Refit the coupling-cover oil filler-plug.

3.4.2 Shaft-seal reservoir

WARNING

Ensure that the correct vented filler-plug is refitted in the shaft-seal reservoir. If you use a non-vented plug, the reservoir will be pressurised and the oil sight-glass may fracture.

Note: Some early model pumps are fitted with an all-metal vented filler-plug (that is, there is no plastic insert in the filler-plug). On these pumps, the shaft-seal sight-glass should be full. If it is not, the oil-level is too low and you must fill the reservoir to the bottom thread of the vented filler-plug.

We recommend that you fill the shaft-seal reservoir so that the oil-level is at the recommended oil-level, shown in Figure 12, item 2. You can operate the pump as long as the oil-level is above the bottom of the reflector plate. Do not allow the shaft-seal oil-level to fall below the bottom of the reflector plate or the pump may be damaged. You must use the same oil you used to fill the coupling-cover.

1. Remove the shaft-seal reservoir vented oil filler-plug (Figure 1, item 2).
2. Refer to Figure 12. Fill the shaft-seal reservoir with oil until the oil-level is at the recommended oil-level (2) at the top of the reflector plate (6).
3. Refit the vented oil filler-plug.

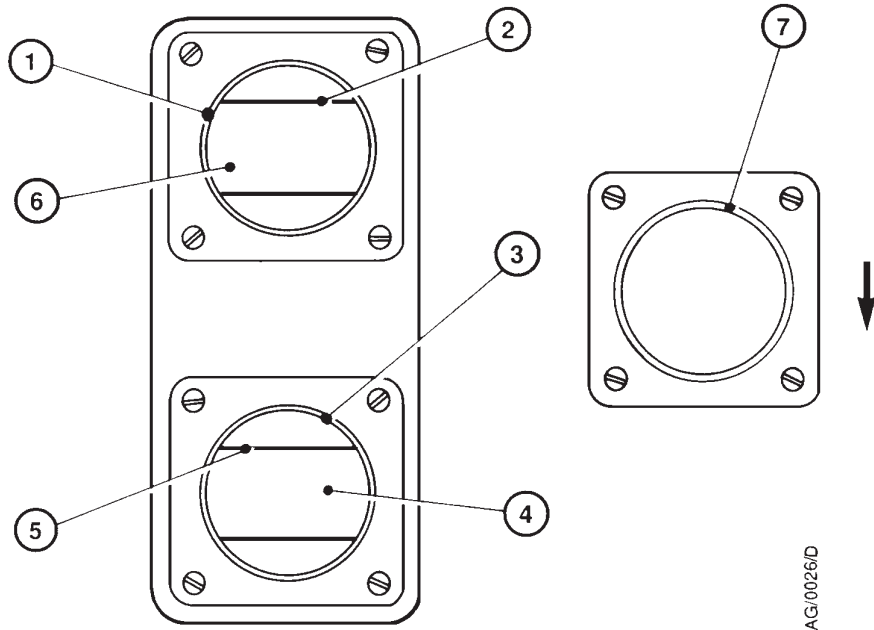

- | | |
|--|--|
| <ol style="list-style-type: none"> 1. Shaft-seal reservoir sight-glass 2. Shaft-seal reservoir recommended oil-level 3. Coupling-cover sight-glass 4. Coupling-cover reflector plate | <ol style="list-style-type: none"> 5. Coupling-cover recommended oil-level 6. Shaft-seal reflector plate 7. Direction of rotation sight-glass * (the arrow shows the correct direction of rotation) |
|--|--|

* Not fitted to EH2600, EH2600C, EH4200 and EH4200C pumps

Figure 12 - Sight-glasses

3.4.3 Gear-cover (EH1200/1200C, EH2600/2600C and EH4200/4200C pumps only)

Use the following procedure to fill the gear-cover on EH1200, EH1200C, EH2600, EH2600C, EH4200 and EH4200C pumps. You must fill the gear-cover with the same oil you used to fill the coupling-cover and shaft-seal reservoir.

1. Remove the oil filler-plug on the top of the gear-cover (Figure 2, item 6).
2. Fill the gear-cover with oil until the oil-level is at the middle of the reflector plate in the gear-cover oil-level sight-glass (Figure 2, item 8).
3. Refit the oil filler-plug.

3.5 Cooling-water connections (EH1200/1200C, EH2600/2600C and EH4200/4200C pumps only)

Note: You can operate the EH1200/1200C continuously without cooling-water if the inlet pressure is kept below 5 mbar (5×10^2 Pa) and the pumpdown time is no longer than 10 minutes.

Connect the cooling-water supply and return lines to the $\frac{3}{8}$ inch BSP connectors. One connector is on the rear of the coupling-cover, the other connector is on the underside of the gear-cover. You can connect the supply and return lines to either of the connectors; the direction of cooling-water flow is not important.

Refer to Section 2 for the minimum cooling-water flow rate required. Do not allow the cooling-water supply pressure to go above the maximum pressure stated in Section 2.

3.6 Electrical connections

WARNING

The pump must be connected to an electrical earth (ground).

3.6.1 Electrical supply configuration

The motors of the EH250 and EH500A pumps are supplied configured for 'low-voltage' operation (240 V and lower).

The motors of the EH1200, EH1200C, EH2600, EH2600C, EH4200 and EH4200C pumps are supplied configured for 'high-voltage' operation (380 V and higher).

Refer to Table 4 before you connect the electrical supply to the pump motor (as described in Section 3.6.2). Table 4 tells you which figure you must refer to for the electrical connections for your pump and your electrical supply.

Electrical supply voltage and frequency	Refer to Figure	
	EH250/500A	EH1200/2600/4200 EH1200C/2600C/4200C
208 V, 60 Hz	15	17
220 V, 50 Hz	13	13
230 V, 60 Hz	15	17
240 V, 50 Hz	13	13
380 - 415 V, 50 Hz	14	14
460 V, 60 Hz	16	16

Table 4 - Electrical supply connection configurations

3.6.2 Motor connections

WARNING

On EH1200C, EH2600C and EH4200C pumps, you must use a suitable flameproof cable-gland to connect the electrical supply cable to the pump-motor terminal-box. If you do not, the installation will not be flameproof.

CAUTION

The motor must be correctly configured and you must make the correct electrical connections for your electrical supply. If you do not, you can damage the motor.

Connect the motor to the electrical supply as described below. Connect the supply through a contactor which has overload-protection or use a controller which incorporates a contactor. You must use a contactor which has a manual reset control. If you do not, the pump could automatically restart after an electrical overload or an electrical supply failure.

1. Remove the motor terminal-box cover (Figures 1 and 2, item 1).
2. Check your electrical supply voltage and frequency. If necessary, configure the motor to operate with your supply voltage (see Section 3.6.1).
3. Remove the plug from the cable-entry hole that you will use for the electrical supply cable. Choose the most suitable hole for your application.
4. Fit a suitable cable-gland to the cable-entry hole. The cable-gland (and adaptor, if fitted) must provide a protective seal to IP44 (or higher), as defined by IEC 529.
5. Pass the electrical supply cable through the cable-gland.
6. Connect the wires of the cable to the appropriate terminals, as shown in Figures 13 to 17 (refer to Table 4).
7. Tighten the cable-gland and refit the terminal-box cover.

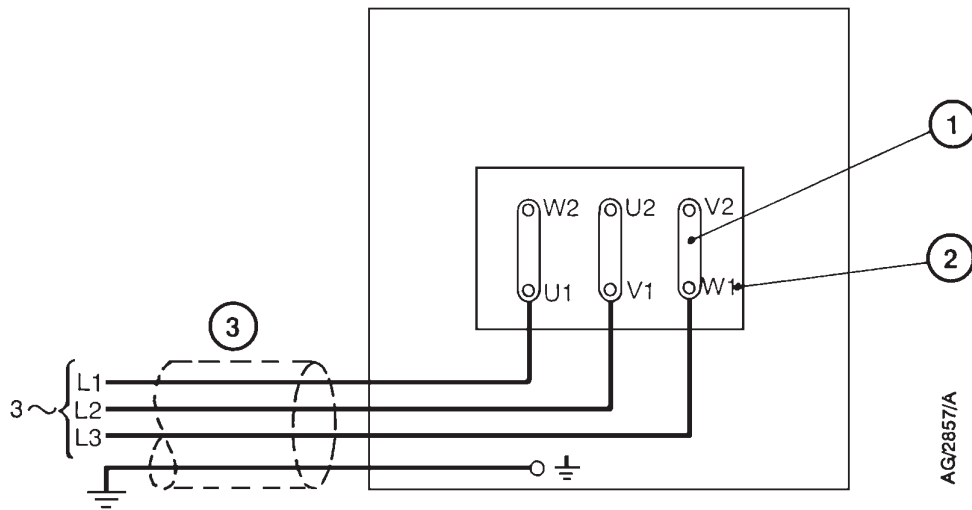

1. Links
2. Terminal markings
3. To electrical supply

Figure 13 - Electrical supply connection: EH250/500A/1200/2600/4200: 220 to 240 V, 50 Hz

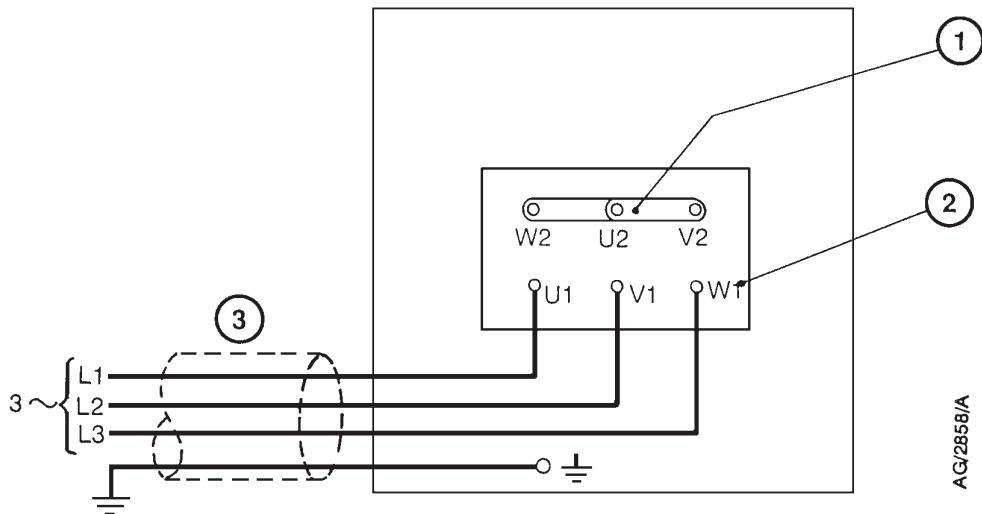

1. Links
2. Terminal markings
3. To electrical supply

Figure 14 - Electrical supply connection: EH250/500A/1200/2600/4200: 380 to 415 V, 50 Hz

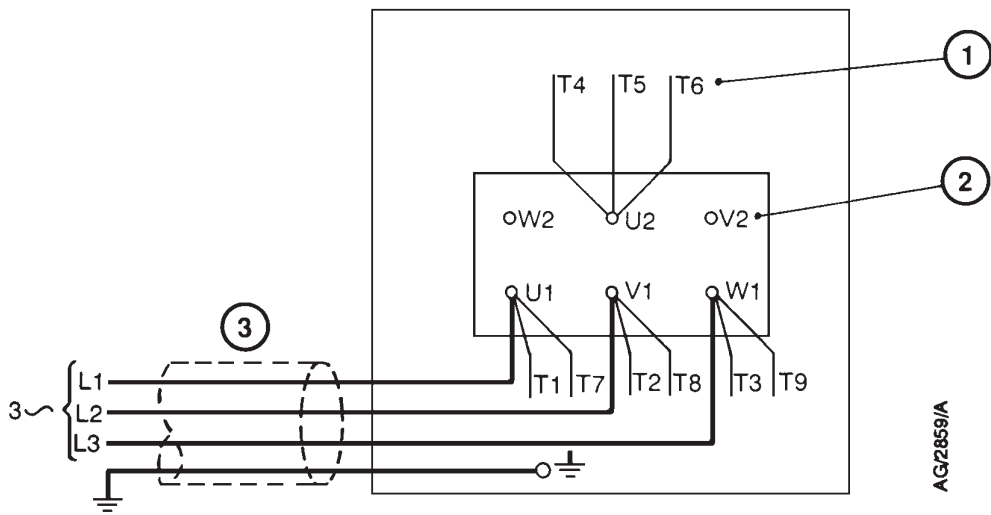

1. Motor wire markings
2. Terminal markings
3. To electrical supply

Figure 15 - Electrical supply connection: EH250/500A: 208 to 230 V, 60 Hz

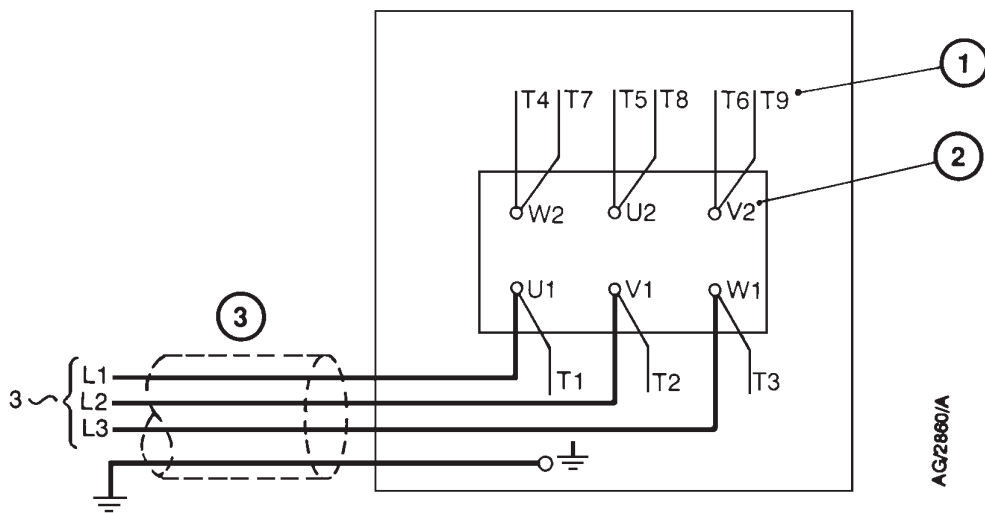

1. Motor wire markings
2. Terminal markings
3. To electrical supply

Figure 16 - Electrical supply connection: EH250/500A/1200/2600/4200: 460 V, 60 Hz

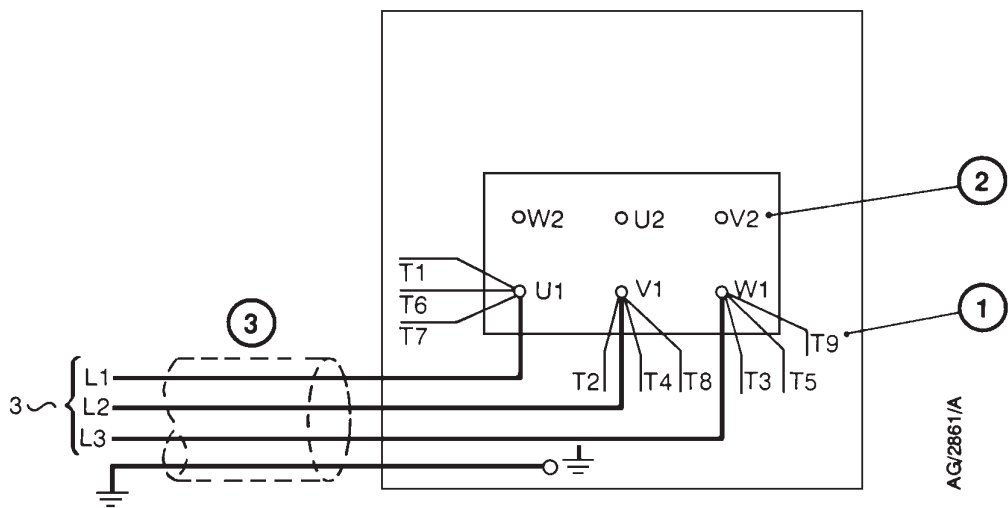

1. Motor wire markings
2. Terminal markings
3. To electrical supply

Figure 17 - Electrical supply connection: EH1200/2600/4200: 208 to 230 V, 60 Hz

3.7 Check the direction of pump rotation

WARNING

Blank the inlet or connect the pump to the vacuum system before you check the direction of pump rotation. If you do not, there is danger of objects being trapped in the rotating rotors.

It is possible for the three-phase electrical supply to the motor to be phased incorrectly. If the supply is phased incorrectly, the rotors will rotate slowly in the reverse direction or remain stationary. Check the direction of rotation as described below.

1. Check that the pump is connected to the vacuum system or that the inlet is blanked off.
2. Connect the backing pump and switch the backing pump on.
3. On EH2600, EH2600C, EH4200 and EH4200C pumps, the correct direction of rotation is indicated by an arrow on the motor fan cover (Figure 2, item 16). To determine the direction of rotation: watch the motor fan inside the fan cover, switch on the EH pump for two or three seconds, then switch the pump off.

On EH250, EH500A, EH1200 and EH1200C pumps, you can use the method above to determine the direction of rotation. Alternatively, the direction of rotation is also indicated by an arrow next to the direction of rotation sight-glass (Figure 1, item 10 and Figure 2, item 13): watch the motor-coupling in the sight-glass (Figure 12, item 7), switch on the EH pump for two or three seconds, then switch the pump off.

4. Check that the direction of rotation of the coupling noted in Step 3 was the same as that indicated by the rotation arrow on the motor or on the direction of rotation sight-glass. If the direction of rotation was correct, continue at Section 3.8.
5. If the direction of rotation of the coupling was incorrect, switch off the backing pump; isolate the EH pump from the electrical supply; reverse any two of the phase-wires in the motor terminal-box; repeat the check from Step 2 to ensure that the direction of rotation is now correct.

3.8 Connect the coupling-cover purge nitrogen supply (EH1200C, EH2600C and EH4200C only)

WARNING

Your nitrogen supply pressure must comply with the requirements of Section 2.6. If it does not, the purge pipelines may become over-pressurised and may explode.

Use a rigid metal (such as stainless steel) pipeline with an outside diameter of $1/4$ inch for your nitrogen supply.

We recommend that you install an automatically operated isolation-valve in your nitrogen supply pipeline, configured so that:

- The coupling-cover purge nitrogen supply is on whenever the pump is on.
- The coupling-cover purge nitrogen supply is off whenever the pump is off.

Refer to Figure 2 and use the following procedure to connect your coupling-cover purge nitrogen supply:

1. Remove the $1/4$ inch blanking plug from the coupling-cover oil filler-plug (4).
2. Fit a suitable $1/4$ inch compression fitting connector to the oil filler-plug.
3. Fit your nitrogen supply pipeline into the compression fitting and tighten to secure the connection.

3.9 Connect the pump-inlet and outlet

Pump-inlet and outlet connections are made with standard ISO flanges, BOC Edwards trapped 'O' rings and (on the EH250 pump only) a BOC Edwards Co-Seal.

The EH2600, EH2600C, EH4200 and EH4200C pumps have two alternative outlet positions :

- on the underside of the pump
- at the side of the pump.

As supplied, these pumps are configured to use the outlet at the side of the pump and the flange on the underside of the pump is blanked off. If you do not wish to use the side outlet, remove the blanking-plate and 'O' ring from the outlet on the underside of the pump and refit the blanking-plate with a new 'O' ring over the side outlet-flange.

Take note of the following when you connect your EH pump to the vacuum system.

- Move the pump to the required location and ensure that it is level and secure.
- For optimum pumping speeds, ensure that the pipeline connected to the pump-inlet is as short as possible and has a bore size not less than the inlet port diameter.
- Use a flexible connection in the pipeline from the vacuum system to the pump to reduce vibration and stress in the system pipelines (see Section 3.2).
- On very dusty applications, use a low-impedance inlet-filter to minimise abrasion in the pump.

3.10 External evacuation of coupling-cover (optional)

The coupling-cover may be evacuated using an external pump. A description of the connections required is beyond the scope of this manual. Contact your supplier or your nearest BOC Edwards company for advice if you wish to use this facility.

4 OPERATION

4.1 Operational safety

WARNING

Do not touch any part of the EH pump when it is switched on. Surfaces of the pump are very hot, especially at high inlet pressures, and can cause injury to people and damage to equipment.

If you operate the EH250 or EH500A pump in an area of poor ventilation, the temperature of the coupling-cover can reach 100 °C and above. Take all necessary precautions to avoid accidental contact with the coupling-cover; if necessary, use a pump enclosure or fit a guard to the pump.

If you operate the EH1200 or EH1200C pump with the inlet pressure higher than 4 mbar for a long period, the stator and the coupling-cover will reach very high temperatures. Take all necessary precautions to avoid accidental contact with the stator and the coupling-cover; if necessary, use a pump enclosure or fit a guard to the pump.

4.2 Start-up procedure

4.2.1 Pre-start checks

1. Check that the pump oil-levels are correct (see Section 3.4).
2. Check that the pump is correctly installed, especially after initial installation and maintenance.

4.2.2 Start-up

Start-up the EH pump as described in the procedure below. This procedure assumes that the pump and the vacuum system are at atmospheric pressure.

1. On EH1200, EH1200C, EH2600, EH2600C, EH4200 and EH4200C pumps only: switch on the cooling-water supply and check that there is an adequate flow of cooling-water at the correct pressure (see Section 2.1).
2. Close all valves to atmospheric pressure and ensure that all other openings are closed.
3. Switch on the backing pump and open the backing valve (if fitted).
4. Switch on the mechanical booster pump.
5. Slowly open the pump-inlet isolation-valve (if fitted).
6. Allow the pump to run for approximately fifteen minutes to achieve normal operating temperature.
7. Check the water connections for leaks.

4.3 Shut-down

1. Close the pump-inlet isolation-valve (if fitted).
2. Switch off the mechanical booster pump.
3. Open the backing pump air-admittance valve (if fitted) and switch off the backing pump.
4. On EH1200, EH1200C, EH2600, EH2600C, EH4200 and EH4200C pumps only: turn off the cooling-water supply.

5 MAINTENANCE

5.1 Safety

WARNING

Obey the safety instructions given below and take note of appropriate precautions. If you do not, you can cause injury to people and damage to equipment.

- A suitably trained and supervised technician must maintain the pump.
- Dismantle the pump in a clean workshop environment, with the correct tools and safety facilities available.
- Ensure that the maintenance technician is familiar with the safety procedures which relate to the products pumped. Wear the appropriate safety-clothing when you come into contact with contaminated components. Dismantle and clean contaminated components inside a fume-cupboard.
- Allow the pump to cool to a safe temperature before you start maintenance work.
- Vent and purge the pumping system with nitrogen before you start maintenance work.
- Check that all the required parts are available and of the correct type before starting work.
- Isolate the pump and other components from the electrical supply so that they cannot be operated accidentally.
- Re-check the pump rotation direction if the electrical supply has been disconnected.
- Do not reuse 'O' rings and Co-Seals.
- Dispose of components and waste oil safely (see Section 6.2).
- Take care to protect sealing-faces from damage.
- Do not touch or inhale the thermal breakdown products of fluorinated materials which may be present if the pump has been overheated to 260 °C and above. These breakdown products are very dangerous. Fluorinated materials in the pump may include oils, greases and seals. The pump may have overheated if it was misused, if it malfunctioned or if it was in a fire. BOC Edwards Material Safety Data Sheets for fluorinated materials used in the pump are available on request: contact your supplier or BOC Edwards.
- Leak-test your system after installation and maintenance to prevent leakage of dangerous substances out of the system and leakage of air into the system.

The pump will be contaminated with the process chemicals that have been pumped. Ensure that you take adequate precautions to protect people from the effects of dangerous substances if contamination has occurred.

5.2 Maintenance plan

Table 5 details the maintenance operations necessary to maintain EH pumps in normal use. Instructions for each operation are given in the section shown.

More frequent maintenance may be required if the pump is used to pump corrosive or abrasive gases and vapours. If necessary, adjust the maintenance plan according to your experience.

Operation	Frequency	Refer to Section
Check the oil-levels	3 monthly	5.3
Inspect the pump connections	Monthly	5.4
Change the pump oil	As required	5.5
Lubricate the rear bearing (EH250/500A pumps only)	12 monthly	5.6

Table 5 - Maintenance plan

5.3 Check the oil-levels

CAUTION

Ensure that the oil-levels in the pump are correct. If an oil-level is incorrect, pump performance may be affected and the pump may be damaged.

Note: If there is a loss of oil from the shaft-seal reservoir, the shaft-seal may have failed. You cannot replace the shaft-seal. Contact your supplier or a BOC Edwards Service Centre for advice. If you have an early model pump, refer to the note in Section 3.4.2.

Use the following procedure to check the oil-levels in the sight-glasses. Refer to Figures 1 and 2 for the location of the filler-plugs and sight-glasses. During normal operation, the coupling-cover sight-glass (Figure 12, item 3) may appear empty or show a froth because the oil is in circulation around the coupling.

1. Refer to Figure 12. Check the shaft-seal oil-level. If the oil-level is below the bottom of the reflector plate (6), refer to Section 3.4 and refill the shaft-seal reservoir.
2. Check the coupling-cover oil-level. If the oil-level is below the top of the reflector plate, refer to Section 3.4 and refill the coupling-cover oil reservoir.
3. On EH1200, EH1200C, EH2600, EH2600C, EH4200 and EH4200C pumps only, check the gear-cover oil-level. If the oil-level is below the middle of the reflector plate, refer to Section 3.4 and refill the gear-cover.

5.4 Inspect the pump connections

1. Check that the cooling-water connections are secure.
2. Inspect the cooling-water pipelines and connections for corrosion, leaks and damage.
3. Check that the electrical connections are secure.
4. Check the electrical supply cables for damage.
5. Inspect all the vacuum pipelines for corrosion and damage. Check that all the vacuum connections are secure.
6. On EH1200C, EH2600C and EH4200C pumps only, inspect the coupling-cover purge nitrogen supply pipeline for corrosion and damage. Check that the pipeline connection to the coupling-cover is secure.

5.5 Change the pump oil

WARNING

Changing the oil in a pump from hydrocarbon to PFPE (Fomblin) could potentially cause a safety hazard. Fomblin pumps are generally used in hazardous applications which may involve the pumping of gases with high concentrations of oxygen. If hydrocarbon oil comes into contact with gases with an oxygen concentration greater than 25%, an explosion can occur.

Therefore, if you want to convert a pump that has been used with hydrocarbon oil to use PFPE (Fomblin) oil, you cannot simply flush the pump with new PFPE oil. You must return the pump to a BOC Edwards Service Centre for overhaul and cleaning by qualified BOC service engineers. The change in oil type requires a complete strip down of the pump, and thorough cleaning of all parts, so that all traces of hydrocarbon oil are removed.

CAUTION

Ensure that the oil-levels in the pump are correct. If an oil-level is incorrect, pump performance may be affected and the pump may be damaged.

Replace the pump oil as described below. Refer to Figures 1 and 2 for the location of the oil-filler and drain-plugs.

1. Switch off the pump and allow it to cool.
2. Remove the coupling-cover oil filler-plug.
3. Remove the coupling-cover oil drain-plug from the underside of the coupling-cover and allow the oil to drain into a suitable container.
4. Remove the shaft-seal vented oil filler-plug. Use a suitable pump to suck the oil out of the shaft-seal reservoir.

5. Refit the coupling-cover oil drain-plug.
6. Refer to Section 3.4 and fill the coupling-cover and shaft-seal reservoir with oil.
7. Refit the coupling-cover oil filler-plug and the shaft-seal reservoir oil filler-plug.
8. On EH1200, EH1200C, EH2600, EH2600C, EH4200 and EH4200C pumps only:
 - Remove the oil filler-plug on the gear-cover.
 - Remove the oil drain-plug from the underside of the gear-cover and allow the oil to drain into a suitable container.
 - Refit the oil drain-plug and refer to Section 3.4 to refill the gear-cover with oil.
 - Refit the oil filler-plug.

5.6 Lubricate the rear-bearing (EH250 and EH500A pumps only)

Use the procedure below to replace the grease in the rear-bearing.

1. Switch off the pump and isolate it from the electrical supply. Vent the pump to atmospheric pressure.
2. Refer to Figure 18. Remove the four plastic cover-caps (8) from the bearing end-cover (6).
3. Undo and remove the socket-head screws (7) located under the four plastic cover-caps.
4. Remove the end-cover (6) and 'O' ring (5). Dispose of the 'O' ring safely.
5. Note the exact location of the shims (4) and spacers (3) inside the end-cover (6). Clean off all visible grease from the end-cover taking care not to misplace or damage the shims and spacers.
6. Use a soft, clean, lint free cloth or a plastic or wooden spatula to remove all visible grease from both bearings (2).
7. Fill the visible side of each bearing (2) with clean grease, then lightly force the grease into the bearing.
8. Refill the visible side of each bearing (2) with clean grease.
9. Apply a light wipe of high-vacuum grease to the new 'O' ring (5) and fit into the groove in the end cover (6).
10. Check that the shims (4) and spacers (3) are correctly located in the end-cover (6).
11. Refit the end-cover (6) and secure it with the four socket-head screws (7). Tighten the screws evenly and refit the plastic cover-caps (8).
12. Leak test the system and seal any leaks found.

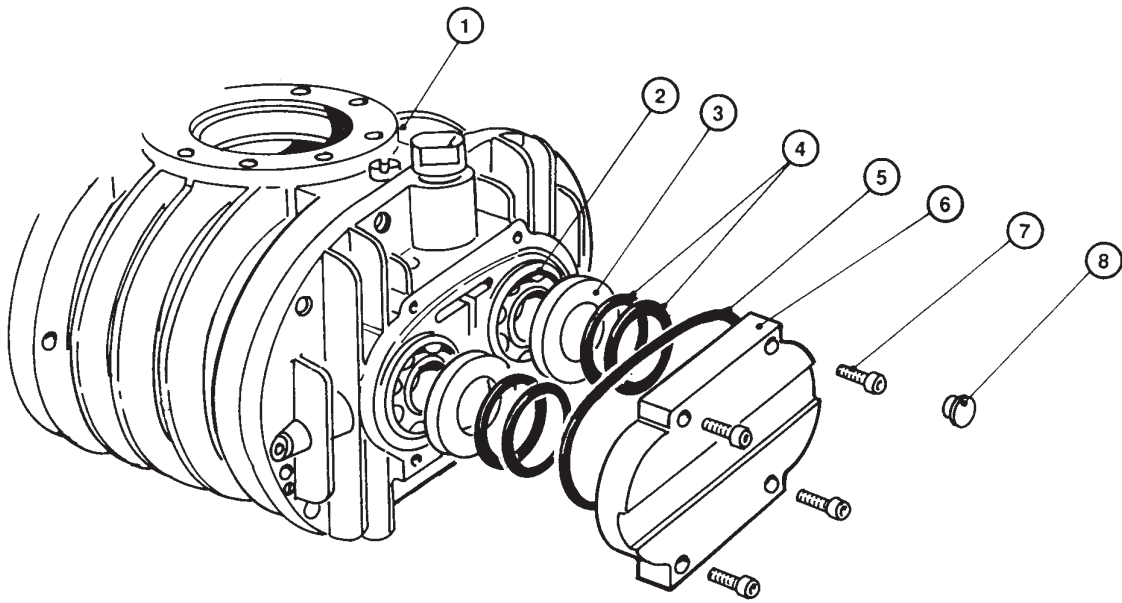

AG2689/A

- | | |
|--------------|----------------------|
| 1. Pump-body | 5. 'O' ring |
| 2. Bearing | 6. End-cover |
| 3. Spacer | 7. Socket-head screw |
| 4. Shims | 8. Cover-cap |

Figure 18 - Lubricate the rear bearing (EH250/500A pumps only)

6 STORAGE AND DISPOSAL

6.1 Storage

CAUTION

Observe the storage temperature limits stated in Section 2. Storage below -30 °C will permanently damage the pump seals and lubricants.

Use the procedure below to store the pump.

1. Shut-down the pump as described in Section 4.
2. Isolate the pump from the electrical supply and disconnect it from the vacuum system.
3. Clean the pump and change the oil as described in Section 5.
4. Place protective covers over the inlet and outlet-flanges.
5. Store the pump in cool, dry conditions until required for use. When required, prepare and install the pump as described in Section 3.

6.2 Disposal

Dispose of the pump and any components safely in accordance with all local and national safety and environmental requirements.

Take particular care with components and waste oil which have been contaminated with dangerous process substances.

7 SERVICE AND SPARES

7.1 Introduction

BOC Edwards products and spares are available from BOC Edwards companies in Belgium, Brazil, Canada, China, France, Germany, Israel, Italy, Japan, Korea, Singapore, Switzerland, United Kingdom, U.S.A, and a world-wide network of distributors. The majority of these centres employ Service Engineers who have undergone comprehensive BOC Edwards training courses.

Order spare parts from your nearest BOC Edwards company or distributor. When you order, please state for each part required:

- Model and Item Number of your equipment
- Serial number (if any)
- Item Number and description of part.

7.2 Service

BOC Edwards products are supported by a world-wide network of BOC Edwards Service Centres. Each Service Centre offers a wide range of options including: equipment decontamination; service exchange; repair; rebuild and testing to factory specifications. Equipment which has been serviced, repaired or rebuilt is returned with a full warranty.

Your local Service Centre can also provide BOC Edwards engineers to support on-site maintenance, service or repair of your equipment.

For more information about service options, contact your nearest Service Centre or other BOC Edwards company.

7.3 Spares

The spare parts listed below are available for the EH pump:

Product	Item Number
RT15 Fomblin grease (100 gm)	H113-50-003
End-cover 'O' ring	H021-22-091
Ultragrade 20 oil (1 l)	H110-24-015
Ultragrade 20 oil (4 l)	H110-24-013
Krytox 1514 fluid (1 kg)	H113-08-018
Krytox 1514 fluid (5 kg)	H113-08-020