

# TURBOVAC SL 80

Wide-Range Turbomolecular Pump with  
Integrated or External Frequency Converter

Incorporation Declaration & Operating Instructions  
130000760\_002\_A1

Part Nos.

800002V3001

to

800002V3004



# Contents

	Page
<b>0 Important Safety Information</b>	<b>5</b>
0.1 Mechanical hazards	5
0.2 Electrical hazards	6
0.3 Thermal hazards	7
0.4 Hazards caused by materials and substances	7
0.5 Danger of ignition	8
0.6 Dangers in connection with safety-related measures and precautions	8
0.7 Risk of damaging the pump	8
<b>1 Description</b>	<b>9</b>
1.1 Design	10
1.2 Standard equipment	10
1.3 Technical data	11
1.4 Ordering data	16
1.5 Accessories	16
<b>2 Transport and storing</b>	<b>21</b>
<b>3 Installation</b>	<b>22</b>
3.1 Conforming utilization	22
3.1.1 Non-conforming utilization	22
3.2 Operating environment	24
3.3 Fitting accessories	25
3.4 Attach the pump to the vacuum chamber	28
3.5 Forevacuum connection	34
3.6 Connect the cooling	35
3.7 Connect purge gas or a venting valve	39
3.8 Electrical connection	40
3.8.1 Connecting pump and frequency converter	40
3.8.2 Connecting the power supply	42
3.8.3 Mounting the frequency converter	43
3.8.4 Relay status	46

# Contents

<b>4</b>	<b>Operation</b>	<b>47</b>
4.1	Media compatibility / purge gas	47
4.2	Start-up	47
4.3	Interfaces	48
4.3.1	RS 232 C interface (SERVICE X5)	49
4.3.2	RS 485 interface	50
4.3.3	Profibus DP	51
4.3.4	Ethernet/IP interface	51
4.3.5	Parameter list	52
4.3.6	Warning codes for parameter 227	56
4.4	Switching on	57
4.5	Shutting down	58
4.6	Venting	59
4.7	Bakeout	60
4.8	Removing the pump from the system	61
<b>5</b>	<b>Maintenance</b>	<b>62</b>
5.1	Cleaning	62
5.2	Oerlikon Leybold Vacuum Service	63
<b>6</b>	<b>Troubleshooting</b>	<b>64</b>
<b>7</b>	<b>Waste disposal</b>	<b>68</b>
	<b>EC Incorporation Declaration</b>	<b>70</b>
	<b>EC Declaration of Conformity</b>	<b>71</b>
	<b>Index</b>	<b>73</b>

Original installation and operating instructions.

# Safety Information

---

## NOTICE



### Obligation to Provide Information

Before installing and commissioning the TURBOVAC, carefully read these Operating Instructions and follow the information so as to ensure optimum and safe working right from the start.

---

The Oerlikon Leybold Vacuum **TURBOVAC SL 80** has been designed for safe and efficient operation when used properly and in accordance with these Operating Instructions. It is the responsibility of the user to carefully read and strictly observe all safety precautions described in this section and throughout the Operating Instructions. The pump **must only be operated in the proper condition and under the conditions described in the Operating Instructions**. It must be operated and maintained by trained personnel only. Consult local, state, and national agencies regarding specific requirements and regulations. Address any further safety, operation and/or maintenance questions to our nearest office.

---

## DANGER



DANGER indicates an imminently hazardous situation which, if not avoided, will result in death or serious injury.

## WARNING



WARNING indicates a potentially hazardous situation which, if not avoided, could result in death or serious injury.

## CAUTION



CAUTION indicates a potentially hazardous situation which, if not avoided, could result in minor or moderate injury.

## NOTICE



NOTICE is used to notify users of installation, operation, programming or maintenance information that is important, but not hazard related.

---

We reserve the right to alter the design or any data given in these Operating Instructions. The illustrations are not binding.

Retain the Operating Instructions for further use.

## 0 Important Safety Information

### 0.1 Mechanical hazards

- 1 Avoid exposing any part of the human body to the vacuum.
- 2 The pressure in the pump must not exceed 1.4 bar (absolute).
- 3 The pump is intended for generating a vacuum only. If there is a risk of an overpressure within the system and the pump, then the pump must be protected against this, by way of an overpressure safety valve, for example.
- 4 Vent the pump only up to atmospheric pressure.
- 5 When using the pump with a purge gas valve, protect the purge gas supply such that in the event of a malfunction no overpressure can occur within the system.
- 6 The pump must be firmly mounted to the vacuum chamber. If the mounting is not sturdy enough, pump blockage could cause the pump to break loose; internal pump components could be thrown in all directions. Never operate the pump (in bench testing, for example) without proper flanging to the vacuum chamber. Observe the information in Section 3.4.
- 7 We recommend to change the rotor after 80,000 hours of operation at the latest. Due to high-speed and temperature, the service life of the rotor is limited. If the rotor is changed too late, it may be destroyed. Thus in the flange mounts high forces and torque conditions can occur. The mounting screws for the pump may be torn off. When using clamped flange connections at the housing or with components above the housing, sudden twisting of the entire pump can be experienced.
- 8 Turbopumps as described in the following operation manual contain a high portion of kinetic energy due to their high rotational speed in combination with the specific rotor mass. In case of a malfunction of the system, for example rotor/stator contact or even a rotor crash, the rotational energy is released.
- 9 To avoid the destruction of the equipment and to prevent injuries of the operating staff the leading European manufacturers of vacuum pumps strictly recommend to follow the installation instructions as given in this manual.

---

#### WARNING



# Safety Information

---

**WARNING**

## 0.2 Electrical hazards

- 1 The electrical connections must only be provided by a trained electrician as specified, for example, by the regulations EN 50110-1. Observe local regulations.
  - 2 The frequency converter must only be connected to power supplies which meet the requirements for functional extra-low voltages with positive isolation in accordance with IEC 60364-4-41 (or local regulations) (PELV).
  - 3 Lethal voltages are present at the mains connections. Before starting with any maintenance and service work, de-energise (lockout/tagout) the product first.
  - 4 Unplug any connectors only when the mains voltage is switched off **and** the pump does no longer turn.
  - 5 Unauthorized device conversion and modifications are prohibited for safety reasons.
  - 6 Hazardous voltages are present within the frequency converter. When coming into contact with these, death or severe injury can result. After the pump has arrived at standstill, disconnect the frequency converter from the mains power and prevent it against being switched on inadvertently (lockout/tagout) before opening it. Basically there is no reason why the frequency converter should be opened. There are no user serviceable parts inside.
  - 7 When the connector cable is attached, the outputs at the frequency converter are not free of voltage.
  - 8 Lay connecting lines so that they cannot be damaged. Protect the lines against humidity and contact with water. Avoid any heat stress on the line due to unfavourable laying conditions.
  - 9 Suitably support the connecting lines so that the pumps are not exposed to any major mechanical stress.
  - 10 Do not expose pump, frequency converter and the connections to dripping water. Note the information on the IP type of protection.
  - 11 When storing pump, frequency converter and connecting lines in a humid atmosphere, these can suffer corrosion. Corrosion gives rise to conductive deposits which in turn can cause short-circuits and reduce the insulation levels of electrical components
  - 12 Transport pump, frequency converter and connecting cables only in their original packaging so as to avoid any mechanical damage which in turn may reduce air gaps and creepage distances.
  - 13 When applying external voltages above 42 V to the connection terminals, observe the applicable VDE safety regulations!
  - 14 Make the electrical connections only after pump and accessories (e.g. air cooler) have been installed mechanically.
-

## 0.3 Thermal hazards

- 1 Handle the equipment only while vented and cooled down.
- 2 During operation of the pump certain areas can get so hot (80 °C max.) so that there is the risk of suffering burns. Protect hot parts against being touched.
- 3 Note the warning information on the housing surface. If these warning notices have been removed, covered or obstructed, include corresponding additional warning notices.

---

### CAUTION



## 0.4 Hazards caused by materials and substances

- 1 The pump is not suited for pumping of reactive or corrosive media. If the rotor is attacked by process gases, it can suffer destruction. Thus in the flange mounts high forces and torque conditions can occur. The mounting screws for the pump may be torn off. When using clamped flange connections at the housing or with components above the housing, sudden twisting of the entire pump can be experienced.
- 2 When pumping dusty media, use a dust filter.
- 3 If low concentration corrosive or reactive gases are being pumped, then operate the pump with purge gas.
- 4 Please consult us as to which types of pump are required for specific processes and applications.
- 5 The forevacuum line must be tight. Hazardous gases can escape at leaks or the gases being pumped can react with air or humidity. A leak search will always be required after having installed the pump and after service work on the vacuum. Upon delivery the pump has an integral leak rate of  $< 5 \cdot 10^{-7}$  mbar-l/s. When pumping toxic gases we recommend a leak search on a regular basis.
- 6 If the pump has previously handled hazardous gases, implement the proper precautionary measures before opening the intake or exhaust connection. Before opening the pump, purge it for a longer period of time with an inert gas. If necessary, use gloves, a respirator and/or protective clothing and work under an exhaust hood. Firmly seal off the pump. When shipping the contaminated pump for servicing, please also state the type of hazard. For this you must use a form which we have prepared for you.
- 7 Contaminated parts can be detrimental to health and environment. Before beginning with any work, first find out whether any parts are contaminated. Adhere to the relevant regulations and take the necessary precautions when handling contaminated parts.

---

### DANGER



# Safety Information

---

**CAUTION****0.5 Danger of ignition**

- 1 During operation the pressure inside the turbomolecular pump is so low that there is no danger of ignition (at pressures below about 100 mbar). A hazardous condition will be created if flammable mixtures enter the hot pump at pressures above 100 mbar. During operation the pump can reach temperatures as high as 120°C internally, and at parts of the outside surfaces 80 °C. Sparks could occur in case of damage to the pump and these could ignite explosive mixtures. Also note the safety information provided by the gas supplier.

---

**CAUTION****0.6 Dangers in connection with safety-related measures and precautions**

- 1 The frequency converter is not equipped with its own emergency shut down switch. Such a facility needs to be provided from the side of the system.

---

**NOTICE****0.7 Risk of damaging the pump**

- 1 Never touch the rotor. Touching the rotor may cause injury and damage the rotor bearing.
  - 2 Foreign objects which enter the pump through the intake would cause serious damage to the rotor. That's why we recommend installing an inlet screen. Damages caused during operation without the inlet screen are excluded from warranty.
  - 3 The contact surfaces of pump housing, vacuum system and centering ring must be free of grease and dry so as to ensure sufficient stability in case the rotor seizes.
  - 4 Contact Oerlikon Leybold Vacuum first before planning to operate the pump without air cooling.
  - 5 Also water cooled pumps need cooling air for the frequency converter.
  - 6 Ensure correct polarity when connecting the TURBO.DRIVE. A wrong polarity may cause an internal fuse to blow. The fuse can only be changed by Oerlikon Leybold Vacuum Service.
  - 7 The interface connectors have UNC 4-40 threads. Do not use connectors with M3 treads.
  - 8 Disconnect and connect the cable connections only while the pump is turning no longer (green status LED off) **and** with the mains power switched off (yellow power LED off). Otherwise there is the risk of damaging the frequency converter.
  - 9 Exposure of the pump to accelerating forces must be avoided or reduced to such an extent that the rotor unit will not be excited by vibrations. In the case of critical applications you must consult our Applications Dept. first.
-



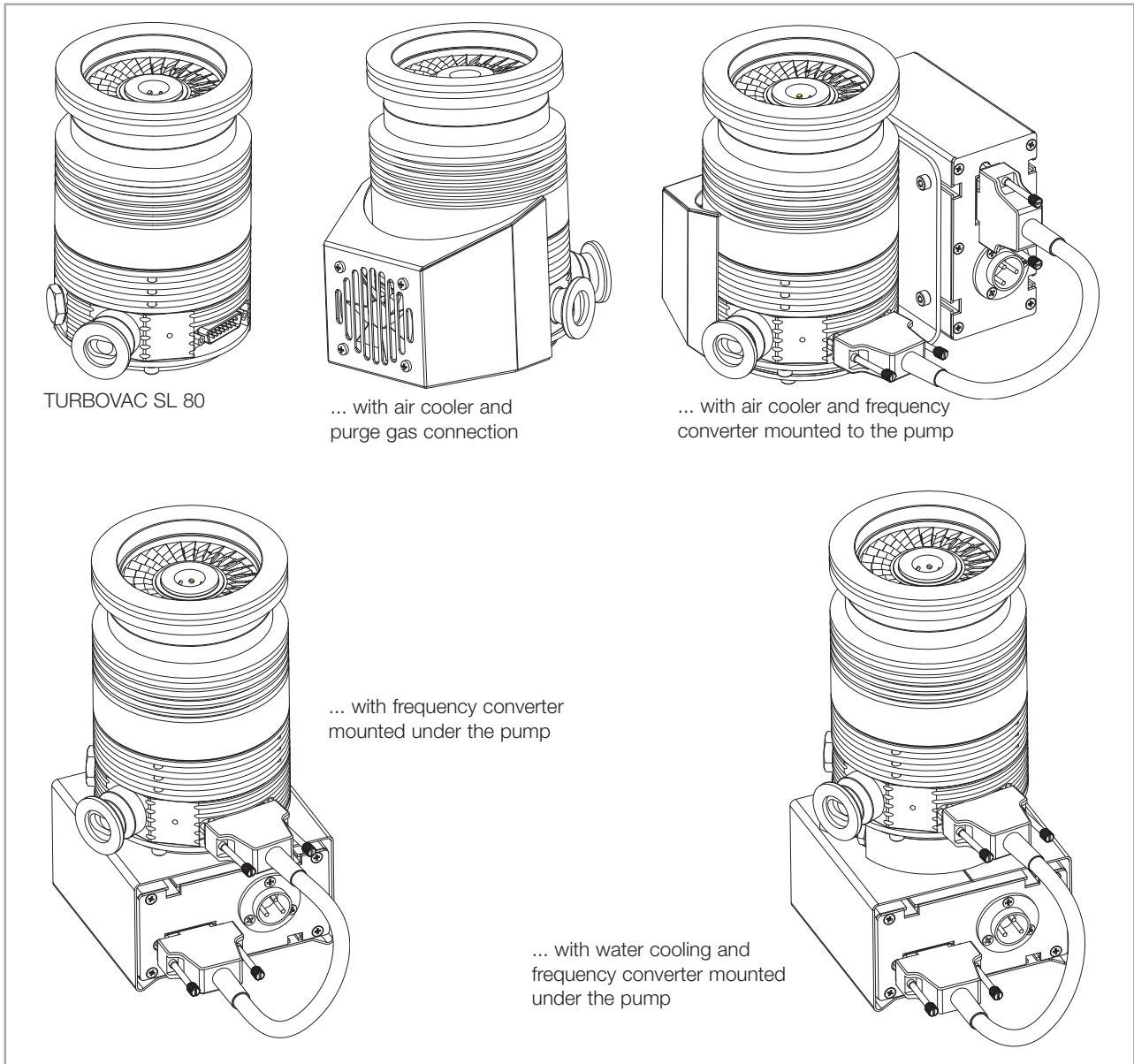

Fig. 1.1 Examples of SL 80

## 1 Description

The TURBOVAC SL 80 is a wide range turbomolecular pump designed to evacuate vacuum chambers down to pressure levels in the high vacuum range. It is suitable for pumping air and clean gases. The TURBO.DRIVE 400 frequency converter and a forevacuum pump are required for its operation.

## Use

# Description

## 1.1 Design

The pumps comprise essentially the pump housing, a multi-stage rotor with the stator group, and the drive.

The first section of the rotor is a turbomolecular pump rotor while the second tile represents a Holweck stage. The Holweck pumping stage increases the permissible forevacuum pressure level markedly when compared with the classic turbomolecular pump.

**Bearings** The rotor shaft runs in two lifetime lubricated ceramic ball bearings.

**Motor** The pump is driven by a split-cage DC motor. In this motor the rotor and stator windings are separated by a vacuum-tight can. Consequently the rotor runs inside the vacuum while the stator is outside the vacuum. This eliminates any need of vacuum feedthroughs.

The pump is equipped with a temperature sensor and a resistor code.

**Cooling** Water cooling or an air cooling fan is available as optional equipment.

The intake flange should be fitted with a wire mesh inlet screen to protect the pump against mechanical damage caused by foreign objects.

**Frequency converter** The pump is driven by an electronic frequency converter TURBO.DRIVE. All functions like, for example, speed control, pump sensing or temperature monitoring are monitored by the TURBO.DRIVE. This unit is powered by an external power supply.

The TURBO.DRIVE may be installed beside or underneath the pump or up to 5 m away.

**Purge gas connection** The pumps are equipped with a purge gas facility. The purge gas and venting connection is blanked off by default with a M8 closure screw. A purge gas and venting valve may be connected either directly or by using a M8 – DN16KF adapter.

For space reasons, when the frequency converter is installed at the side, only either the air cooler or a purge gas valve can be connected.

## 1.2 Standard equipment

The pumps are shipped sealed in a PE bag with a desiccant to absorb moisture. The maximum useful life of the desiccant is one year.

The high- and forevacuum flanges are covered with protection caps.

The connection elements and the inlet screen are **not** part of the standard equipment.

A suitable DC coupling for the power supply is included: In the case of pumps with integrated frequency converter it is supplied with the pump, in the case of pumps with a separate frequency converter it is supplied with the frequency converter.

---

PE = Polyethylene

FPM = Fluororubber, resistant to temperatures up to 150°C (302 °F)

# Description

## 1.3 Technical data

### TURBOVAC

	DN 40 KF	SL 80 DN 63 ISO-K	DN 63 CF
High-vacuum connection			
Pumping speed (without inlet screen) for			
N <sub>2</sub>	on	65 l·s <sup>-1</sup>	65 l·s <sup>-1</sup>
Ar	request	60 l·s <sup>-1</sup>	60 l·s <sup>-1</sup>
He		55 l·s <sup>-1</sup>	55 l·s <sup>-1</sup>
H <sub>2</sub>		49 l·s <sup>-1</sup>	49 l·s <sup>-1</sup>
Ultimate pressure			
with two-stage, oil-sealed rotary vane pump		< 2·10 <sup>-10</sup> mbar	
with diaphragm pump		< 5·10 <sup>-9</sup> mbar	
Max. permissible forevacuum pressure with N <sub>2</sub>			
without purge gas		16 mbar	
with 0.4 mbar·l·s <sup>-1</sup> (24 sccm) purge gas		5 mbar	
Max. gas throughput with water cooling			
N <sub>2</sub>		2.0 mbar·l·s <sup>-1</sup>	
Ar		1.6 mbar·l·s <sup>-1</sup>	
H <sub>2</sub>		0.5 mbar·l·s <sup>-1</sup>	
He		1.2 mbar·l·s <sup>-1</sup>	
Weight			
Pump	1.8 kg	1.9 kg	3.1 kg
Pump with DN 63 ISO-K flange			
with TURBO.DRIVE 400		2.5 kg	
with TURBO.DRIVE 400 and air cooler		2.8 kg	
with TURBO.DRIVE 400 and water cooling		3.1 kg	
Recommended forevacuum pumps			
TRIVAC		D 2.5 E	
Diaphragm pump DIVAC		0.8 T	
Operating speed		72,000 rpm	
Run-up time		1.5 min	
Power consumption			
at run-up		120 W	
at ultimate pressure		17 W	
Forevacuum connection		DN 16 KF	
Type of protection		IP 20	
Noise level		< 46 dB(A)	
Ambient temperature			
during operation		+ 15 - + 45 °C	
storage		- 15 - + 70°C	
Max. rel. air humidity		approx. 95% <sup>1)</sup> (non-condensing)	

1) More details in Applied technical standard IEC 721-3-3  
3K3/ 3Z1/ 3B1/ 3C1/ 3S2/ 3M1

# Description

## Option water cooling

Cooling water connections	Hose nipples / G 1/8"
Cooling water data	see Section 3.6

## Option air cooling

Power consumption	0.9 W
Volume flow	20 m <sup>3</sup> /h

## TURBO.DRIVE 400

Supply voltage	24 V $\overline{\text{---}}$ ( $\pm 10\%$ )
Residual ripple	< 3 %
Output	
Voltage	0 - 24 V 3~
Power	160 W
Frequency	0 - 1500 Hz
When operating a SL 80	
Nominal voltage	24 V $\overline{\text{---}}$
Max. power consumption	140 W
Max. peak current, input side	6 A DC
Required power output from the power supply	$\geq 150$ W
Max. length of the DC cable (shielded)	
at 3 x 1.5 mm <sup>2</sup>	5 m
at 3 x 2.5 mm <sup>2</sup>	20 m
Relay output rating	42 V, 0.5 A
Ambient temperature	
during operation	5 - 45 °C
storage	- 15 - + 70 °C
Relative air humidity	5 to 85 % non condensing
Overvoltage category	II
Contamination grade	2
Temp. of the cooling surface	5 - 55 °C
For Part Nos. 800073V0004 /07	5 - 50 °C
Power consumption	$\leq 20$ W
Type of protection	IP 20
Weight, approx.	0.5 kg

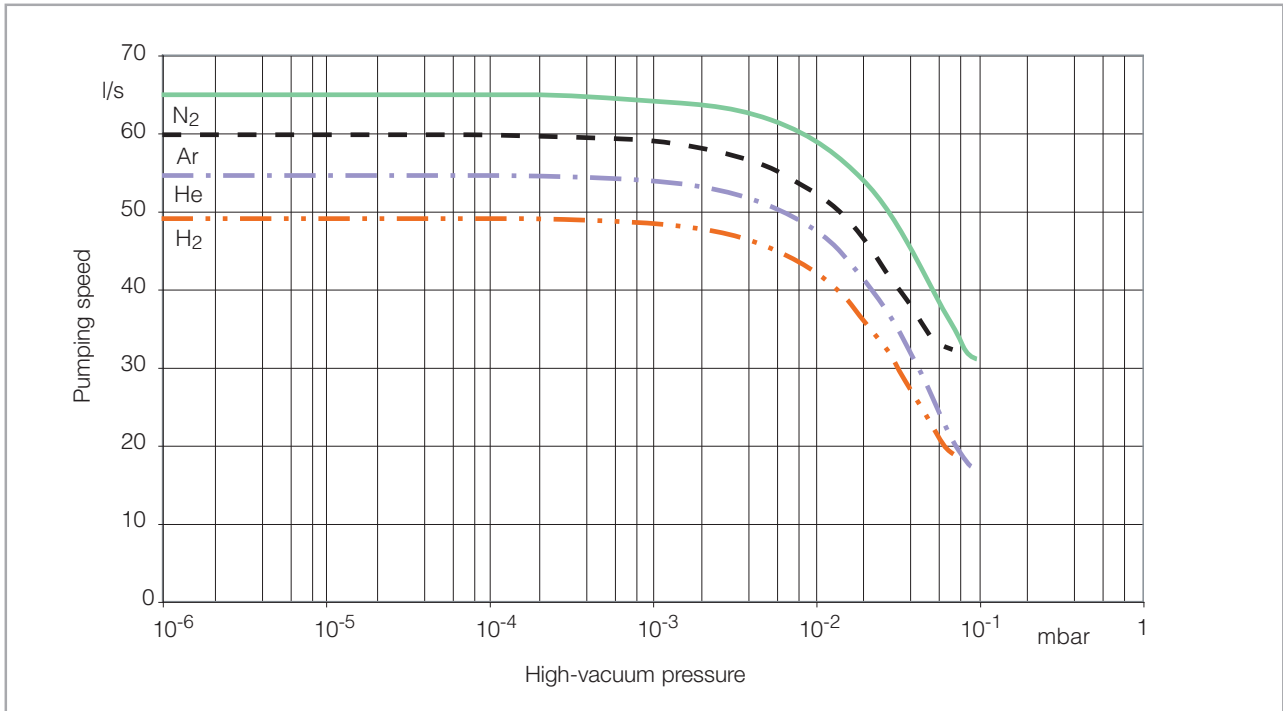

Fig. 1.2 Pumping speed curves of the SL 80

### Purge gas and venting valve

Part No.	800152V0013	800152V0014	800152V0042
Gas flow rate at 1 bar	0.4 mbar·l·s <sup>-1</sup> (24 sccm)		
Solenoid valves	2, normally closed		
Mains supply	24 V DC	230 V AC	115 V AC
Power consumption	4 W	6 W	4 W
Connection to pump	DN 10 KF		
Needed for this:			
Adapter M8 – DN10/16KF, P/N	800110V0011		
Including O-ring 9.25 x 1.78 and			
Adapter centering ring DN 10/16 KF with sinter filter			
Gas connection	G1/4-in.		
Recommended for this:			
Adapter with filter including O-ring and gasket	800110V0012		
Dimensions	60 x 65 x 45 mm	61 x 65 x 45 mm	61 x 65 x 45 mm

# Description

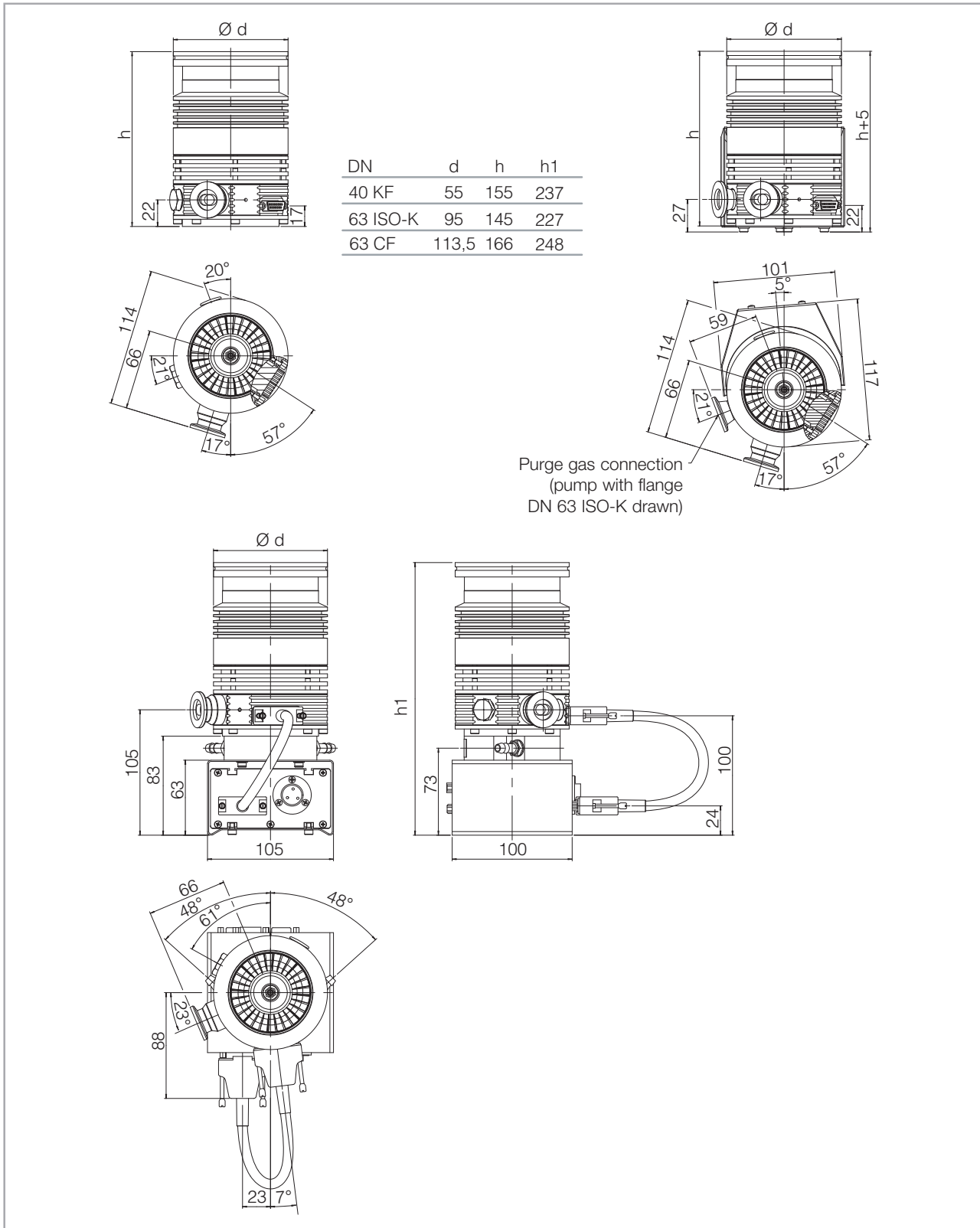

Fig. 1.3 Dimensional drawings for SL 80 pumps (combination examples); dimensions in mm

# Description

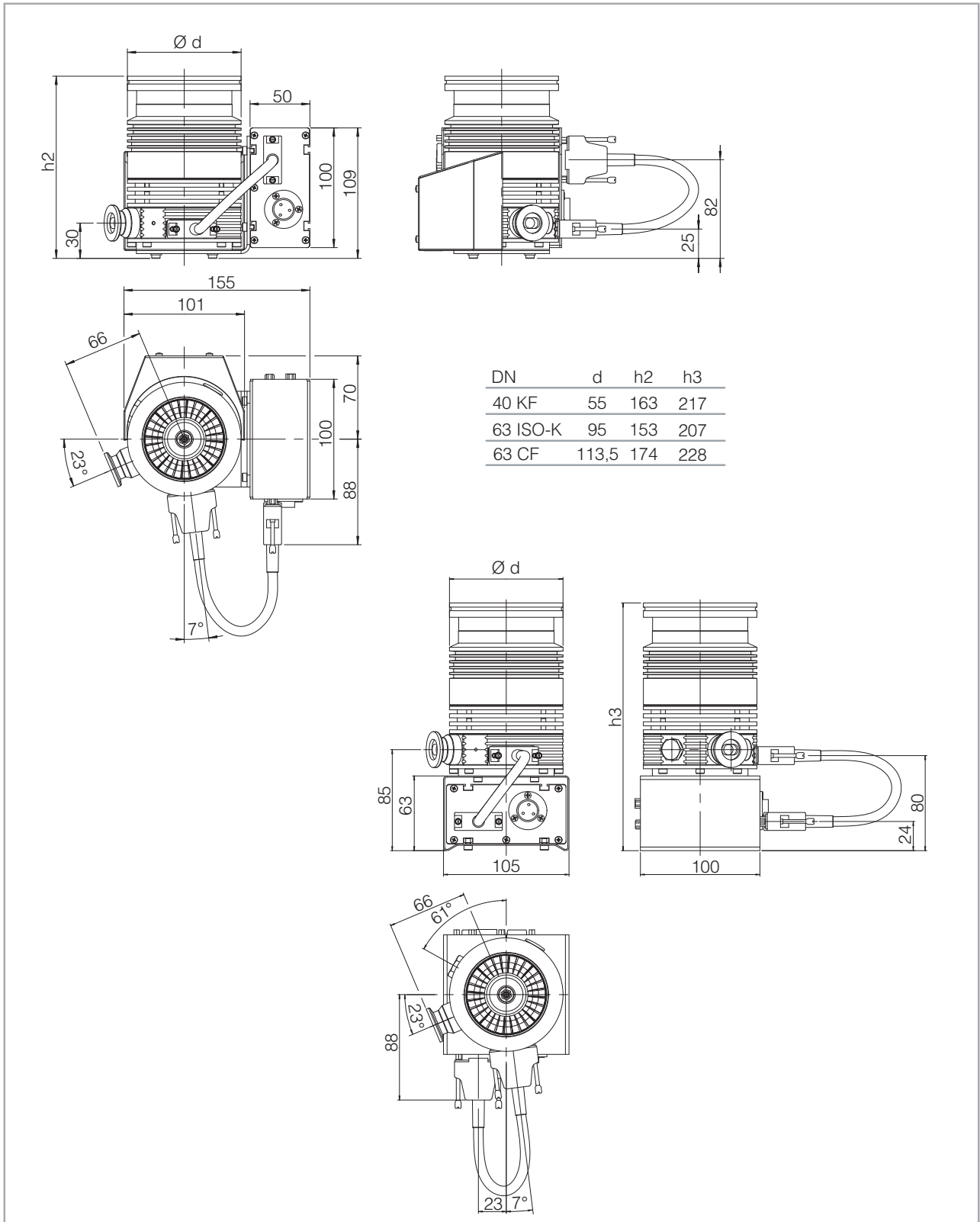

Fig. 1.4 Dimensional drawings for SL 80 pumps (combination examples); dimensions in mm

# Description

## 1.4 Ordering data

### TURBOVAC SL 80

High-vacuum flange DN 63 ISO-K  
 High-vacuum flange DN 63 CF  
 High-vacuum flange DN 63 CF-VA  
 High-vacuum flange DN 40 KF

### Part No.

800002V3001  
 800002V3002  
 800002V3003  
 800002V3004

## 1.5 Accessories

### Frequency converter TURBO.DRIVE 400

with RS 232 C interface  
 with RS 485 C interface  
 with Profibus interface

800073V0002  
 800073V0003  
 800073V0004

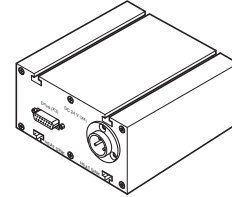

### Connecting cable pump - frequency converter

0.2 m long	800152V0021
0.3 m long	800152V0023
0.4 m long	800152V0022
1.0 m long	152 47
2.5 m long	864 49
3.0 m long	864 40
5.0 m long	864 50

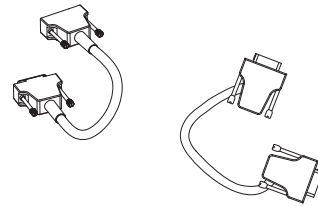

### Mounting kit TD 400 for TURBOVAC SL80

Including 0.2 m long connection cable pump - frequency converter  
 For installing the frequency converter

... beside the pump	800110V005
... underneath the pump (not for TD 400 with Ethernet/IP interface)	800110V008

Water cooling with G 1/8" connections incl. 2 hose nipples G 1/8", Outer Ø 8 mm for water hose, 2 sealing rings approx. 10x4x1 4 screws M4x20, DIN 912 4 screws M4x30, DIN 912 (for mounting the frequency converter under the pump)	800135V0001
--	-------------

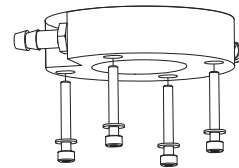

Air cooler (is powered by the pump) 4 screws M4x10, DIN 912	800136V0001
---	-------------

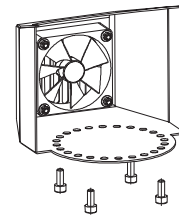



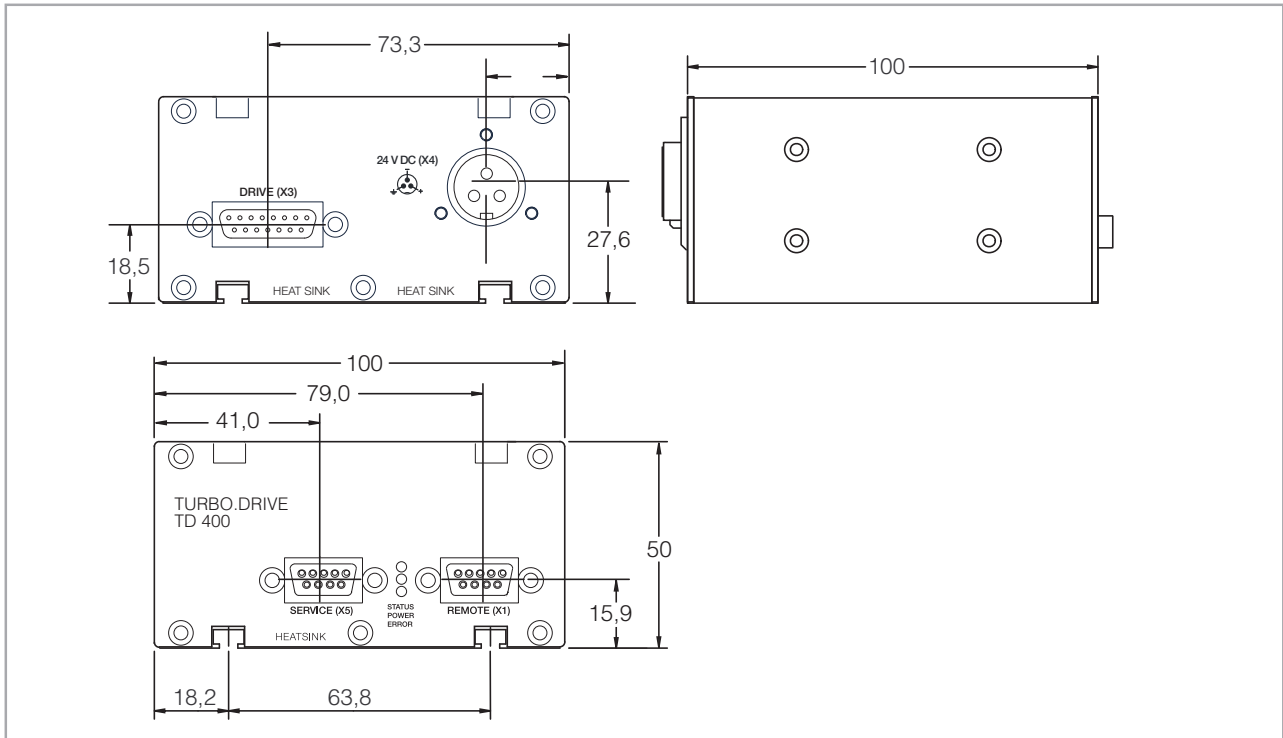

Fig. 1.5 Dimensional drawing for the frequency converter; dimensions in mm

### OEM power supply (with screw terminals)

#### SITOP 24 V / 10 A

152 50

- supplies the TURBO.DRIVE 400 with 24 V DC
- other power supplies on request

### 24 V DC cable (TURBO.DRIVE 400 – OEM power supply)

3 m	200 12 732
5 m	200 12 733
10 m	200 12 734
20 m	200 12 735



### Mains cable for power supply, 2 m long

with EURO plug	800102V0001
with US plug 5-15P	800102V1001



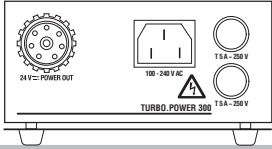
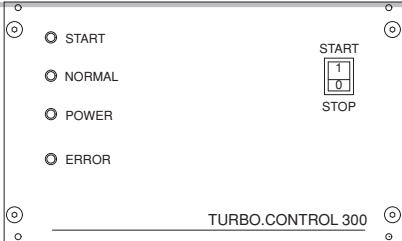
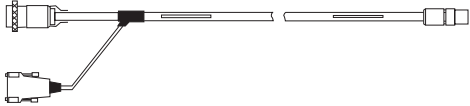

# Description

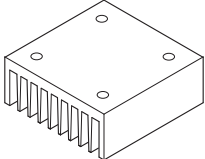
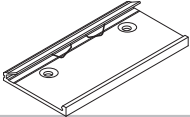
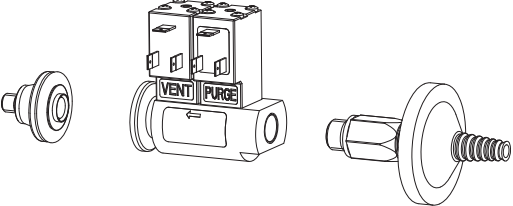
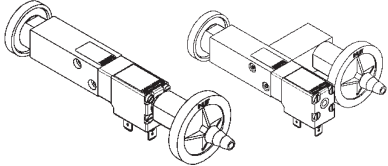
		Part No.	
<b>Power supply unit - plug and play</b> <b>TURBO.POWER 300</b> <ul style="list-style-type: none"> <li>■ supplies the TURBO.DRIVE 400 with 24 V DC</li> <li>■ plug &amp; play cables</li> <li>■ desktop unit or rack mountable</li> </ul>		800100V0002	
<b>24V DC Power cable (TURBO.DRIVE 400 – TURBO.POWER 300)</b>			
1 m		800094V0100	
3 m		800094V0300	
5 m		800094V0500	
10 m		800094V1000	
20 m		800094V2000	
<b>Mains cable for TURBO.POWER 300, 3 m long</b>			
with EURO plug		800102V0002	
with US plug 6-15P		800102V1002	
with UK plug		800102V0003	
<b>Power supply and control unit</b> <b>TURBO.CONTROL 300</b> <ul style="list-style-type: none"> <li>■ supplies the TURBO.DRIVE 400 with 24 V DC</li> <li>■ plug &amp; play cables</li> <li>■ desktop unit or rack mountable</li> <li>■ with power switch</li> <li>■ with start/stop switch for the turbomolecular pump</li> <li>■ remote control</li> <li>■ status LEDs and status relays</li> </ul>		800100V0001	
<b>24V DC Control cable (TURBO.DRIVE 400 – TURBO.CONTROL 300)</b>			
1 m		800091V0100	
3 m		800091V0300	
5 m		800091V0500	
10 m		800091V1000	
20 m		800091V2000	
<b>Mains cable for TURBO.CONTROL 300, 3 m long</b>			
with EURO plug		800102V0002	
with US plug 6-15P		800102V1002	
with UK plug		800102V0003	
PC software " <b>Turbo.Drive Server</b> " for Windows 95 and higher, CD-ROM <ul style="list-style-type: none"> <li>■ Display, change, save and compare parameter lists</li> <li>■ Integration of customer's software</li> <li>■ Record parameter data</li> </ul> <div style="text-align: right; margin-right: 100px;">800110V0102</div> The software can also be downloaded from <a href="http://www.oerlikon.com">www.oerlikon.com</a> in the menu Oerlikon Leybold Vacuum → Documentation → Download Software			
GSD file for Profibus DP Can be downloaded from <a href="http://www.oerlikon.com">www.oerlikon.com</a> in the menu Oerlikon Leybold Vacuum → Documentation → Download Software			

# Description

		Part No.	
<b>Mechanical accessories</b>			
Plug for connector REMOTE with integrated <b>ON/OFF switch</b> for the pump (Sub-D plug, 9 way)	152 48		
Heat sink for frequency converter	800110V0001		
<b>Top hat rail adaptor</b> (mounting aid for TURBO.DRIVE 400 and TURBO.POWER 300)	800110V0003		
<b>Purge gas and venting valve</b> 0.4 mbar-l/s at 1 bar			
24 V DC	800152V0013		
230 V AC	800152V0014		
115 V AC	800152V0042		
DN 10 KF – G <sup>1</sup> / <sub>4</sub> "			
Pump connection: Adapter M8 – DN-16-KF incl. O-ring 9.25 x 1.78 and Adapter centering ring DN 10/16 KF with sinter filter	800110V0011		
Gas side connection: G1/4-in. adapter with filter Including O-ring and gasket	800110V0012		
Venting valve 24 V DC	800120V0011		
Power failure venting valve 24 V DC	800120V0021		
Spare filter	E 200 18 517		

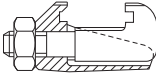
# Description

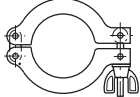
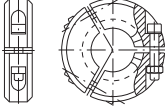
	<b>Part No.</b>	
inlet screen		
DN 40 KF	E 200 17 169	
DN 63 ISO-K	E 200 17 170	
DN 63 CF	E 200 17 171	
Flange heater (only for pumps with CF flange)		
DN 63 CF, 230 V	854 04	
DN 63 CF, 110 V	854 07	
Copper gasket rings for CF flange (Set of 10 pieces)		
DN 63 CF	839 44	
Set of hex. screws with nuts, screws and washers for CF flange DN 63 CF	838 81	
Centering ring (Al) with O-ring (FPM)		
DN 63 ISO-K	268 41	
Clamps (Set of 4 pieces)	267 01	
Centering ring with O-ring for DN 16 KF		
Al/CR	183 26	
Al/FPM	182 06	
Clamping ring (Al) DN 16 KF	183 41	
Clamping Collar DN 40 KF for Ultra Sealing Rings	882 78	

# Transport and storing

## 2 Transport and storing

Remove the equipment from the transportation box and keep the packaging. Make sure that the product has not been damaged during transportation. If this unit is damaged contact your carrier and inform Oerlikon Leybold Vacuum if necessary. For storage of the product, use the packaging provided.

Be careful not to damage the sockets and connections during transportation.

Do not stand below the pump while connecting or removing the turbomolecular pump.

The turbomolecular pump is shipped in a sealed PE bag with desiccant. Do not open the sealed package until immediately before installing.

Do not remove the covers and blanking flanges until you are ready to make the connections, to ensure that the turbomolecular pump is installed under the cleanest possible conditions.

Turbomolecular pumps which were not operated for a period of over 12 months should be returned to us. For more information on this please contact your local sales partner.

Do not store pump and accessories in a moist atmosphere so as to prevent these items from suffering corrosion.

### Keep the packaging

---

#### NOTICE



---

#### CAUTION



# Installation

## 3 Installation

### 3.1 Conforming utilization

The turbomolecular pump is intended for generating a vacuum. It is suited for non-corrosive processes only.

The turbomolecular pump must be bolted to a rigid vacuum system and connected to a suitable backing pump.

The turbomolecular pump must only be operated with correspondingly specified frequency converters, the special connecting cables and mounting bolts.

Both pump and frequency converter are intended for being operated within closed rooms.

The use of any accessories which have not been specified by Oerlikon Leybold Vacuum is only allowed after approval by Oerlikon Leybold Vacuum.

#### 3.1.1 Non-conforming utilization

Non-conforming utilizations for both pump and frequency converter are among others:

- Pumping of gases and vapours for which the materials of the pump are unsuitable.
- Operation in connection with processes in which GaAs (gallium arsenide) is being pumped.
- Pumping of gas mixtures with an oxygen content of > 21%.
- Pumping of corrosive gases and dust containing gases without reverting to purge gas operation.
- Pumping of condensable vapours without suitably controlling the temperature of the pump. Upon compression within the pump, these vapours may condense or form deposits.
- Pumping of dusts and solids without the use of suitable screens and filters.
- Operation at an inadmissibly high forevacuum pressure.
- Operation at inadmissibly high gas loads.
- Utilization of both pump and frequency converter in explosion hazard areas.
- Non-compliance of the specified maintenance and servicing intervals for both pump and frequency converter.
- Operation of the pump and drive electronics in environments which demand protection type IP 20 or higher and where the installation site is over 1000 m above sea level.
- Utilization in systems and pump systems in which the pressure may exceed 1.4 bar abs.
- Operation with an inadequately mounted pump.

- Operation without having flanged the pump to the system or without having connected it to a suitable backing pump.
- Operation with additional heat sources involving thermal radiation, thermal conduction via the high vacuum or the forevacuum flange, strong magnetic fields or very hot process gases, for example.
- Use in systems in which impact stress and vibrations or periodically occurring forces affect pump, frequency converter and cables.
- Operation on moving system or system components (locks or movable pump systems, for example).
- Operation at vibration absorbers and vacuum components (gate valves, valves) which are not capable of sustaining the specified deceleration torque should the pump rotor seize.
- Stepping on pump, add-on parts, drive electronics, flanges and cables to climb onto the system.
- Fitting of add-on parts to the forevacuum flange which cause an inadmissible high load.
- Removing, covering or obstructing warning notices.
- Standstill or storing of pump and drive electronics without suitable sealing-off and drying. Storing in a humid atmosphere can cause corrosion.
- Conversions, manipulations and maintenance work by personnel not authorised by Oerlikon Leybold Vacuum.

Any non-conforming utilisation of pump, frequency converter and accessories can result in severe injury and cause damage to components.

---

**WARNING**



# Installation

## 3.2 Operating environment

- Ambient temperature** The maximum permissible ambient temperature is 45 °C (113 °F). Do not expose the pump or the frequency converter to dripping or spraying water.
- Magnetic field** If the pump is used within a magnetic field, the magnetic induction at the surface of the pump housing may not exceed:  
B = 5 mT if impinging radially and  
B = 15 mT if impinging axially.  
Install shielding equipment as appropriate if these values are exceeded.
- Radiation** The standard pump version without frequency converter is resistant to radiation up to 10<sup>3</sup> Gy.
- Places of installation** Places of installation up to 1000 m above sea level (3300 ft) are possible without restrictions. At altitudes over 1000 m heat dissipation by the ambient air is impaired. Please consult us.  
The frequency converter must not be operated in explosive gas atmospheres.

---

1 mT (milliTesla) = 10 G (Gauß)

1 Gy (Gray) = 100 rad



### 3.3 Fitting accessories

Either a water or air cooling facility and a purge gas and venting valve can be fitted to the pump.

Moreover, the frequency converter may be fitted beside or underneath the pump.

For space reasons, when the frequency converter is installed at the side, only either the air-cooler or a purge gas valve can be connected.

See Fig. 3.1 and 3.2

When fitting the accessories note the following:

- For fitting, place the pump **with the protection cap in place** on its high vacuum flange.
- In the case of bolts which are screwed into the bottom of the pump, use the washers. Otherwise the bolts may possibly be too long.
- The stop plate serves as a mounting aid. With it, the sliding nuts can be moved to their correct position.
- The attached parts may, provided flanges and plugs are not in the way, be fitted in 15° increments as required.
- When fitting as shown in the figures, the 0.2 m long cable will do for the frequency converter. When the power supply connector shall point in the other direction, then the 0.4 m long cable will be needed.
- Insert the connecting cable from the air cooler into the air cooler socket. When fitting, be sure not to pinch the cable.
- As the purge gas and venting valve use either valves with a M8 screw-in thread or screw in the M8 – DN16KF adapter and connect the valve to it. See also Section 3.7.

# Installation

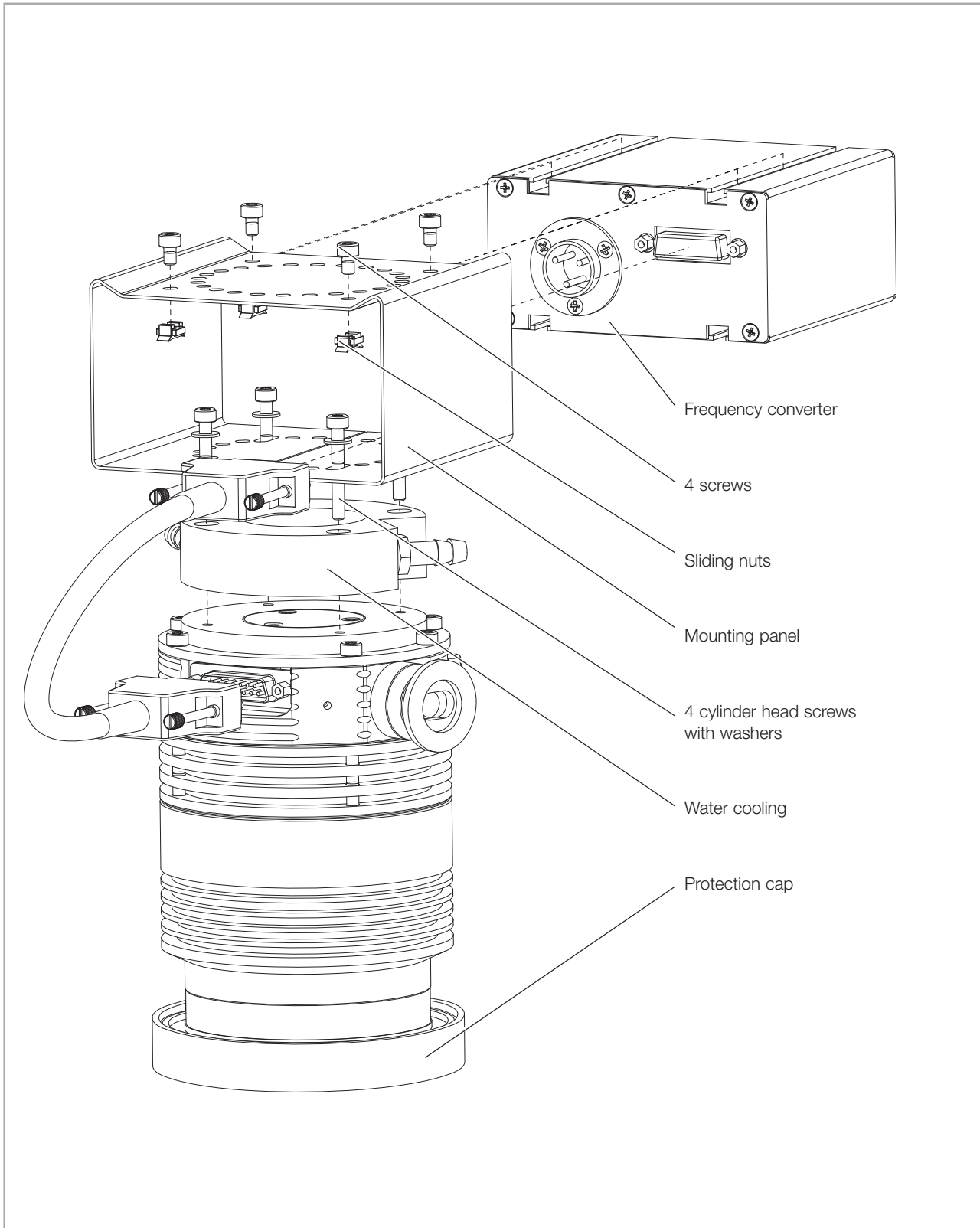

Fig. 3.1 Mounting water cooling and frequency converter underneath the pump

# Installation

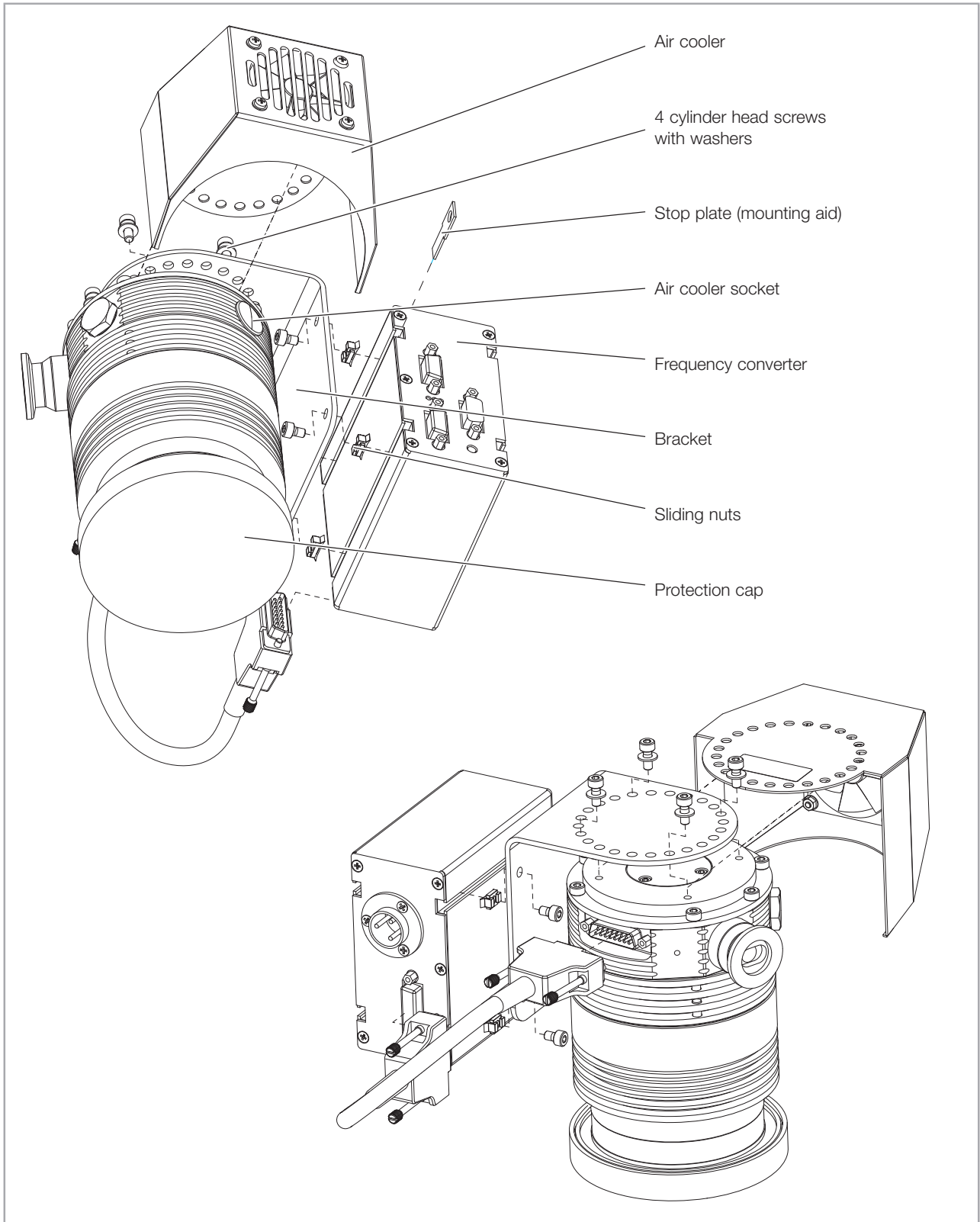

Fig. 3.2 Mounting air cooling and frequency converter beside the pump

# Installation

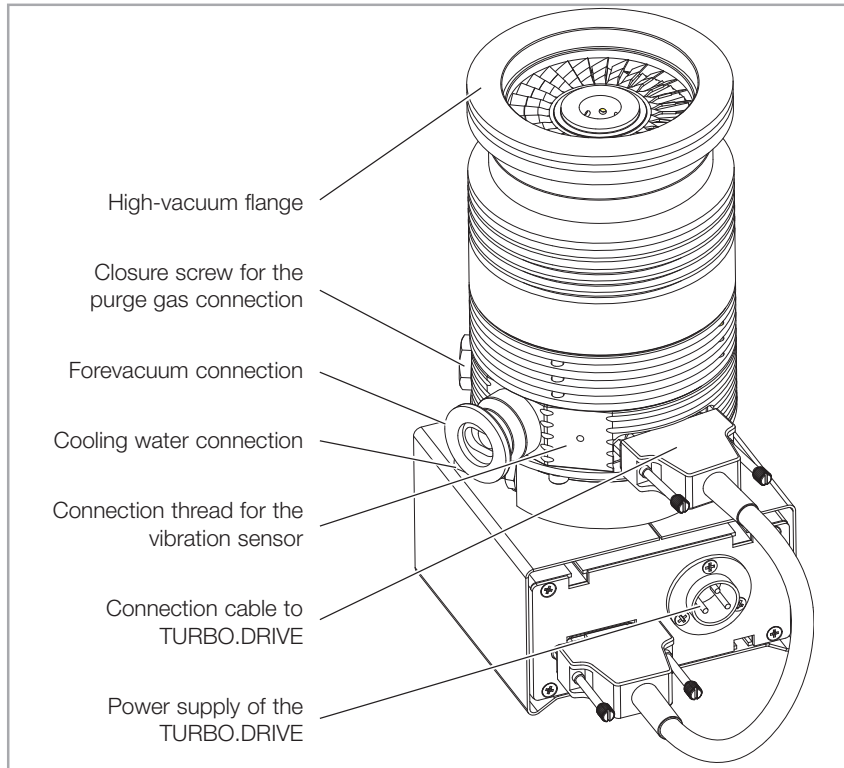

Fig. 3.3 Connection elements

---

## NOTICE



Never touch the rotor. Touching the rotor may cause injury and damage the rotor bearing.

---

## WARNING



The high-vacuum flange must be solidly mounted to the vacuum chamber. Observe Safety Information 0.1.6.

---

## Torque when the rotor seizes

Remove the transport seal from the intake flange and remove the desiccant. Pay attention to maximum cleanliness when connecting.

If the pump should suddenly seize, an ensuing deceleration torque of up to 175 Nm will have to be absorbed by the system.

In most applications the pump is flanged to the high-vacuum flange at the apparatus. The pump can be mounted and operated in any desired attitude.

No support is required. If nonetheless an additional fastening is requested you can use the 4 boreholes in the pump's bottom.

Use exclusively flange connecting components and fittings which have been manufactured in accordance with DIN 28403, DIN 28404, ISO 1609 (KF- and ISO-K flange connections) or ISO 3669 (CF flange connections).

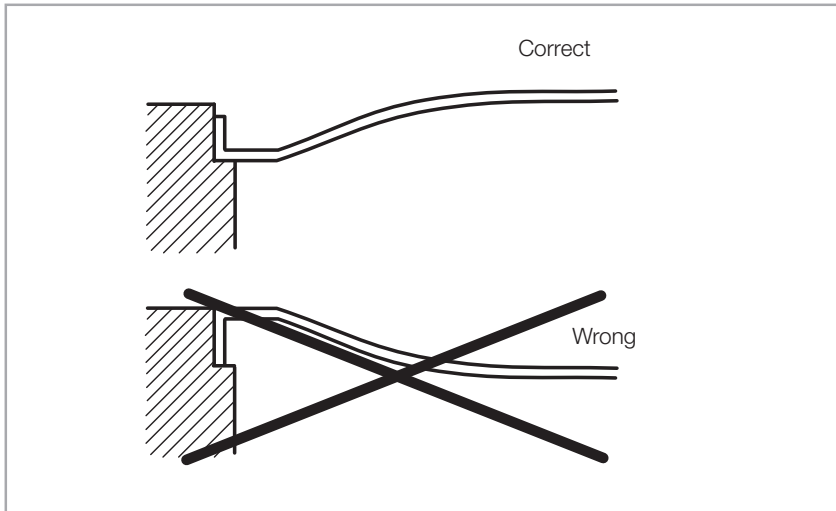

Fig. 3.4 Installing the inlet screen

The flange material to which the pump is bolted, must have at operating temperature a minimum strength specification of  $150 \text{ N/mm}^2$ .

### Operation with vibration absorber

The pump is precision balanced and is generally operated without a resonance damper. To decouple extremely sensitive equipment and to prevent transfer of external vibrations to the pump a special resonance damper is available for mounting at the high-vacuum flange.

In this case mount the turbomolecular pump separately. A vibration absorber cannot reliably sustain the high deceleration torque in case of a rotor seizure.

If additional mounting is not possible, then the pump must be protected by a suitable shield during operation.

Besides the forevacuum connection it is possible to connect a vibration sensor: thread M3, 9.3 mm deep.

If several turbomolecular pumps are installed to the vacuum chamber of the same system, there is the risk of interference (vibration interference between the pumps). If such a risk exists please contact Oerlikon Leybold Vacuum Application Support.

The standard mounting arrangement for the pump is adequate to ensure earthquake protection. If required mount the system to the floor or the walls.

### Vibration influence

### Earthquake protection

# Installation

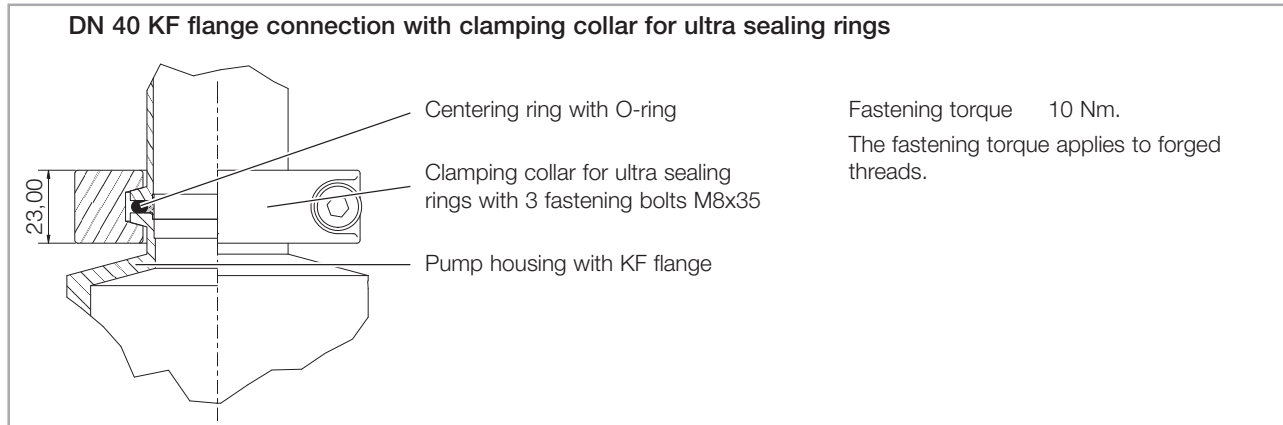

Fig. 3.5 Mounting the DN 40 KF high vacuum flange

---

## NOTICE



### Install an inlet screen

Foreign objects which enter the pump through the intake would cause serious damage to the rotor. That's why we recommend installing an inlet screen. Damages caused during operation without the inlet screen are excluded from warranty.

Insert the inlet screen so that the surface curvature is at the top and apply some pressure lightly at the rim so that the inlet screen engages, see Fig. 3.4.

If dust could pass from the vacuum chamber into the pump, then a micropore filter must be installed between the vacuum chamber and the pump.

### Flange mounting for KF flanges

When flanging on the high vacuum connecting flange, place the O-ring on the centering ring. The O-ring must remain in place smooth and untwisted.

When using an ultra sealing ring, always use an outer support ring.

---

## NOTICE



The contact surfaces of pump housing, vacuum system and centering ring must be free of grease and dry so as to ensure adequate strength in case the rotor should seize.

Apply to the inner clamping surfaces of the clamping ring elements a suitable lubricant, LITHELEN vacuum grease, for example.

Only the clamping collar for ultra sealing rings as depicted in the figure may be used. A standard clamping collar is not capable of exerting the necessary press-on force and should the rotor suddenly seize, the pump may twist.

Mount the turbomolecular pump according to Fig. 3.5 and tighten the three bolts of the clamping collar step-by-step.

The KF connector for the high-vacuum flange is not strong enough to keep the pump from rotating if it should suddenly seize. Rotation of the pump can cause leaks in the forevacuum line. Secure the pump additionally to prevent rotation in case it should suddenly seize.

---

**CAUTION****Flange mounting for ISO-K flanges**

When flanging on the high vacuum connecting flange, place the O-ring on the centering ring. The O-ring must remain in place smooth and untwisted. Thereafter put the outer ring in place.

Mount the turbomolecular pump according to Fig 3.6 and tighten the bolts crosswise step-by-step.

When using an ultra sealing ring, always use an outer support ring. The information on the number of bolts and clamps also applies to the ultra sealing rings.

The contact surfaces of pump housing, vacuum system and centering ring must be free of grease and dry so as to ensure adequate strength in case the rotor should seize.

---

**NOTICE****Flange mounting for CF flanges**

Before fitting, check to ensure that the sealing edge is undamaged. Do not touch the copper gasket and the sealing edge with your bare hands.

The contact surfaces of pump housing, vacuum system and centering ring must be free of grease and dry so as to ensure adequate strength in case the rotor should seize.

---

**NOTICE**

Mount the turbomolecular pump according to Fig 3.7 and tighten the bolts crosswise step-by-step.

When the pump shall be baked out, the threads of the bolts should have been lubricated with a high temperature lubricant.

Owing to the deformation of the copper gasket, the fastening torque of all bolts must be checked once more after having completed the installation work.

During operation the pump can get so hot that there is the risk of suffering burns (up to approximately 80 °C). Protect the hot parts against being touched.

---

**CAUTION**

# Installation

## Flange DN 63 ISO-K at ISO-K flange

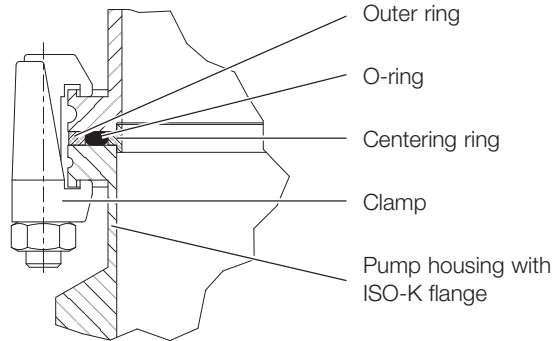

Number of clamps 4x M10  
 Minimum clamp strength yield strength > 450 N/mm<sup>2</sup>  
 Fastening torque 20<sup>+3</sup> Nm

**The fastening torque levels apply to lubricated threads.**

## Flange DN 63 ISO-K at ISO-K flange with collar flange

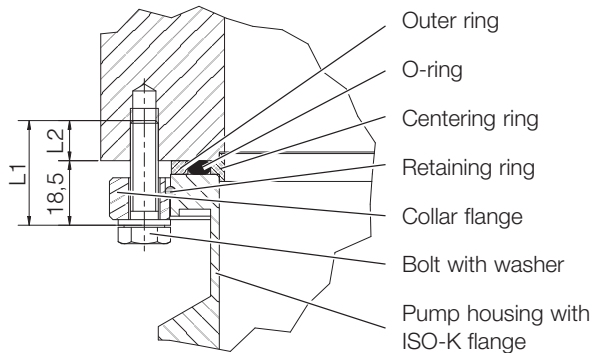

Number of bolts 4 x M8  
 Minimum bolt strength yield strength > 450 N/mm<sup>2</sup>  
 Minimum screw-in depth L2 12 mm for steel  
 16 mm for aluminium

Recommended bolts  
 for steel flanges M8x30 – ISO 4014  
 for alum. flanges M8x35 – ISO 4014

Bolt quality 8.8 or stainless steel bolts A2(A4)-70  
 Fastening torque 20<sup>+3</sup> Nm

## Flange DN 63 ISO-K at ISO-F flange with claws

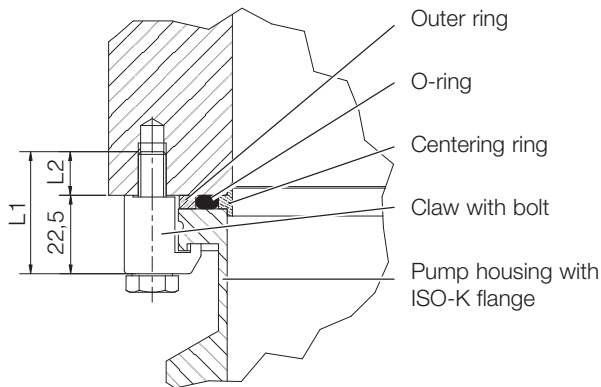

Number of claws 4 x M8  
 Minimum strength for bolt and claw yield strength > 450 N/mm<sup>2</sup>  
 Minimum screw-in depth L2 12 mm for steel  
 16 mm for aluminium

Recommended bolts  
 for steel flanges M8x35 – ISO 4014  
 for alum. flanges M8x40 – ISO 4014

Bolt quality 8.8 or stainless steel bolts A2(A4)-70  
 Fastening torque 20<sup>+3</sup> Nm

Fig. 3.6 Mounting the DN 63 ISO-K flange



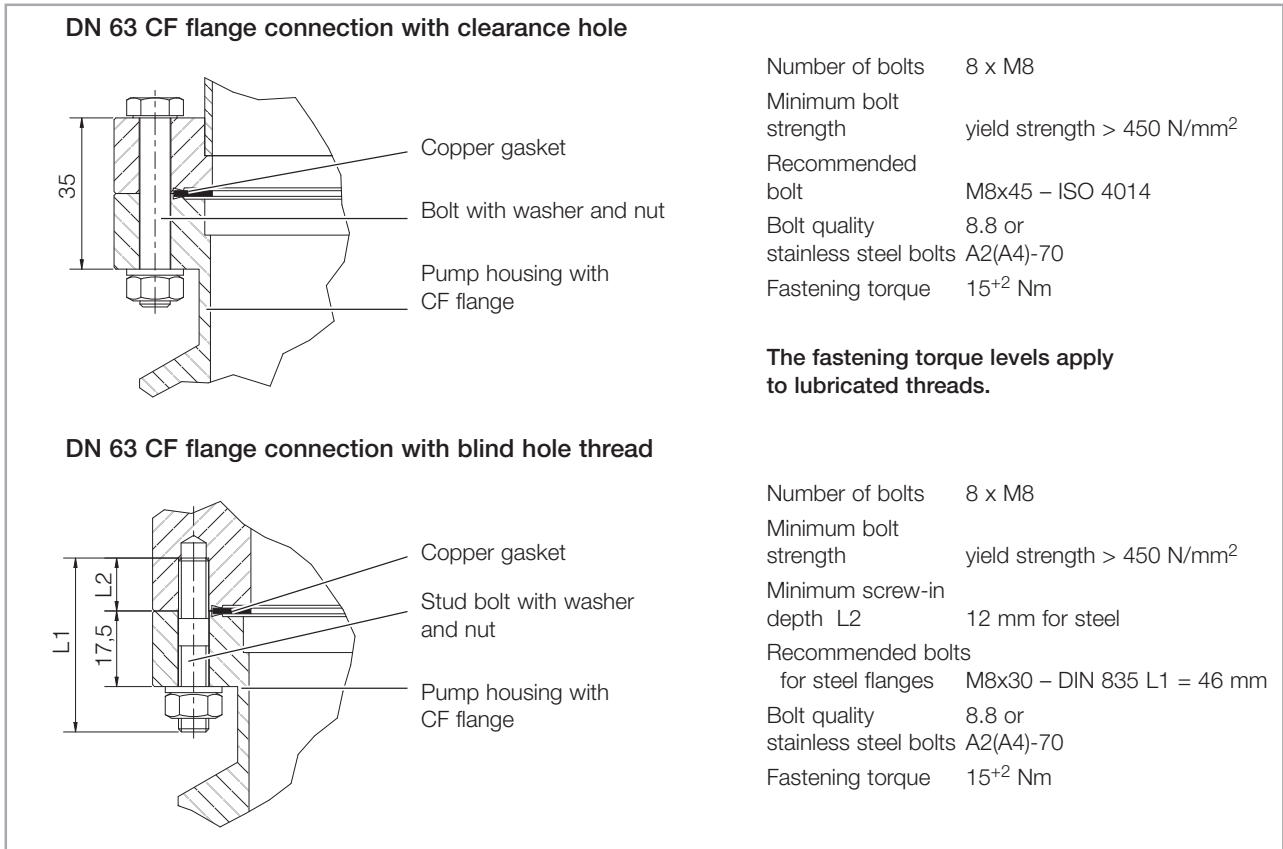

Fig. 3.7 Mounting the DN 63 CF high vacuum flange

# Installation

## Forevacuum pump

### 3.5 Forevacuum connection

The high vacuum pressure level which can be achieved is a function of the volume of gas flow  $Q$  to be pumped and the forevacuum pressure.

We recommend using dry-running diaphragm vacuum pumps or TRIVAC rotary vane pumps for this purpose.

Connect the clean forevacuum line. The connecting flanges must be clean and undamaged. The cross section of this line must be so wide that safe operation of the pump can be ensured.

---

## DANGER



The forevacuum line must be tight. Hazardous gases can escape at leaks or the gases being pumped can react with air or humidity. Observe Safety Information 0.4.5.

Fig. 3.14 is a schematic diagram of a pump system incorporating a turbomolecular pump and a TRIVAC forevacuum pump with an anti-suckback valve.

## Safety valve

A separate safety valve must be provided for oil-sealed forevacuum pumps without an anti-suckback valve. The safety valve prevents oil flowing back from the forevacuum pump into the turbomolecular pump when the system is not running.

## Adsorption trap

To ensure that the forevacuum space at the turbomolecular pump is kept largely free of oil vapors during operation, as well, we recommend installing an adsorption trap in the forevacuum line. Alternatively purge the forevacuum line with inert gas. In this case the pressure in the forevacuum line must be over  $10^{-2}$  mbar.

Provide a roughing line to achieve the shortest cycle times.

Ensure that the pump is sufficiently isolated against vibrations generated by the forevacuum pump.

No forces from the piping system may be allowed to affect the turbomolecular pump. Support the piping correspondingly or decouple through flexible joints.

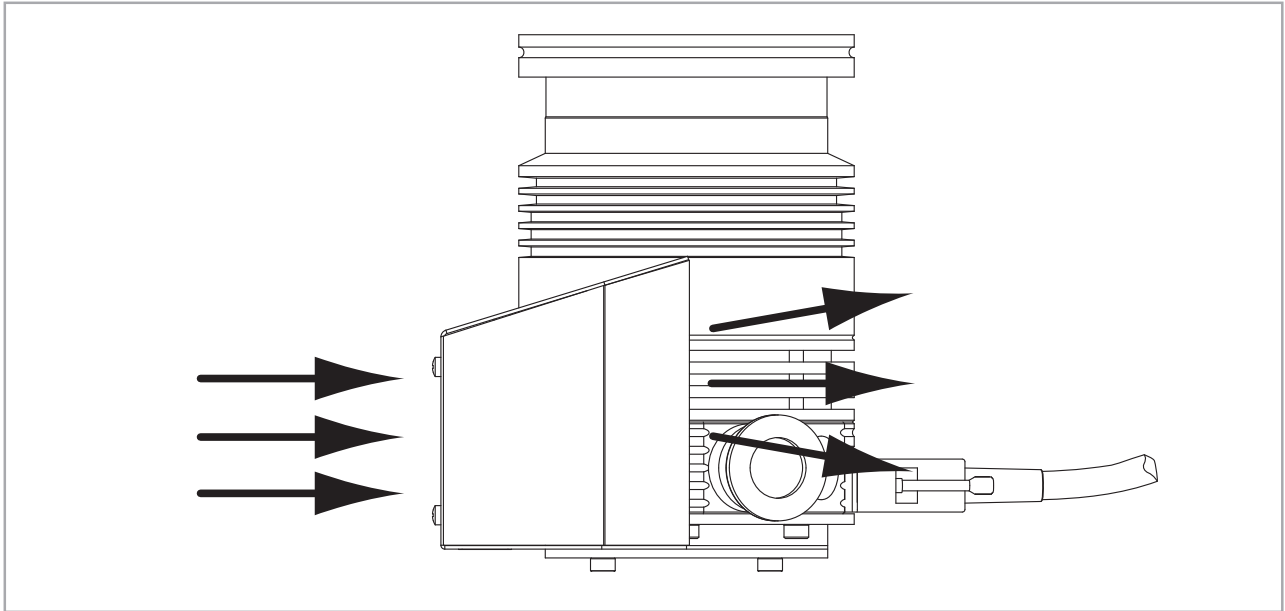

Fig. 3.8 Pump with air cooling

### 3.6 Connect the cooling

Cooling of the pump depends on the required pumping power and the ambient temperature. When the pump is insufficiently cooled it will shut down.

High gas throughputs, cyclic operation or high ambient temperatures will necessitate air or water cooling.

Air or water cooling can be mounted to the pump.; see Section 3.3, Part Nos. see Section 1.5.

The pump must be operated with the air cooling unless you have an agreement from Oerlikon Leybold Vacuum for different operation.

---

#### NOTICE



#### Air cooling

When installing air cooled pumps within a system ensure that sufficient quantities of fresh air are freely available. The air cooling facility is powered via the pump.

# Installation

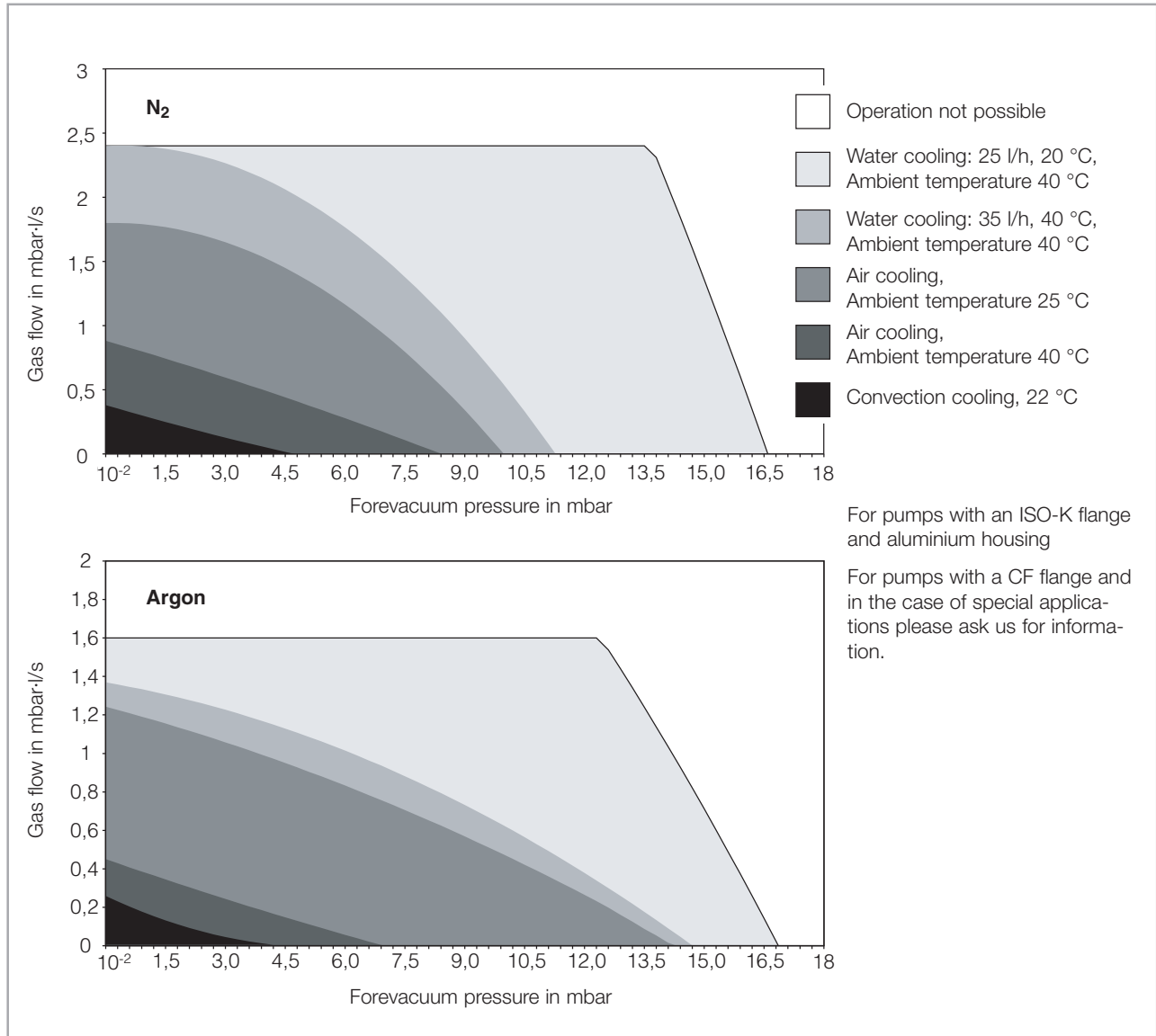

Fig. 3.9 Cooling requirements of the SL 80

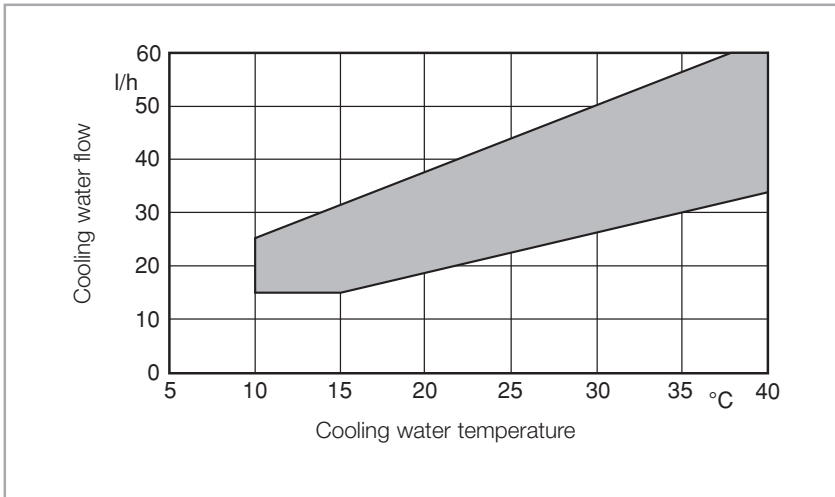

Fig. 3.10 Cooling water requirements

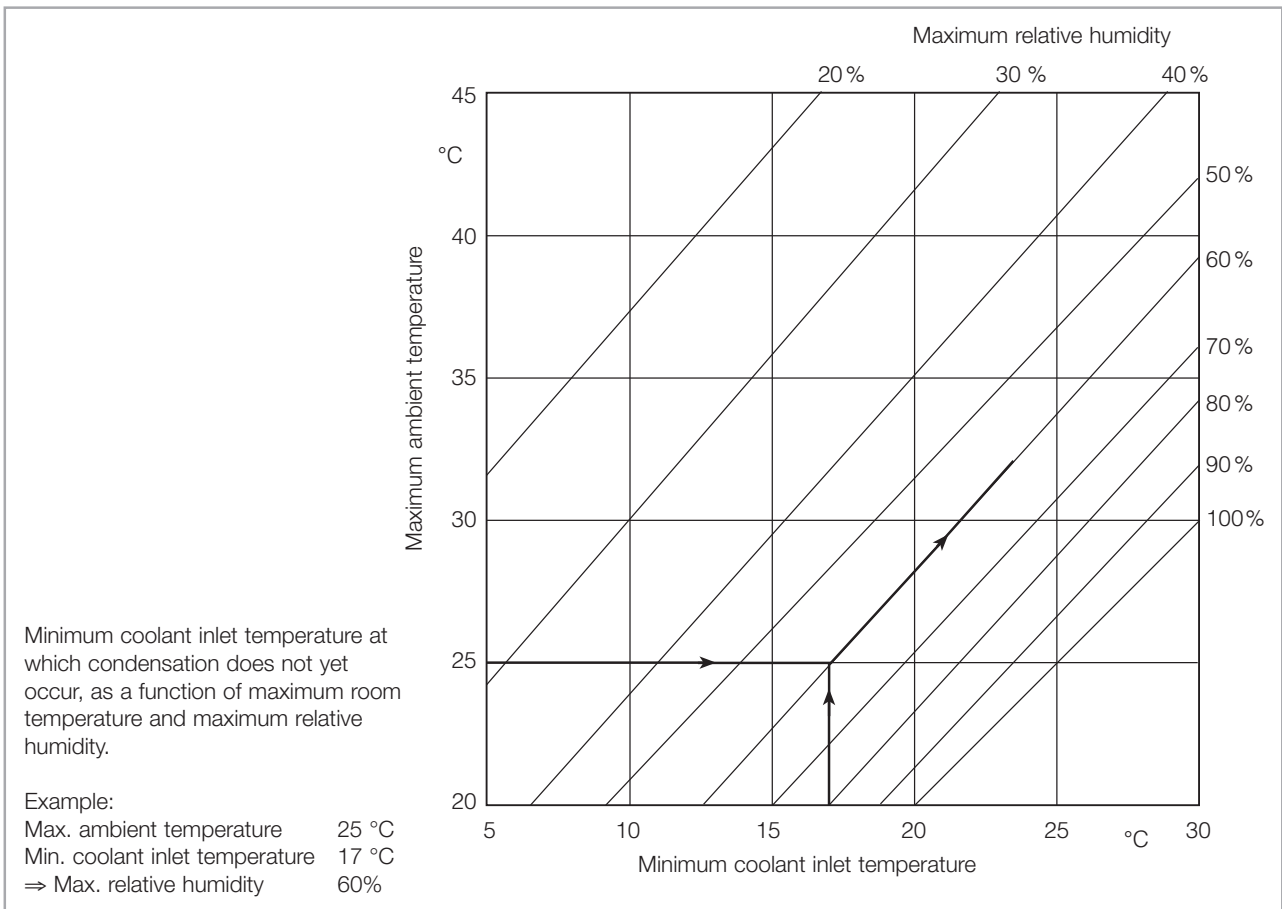

Fig. 3.11 Dewpoint diagram

# Installation

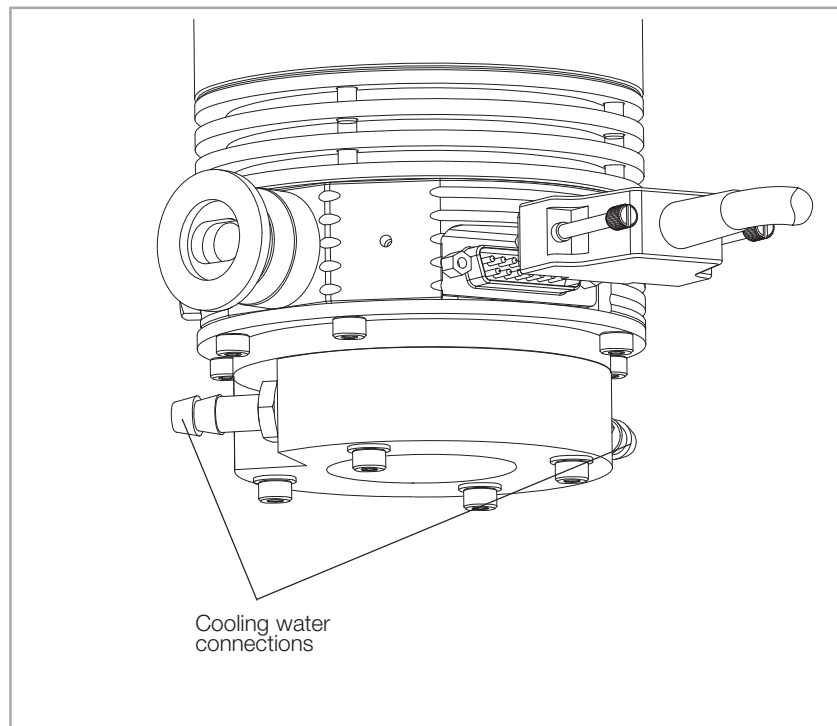

Fig. 3.12 Pump with water cooling

## Cooling water specifications

Feed temperature	10 - 40 °C
Feed pressure	2 to 7 bar absolute
Cooling water requirement	See Fig. 3.10
Appearance	colourless, clear, free of oils and greases
Sediments	< 250 mg/l
Particle size	< 150 µm
pH value	7 to 8.5
Overall hardness (total alkaline earths)	max. 20 ° German hardness scale (= 3.57 mmol/l)

## Connecting the cooling water

Connect the cooling water hoses to the hose nozzles and secure them in place with hose clamps. Alternatively the hose nozzles can be screwed out; then the G 1/8-in. connections will be accessible.

When switching the cooling water supply on and off by means of an electrically actuated valve, connect the valve so that it will be switched on and off together with the pump.

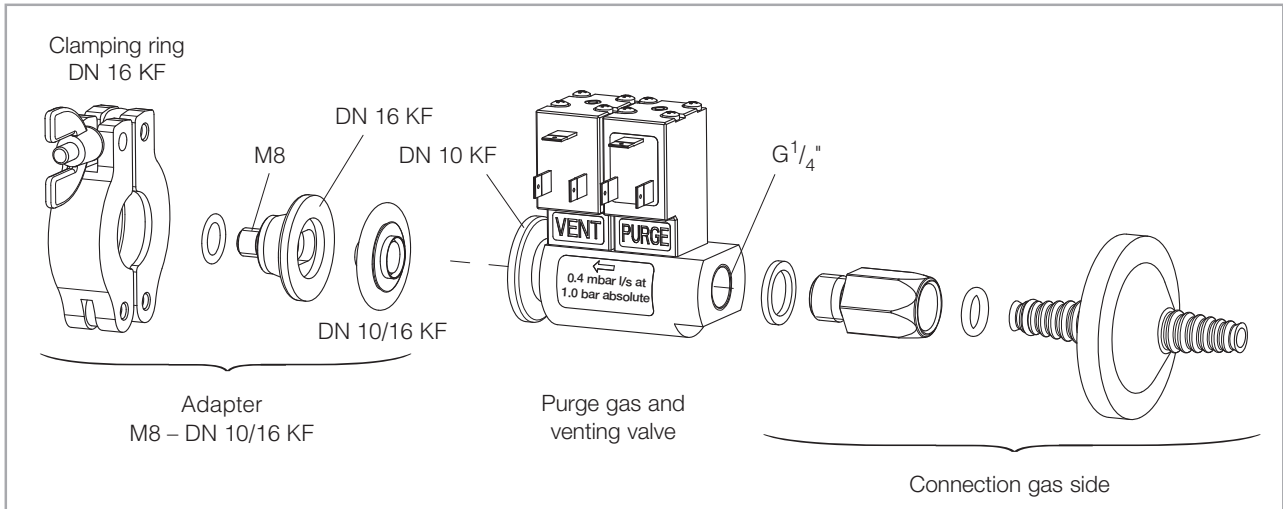

Fig. 3.13 Connecting the purge gas and venting valve

### 3.7 Connect purge gas or a venting valve

The pumps are equipped with a purge gas facility. The purge gas and venting connection has been blanked off as a standard with a M8 closure screw. A purge gas and venting valve or a power failure venting valve or a venting valve may be either connected directly or using a M8 – DN16KF adapter.

The power failure venting valve or venting valve vents the pump and the forevacuum line when the pump is switched off and thus keeps oil vapor from diffusing back from the forevacuum line.

A choke nozzle in the vent port ensures that the pump is not vented too fast.

When having to decide which gases need or not need to be pumped with purge gas we are available to provide assistance.

Refer to Section 4.1 for suited gases.

When operating the pump with purge gas, the pump needs to be vented via the purge gas valve after having shut down the pump, see Section 4.5.

Consider the additional purge gas flow when selecting a suitable backing pump.

We recommend a purge gas flow of 0.4 mbar-l/s (24 sccm) with Nitrogen.

The pressure in the pump must not exceed 1400 mbar (0.4 bar overpressure). Observe Safety Informations 0.1.2 to 0.1.5.

#### WARNING



# Installation

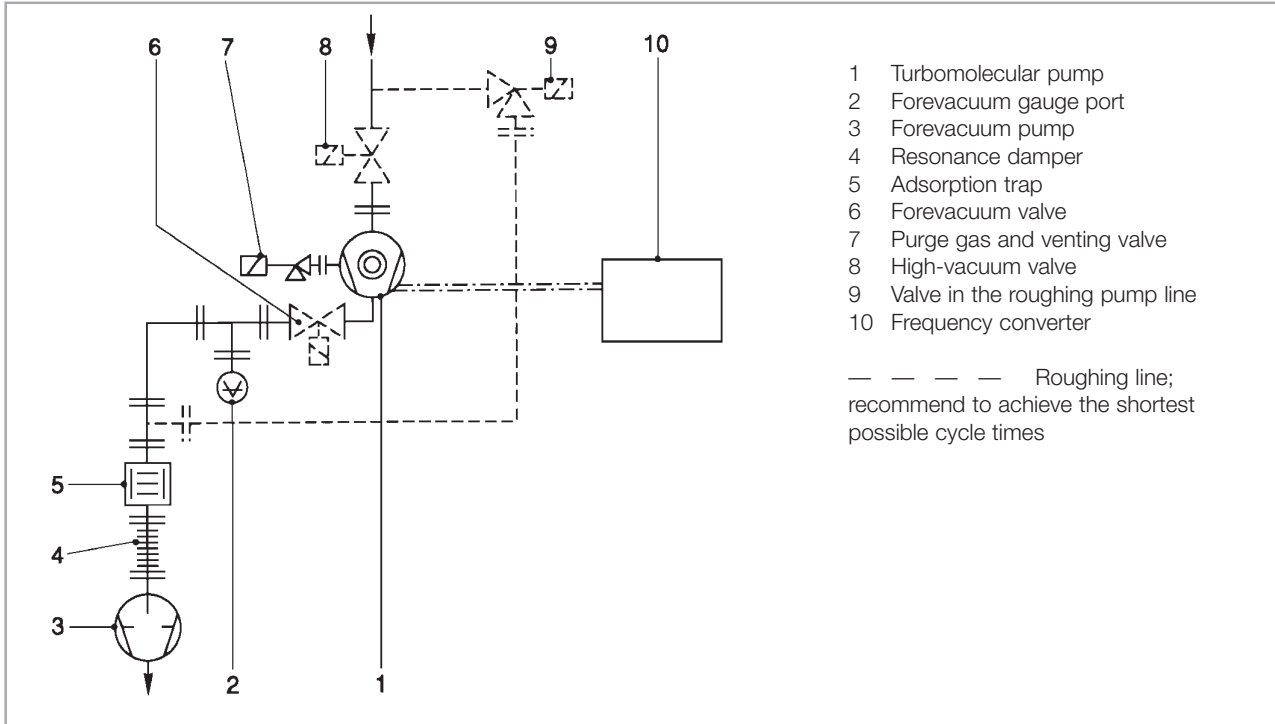

Fig. 3.14 Schematic of a turbomolecular pump system

## 3.8 Electrical connection

The TURBO.DRIVE 400 frequency converter needed to operate the TURBO-VAC SL 80 has either been integrated in the pump or is a separate unit. For connection examples see Fig. 3.15 and 3.16.

### WARNING



Observe Safety Informations 0.2.

### NOTICE



Disconnect and connect the cable connections only while the pump is turning no longer (green status LED off) **and** with the mains power switched off (yellow power LED off). Otherwise there is the risk of damaging the frequency converter.

### 3.8.1 Connecting pump and frequency converter

Connect the pump to the frequency converter using a suitable connecting cable (15 way Sub-D plug X3). Connect the Sub-D-plugs with the hexagon threaded bolts UNC 4/40x6 at the pump connector.

Make sure that the frequency converter is adequately cooled; for this see Section 3.8.3 and also Fig. 3.18.



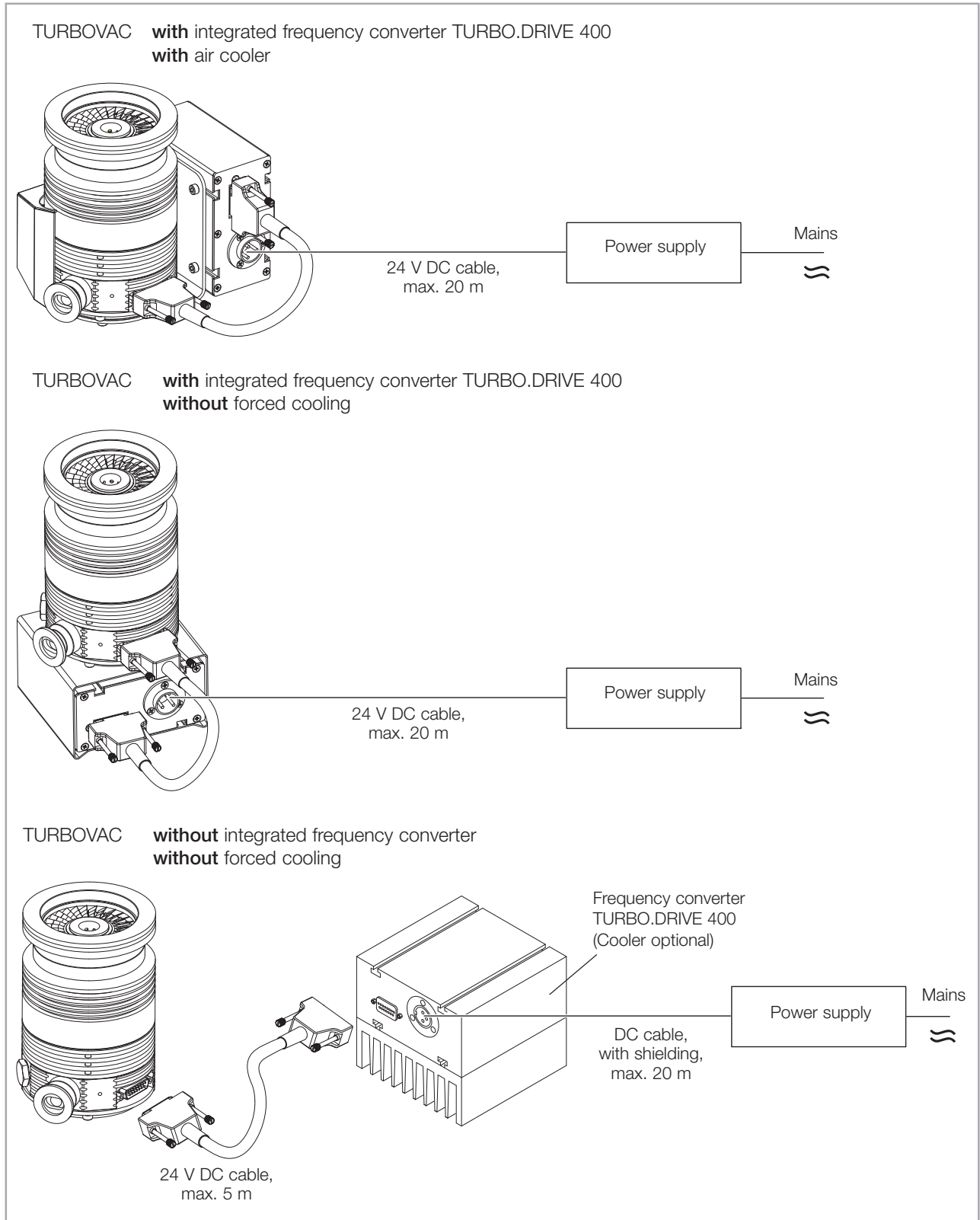

Fig. 3.15 Examples for connection

# Installation

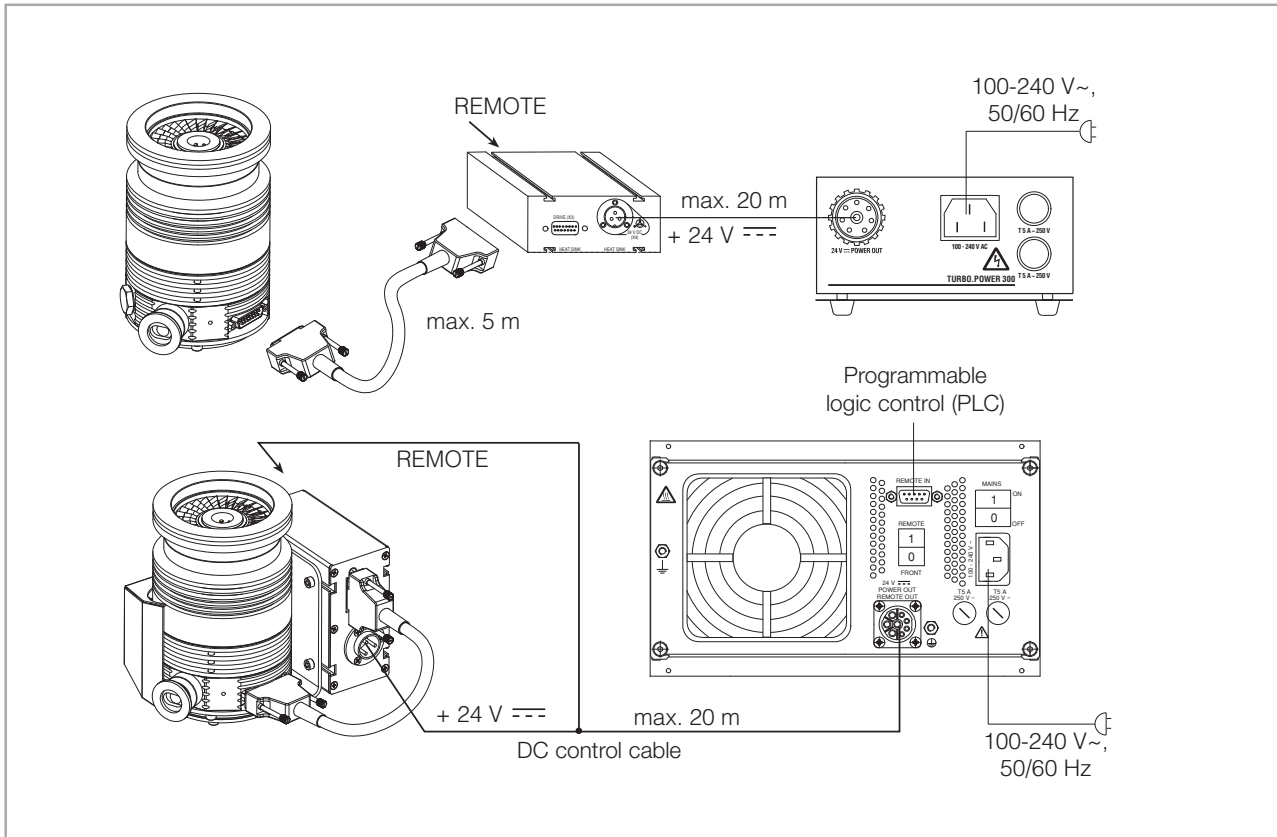

Fig. 3.16 Examples for connection  
 top: TURBOVAC with separate frequency converter to TURBO.POWER 300,  
 bottom: TURBOVAC with integrated frequency converter to TURBO.CONTROL 300

### 3.8.2 Connecting the power supply

The power supply must meet the requirements given in Section 1.5. Peak loads in the kHz range may be present on the DC side. The power supply should have a current limitation or control.

When connecting several frequency converters to a single power supply, then each frequency converter must be fused separately.

#### 24 VDC cable

Connect the frequency converter to the 24 V DC power supply or to the TURBO.CONTROL 300 or to the TURBO.POWER 300 via the 24 V DC cable.

#### NOTICE



Ensure correct polarity.  
 Pin 1 + 24 VDC  
 Pin 2 0 V  
 Pin 3 GND

The frequency converter is equipped with an internal 8 AT (slow blow) fuse. It can only be replaced by Oerlikon Leybold Vacuum staff.

Connect the power supply to the mains.

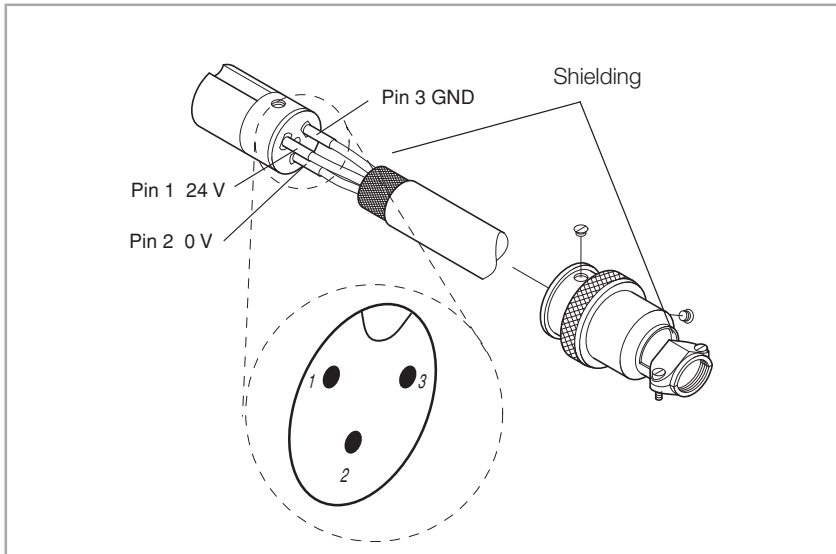

Fig. 3.17 Pin assignment of the DC connector (X4) Model Hirose HS16P-3

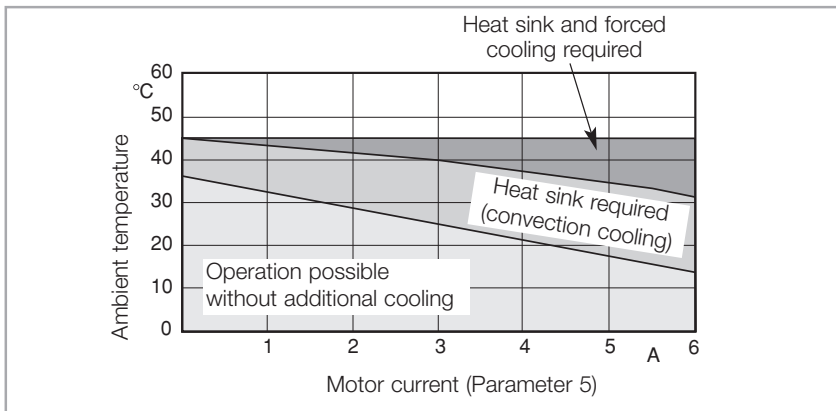

Fig. 3.18 Cooling requirements for the TURBO.DRIVE 400 when fitted separately

**Emergency shut down:** By shutting down the power supply voltage. Please note the information on shutting down and emergency shut down provided in Section "4.5 Shutting down".

### 3.8.3 Mounting the frequency converter

The frequency converter may be affixed with the aid of the enclosed M4 sliding nuts. The bottom side of the frequency converter must be cooled sufficiently.

If the frequency converter is mounted without the optional heat sink ensure sufficient cooling by other means.

# Installation

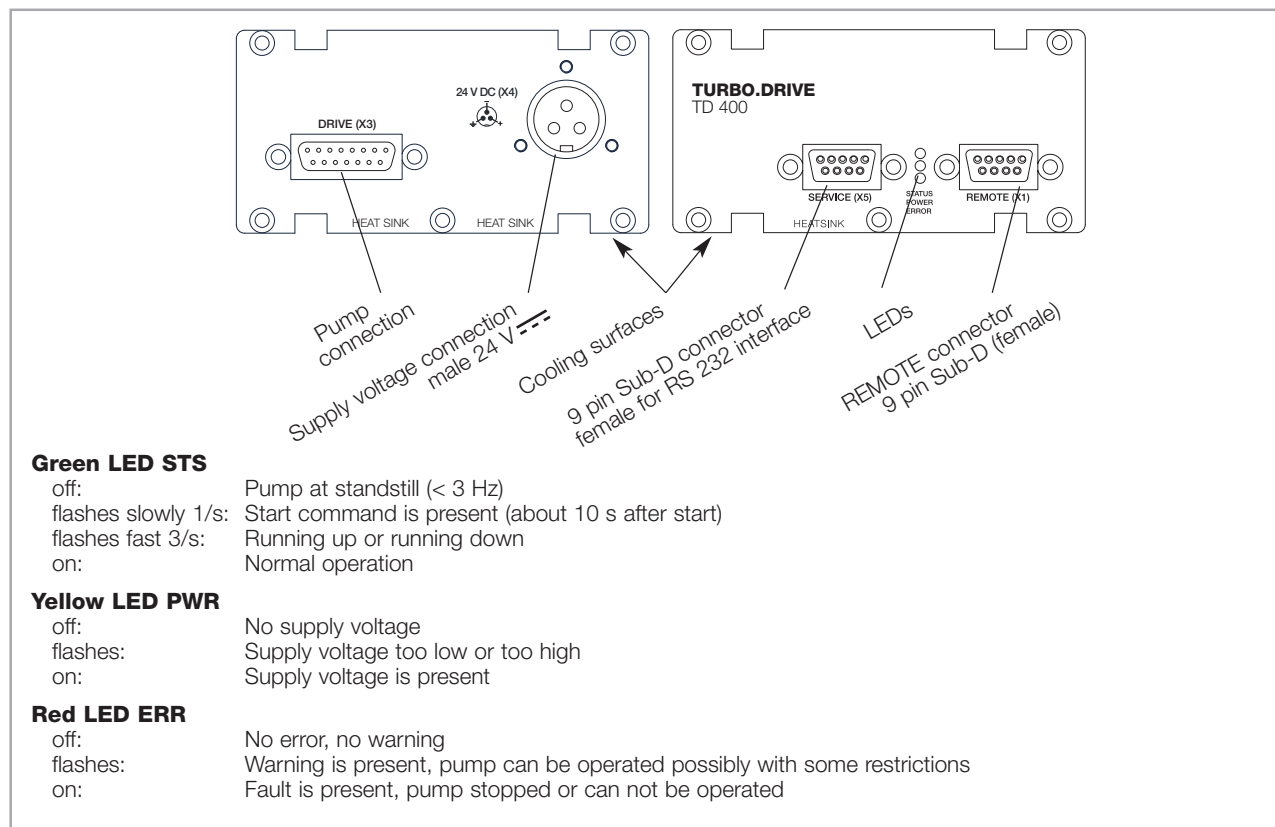

Fig. 3.19 TURBO.DRIVE 400, front and rear side

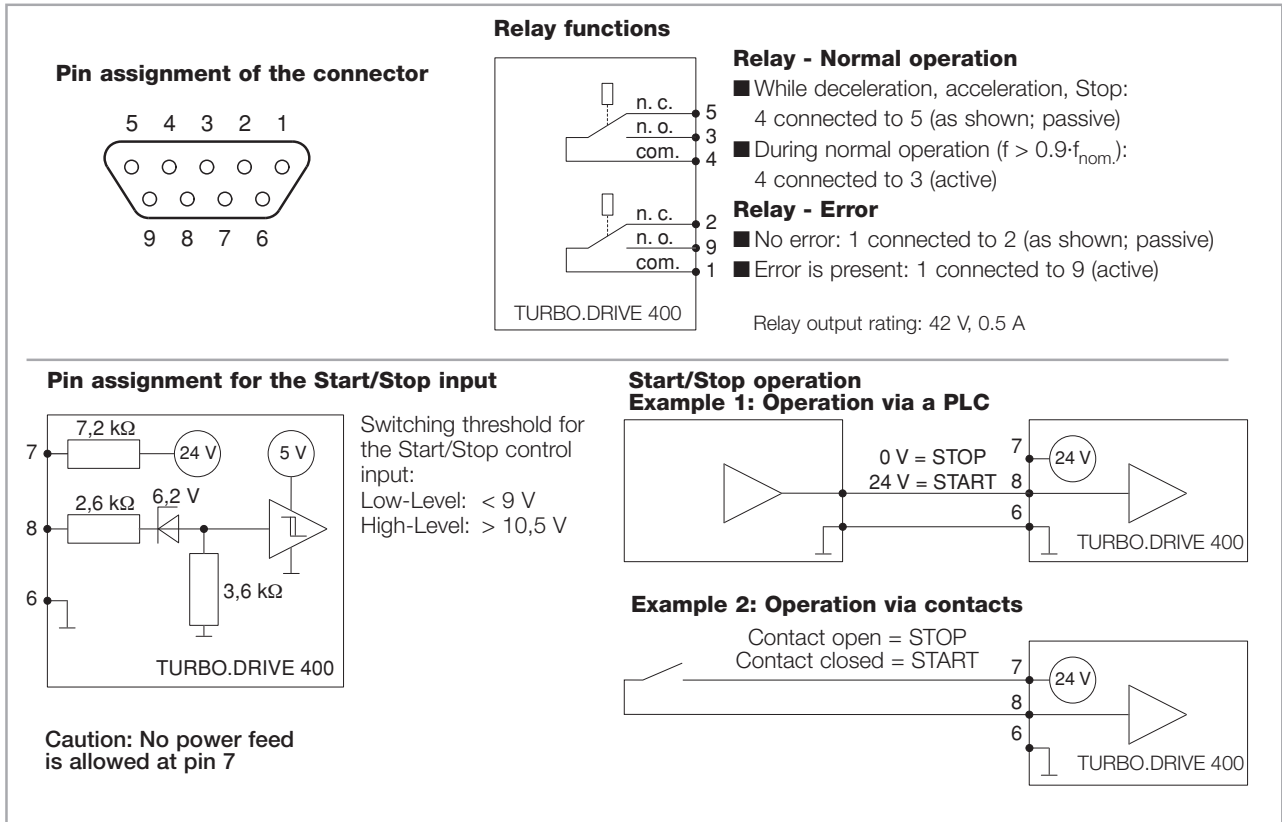

Fig. 3.20 Pin assignment of the REMOTE (X1) connector

# Installation

## 3.8.4 Relay status

Input data / status				Output data				Operating mode	
Start/ stop signal	Pump rotating	Normal frequency ≥ 90% of setpoint frequency	Error is present	Motor drive	Relay NORMAL OPERATION	Relay ERROR	LED STATUS (green)	LED ERROR (red)	Other modes are not possible; they indicate a failure affecting the TURBO.DRIVE 400.
Stop	no	no	no	off	passive	passive	off	off	Pump not operating
Stop	yes	no	no	off	passive	passive	flashes	off	Pump is decelerating
Stop	yes	yes	no	off	passive	passive	flashes	off	Just after stop; pump was in the normal operating mode before that
Start	no	no	no	on	passive	passive	off	off	Just after start
Start	yes	no	no	on	passive	passive	flashes	off	Pump is accelerating
Start	yes	yes	no	on	active	passive	green	off	Pump is in the normal operating mode
Stop	no	no	yes	off	passive	active	off	red	Error is present; pump is at standstill
Stop	yes	no	yes	off	passive	active	flashes	red	Error is present; pump is decelerating
Stop	yes	yes	yes	off	passive	active	flashes	red	Error has just occurred
Start	no	no	yes	off	passive	active	off	red	Error is present; pump is at standstill
Start	yes	no	yes	off	passive	active	flashes	red	Error is present; pump is decelerating
Start	yes	yes	yes	off	passive	active	flashes	red	Error has just occurred

## 4 Operation

### 4.1 Media compatibility / purge gas

The TURBOVAC SL 80 is suitable for pumping air and clean gases.

If reactive gases in low concentrations must be pumped operate the pump with purge gas.

We would be glad to consult with you as regards the media which can safely be handled with this unit.

Install a micropore filter when pumping media which contains dust.

Suited for venting or purging are all gases,

- which will not cause corrosion or pitting in aluminium and steel and
- which in connection with process deposits in the pump will not cause corrosion or sticking.

For venting and as the purge gas we recommend inert gases like nitrogen or argon. The temperature of these gases should be between 5 °C and 80 °C, max. relative humidity should not exceed 10 ppm.

The gas must be clean.

In individual cases and after consultation also dry, filtered, oil-free air or filtered ambient air may be used (filter mesh < 1µm).

Change the filters after some time, at least annually.

### 4.2 Start-up

The TURBO.DRIVE 400 offers the possibility of gently running in pumps which were not operated for a period between 6 and 12 months. Before starting, set up parameter 119 correspondingly.

Turbomolecular pumps which were not operated for a period of over 12 months should be returned to us. For more information on this please contact your local sales partner.

### Suited gases

# Interfaces

## 4.3 Interfaces

The frequency converter has a RS 232 interface as standard (SERVICE X5) and is optionally equipped with serial interfaces:

- RS 485 C
- Profibus DP

The TURBO.DRIVE 400 is configured through the parameters according to the parameter list. Pxxx denotes parameter value xxx.

The PC software "TURBO.DRIVE Server" allows convenient access by the user to the parameters of the frequency converter.

### Interfaces priority level

The optional interface has the highest priority level, followed by the Service interface X5. The Remote input X1 has the lowest priority level. See also parameter 179 in Section 4.3.5.

### Applications which can be implemented with the aid of the serial interface:

Application	Benefits to the customer	How to do it
Networking of several pumps and other equipment	Savings relating to the costs for signalling cables	With Field Bus systems like Profibus
Automation	Savings related to repetitive manual work	For example by a control computer
Avoidance of warnings and warnings before overload operation and early detection of a failing pump	<ul style="list-style-type: none"> <li>■ Precise planning for maintenance</li> <li>■ Improved reliability of sensitive production processes in a vacuum</li> </ul>	Monitoring of: <ul style="list-style-type: none"> <li>■ Motor current P5</li> <li>■ Motor temperature P7</li> <li>■ Frequency converter temperature P11</li> </ul>
Standby operation	<ul style="list-style-type: none"> <li>■ Extending the service life for the ball bearings</li> <li>■ Cutting energy consumption</li> </ul>	Reducing the rotor's frequency through P24
Troubleshooting	Quick analysis of problems	Reading of error memories P171, P174 and P176: error code, speed, operating hours for error
Slow pressure control by changing the pumping speed	Dispensing with a flow controller	Changing the rotor frequency through parameter 24
Reducing the maximum motor current	Cost savings through smaller power supply units if peak loads can be reduced	With P139, motor current reduction factor
Starting the pump with a delay if several consumers are connected to the same PSU	Cost savings through smaller power supply units if peak loads can be reduced	With P36, delay
Frequency converter as a simple pressure gauge, since motor current is dependent on the vacuum conditions	Dispensing with pressure gauges	Monitor motor current P5; second function for "Normal Operation" relay: relay switches as soon as the motor current threshold is tripped. Adjust second function: P29 Set motor current thresh.: P27
Lowering the normal operation threshold	Normal operating mode is attained faster, processes can be started faster	Reduce frequency threshold through P25



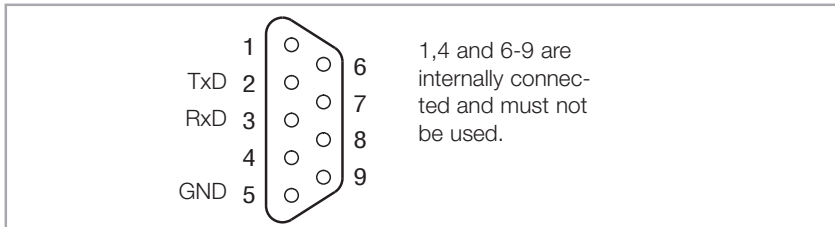

Fig. 4.1 Pin assignment for the socket at the frequency converter (female) SERVICE X5

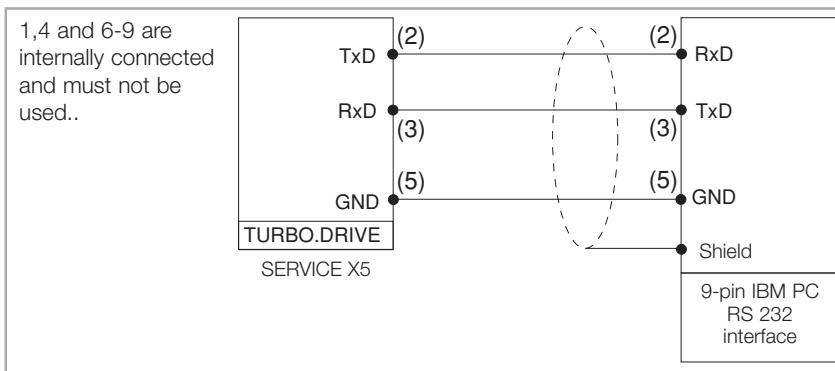

Fig. 4.2 Providing a RS 232 connection

### 4.3.1 RS 232 C interface (SERVICE X5)

Standards	DIN 66020
Protocol	acc. to VDI/VDE 3689
Transmission rate	19200 baud
Response delay	default setting 10 ms (parameter 180)
Address range	non-addressable
Max. cable length	5 m
Interface connector	9 way Sub-D type, socket on the instrument (female) thread UNC4-40

Note: If on the controlling side an RS 232 interface in accordance with the PC standard with a 9-pin Sub-D male connector is present, then a straight through cable as shown in Fig. 4.2 may be used.

Refer also to Operating Instructions GA 05.281

# Interfaces

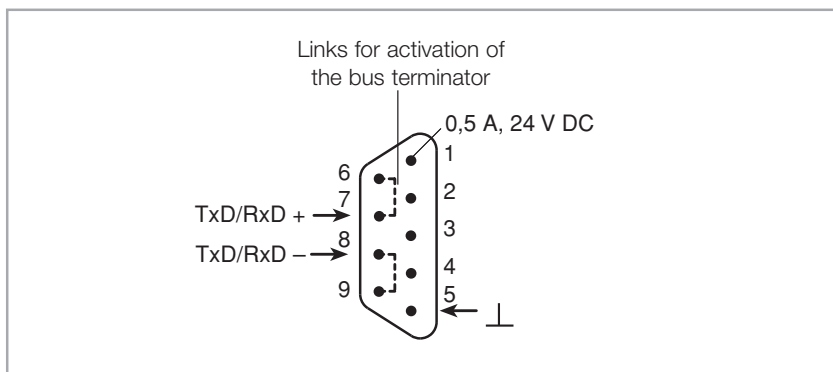

Fig. 4.3 Pin assignment for the socket at the frequency converter for RS 485 interface (male)

## 4.3.2 RS 485 interface

Standards	ISO/IEC 8482, EIA 485
Protocol	acc. to VDI/VDE 3689
Transmission rate	19200 baud fixed
Response delay	default setting 10 ms (parameter 180)
Address range	0 ... 15
Max. cable length	50 m (with bus termination)
Type of cable	2 wire twisted pair (twisted pair cable)
Differential voltage levels (see also "Standards")	logic "0": transmitter: 1.5 ... 5 V receiver: > 0.3 V  logic "1": transmitter: - 1,5 ... - 5 V receiver: ≤ - 0,3 V
Interface connector	9 way Sub-D type, socket on the instrument (male) thread UNC4-40

Note: After having changed the bus address through the rotary switch, the frequency converter must be switched off (yellow power LED off) and then on again so as to enable the new address setting.

Bus addresses over 15 can only be set via Parameter 37.

Refer also to Operating Instructions GA 05.281

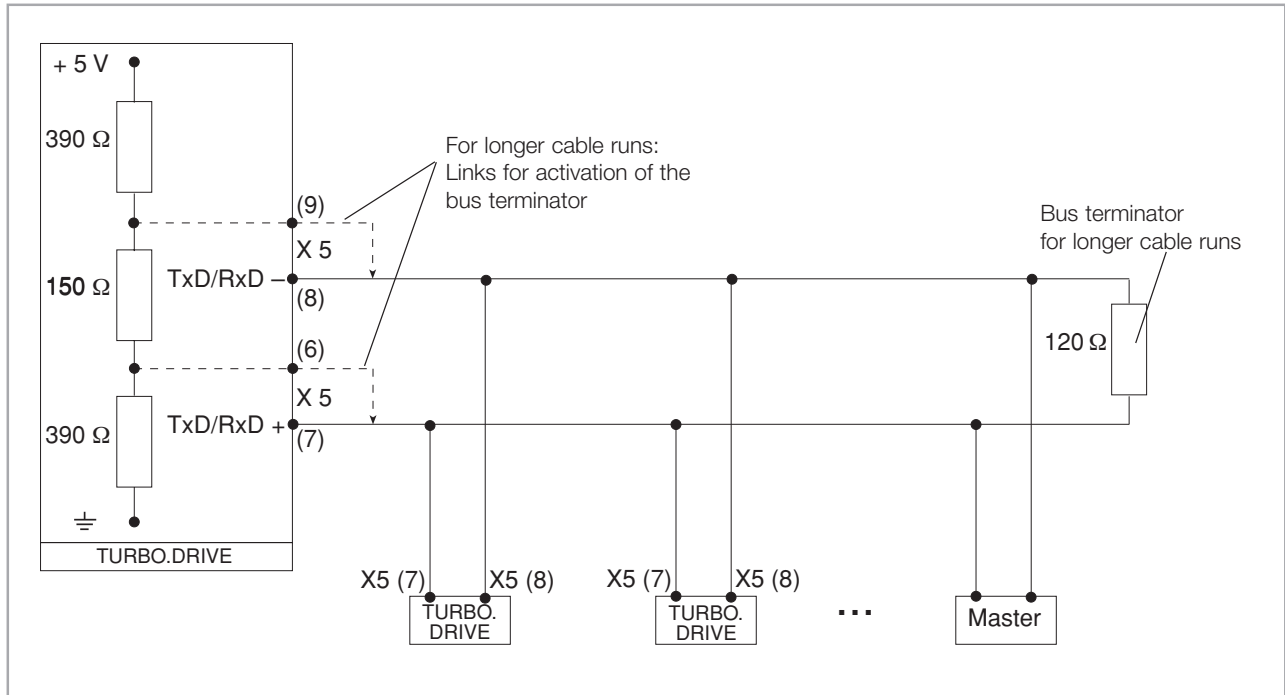

Fig. 4.4 Connection of the RS 485 bus

### 4.3.3 Profibus DP

The Profibus DP used has been defined in the standards EN 50170 and VDI/VDE 3689.

For more information on the Profibus system:

"The New Rapid Way to Profibus DP",  
 Manfred Popp, Profibus Nutzerorganisation e.V.,  
 Haid-und-Neu-Str. 7  
 76131 Karlsruhe, Germany  
 P/N: 4.072  
 www.profibus.com

Upon request we shall be pleased to provide detailed information on the hardware and the protocol used for the data.

Refer also to Operating Instructions GA 05.281

### 4.3.4 Ethernet/IP interface

See additional Operating Instructions 17200908. The Operating Instruction will be delivered on a CD with Part No. 800073V0007 or can be downloaded from our website.

# Interfaces

## 4.3.5 Parameter list

r = readable, w = writable

No.	Designation	Min.	Max.	Default	Unit	r/w	Format	Description
1	Converter type	0	65535	0		r	u16	136 = Turbo.Drive 400
2	Software version	0	65535	10000		r	u32	xx.yy: version, zz: correction index
3	Actual frequency	0	65535	0	Hz	r	u16	Actual rotor frequency
4	Actual intermediate circuit voltage	0	1500	30	0,1 V	r	u16	Actual intermediate circuit voltage of the converter
5	Actual current	0	150	0	0,1 A	r	u16	Actual motor current
6	Actual electrical power	0	65535	0	0,1 W	r	u16	Actual drive input power
7	Actual motor temperature	-10	150	0	°C	r	i16	Actual value of the motor temperature.
8	Save data command	0	65535	0		/w	i16	A write command with any value saves temporary data into nonvolatile memory.
11	Actual converter temperature	-10	150	0	°C	r	i16	Actual heat sink temperature of the converter.
16	Motor temperature warning threshold	0	150	85	°C	r	i16	Exceeding the motor temperature warning threshold results in a warning.
17	Nominal motor current	5	60	5,0	0,1 A	r	u16	Maximum permissible motor current
18	Maximum frequency	750	1200	1200	Hz	r	u16	Highest permissible frequency
19	Minimum frequency	0	1200	910	Hz	r	u16	Lowest permissible frequency
20	Critical frequency	0	1200	600	Hz	r	u16	Minimum frequency level. When the pump is accelerating this frequency must be reached within the maximum passing time (P183).
23	Pump type	0	255	5		r	u16	5= SL 80
24	Setpoint frequency	0	1200	1200	Hz	r/w	u16	Setpoint of the rotor frequency
25	Normal operation	35	99	95	%	r/w	u16	Setpoint of the frequency dependent normal operation level
27	Current norm. oper.	5	60	20	0,1 A	r/w	u16	Motor current dependent normal operation level; ; If P29[0] = 1: Defines the normal operation level. Normal operation if P5 <= P27 Parameter cannot be changed during operation of the system
29	Relay function X1	0	8	0		r/w	u16	If required, special functions can be assigned to the normal operation and the error relay.

Field 0 specifies the function for normal operation:

- 0 = Frequency dependent
- 1 = Motor current dependent
- 2 = Fieldbus controlled
- 3 = Trigger current bearing temperature (P122)
- 4 = Venting function (P247/P248)
- 5 = Pump at standstill (f < 3)
- 6 = Start command is present
- 7 = Ready for switch on (=STW Bit1)
- 8 = No mains power failure or no generator operation (P303 Bit 4 =1 = generator operation)

Field 1 specifies the function for the error relay:

- 0 = Energised when an error is present
- 1 = Deenergised when an error is present
- 2 = Fieldbus controlled

No.	Designation	Min.	Max.	Default	Unit	r/w	Format	Description
32	Max. run-up time	30	2000	720	s	r/w	u16	Max. permissible time during which the pump must attain the normal operation threshold (P24*P25) with the start signal present.
36	Start delay time	0	255	0	0,1 min	r/w	u16	Delays the start of the pump to allow lead-time for the fore vacuum pump for example.
37	RS485 address	0	31	0		r/w	u16	Parameterizable RS485 address; The address is specified either through the address switch or a value entered here provided the address switch is set to 0. A change of this parameter setting will only be effective after the power supply has been switched off and on.
119	Bearing run-in function	0	1	0		r/w	u16	0=deactivated 1=new pump type starts with run-in sequence
	Run in using the run-in sequence specified through the pump table without run-up time monitoring							
	Run-in speed 1 [Hz]	Run-in time 1 [s]	Run-in speed 2 [Hz]	Run-in time 2 [s]	Run-in speed 3 [Hz]	Run-in time 3 [s]		
	180	3600	350	5400	600	5400		
122	Normal TMS	20	70	40	°C	r/w	u16	Switch-on temperature for fan when P29[0]=3. For P125 > P122 the normal operation relay is energised.
125	Motor temperature	-10	150	0	°C	r	i16	like P7
126	Bearing temperature warning threshold	-10	150	60	°C	r	i16	not used for SL 80
127	Motor temperature	-10	150	0	°C	r	i16	like P7
128	Motor temperature lower warning threshold	-10	150	2	°C	r	i16	Falling below the motor temperature lower warning threshold results in a warning.
131	Motor temperature lower error threshold	10	150	-10	°C	r	i16	Falling below the motor temperature lower error threshold causes the pump to be switched off.
132	Bearing temperature error threshold	-10	150	67	°C	r	i16	not used for SL 80
133	Motor temperature error threshold	-10	150	90	°C	r	i16	Exceeding the motor temperature error threshold causes the pump to be switched off.
134	Enable cooling fan on turbopump	0	19	19		r/w	116	0 = Cooling fan off 19 = Cooling fan on
139	Current reduction factor e.g. for adaptation of low performance power supplies. Note: values < 100 reduce the pump performance and increase the run-up time.	30	100	100	%	r/w	u16	
140	Intermediate circuit current	0	150	0	0,1 A	r	i16	Actual average intermediate circuit current of the converter.
150	Standby frequency	0	1200	910	Hz	r/w	u16	Standby operation frequency setpoint
151	Enable standby	0	1	0		r/w	u16	0 = normal speed (P24); 1 = standby speed (P150)

# Interfaces

No.	Designation	Min.	Max.	Default	Unit	r/w	Format	Description
171	Error code memory	0	65535	0		r	u16	Indexed parameter for storing the most recent 40 error codes. The individual error memory entries are accessed via this parameter with additional index number. The last error code is accessed with index 0 and the oldest with index 39. See Section 5 Troubleshooting for the error codes.
174	Error rotor frequency	0	65535	0	Hz	r	u16	Actual speed, when error occurred. Access analogously as for parameter 171.
176	Error operating hours	0	2147483647	0	h	r	u32	Operating hours, when error occurred. Access analogously as for parameter 171.
179	Fallback PZD1	0	65535	1024		r/w	u16	Response when cancelling the control rights or in the case of a communication interruption of the bus adapter Behaviour in case bit 10 in the control word of the bus adapter is cancelled or when interrupting the communication between converter and bus adapter (see also P182). Here it is assumed that the respective bus adapters perform a cyclic communication on the USS side, so that the respective converter electronics is capable of detecting a communication interruption The bits in parameter 179 represent an equivalent to the control word in the USS protocol. The actions linked to these bits are run provided bit 10 in the control word (USS protocol for bus adapter) is cancelled or if there are interruptions in the communication between converter and bus adapter. Here bit 10 is of special significance: Bit 10 = 0 The control rights are returned to the next lower priority level. All other bits are not relevant. Bit 10 = 1 The control rights remain unchanged. The actions linked to the other bits are run.
180	Resp. delay time	0	20	10	ms	r/w	u16	Response delay time; Pause time between received and transmitted USS protocol string of the frequency converter's serial interface RS232 and RS485. We recommend not to change the default setting (10ms).
182	Watchdog timer USS	0	65535	10	0,1 s	r/w	u16	Delay when cancelling the control rights of the bus adapter and time-out in the case of a communication interruption Defines the time characteristic when cancelling bit 10 in the control word of the USS protocol or when an interruption in the communication between bus adapter and converter and electronics is detected. Handling when cancelling bit 10 or when there is an interruption on the communication side of the USS bus adapter, is the same. Value 0.0: Indefinite time delay. In this way a change of the control right is inhibited. Values 0.1 ..6553.5: A change in the control right corresponding to the setting of parameter 179 is only effected after the time span defined through parameter 182 has elapsed.
183	Max. passing time	0	1800	500	s	r	u16	Max. permissible time during which the pump must - with the start signal present - have passed through the critical speed range between 60 Hz and P20.
184	Converter operating hours	0	2147483647	0	0,01 h	r	u32	Counts the operating hours of the converter during active pump operation.
227	Warning bits 1	0	65535	0		r	u16	Active warnings described bit per bit. See Section 3.3.6.
247	Vent on frequency	0	1200	300	Hz	r/w	u16	Frequency at which the venting valve shall be switched on in the event of a mains power failure. Power failure venting can be enabled through P240.
248	Vent off frequency	0	1200	5	Hz	r/w	u16	Frequency at which the venting valve shall be switched off in the event of a mains power failure. Power failure venting can be enabled through P240.
249	Generator operation	0	1	0		r/w	u16	0 = inactive 1 = active

No.	Designation	Min.	Max.	Default	Unit	r/w	Format	Description
303	Actual operating status	0	65535	0		r	u16	Bit 0: Normal operation Bit 1: Ready for switch on Bit 2: Speed is increasing Bit 3: Speed is dropping Bit 4: Generator operation Bit 5: Standby Bit 6: reserved Bit 7: reserved
312	Catalog number of converter	0	127		:CHAR [8000xxV000x]	r	u16	Catalogue number of the converter. One ASCII char per index.
313	Product name (Index 0...10 usable)	0	127	[TD_400]	:CHAR :CHAR	r	u16	Product name of the converter. One ASCII char per index. Only for DeviceNet purpose
315	Serial number of converter (Index 0...10 usable)	0	127		:CHAR [xxxxxxxxxx]	r	u16	Serial number of the converter. One ASCII char per index.
918	Act. Profibus addr.	0	65535	0		r	u16	Active Profibus address
947	Current error number	0	65535	0		r	u16	Currently pending error. See Section 5 Troubleshooting.

# Interfaces

## 4.3.6 Warning codes for parameter 227

P227, Bit	Designation	Meaning	Possible cause	Remedy
0	Motor temperature warning	The motor temperature has passed the warning threshold	Forevacuum pressure too high. Gas flow too high Fan defective Water cooling switched off	Check the ultimate pressure of the backing pump and install a bigger backing pump if req. Seal leak, check process Replace fan Switch on water cooling
1	Converter temperature warning	Overtemperature at the power output stage or within the frequency converter	Ambient temperature too high Poor cooling	Ensure max. ambient temperature of 45°C Improve cooling
2	not used			
3	Motor under-temperature warning	The minimum permissible motor temperature (warning threshold) is not reached.	Ambient temperature too low Pump cooling too high	Ensure min. ambient temperature of 0°C Reduce water cooling
4, 5	not used			
6	Overspeed warning			
7, 8, 9, 10	not used			
11	Overload warning	The pump speed has dropped under the normal operation threshold	Forevacuum pressure too high. Gas flow too high	Check the ultimate pressure of the backing pump and install a bigger backing pump if req. Seal leak, check process
12, 13	not used			
14	Power supply voltage warning	Supply voltage failure during active operation of the pump $P4 > U_{max}$ or $P4 < U_{min}$	Intermediate circuit voltage too low or maximum time for generator operation was exceeded. DC power supply voltage below 24V Mains voltage failure	
15	Fan voltage has failed			



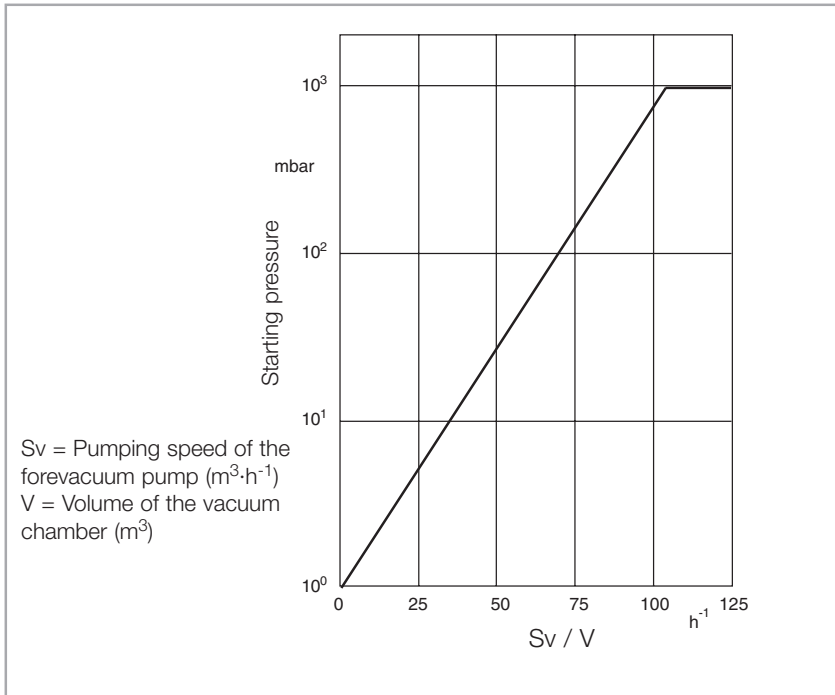

Fig. 4.5 Determining the starting pressure of a turbomolecular pump when evacuating large volumes

#### 4.4 Switching on

Switch on the 24 V DC power supply. The yellow LED at the frequency converter lights up.

The maximum starting pressure for the turbomolecular pump can be read from the graph in Fig. 4.5.

Switch on the turbomolecular pump at the frequency converter

- via pins 7 and 8 of the socket REMOTE (X1) (see Fig. 3.18) (For example via a remote control or with the aid of the plug with integrated ON/OFF switch: see Section 1.5 Accessories).
- by a start command via the interface; see Section 4.3.
- For the power supply units offered or recommended by Oerlikon Leybold Vacuum: If the contacts 7 and 8 at the REMOTE (X1) connector are closed the pump starts automatically when the DC voltage is switched on (provided parameter 12 is set to 0).

The turbomolecular pump accelerates. The green LED flashes. When the pump reaches normal operation the green LED lights up permanently.

Avoid the influences of shock and vibration when the pump is running.

Exposure of the pump to accelerating forces must be avoided or reduced to such an extent that the rotor unit will not be excited by vibrations. In the case of critical applications you must consult our Applications Dept. first.

#### Starting pressure

#### NOTICE



# Operation

After a mains power failure the pump can run up automatically once more.

## 4.5 Shutting down

Switch off the pump at the frequency converter.

- via contacts 7 and 8 of the socket REMOTE (X1), if parameter 12 = 0.
- apply a stop command via the interface, if parameter 12 = 1 or 2.
- for the power supply units offered or recommended by Oerlikon Leybold Vacuum switch off the DC voltage.

### Generator operation

After switching off, the green status LED will flash until the rotor of the turbomolecular pump is at standstill. This may take several minutes. With the DC power supply off, the turbomolecular pump will act as a generator supplying the frequency converter with energy as indicated by the yellow power LED.

Switch off the forevacuum pump.

### Venting

When using oil-sealed forevacuum pumps, vent the turbomolecular pump before it comes to a stop; refer to Section 4.6.

When using TRIVAC pumps the built-in anti-suckback valve will close automatically, shutting off the forevacuum line. In forevacuum pumps without a vacuum retention valve, close the valve in the forevacuum line.

When the system is not operating, ensure that neither ambient air nor cleaning media can enter the pump.

If a failure occurs the turbomolecular pump will be shut down automatically. The red LED at the frequency converter lights up.

### Emergency shut down

In the case of an emergency shut down, the pump is switched off as described above. The rotor of the turbomolecular pump may be stopped faster by venting the pump.

Under vacuum conditions the pump may take up to one hour to run down, when venting to atmospheric pressure it may take up to one minute. During the time the pump is running down, the green LED at the frequency converter will flash, indicating that the rotor has not yet arrived at standstill.

When shutting down by **switching off the power supply voltage**, there will be only enough power for the LEDs down to a speed of the pump of approximately 200 Hz. Thus the pump may still turn without a LED being on. For this reason, when switching off without venting, wait for approximately 15 minutes after the LEDs have turned off until the pump has arrived at standstill.

---

### CAUTION



Unplug any connectors only when the mains voltage is switched off **and** the pump does no longer turn (the green LED is off).

## 4.6 Venting

Refer to Section 4.1 for suited gases.

### Venting Methods

There are three different methods of venting the turbomolecular pump.

In the case processes requiring a purge gas, the pump must be vented via the **purge gas and venting valve** when shutting the pump down.

When additionally venting the vacuum chamber, the venting function of the purge gas and venting valve must be opened before opening the chamber valve. This will ensure the presence of a higher pressure in the area of the ball bearings compared to the remaining vacuum area. This will prevent particles, dust or aggressive gases from being forced through the bearings into the not yet vented motor chamber of the pump.

Cautious venting of the pump is possible from the **high vacuum side**, since here the bearing forces will be lowest. When doing so, no free jet of gas must be allowed to form on the rotor so as to avoid exposing the rotor to additional forces.

When venting the pump through its **foreline connection**, neither oil nor particles may be entrained in the gas flow from the forevacuum side into the pump.

### Speed of the Pressure Rise

All turbomolecular pumps may be vented at full speed. However, the pressure must not increase faster than specified through the pressure rise curve.

The pump must be vented significantly slower when there is the risk of particles entering into the pump from the process. During venting, the flow must be of the laminar type in both the vacuum chamber and the turbomolecular pump.

The speed of the pressure rise during venting of the running pump will greatly influence the load on the rotor/stator pack and the bearings. The slower the pump is vented, the longer the service life of the bearings will be.

The pump must not be vented to pressures above atmospheric pressure.

**Speed  
Pressure rise curve**

**Particles**

# Operation

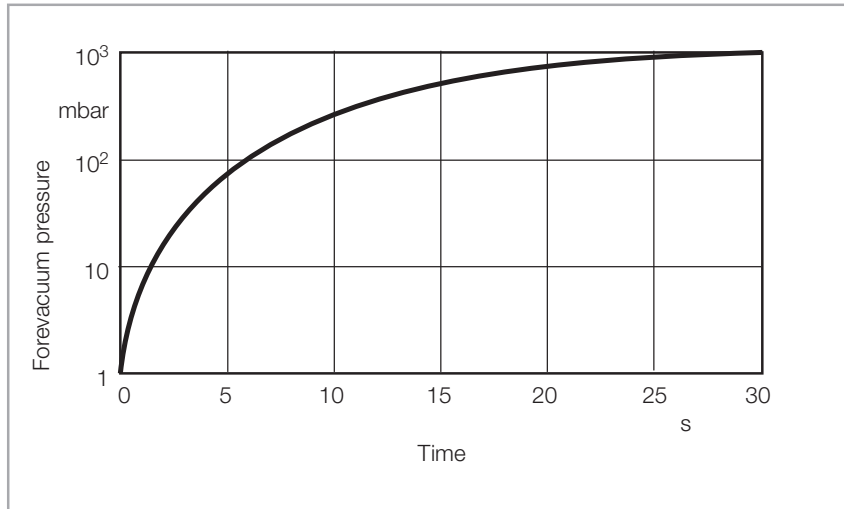

Fig. 4.6 Maximum rise in pressure

## 4.7 Bakeout

For TURBOVACs with CF flange

If pressures in the range of  $10^{-8}$  mbar or below are to be developed, the vacuum chamber and the components installed therein will have to be baked out. In addition, the TURBOVAC can be baked out using the flange heater provided for this purpose.

Protect the rotor against intensive, direct heat radiation. When baking out at the forevacuum side – at a sorption trap, for example – ensure that the components attached direct are not heated to more than 100 °C (212 °F).

The forevacuum pump must be in operation so as to eliminate the vapors liberated at the sorption trap.

## 4.8 Removing the pump from the system

Shut down the pump and vent as described in Sections 4.5 and 4.6.

If the pump has previously handled hazardous gases, implement the proper precautionary measures before opening the intake or exhaust connection.

Observe Safety Informations 0.4.6.

Disconnect the pump only when it has come to a full stop. The green LED at the frequency converter must have gone out.

Then switch the mains power off and wait until the yellow power LED is off. Then only disconnect any cable connections.

The pumps may be contaminated with process gases. These gases may be toxic and hazardous to health. In addition, deposits with similarly dangerous properties may have formed. Many of these gases and deposits form acids when they come into contact with humid air. This will result in serious corrosion damage to the pump.

To avoid health hazards and corrosion damage when the pumps are detached from the system, fasten a container of desiccant under the transport cover of the high-vacuum connection and then close the pump immediately at all flange connections. Store the pump, with a desiccant, in an airtight PE bag.

Corrosion damage due to faulty packing will nullify the guarantee.

Pack the pump so that it cannot be damaged during shipping and storage. Pay particular attention to protection for the flanges and the electrical plug.

Observe the instructions in Section 5.2 if you forward the pump to Oerlikon Leybold Vacuum.

---

### DANGER



### Hazardous gases

### Deposits

### Desiccant

# Maintenance

## 5 Maintenance

### Rotor exchange

We recommend an exchange of the rotor unit after 80,000 operating hours at the latest.

Such maintenance work can only be done by the Oerlikon Leybold Vacuum Service. If required contact the Oerlikon Leybold Vacuum service center nearest to your location. You can find the address on our internet page [www.oerlikon.com](http://www.oerlikon.com).

At high pump loads - for example during cyclic operation, at high gas throughputs or at high ambient temperatures - the aforementioned maintenance work should be carried forward. Please consult Oerlikon Leybold Vacuum for recommendations.

---

### WARNING



Observe Safety information 0.1.7.

---

### Purge gas filter

Depending on the degree of contamination of the purge gas used the filter will clog and will have to be exchanged (our experience indicates that this will become necessary after 1 to 6 months).

### Adsorption trap

When an adsorption trap is used, regenerate or renew the adsorption agent regularly; refer to the operating instructions provided with the trap.

### 5.1 Cleaning

If required clean the turbomolecular pump of dust with a dry cloth.

#### Cleaning the frequency converter internally

The converter essentially requires no servicing since it contains no components which could be adjusted.

Depending on the installation particulars and the ambient conditions, the converter may collect grime (dust, moisture) on the inside. Such contamination can lead to malfunctions, overheating or short circuits and will have to be avoided to the maximum extent possible. The Oerlikon Leybold Vacuum Service Department can clean the converter. We recommend adhering to a cleaning interval of about five years.

## 5.2 Oerlikon Leybold Vacuum Service

Whenever you send us in equipment, indicate whether the equipment is contaminated or is free of substances which could pose a health hazard. If it is contaminated, specify exactly which substances are involved. You must use the form we have prepared for this purpose.

A copy of the form has been reproduced at the end of these Operating Instructions: "Declaration of Contamination for Compressors, Vacuum Pumps and Components". Another suitable form is available from [www.oerlikon.com](http://www.oerlikon.com) → Oerlikon Leybold Vacuum → Documentation → Download Documents.

Attach the form to the equipment or enclose it with the equipment.

This statement detailing the type of contamination is required to satisfy legal requirements and for the protection of our employees.

We must return to the sender any equipment which is not accompanied by a contamination statement.

### Contamination

### Form

# Troubleshooting

## 6 Troubleshooting

---

**CAUTION**

When the connector cable is attached, the outputs at the frequency converter are not free of voltage.

Before you start searching for the source of the problem, you should carry out a few simple checks:

Are the connections in good working order?

- Mains connection,
- 24 V DC cable to the frequency converter,
- Connector cable between the frequency converter and the pump

Is the forevacuum pressure sufficient?

After having removed the cause for the error reset the error message at the TURBO.DRIVE:

- In case of errors with error codes 1 to 7 by applying a STOP signal via the socket REMOTE (X1) or the serial interface or by switching the mains power off.
- In case of error code 8 by switching the mains power off.

The error codes can only be read if a serial interface is present.

The following table has been provided as a guide when determining the causes of errors.



# Troubleshooting

Error code	Designation	Meaning	Possible Cause	Remedy	Shut-down
1	Overspeed warning	The actual frequency exceeds the setpoint by over 10 Hz.	Frequency converter defective	Contact Oerlikon Leybold Vacuum Service.	no
2	Pass through time error	The pump has not reached the minimum speed after the maximum run-up time has elapsed.	Forevacuum pressure too high. Gas flow too high Rotor blocked	Check the ultimate pressure of the backing pump and install a bigger backing pump if req. Seal leak, check process Check if the rotor turns freely. Contact Oerlikon Leybold Vacuum Service if the rotor is damaged or blocked.	yes
3	not used				
4	Short circuit error				yes
5	Converter temperature error	Overtemperature at the power output stage or within the frequency converter	Ambient temperature too high Poor cooling	Ensure max. ambient temperature of 45°C Improve cooling	yes
6	Run-up time error	The pump has not reached the normal operating frequency after the maximum run-up time.	Forevacuum pressure too high. Gas flow too high	Check the ultimate pressure of the backing pump and install a bigger backing pump if req. Seal leak, check process	yes
7	Motor temperature error	The motor temperature has exceeded the shutdown threshold.	Forevacuum pressure too high. Gas flow too high Fan defective Water cooling switched off	Check the ultimate pressure of the backing pump and install a bigger backing pump if req. Seal leak, check process Replace fan Switch on water cooling	yes
8	Pump error	Pump couldn't be identified or no pump is connected	Pump not connected correctly to frequency converter Frequency converter software not current, Hardware defective	Check connection between pump and frequency converter Contact Oerlikon Leybold Vacuum Service Contact Oerlikon Leybold Vacuum Service	yes

# Troubleshooting

Error code	Designation	Meaning	Possible Cause	Remedy	Shut-down
82	Fan voltage has failed				no
83	Motor temperature low warning				no
84	Motor overtemperature warning				no
101	overload warning	The pump speed has dropped under the normal operation threshold	Forevacuum pressure too high. Gas flow too high	Check the ultimate pressure of the backing pump and install a bigger backing pump if req. Seal leak, check process	no
103	Supply voltage warning	Intermediate circuit voltage too low or maximum time for generator operation was exceeded.	DC supply voltage below 24V Mains voltage has failed	Check the voltage at the power supply and if required set up correctly Remedy the cause for the mains power failure	no
106	overload error	The pump speed has dropped under the minimum speed	Forevacuum pressure too high. Gas flow too high	Check the ultimate pressure of the backing pump and install a bigger backing pump if req. Seal leak, check process	yes
111	Motor undertemperature error	The minimum permissible motor temperature is not attained.	Ambient temperature too low Pump cooling too high	Ensure min. ambient temperature of 0°C Reduce water cooling	yes
116	Permanent overload error	The speed of the pump has dropped below the normal operation threshold and has stayed there for a longer period of time.	Forevacuum pressure too high. Gas flow too high	Check the ultimate pressure of the backing pump and install a bigger backing pump if req. Seal leak, check process	yes
117	Motor current error	Motor current less than nominal current	Cable fault Faulty connector	Contact Oerlikon Leybold Vacuum Service	yes
128	Motor temperature sensor error	Motor temperature sensor defective	Sensor defective, short circuit or broken cable	Contact Oerlikon Leybold Vacuum Service	yes
143	Overspeed error				yes

# Troubleshooting

Error code	Error	Possible Cause	Remedy	Shut-down
-	Yellow power LED is not on	No DC power DC power miswired Frequency converter defective	Check cables and power supply Ensure correct polarity of the DC cable. Replace frequency converter. The following may damage the freq. converter: ■ Disconnection of the DC cable while the pump was still rotating ■ Non-compliance with the note related to connecting several pump to a single power supply.	-
div.	Red LED flashes	Warning message. See Section "3.3.6 Warning codes" for the possible reasons of the warning.	The pump can continue to run, as long as operation limits are only exceeded for a short time. In case of longer exceeding send pump and frequency converter to the OLV service.	no
-	Turbomolecular pump does not start, ERROR LED does not light.	Interface protocol error No communication via the serial interface. REMOTE connector (X1) connected wrongly. REMOTE and SERVICE connectors mixed up. Wrong Profibus address set.	Use USS protocol. Connect bus as shown in Section 3.3. Connect as shown in Fig. 3.20 Connect correctly. Set address between 0 and 126.	-
-	Turbomolecular pump produces loud running noises and vibrations.	Rotor out of balance Bearing defective	Balance the rotor Replace the bearing	no
-	Turbomolecular pump does not reach ultimate pressure.	Measurement instrument defective Measurement sensors soiled Leaks at the equipment, lines or the pump Pump soiled Forevacuum pump provides insufficient pumping speed or ultimate pressure which is too high. Frequency parameters programmed wrongly	Inspect the measurement sensor Clean or replace the sensors Check for leaks Clean the pump Check the ultimate pressure of the forevacuum pump and install a higher-capacity vacuum pump if necessary Check parameters.	no
-	Running pump can not be stopped via X1	Pump has been started via the serial interface, the interface controls the pump	Disconnect the DC supply or connect serial interface and stop via bus	no

# Disposal

## Contamination

### 7 Waste disposal

The equipment may have been contaminated by the process or by environmental influences. In this case the equipment must be decontaminated in accordance with the relevant regulations. We offer this service at fixed prices. Further details are available on request.

---

#### WARNING



Contaminated parts can be detrimental to health and environment. Before beginning with any work, first find out whether any parts are contaminated. Adhere to the relevant regulations and take the necessary precautions when handling contaminated parts.

Separate clean components according to their materials, and dispose of these accordingly. We offer this service. Further details are available on request.

When sending us any equipment, observe the regulations given in Section "5.2 Oerlikon Leybold Vacuum service".

Our products comply with the requirements of the EC Machinery Directive (up to December 28, 2009: 98/37/EG, from December 29, 2009: 2006/42/EG ) and fulfil the corresponding regulations laid down in the Low Voltage Directive (LVD) (2006/95/EG) und Electromagnetic Compatibility (EMC) Directive (2004/108/EG).

An Incorporation Declaration in accordance with the EC Machinery Directive (2006/42/EG) is provided on the next page.

Should you require a separate copy of the Incorporation Declaration with the current date, then please request it from [documentation.vacuum@oerlikon.com](mailto:documentation.vacuum@oerlikon.com).

In order to be able to send you the proper Incorporation Declaration, we require the part number and the serial number of the corresponding product as well as your full address.

You can contact our technical documentation officer – Mr. Herbert Etges – best through the following e-mail address [documentation.vacuum@oerlikon.com](mailto:documentation.vacuum@oerlikon.com) .

**Oerlikon Leybold Vacuum GmbH**

Bonner Straße 498

D-50968 Köln

Tel.: +49-(0)221-347 1234

Fax: +49-(0)221-347 1245

[documentation.vacuum@oerlikon.com](mailto:documentation.vacuum@oerlikon.com)

## EC Incorporation Declaration

The manufacturer: Oerlikon Leybold Vacuum GmbH  
Bonner Straße 498  
D-50968 Cologne  
Germany  
Tel.: +49(0)221 347-0  
email@oerlikon.com

herewith declares that the following product:

Product designation: **Turbomolecular pump**

Type designation:	P/N		
TURBOVAC SL 80	800002V3xxx		
TURBOVAC TW 70 H	800002V1xxx	800002V2xxx	800003V1934
	800002V4937		
TURBOVAC TW 70 LS	800005V0954		
TURBOVAC TW 70 LS2	800159V0001		

x=1 to 9

complies with the following fundamental requirements of the **EC Machinery Directive (2006/42/EG)**:  
Annex I, Paragraph 1.1.2, 1.1.3, 1.1.5, 1.2.1, 1.2.3, 1.2.4.1, 1.2.4.2, 1.2.6, 1.3.1, 1.3.2, 1.3.3, 1.3.4,  
1.3.7, 1.5.1, 1.5.2, 1.5.4, 1.5.5, 1.5.13, 1.6.1 and 1.7.1

Moreover, the incomplete machine complies with all regulations laid down in the **Low Voltage Directive (LVD) (2006/95/EG)**.

The following harmonised standards have been applied:

EN 1012-2,	1996	Compressors and vacuum pumps - Safety requirements - Part 2: Vacuum pumps
EN 61010-1	2001	Safety requirements for electrical equipment for measurement, control, and laboratory use - Part 1: General requirements

The incomplete machine may only be put into operation after it has been determined that the machine into which the incomplete machine shall be installed complies with the regulations laid down in the EC Machinery Directive (2006/42/EG).

The manufacturer commits himself to make the special documentation on the incomplete machine electronically available to national authorities upon request.

The special engineering documentation belonging to the machine was compiled in accordance with Annex VII Part B.

Documentation Officer

Herbert Etges  
Tel.: +49(0)221 347-0  
Fax: + 49(0)221 347 1250  
Documentation.vacuum@oerlikon.com  
Oerlikon Leybold Vacuum GmbH  
Bonner Straße 498 , D-50968 Cologne  
Germany

Cologne, dated *23.09.09*

  
Dr. Monika Mattern-Klosson  
Head of Research & Development

Cologne, dated *23.09.09*

  
Harald Udelhoven  
Head of Quality Management

300296213\_002\_A0 - 09/2009



## EC Declaration of Conformity

The manufacturer: Oerlikon Leybold Vacuum GmbH  
Bonner Straße 498  
D-50968 Cologne  
Germany  
Tel.: +49(0)221 347-0  
[email@oerlikon.com](mailto:email@oerlikon.com)

herewith declares that the products specified and listed below which we have placed on the market, comply with the applicable EC Council Directives.

This declaration becomes invalid if modifications are made to the product without agreement of Oerlikon Leybold Vacuum GmbH.

Compliance with the EMC Directives requires that the components are installed within a system or machine in a manner adapted to EMC requirements.

Product designation: **Turbomolecular pump**

Type designation:	P/N		
TURBOVAC SL 80	800002V3xxx		
TURBOVAC TW 70 H	800002V1xxx	800002V2xxx	800003V1934
	800002V4937		
		x=1 to 9	

**The product complies to the following European Council Directives:**

EC-Directive relating to **electromagnetic compatibility (2004/108/EG)**.

The following harmonised standard has been applied:

EN 61326-1, 2006 Electrical equipment for measurement, control and laboratory use  
— EMC requirements — Part 1: General requirements

Cologne, dated *23.09.09*

Dr. Monika Mattern-Klosson  
Head of Research & Development

Cologne, dated *23.9.09*

Harald Udelhoven  
Head of Quality Management

**Declaration of Contamination of Compressors, Vacuum Pumps and Components**

The repair and / or servicing of compressors, vacuum pumps and components will be carried out only if a correctly completed declaration has been submitted. Non-completion will result in delay. The manufacturer can refuse to accept any equipment without a declaration.

A separate declaration has to be completed for each single component.

This declaration may be completed and signed only by authorized and qualified staff.

Customer/Dep./Institute : _____ Address : _____ _____ Person to contact: _____ Phone : _____ Fax: _____ End user : _____	Reason for return: <input checked="" type="checkbox"/> applicable please mark <b>Repair:</b> <input type="checkbox"/> chargeable <input type="checkbox"/> warranty <b>Exchange:</b> <input type="checkbox"/> chargeable <input type="checkbox"/> warranty <input type="checkbox"/> Exchange already arranged / received <b>Return only:</b> <input type="checkbox"/> rent <input type="checkbox"/> loan <input type="checkbox"/> for credit <b>Calibration:</b> <input type="checkbox"/> DKD <input type="checkbox"/> Factory-calibr. <input type="checkbox"/> Quality test certificate DIN 55350-18-4.2.1
---	--

<b>A. Description of the product:</b>	<b>Failure description:</b>
Material description : _____	_____
Catalog number: _____	<b>Additional parts:</b> _____
Serial number: _____	<b>Application-Tool:</b> _____
Type of oil (ForeVacuum-Pumps) : _____	<b>Application- Process:</b> _____

<b>B. Condition of the equipment</b>	<b>No<sup>1)</sup></b>	<b>Yes</b>	<b>No</b>		<b>Contamination :</b>	<b>No<sup>1)</sup></b>	<b>Yes</b>
1. Has the equipment been used	<input type="checkbox"/>	<input type="checkbox"/>	<input type="checkbox"/>		toxic	<input type="checkbox"/>	<input type="checkbox"/>
2. Drained (Product/service fluid)	<input type="checkbox"/>	<input type="checkbox"/>	<input type="checkbox"/>		corrosive	<input type="checkbox"/>	<input type="checkbox"/>
3. All openings sealed airtight	<input type="checkbox"/>	<input type="checkbox"/>	<input type="checkbox"/>		flammable	<input type="checkbox"/>	<input type="checkbox"/>
4. Purged	<input type="checkbox"/>	<input type="checkbox"/>	<input type="checkbox"/>		explosive <sup>2)</sup>	<input type="checkbox"/>	<input type="checkbox"/>
If yes, which cleaning agent _____					radioactive <sup>2)</sup>	<input type="checkbox"/>	<input type="checkbox"/>
and which method of cleaning _____					microbiological <sup>2)</sup>	<input type="checkbox"/>	<input type="checkbox"/>
<sup>1)</sup> If answered with "No", go to D.					other harmful substances	<input type="checkbox"/>	<input type="checkbox"/>

**C. Description of processed substances (Please fill in absolutely)**

1. What substances have come into contact with the equipment ?  
 Trade name and / or chemical term of service fluids and substances processed, properties of the substances  
 According to safety data sheet (e.g. toxic, inflammable, corrosive, radioactive)

X	Tradename:	Chemical name:
a)		
b)		
c)		
d)		

2. Are these substances harmful ? **No**  **Yes**

3. Dangerous decomposition products when heated ? **No**  **Yes**

If yes, which ? \_\_\_\_\_

<sup>2)</sup> Components contaminated by microbiological, explosive or radioactive products/substances will not be accepted without written evidence of decontamination.

**D. Legally binding declaration**

I / we hereby declare that the information supplied on this form is accurate and sufficient to judge any contamination level.

Name of authorized person (block letters) : \_\_\_\_\_

\_\_\_\_\_

Date signature of authorized person

firm stamp



## A

Adapter 10, 13, 19, 25, 39, 54  
Adsorption trap 34, 40, 62  
Air cooler 6, 9-11, 16, 25, 27, 41  
Air cooling 8, 10, 12, 25, 27, 35, 36  
Ambient temperature 11, 12, 24, 35-37,  
43, 56, 65, 66  
Anti-suckback valve 34, 58

## B

Bakeout 3, 60  
Burns 7, 31

## C

Contamination 12, 63, 68  
Cooling 8-12, 16, 25-28, 35-38, 41, 43,  
44, 53, 56, 65, 66  
Cooling water 12, 28, 37, 38

## D

Danger of ignition 8  
Deposits 6, 22, 47, 61  
Desiccant 10, 21, 28, 61  
Dimensional drawings 14, 15  
Dripping or spraying water 6, 24  
Dust 7, 22, 30, 47, 59, 62

## E

Earthquake protection 29  
Emergency shut down 8, 43, 58

## F

Forevacuum connection 11, 28, 29, 34  
Forevacuum pressure 10, 11, 22, 34, 36,  
56, 60, 64-66  
Forevacuum pump 9, 11, 34, 40, 57, 58,  
60, 67  
Fuse 8, 42

## G

Generator 52, 54-56, 58, 66

## H

Hazardous gases 7, 34, 61  
Heat sink 19, 43, 52  
High-vacuum flange 16, 28, 29, 31  
Holweck stage 10  
Humidity 6, 7, 11, 12, 34, 37, 47

## I

Inlet screen 8, 10, 11, 20, 29, 30  
Interface 8, 16, 44, 48-51, 54, 57, 58,  
64, 67

## L

LED 8, 40, 44, 46, 50, 57, 58, 61, 67

## M

Magnetic field 24  
Mains power failure 52, 58, 66  
Media 7, 47, 58  
Motor temperature 48, 52, 53, 56, 64,  
66

## N

Nitrogen 39, 47

## O

Overpressure 5, 39  
Oxygen 22

## P

Particles 59  
PLC 42, 45  
Power supply 10, 12, 17, 18, 25, 28, 41-  
43, 48, 53, 56-58, 66, 67  
Pressure rise 59  
Purge gas and venting valve 10, 13, 19,  
25, 39, 40, 59, 62

## R

Radiation 23, 24, 60  
Relay 12, 45, 46, 48, 52, 53  
Resonance damper 29, 40  
Rotor 5, 7, 8, 10, 23, 28-31, 48, 52, 54,  
57-60, 62, 65, 67

## S

Safety valve 5, 34  
Shock 57  
Split-cage DC motor 10  
Starting pressure 57

## T

Temperature sensor 10, 66  
Torque 5, 7, 23, 28-33

## V

Venting valve 10, 13, 19, 25, 39, 40, 54,  
59  
Vibration 23, 28, 29, 57

# Sales and Service

## Germany

**Oerlikon**  
**Leybold Vacuum GmbH**  
Bonner Strasse 498  
D-50968 Cologne  
Phone: +49-(0)221-347 1234  
Fax: +49-(0)221-347 1245  
sales.vacuum@oerlikon.com  
www.oerlikon.com

**Oerlikon**  
**Leybold Vacuum GmbH**  
**Sales Area North/Northeast**  
Branch Office Berlin  
Industriestrasse 10b  
D-12099 Berlin  
Phone: +49-(0)30-435 609 0  
Fax: +49-(0)30-435 609 10  
sales.vacuum.bn@oerlikon.com

**Oerlikon**  
**Leybold Vacuum GmbH**  
**Sales Area South/Southwest**  
Branch Office Munich  
Karl-Hammerschmidt-Strasse 34  
D-85609 Aschheim-Dornach  
Phone: +49-(0)89-357 33 9-10  
Fax: +49-(0)89-357 33 9-33  
sales.vacuum.mn@oerlikon.com  
service.vacuum.mn@oerlikon.com

**Oerlikon**  
**Leybold Vacuum GmbH**  
**Sales Area West & Benelux**  
Branch Office Cologne  
Bonner Strasse 498  
D-50968 Cologne  
Phone: +49-(0)221-347 1270  
Fax: +49-(0)221-347 1291  
sales.vacuum.kn@oerlikon.com

**Oerlikon**  
**Leybold Vacuum GmbH**  
**Service Competence Center**  
Emil-Hoffmann-Strasse 43  
D-50996 Cologne-Suerth  
Phone: +49-(0)221-347 1439  
Fax: +49-(0)221-347 1945  
service.vacuum.kn@oerlikon.com

**Oerlikon**  
**Leybold Vacuum GmbH**  
**Mobil Customer Service**  
Emil-Hoffmann-Strasse 43  
D-50996 Cologne-Suerth  
Phone: +49-(0)221-347 1765  
Fax: +49-(0)221-347 1944  
service.vacuum.kn@oerlikon.com

**Oerlikon**  
**Leybold Vacuum**  
**Dresden GmbH**  
**Service Competence Center**  
Zur Wetterwarte 50, Haus 304  
D-01109 Dresden  
Service:  
Phone: +49-(0)351-88 55 00  
Fax: +49-(0)351-88 55 041  
info.vacuum.dr@oerlikon.com

**Oerlikon**  
**Leybold Vacuum USA Inc.**  
5700 Mellon Road  
USA-Export, PA 15632  
Phone: +1-724-327-5700  
Fax: +1-724-325-3577  
info.vacuum.ex@oerlikon.com

## Europe

Belgium  
**Oerlikon**  
**Leybold Vacuum Nederland B.V.**  
**Belgisch bijkantoor**  
Leuvensesteenweg 542-9A  
B-1930 Zaventem  
Sales:  
Phone: +32-2-711 00 83  
Fax: +32-2-720 83 38  
sales.vacuum.zv@oerlikon.com  
Service:  
Phone: +32-2-711 00 82  
Fax: +32-2-720 83 38  
service.vacuum.zv@oerlikon.com

France  
**Oerlikon**  
**Leybold Vacuum France S.A.**  
7, Avenue du Québec  
Z.A. de Courtaboeuf 1 - B.P. 42  
F-91942 Courtaboeuf Cedex  
Sales and Service:  
Phone: +33-1-69 82 48 00  
Fax: +33-1-69 07 57 38  
info.vacuum.ctb@oerlikon.com  
sales.vacuum.ctb@oerlikon.com

**Oerlikon**  
**Leybold Vacuum France S.A.**  
**Valence Factory**  
640, Rue A. Bergès  
B.P. 107 640  
F-26501 Bourg-lès-Valence Cedex  
Service:  
Phone: +33-4-75 82 33 00  
Fax: +33-4-75 82 92 69  
marketing.vacuum.vc@oerlikon.com

Great Britain

**Oerlikon**  
**Leybold Vacuum UK LTD.**  
Silverglade Business Park  
Leatherhead Road Unit 2  
KT9 2QL Chessington, Surrey  
(London)  
Sales:  
Phone: +44-13-7273 7300  
Fax: +44-13-7273 7301  
sales.vacuum.ln@oerlikon.com  
Service:  
Phone: +44-20-8971 7030  
Fax: +44-20-8971 7003  
service.vacuum.ln@oerlikon.com

Italy

**Oerlikon**  
**Leybold Vacuum Italia S.r.l.**  
Via Trasimeno 8  
I-20128 Milano  
Sales:  
Phone: +39-02-27 22 31  
Fax: +39-02-27 20 96 41  
sales.vacuum.mi@oerlikon.com  
Service:  
Phone: +39-02-27 22 31  
Fax: +39-02-27 22 32 17  
service.vacuum.mi@oerlikon.com

Netherlands

**Oerlikon**  
**Leybold Vacuum Nederland B.V.**  
Proostwetering 24N  
NL-3543 AE Utrecht  
Sales and Service:  
Phone: +31-(30) 242 6330  
Fax: +31-(30) 242 6331  
sales.vacuum.ut@oerlikon.com  
service.vacuum.ut@oerlikon.com

Spain

**Oerlikon**  
**Leybold Vacuum Spain, S.A.**  
C/ Huelva 7  
E-08940 Cornellà de Llobregat  
(Barcelona)  
Sales:  
Phone: +34-93-666 43 11  
Fax: +34-93-666 43 70  
sales.vacuum.ba@oerlikon.com  
Service:  
Phone: +34-93-666 46 16  
Fax: +34-93-685 43 70  
service.vacuum.ba@oerlikon.com

Sweden

**Oerlikon**  
**Leybold Vacuum Scandinavia AB**  
Box 9084  
SE-40092 Göteborg  
Sales and Service:  
Phone: +46-31-68 84 70  
Fax: +46-31-68 39 39  
info.vacuum.gt@oerlikon.com  
sales.vacuum.gt@oerlikon.com  
Visiting/delivery address:  
Datavägen 57B  
SE-43632 Askim

Switzerland

**Oerlikon**  
**Leybold Vacuum Schweiz AG**  
Leutschenbachstrasse 55  
CH-8050 Zürich  
Sales:  
Phone: +41-44-308 40 50  
Fax: +41-44-302 43 73  
sales.vacuum.zh@oerlikon.com  
Service:  
Phone: +41-44-308 40 62  
Fax: +41-44-308 40 60  
service.vacuum.zh@oerlikon.com

## America

USA

**Oerlikon**  
**Leybold Vacuum USA Inc.**  
5700 Mellon Road  
USA-Export, PA 15632  
Phone: +1-724-327-5700  
Fax: +1-724-325-3577  
info.vacuum.ex@oerlikon.com  
Sales:  
Eastern & Central time zones  
Phone: +1-724-327-5700  
Fax: +1-724-333-1217  
Pacific, Mountain, Alaskan &  
Hawaiian time zones  
Phone: +1-408-436-2828  
Fax: +1-408-436-2849  
Service:  
Phone: +1-724-327-5700  
Fax: +1-724-325-3577

Latin America

**Oerlikon**  
**Leybold Vacuum USA Inc.**  
**Brazilian Office**  
Av. Dória 360 cj. 12 Campo Belo  
04635-070 São Paulo SP BRAZIL  
Sales:  
Phone: +55 11-3554 3117  
Fax: +55 11-3554 3117  
nelson.batistucci@oerlikon.com

**Oerlikon**  
**Leybold Vacuum GmbH**  
Bonner Strasse 498  
D-50968 Cologne  
Phone: +49-(0)221-347 0  
Fax: +49-(0)221-347 1250  
info.vacuum.ex@oerlikon.com

## Asia

P.R. China

**Oerlikon**  
**Leybold Vacuum (Tianjin)**  
**International Trade Co. Ltd.**  
Beichen Economic  
Development Area (BEDA),  
No.8 Western Shuangchen Road  
Tianjin 300400  
China  
Sales and Service:  
Phone: +86-22-2697 0808  
Fax: +86-22-2697 4061  
Fax: +86-22-2697 2017  
info.vacuum.tj@oerlikon.com  
sales.vacuum.tj@oerlikon.com  
service.vacuum.tj@oerlikon.com

**Oerlikon**  
**Leybold Vacuum**  
**(Tianjin) Co. Ltd.**  
Beichen Economic  
Development Area (BEDA),  
No.8 Western Shuangchen Road  
Tianjin 300400  
China  
Sales and Service:  
Phone: +86-22-2697 0808  
Fax: +86-22-2697 4061  
info.vacuum.tj@oerlikon.com  
sales.vacuum.tj@oerlikon.com  
service.vacuum.tj@oerlikon.com

**Oerlikon**  
**Leybold Vacuum (Tianjin)**  
**International Trade Co. Ltd.**  
Shanghai Branch:  
No.33  
76 Fu Te Dong San Road  
Waigaoqiao Free Trade Zone  
Shanghai 200131  
China  
Sales and Service:  
Phone: +86-21-5064-4666  
Fax: +86-21-5064-4668  
info.vacuum.sh@oerlikon.com  
sales.vacuum.sh@oerlikon.com  
service.vacuum.sh@oerlikon.com

**Oerlikon**  
**Leybold Vacuum (Tianjin)**  
**International Trade Co. Ltd.**  
Guangzhou Office and  
Service Center  
1st F, Main Building  
Science City Plaza,  
No.111 Science Revenue,  
Guangzhou Science City  
(GZSC) 510663, Guangzhou,  
China  
Sales:  
Phone: +86-20-223 23 980  
Fax: +86-20-223 23 990  
info.vacuum.gz@oerlikon.com  
sales.vacuum.gz@oerlikon.com  
service.vacuum.gz@oerlikon.com

**Oerlikon**  
**Leybold Vacuum (Tianjin)**  
**International Trade Co. Ltd.**  
Beijing Branch:  
1-908, Beijing Landmark Towers  
8 North Dongsanhuan Road  
Beijing 100004  
China  
Sales:  
Phone: +86-10-6590-7622  
Fax: +86-10-6590-7607  
sales.vacuum.bj@oerlikon.com  
service.vacuum.bj@oerlikon.com

India

**Oerlikon**  
**Leybold Vacuum India Pvt Ltd.**  
EL 22, J-Block  
MIDC Bhosari  
Pune 411026  
India  
Sales and Service:  
Phone: +91-20-3061 6000  
Fax: +91-20-2712 1571  
sales.vacuum.pu@oerlikon.com  
service.vacuum.pu@oerlikon.com

**Oerlikon**  
**Leybold Vacuum Taiwan Ltd.**  
No 416-1, Sec. 3  
Chunghsin Road., Chutung  
Hsinchu County 310  
Taiwan, R.O.C.  
Sales and Service:  
Phone: +886-3-500 1688  
Fax: +886-3-583 3999  
sales.vacuum.sg@oerlikon.com  
service.vacuum.sg@oerlikon.com

Japan

**Oerlikon**  
**Leybold Vacuum**  
**Japan Co., Ltd.**  
Headquarter  
23-3, Shin-Yokohama  
3-chome  
Tobu A.K. Bldg. 4th Floor  
Kohoku-ku  
Yokohama-shi 222-0033  
Sales:  
Phone: +81-45-471-3330  
Fax: +81-45-471-3323  
info.vacuum.yh@oerlikon.com  
sales.vacuum.yh@oerlikon.com

**Oerlikon**  
**Leybold Vacuum**  
**Japan Co., Ltd.**  
Osaka Sales Office  
3F, Shin-Osaka Terasaki  
No.3 Bldg.  
1-5-28 Nishi-Miyahara  
Yodogawa-ku, Osaka-shi  
Osaka 532-0004  
Phone: +81-6-6399-6271  
Fax: +81-6-6399-6273  
info.vacuum.os@oerlikon.com  
sales.vacuum.os@oerlikon.com

**Oerlikon**  
**Leybold Vacuum**  
**Japan Co., Ltd.**  
Tsukuba Technical Service Center  
Kogyo Danchi  
21, Kasuminosato,  
Ami-machi, Inashiki-gun  
Ibaraki-ken, 300-0315  
Service:  
Phone: +81-298 89 2841  
Fax: +81-298 89 2838  
info.vacuum.iik@oerlikon.com  
sales.vacuum.iik@oerlikon.com

South Korea

**Oerlikon**  
**Leybold Vacuum Korea Ltd.**  
3F, Jellzone 2 Tower  
Jeongja-dong 159-4  
Bundang-gu Sungnam-si  
Gyeonggi-do  
Bundang 463-384, Korea  
Sales:  
Phone: +82-31 785 1367  
Fax: +82-31 785 1359  
sales.vacuum.bd@oerlikon.com  
Service:  
623-7, Upsung-Dong  
Cheonan-Si  
Chungcheongnam-Do  
Korea 330-290  
Phone: +82-41 589 3035  
Fax: +82-41 588 0166  
service.vacuum.cn@oerlikon.com

Singapore

**Oerlikon**  
**Leybold Vacuum**  
**Singapore Pte Ltd.**  
1 Science Park Road  
Singapore Science Park 2  
#02-12, Capricorn Building  
Singapore 117528  
Sales and Service:  
Phone: +65-6303 7000  
Fax: +65-6773 0039  
sales.vacuum.sg@oerlikon.com  
service.vacuum.sg@oerlikon.com

Taiwan

**Oerlikon**  
**Leybold Vacuum Taiwan Ltd.**  
No 416-1, Sec. 3  
Chunghsin Road., Chutung  
Hsinchu County 310  
Taiwan, R.O.C.  
Sales and Service:  
Phone: +886-3-500 1688  
Fax: +886-3-583 3999  
sales.vacuum.sg@oerlikon.com  
service.vacuum.sg@oerlikon.com

**oerlikon**  
**leybold vacuum**  
**www.oerlikon.com/**  
**leyboldvacuum**