

# Instruction Manual

*iL Dry Pumping Systems*



Manor Royal, Crawley, West Sussex, RH10 9LW, UK  
Telephone: +44 (0) 1293 528844 Fax: +44 (0) 1293 533453  
<http://www.bocedwards.com>



# Declaration of Conformity

We, BOC Edwards,  
Manor Royal,  
Crawley,  
West Sussex RH10 2LW, UK

declare under our sole responsibility that the product(s)

iL Dry Pumping Systems:	iL70	iL600	iL70 <sup>†</sup>	iL600 <sup>†</sup>
460 V, 60 Hz, 3-phase	A533-71-908	A533-72-908	A533-74-908	A533-75-908
200/208 V, 50/60 Hz, 3-phase	A533-71-945	A533-72-945	A533-74-945	A533-75-945
380/415 V, 50 Hz, 3-phase	A533-71-946	A533-72-946	A533-74-946	A533-75-946
230 V, 60 Hz, 3-phase	A533-71-957	A533-72-957	A533-74-957	A533-75-957

† Sensor Configured Systems

to which this declaration relates is in conformity with the following standard(s)  
or other normative document(s)

EN50081-2	Electromagnetic Compatibility, General Emission Standard. Generic Standard Class: Industrial Environment.
EN50082-2	Electromagnetic Compatibility, General Immunity Standard. Generic Standard Class: Industrial Environment.
EN 60204-1	Electrical Safety; Machines.
EN 1012-2	Compressors and Vacuum Pumps - Safety Requirements; Part 2 - Vacuum Pumps.

following the provisions of

73/023/EEC	Low Voltage Directive.
89/336/EEC	Electromagnetic Compatibility Directive
98/37/EC	Machinery Safety Directive.



Dr. S. Ormrod, Technical Director



Date and Place

This product has been manufactured under a quality system registered to ISO9001

## iL Dry Pumping Systems - Setup Password

The setup password for this equipment is preset as follows:

SETUP PASSWORD:            202

You can remove this sheet from the instruction manual and retain it in a safe place to prevent unauthorised access to the setup menus in the iL system.

# CONTENTS

Section	Title	Page
1	INTRODUCTION	1-1
1.1	Scope and definitions	1-1
1.2	Overview	1-2
1.2.1	The iL system	1-2
1.2.2	Applications	1-2
1.3	The LCDP dry pump	1-4
1.4	The LCDP gas system (sensor-configured iL systems only)	1-4
1.5	The LCMB mechanical booster pump (iL600 only)	1-5
1.6	Temperature control system	1-5
1.6.1	LCDP pump temperature control system	1-5
1.6.2	LCMB pump temperature control system (iL600 only)	1-6
1.7	Exhaust system	1-7
1.8	Electrical system	1-7
1.8.1	Introduction	1-7
1.8.2	Electrics and Pump Control Module	1-7
1.8.3	Sensor Monitoring Module (sensor-configured iL systems only)	1-15
1.8.4	Gas Module (sensor-configured iL systems only)	1-15
1.9	Controls and indicators	1-15
1.10	Control functions	1-16
1.10.1	Priority of control	1-16
1.10.2	Setpoints, warning and alarm conditions	1-17
1.10.3	Safety sensors	1-17
1.11	Pump Display Module (optional accessory)	1-18
1.12	Accessories	1-20
2	TECHNICAL DATA	2-1
2.1	General	2-1
2.2	Performance	2-1
2.3	Temperature control system	2-9
2.4	Cooling-water supply	2-9
2.5	Lubrication	2-10
2.5.1	LCDP pump	2-10
2.5.2	LCMB pump (iL600 only)	2-10
2.6	Electrical data	2-10
2.7	Gas system (sensor-configured iL systems only)	2-11
2.8	Construction materials	2-11
2.9	Default setpoints	2-12
2.10	Connections	2-12
2.11	Item Numbers	2-14
2.11.1	Standard iL systems	2-14
2.11.2	Sensor-configured iL systems	2-14

Section	Title	Page
3	INSTALLATION	3-1
3.1	Safety	3-1
3.2	Installation checklist	3-1
3.3	Unpack and inspect	3-3
3.4	Remove the enclosure panels	3-6
3.5	Reconfigure the nitrogen and cooling-water connections (if required)	3-6
3.6	Locate the iL system	3-10
3.7	Check the pump oil-levels	3-11
3.7.1	iL70 systems	3-11
3.7.2	iL600 systems	3-11
3.8	Install or replace the Pump Display Module and other optional accessories (if necessary)	3-11
3.8.1	Install the Pump Display Module (optional)	3-11
3.8.2	Install other optional accessories	3-12
3.9	Connect the iL inlet to your vacuum system	3-12
3.10	Connect the iL exhaust outlet to your exhaust-extraction system	3-14
3.11	Connect to your factory extraction system (optional)	3-14
3.12	Connect the nitrogen supply (sensor-configured iL systems only)	3-15
3.13	Leak test the system	3-15
3.14	Install additional safety equipment (optional)	3-16
3.15	Connect to your emergency stop circuit (optional)	3-16
3.16	Electrical supply and RF earth (ground) connections	3-18
3.16.1	Reconfigure the iL system for your electrical supply (if necessary)	3-18
3.16.2	Reconfigure the pump(s) for your electrical supply (if necessary)	3-18
3.16.3	Connect the electrical supply to the iL system	3-20
3.16.4	Connect an additional RF earth (optional)	3-24
3.17	Refit the enclosure panels	3-24
3.18	Connect the cooling-water pipelines	3-25
3.19	Commission the iL system	3-26
3.19.1	Switch on an iL70 system	3-26
3.19.2	Configure and switch on an iL600 system	3-27
4	PUMP DISPLAY MODULE MENUS AND DISPLAY FORMATS	4-1
4.1	Introduction	4-1
4.2	General operation	4-2
4.3	The CANCEL button	4-3
4.4	Display text and variable text	4-3
4.5	Wrap-around	4-4
4.6	Timeout	4-4
4.7	Menu structure	4-4
4.8	Example	4-4

Section	Title	Page
5	OPERATION	5-1
5.1	Introduction	5-1
5.2	Change the display format	5-1
5.2.1	Change the normal display	5-1
5.2.2	Change the display units	5-2
5.3	Take and release control	5-2
5.4	Start-up	5-3
5.5	Check the nitrogen pressure and adjust if necessary (sensor-configured iL systems only)	5-4
5.6	Monitor the status of the iL system	5-4
5.7	Warning and alarm indications	5-6
5.8	Manual shut-down	5-6
5.8.1	Normal manual shut-down	5-6
5.8.2	Fast manual shut-down	5-7
5.9	Automatic shut-down	5-7
5.10	Emergency stop	5-8
5.11	Restart the LCMB pump after automatic pump shut-down (iL600 only)	5-8
5.12	Restart the iL system after emergency stop or automatic shut-down	5-9
5.13	Operation of iL system components	5-9
5.14	Operation of the load-lock pump	5-10
6	MAINTENANCE	6-1
6.1	Safety	6-1
6.1.1	General requirements	6-1
6.1.2	Recommended purge method	6-2
6.2	Correct use of Swagelok connectors	6-2
6.2.1	Fit a Swaelok connector	6-2
6.2.2	Reconnect Swagelok connector	6-4
6.3	Maintenance frequency	6-4
6.4	Inspect the connections, pipelines, cables and fittings	6-4
6.5	Inspect and clean the exhaust-pipe and check-valve	6-5
6.5.1	Dismantle, clean and refit the exhaust-pipe	6-5
6.5.2	Clean and refit the check-valve (if fitted)	6-6
6.6	Check the LCMB pump oil-level (iL600 only)	6-8
6.7	Check the LCDP pump oil-level	6-9
6.8	Change the LCDP pump oil	6-10
6.9	Change the LCMB pump oil (iL600 only)	6-11
6.10	Adjust the Pump Display Module display viewing angle (if fitted)	6-11
6.11	Replace a fuse	6-12
6.12	Replace the Pump Display Module	6-12
6.13	Relocate the iL system for maintenance	6-13
6.14	Fault finding	6-14
6.14.1	Warning and alarm message fault finding	6-14
6.14.2	Other fault finding	6-14
6.15	Check for free rotation of the LCDP pump	6-25

Section	Title	Page
7	STORAGE, DISPOSAL AND TRANSPORTATION	7-1
7.1	Storage	7-1
7.2	Disposal	7-1
7.3	Transportation	7-2
8	SERVICE, SPARES AND ACCESSORIES	8-1
8.1	Introduction	8-1
8.2	Service	8-1
8.3	Spares	8-2
8.4	Ordering Accessories	8-2
8.4.1	iL Enclosure Extraction Fan Kit	8-2
8.4.2	Pump Display Module	8-2
8.4.3	iL Pump Display Module extension cables	8-2
8.4.4	Active Gauge Connection Kit (sensor-configured iL systems only)	8-3
8.4.5	iL Interface Modules	8-3
8.4.6	iL PC Interface Kits	8-3
8.4.7	iL Central Monitoring System	8-4
8.4.8	iL600 Pressure Control Kit (sensor-configured iL systems only)	8-4
8.4.9	iL Communications Module	8-4
8.4.10	iL Alternative Nitrogen Connection Kit	8-4

#### RETURN OF BOC EDWARDS EQUIPMENT

## Tables

Table	Title	Page
1-1	Safety sensors	1-18
2-1	Technical data	2-2
2-2	Full load current ratings	2-11
2-4	Sensor Monitoring Module default setpoints (sensor-configured iL systems only)	2-13
2-5	Gas Module default setpoints (sensor-configured iL systems only)	2-13
3-1	Installation checklist	3-2
3-2	Checklist of components	3-4
3-3	Pins in the iL Tool Interface Module plug	3-16
3-4	Pins in the electrical supply connector	3-22
4-1	Menu structure	4-5
5-1	Status menu display options	5-5
6-1	Warning messages	6-15
6-2	Alarm messages	6-20
6-3	Fault messages	6-22
6-4	Fault parameters	6-23
6-5	Fault types	6-26

## Illustrations

Figure	Title	Page
1-1	The iL system (iL600 shown, with side panels removed)	1-3
1-2	Schematic diagram of the LCDP pump gas system (sensor-configured iL systems only)	1-5
1-3	Schematic diagram of the electrical system	1-9
1-4	Services and electrical connections on the rear of the iL system	1-12
1-5	Electrical components (shown without enclosure for clarity)	1-14
1-6	Controls and indicators on the front panel	1-16
1-7	Front panel of the Pump Display Module (optional accessory)	1-20
2-1	iL70 dimensions (mm)	2-3
2-2	iL600 dimensions (mm)	2-4
2-3	Services connections dimensions (mm)	2-5
2-4	Centre of mass dimensions (mm) and mass distribution	2-6
2-5	Typical pumping speeds for iL70: pumping speed against pressure	2-7
2-6	Typical pumping speeds for iL600: pumping speed against pressure	2-7
2-7	iL70 power curves: electrical power input against inlet pressure	2-8
2-8	iL600 power curves: electrical power input against inlet pressure	2-8
3-1	Remove the iL system from the pallet	3-4
3-2	Lifting-bolt positions	3-5
3-3	Remove/refit the enclosure panels	3-7
3-4	Reconfigure the cooling-water connections (if required)	3-9
3-5	Remove the vibration isolator transit brackets	3-10
3-6	Fit the Pump Display Module (optional accessory)	3-13
3-7	Leak-test port position	3-17
3-8	Reconfigure the iL system for your electrical supply (if necessary)	3-19
3-9	Reconfigure the pump-motor terminal-box (if necessary)	3-21
3-10	Connect the electrical supply cable to the connector mating-half	3-23
4-1	Front panel of the Pump Display Module (optional accessory)	4-2
4-2	Menu logic	4-6
4-3	Switch on menu	4-7
4-4	Switch off menu	4-8
4-5	Normal menu	4-9
4-6	Status menu: sheet 1 of 2	4-10
4-7	Control menu	4-12
4-8	Setup menu: sheet 1 of 3	4-13
4-9	Run til crash menu	4-16
4-10	Units menu	4-17
4-11	Normal display menu	4-18
4-12	Service menu: sheet 1 of 2	4-19
4-13	Serial menu	4-21
4-14	Zero sensors menu	4-22
4-15	Gas valve control menu	4-23
4-16	Manual menu: sheet 1 of 3	4-24
4-17	View Status menu: sheet 1 of 2	4-27
4-18	Messages menu	4-29



## Illustrations (continued)

Figure	Title	Page
4-19	Warning and alarm messages menu	4-30
6-1	Fit a Swagelok fitting	6-3
6-2	Retighten a Swagelok fitting	6-3
6-3	Clean the exhaust check-valve	6-7
6-4	Try to turn the LCDP pump	6-24

# 1 INTRODUCTION

## 1.1 Scope and definitions

This manual provides installation, operation and maintenance instructions for the BOC Edwards iL70 and iL600 Dry Pumping Systems (abbreviated to iL system in the remainder of this manual). You must use the iL systems as specified in this manual.

Read this manual before you install and operate the iL system. Important safety information is highlighted as WARNING and CAUTION instructions; you must obey these instructions. The use of WARNINGS and CAUTIONS is defined below.

### WARNING

Warnings are given where failure to observe the instruction could result in injury or death to people.

### CAUTION

Cautions are given where failure to observe the instruction could result in damage to the equipment, associated equipment or process.

Throughout this manual, page, figure and title numbers are in the form 'S-N', where 'S' specifies the section and 'N' specifies the number of the page, figure or table in the section.

The units used throughout this manual conform to the SI international system of units of measurements. Also, throughout this manual, wherever nitrogen flow rates are specified, the abbreviation 'slm' is used to mean 'standard l.min<sup>-1</sup>': this is a flow of 1 l.min<sup>-1</sup> at an ambient temperature of 0 °C and a pressure of 1013 mbar (1.013 x 10<sup>5</sup> Pa).

The following symbols may appear on the iL system:



Caution - refer to accompanying documentation.

PE Protective earth (ground)



Caution - risk of electric shock.

RF earth (ground)



Caution - hot surfaces.



Caution - static sensitive devices.

## 1.2 Overview

### 1.2.1 The iL system

The iL system operates at pressures between atmospheric and ultimate vacuum with no lubricating or sealing fluid in the pumping chamber(s). This ensures a clean pumping system without back-migration of oil into the system being evacuated.

The iL70 system has an LCDP70 dry pump; the iL600 system has an LCDP70 dry pump, with an LCMB600 mechanical booster pump fitted to the inlet of the LCDP pump. Throughout the remainder of this manual, the LCDP70 pump is referred to as the LCDP pump and the LCMB600 pump is referred to as the LCMB pump.

Both the LCDP and LCMB pumps have enclosed, water-cooled motors. The iL system is therefore suitable for applications in clean environments where fan cooling is unacceptable.

Two versions of iL system are available, sensor-configured iL systems and standard iL systems:

Sensor-configured iL systems have: a gas system which introduces purge gas into the LCDP shaft-seals; temperature sensors; other accessories (as described in the remainder of this manual). Sensor-configured iL systems are suitable for use on light duty processes.

Standard iL systems have no gas system, temperature sensors or other accessories. Standard iL systems are suitable for use on clean duty processes.

The iL system is designed to operate as a sealed unit, chemicals passing through the pump being contained within the internal volume and separated from the external environment by a mechanical barrier. This barrier is made up of a number of components of different materials, (see Section 2.8), chosen to be resistant to attack by chemicals usually found in clean applications.

Pumping a chemical that will aggressively attack any of these barrier materials may, over time, result in the internal contents of the pump becoming exposed to the external environment, which may constitute a safety hazard. If in doubt contact BOC Edwards who will advise you as to the suitability of this pump for any particular application.

It is also a feature of this pump design that the process gases are contained within the gearbox. If hazardous materials are being pumped special precautions must therefore be taken before the gearbox volume is accessed, details of this are given in Section 6. For this reason it is important to refer to this section before adding oil or opening the gearbox to atmosphere.

On sensor configured iL systems the purge gas acts as a barrier to protect the gearbox from process gas contamination. However, high pressure in exhaust pipe, exceeding that stated in section 2, could lead to gearbox contamination which will reduce the service life of product.

You can manually control the iL system through a Pump Display Module accessory: see Section 1.11. Alternatively, you can use your process tool or other control equipment to control the operation of the iL system through an Interface Module accessory (refer to Section 8.4.5), or through an iL Communications Module accessory (see Section 8.4.9), or you can use the iL Single Pumpset Monitor accessory to control the operation of the iL system (refer to Section 8.4.6). The remainder of this manual describes the use of the Pump Display Module to operate the iL

(Continued on page 1-4)

dcs/0017/001/iL

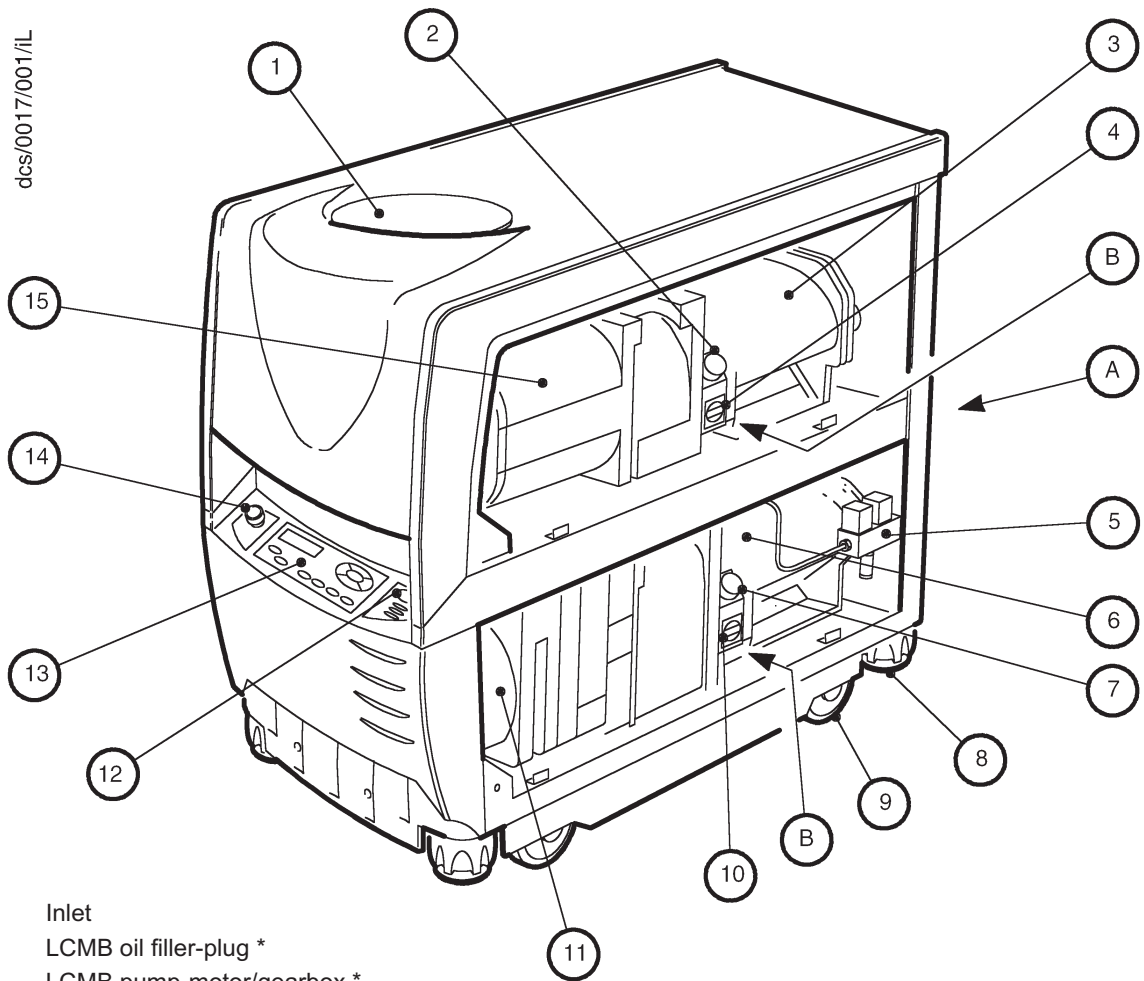

1. Inlet
2. LCMB oil filler-plug \*
3. LCMB pump-motor/gearbox \*
4. LCMB oil-level sight-glass \*
5. Gas Module †
6. LCDP pump-motor/gearbox
7. LCDP oil filler-plug
8. Levelling-foot
9. Castor
10. LCDP oil-level sight-glass
11. LCDP pump
12. Nitrogen pressure regulator †
13. Pump Display Module #
14. Emergency stop switch
15. LCMB pump \*

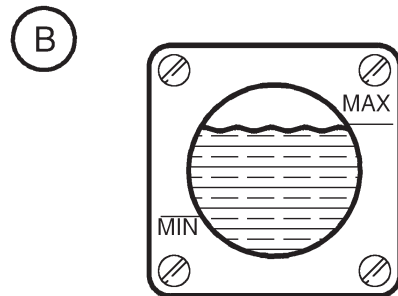
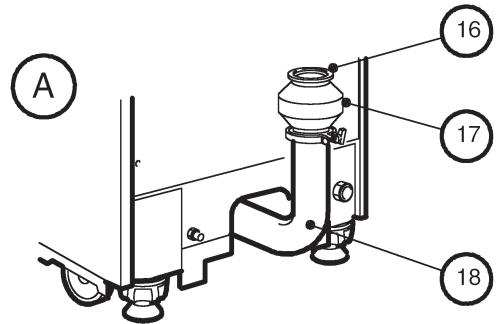

\* iL600 only

† Sensor-configured iL systems only

# Optional accessory

Figure 1-1 - The iL system (iL600 shown, with side panels removed)

system: for use of another accessory to operate the iL system, refer to the instruction manual supplied with the accessory.

All of the components of the iL system are fitted inside an enclosure. Panels of the enclosure can be removed for access to the pump(s) during maintenance.

The components of the iL system are described in Sections 1.3 onwards.

## 1.2.2 Applications

The iL system is suitable for use on clean and light duty applications, as described in Section 1.2.1. If you use the iL system to pump gases that will aggressively attack any of the internal components of the pump(s), this may eventually damage the pump(s), and result in the leakage of gases from the iL system, or the leakage of air into the iL system; such leaks may constitute a safety hazard. The iL system has no purge facility in the swept volume, therefore the iL system must not be used to pump any gases that require dilution to ensure their safety.

Pumped process gases will be contained within the pump gearbox(es). Normal purge procedures will purge the swept volume(s) of the pump(s), but will not purge the gearbox(es); each gearbox is effectively a trapped volume.

For this reason:

If you use the iL system to pump dangerous gases, you must take special precautions before you remove the oil filler-plugs: refer to Section 6.1.2.

You must **not** use the iL system in an application where incompatible gases are pumped, one after the other. If you do, the gases will mix in the gearbox(es).

If you use the iL system on an application for which it is not suitable, you may invalidate your warranties. If in doubt, contact BOC Edwards who will advise you as to the suitability of the iL system for any particular application.

## 1.3 The LCDP dry pump

The LCDP pump is a five-stage, positive displacement rotary pump in which pairs of intermeshing rotors (of different profiles mounted on common shafts) are held in correct phase relation by a pair of timing-gears. The timing-gears and the adjacent deep-groove ball-bearings, are oil lubricated.

## 1.4 The LCDP gas system (sensor-configured iL systems only)

The LCDP pump in a sensor-configured iL system has a gas system which makes the iL system suitable for use in light duty processes.

The gas system has supply pipelines and components (such as valves), a Gas Module with a pressure transducer, a solenoid-valve, and a pipeline which delivers purge nitrogen to the shaft-seals in the LCDP pump. The shaft-seals purge flow is on whenever the LCDP pump is on.

Refer to Figure 1-2 which shows a schematic diagram of the iL gas system.

The purge flow pressure is controlled by the pressure regulator (7), and the purge flow to the shaft-seals (2) is switched on and off by the solenoid-valve (5).

The pressure transducer (6) monitors the pressure of the shaft-seals purge flow. The output of the pressure transducer is used to display the shaft-seals purge pressure on the Pump Display Module (if fitted).

The front panel has two pressure status LEDs (Figure 1-6, items 4 and 5). These LEDs show whether the nitrogen supply pressure is too high, too low or is in the acceptable range: refer to Section 5.5.

## 1.5 The LCMB mechanical booster pump (iL600 only)

The LCMB pump is a positive displacement Roots vacuum pump. The pump mechanism is driven directly by a three-phase electric motor. The LCMB operates at inlet pressures of 5 mbar ( $5 \times 10^2$  Pa) and below, and is backed by the LCDP pump. When you start the LCDP pump, the iL system delays the start of the LCMB pump for a preset time, to allow the LCDP pump to reduce the pressure in the process system to below the maximum inlet pressure for the LCMB pump.

## 1.6 Temperature control system

### 1.6.1 LCDP pump temperature control system

The headplate, Fourth stage and High Vacuum stage of the LCDP pump have a direct cooling system in which water flows around these parts of the pump. All other stages of the pump are air-cooled by natural convection and radiation.

(Continued on page 1-6)

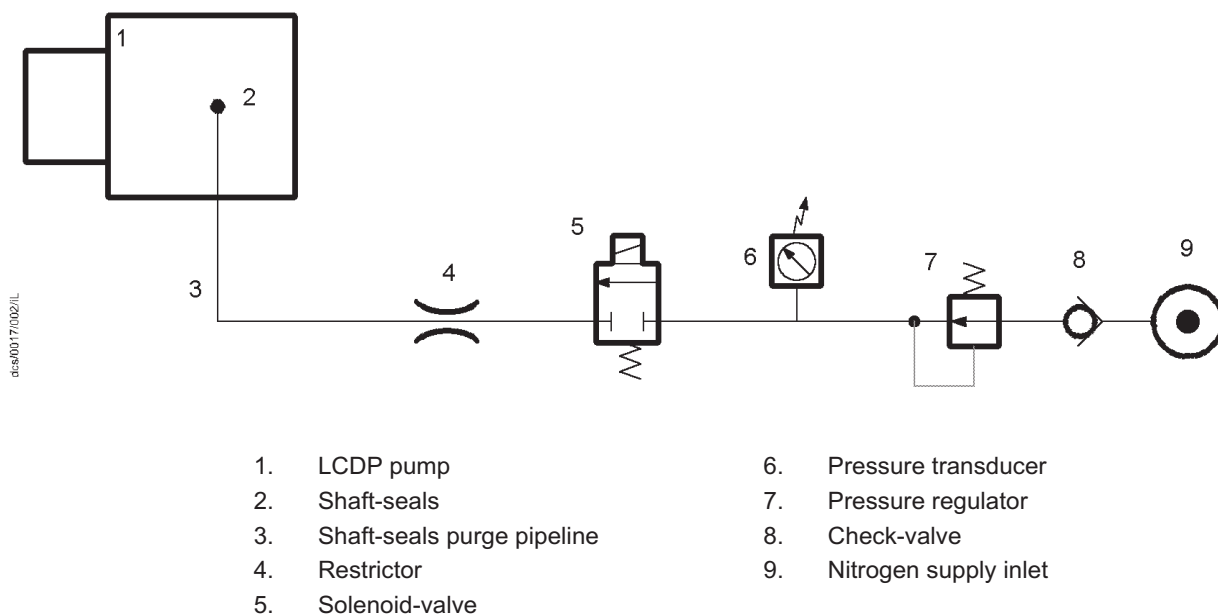

Figure 1-2 - Schematic diagram of the LCDP pump gas system (sensor-configured iL systems only)

The pump-motor is cooled by water which flows through a cooling jacket which surrounds the motor. The cooling-water supply and return pipelines are connected to the iL system by connectors on the end of the iL system (see Figure 1-4).

The cooling-water manifolds on the pump distribute the cooling-water to the pump cooling circuit and to the pump-motor cooling circuit (and to the LCMB pump-motor cooling circuit, on an iL600 system).

On sensor-configured iL systems only:

A thermocouple is fitted to the pump-body to measure the temperature of the pump-body. The output of the thermocouple is monitored by the iL system: see Section 1.8.3.

A surface temperature sensor (Figure 1-5, item 7) is fitted to the pump-motor water manifold. The output of the sensor is monitored by the iL system and is used to provide a warning of cooling system failure.

A water flow-switch is fitted in the pump-motor water manifold. The output of the flow-switch is monitored by the iL system and provides an indication of low water flow through the pump.

For safety reasons, a thermal snap-switch is fitted to the pump-motor water manifold block. The snap-switch opens at 60 °C. The snap-switch output is connected to the internal emergency stop circuit (see Section 1.10.3) and will shut down the iL system if the snap-switch has operated.

A motor-protection thermistor is fitted to the pump-motor. This thermistor is a solid-state device which has an electrical resistance of less than 750  $\Omega$  at normal pump-motor operational temperature. When the pump-motor is too hot, the electrical resistance rises quickly to >2000  $\Omega$ . The thermistor is connected to the emergency stop circuit to shut down the iL system if the pump-motor is too hot.

## 1.6.2 LCMB pump temperature control system (iL600 only)

The LCMB pump is cooled by ambient air. The pump-motor is cooled by water which flows through a cooling jacket which surrounds the pump-motor. The pump-motor cooling-water supply and return pipelines are connected to the cooling-water manifold on the LCDP pump.

On standard iL systems only, for safety reasons, a thermal snap-switch is fitted to the pump-stator. The snap-switch opens at 120 °C. The output of the snap-switch is connected to the internal control system and will temporarily switch off the LCMB pump and allow it to cool down if the snap-switch has operated.

On sensor-configured iL systems only, a temperature sensor probe (Figure 1-5, item 16) is fitted in the stator of the pump. The output of the sensor is monitored by the iL system and is used to provide a warning that the pump has been operating at maximum inlet pressure for longer than the specified time (see Table 2-1) and is overheating. If the temperature continues to rise, the internal control system will temporarily switch off the LCMB pump and allow it to cool.

A motor-protection thermistor is fitted to the pump-motor. This thermistor is identical to that fitted to the LCDP pump (see Section 1.6.1). The thermistor is connected to the internal control system and will temporarily switch off the LCMB pump and allow it to cool down if the pump-motor is too hot.

## 1.7 Exhaust system

The final stage of the LCDP pump is a positive displacement Roots stage, which attenuates the gas pressure pulses from the claw stages in the pump. This pump configuration reduces pump-induced resonance in your exhaust-extraction system and removes the need for an exhaust silencer.

The outlet of the LCDP pump is connected to an exhaust-pipe, which is below the pump. The outlet of the exhaust pipe has a check-valve which prevents the suck-back of exhaust vapours after the iL system is shut down. The check-valve also provides additional attenuation of the pulses in the exhaust pressure.

## 1.8 Electrical system

Refer to Figure 1-3 which shows a schematic diagram of the electrical and control system.

### 1.8.1 Introduction

The sensor-configured iL system has an Electrics and Pump Control Module (1), a Sensor Monitoring Module (3), a Gas Module (2), an optional Pump Display Module (4), sensors and accessories (see previous sections).

The standard iL system has an Electrics and Pump Control Module (1) and an optional Pump Display Module (4).

Optionally, the iL system may have an LCMB pump, an iL Interface Module, an iL Communications Module, and other accessories.

All of the Modules in the iL system communicate through a serial data network. Each Module on the network has a microprocessor, which controls the network communications and also contains the default setpoints for the sensors in or connected to the Modules (see Section 2).

### 1.8.2 Electrics and Pump Control Module

*Note: The operation of a safety sensor will have the same effect as the operation of the emergency stop switch: see Section 1.10.3.*

Refer to Figure 1-3. The external electrical supply (5) is connected to the electrical supply connector (6) on the Electrics and Pump Control Module (1). The Electrics and Pump Control Module switches the electrical supplies to the LCDP pump and to the LCMB pump (on an iL600 system) and monitors the operation of the pump(s). The Module also provides the electrical supplies to the other Modules in the iL system.

(Continued on page 1-10)



- |  |   |
|--|---|
| 1. Electrics and Pump Control Module         | 25. Emergency stop switch                                       |
| 2. Gas Module *                              | 26. Not used  |
| 3. Sensor Monitoring Module *                | 27. Gas Module and Sensor Monitoring Module electrical supply * |
| 4. Pump Display Module ▲                     | 28. LCMB temperature sensor <sup>#†</sup>                       |
| 5. External electrical supply                | 29. LCDP motor water manifold surface temperature sensor        |
| 6. Electrical supply connector               | 30. Shaft-seal pressure transducer *                            |
| 7. Protective earth (ground) stud            | 31. LCDP body thermocouple *                                    |
| 8. GRC relay connector <sup>#</sup>          | 32. Not used  |
| 9. Tool Interface Module connector           | 33. Not used  |
| 10. Control PCA                              | 34. Water flow-switch *   |
| 11. iL Tool Interface Module fuse holder     | 35. LON connector   |
| 12. Emergency stop fuse holder               | 36. Not used  |
| 13. LCDP electrical supply                   | 37. Not used  |
| 14. LCDP motor terminal-box                  | 38. 25-way 'D' type connector                                   |
| 15. LCDP motor thermistor cable              | 39. Solenoid-valve *  |
| 16. LCMB electrical supply <sup>†</sup>      | 40. Pressure transducers *                                      |
| 17. LCMB motor terminal-box <sup>†</sup>     | 41. Active gauge cable connector                                |
| 18. LCMB motor thermistor cable <sup>†</sup> | 42. Front panel LEDs  |
| 19. RF earth (ground) stud                   | 43. Front panel 10-way connector                                |
| 20. Cooling-fan connector                    | 44. 4-way XLR connector   |
| 21. Internal emergency stop loop             | 45. Active Gauge connector *                                    |
| 22. LCMB shut-down thermal snap-switch ▼     | 46. Rear panel  |
| 23. LCDP shut-down thermal snap-switch       | 47. d.c. electrical supply fuse holder                          |
| 24. Not used                                 |   |

\* Sensor-configured iL systems only.

† iL600 only.

▲ Optional accessory.

▼ Standard iL600 systems only.

# Not used on iL systems.

Figure 1-3 - Schematic diagram of the electrical system: key

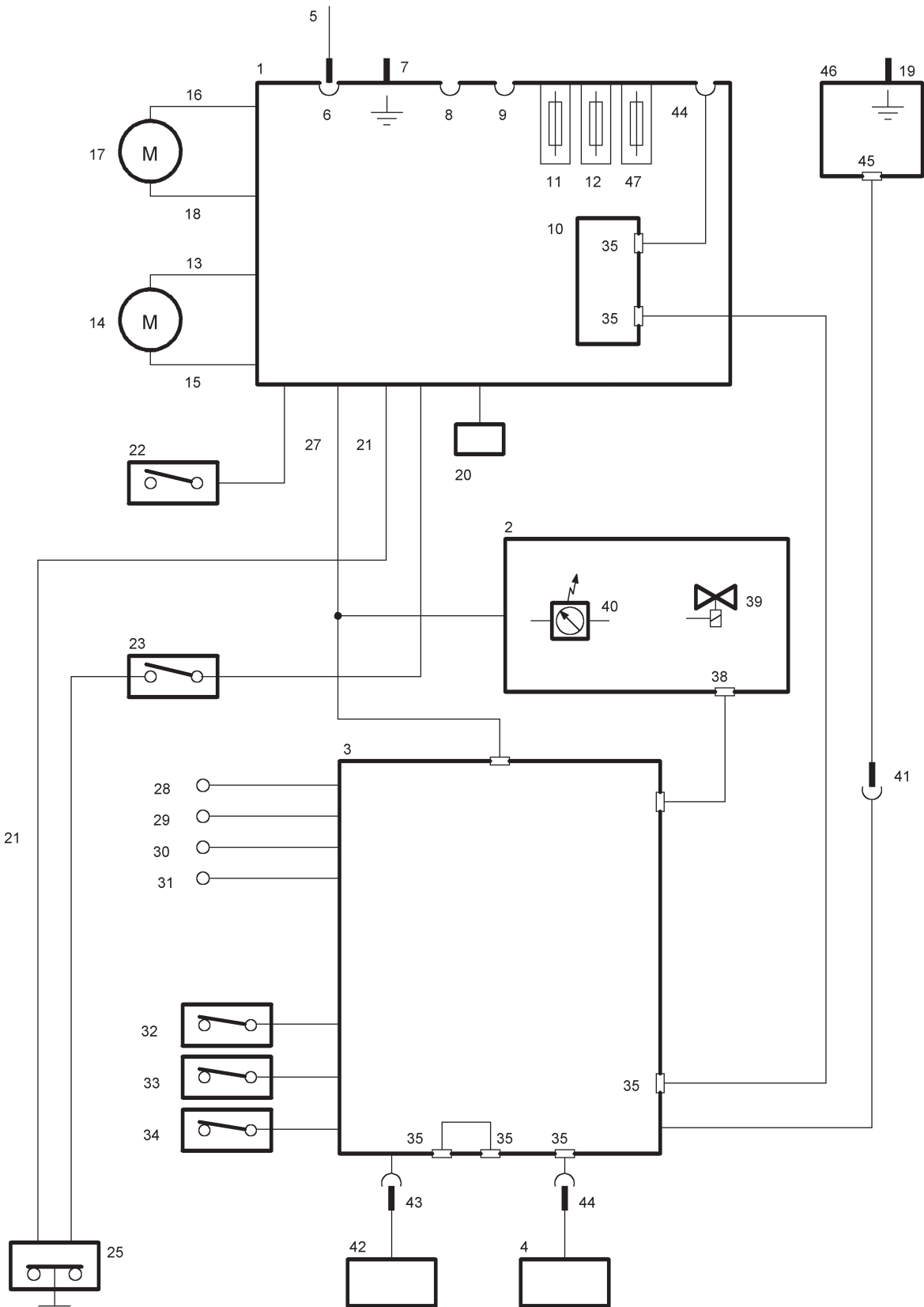

Figure 1-3 - Schematic diagram of the electrical system

The Module has contactors for the LCDP pump and the LCMB pump (on an iL600 system), pump power and current consumption sensors and short-circuit protection. Internal clocks and counters in the Module measure the operating time of the iL system and keep count of the number of iL system switch-on/switch-off and process cycles. The Module also has a transformer and fuses for the 24 V control circuits and fuses for the following supplies: iL Interface Module (11), emergency stop circuit (12) and d.c. electrical supply (47). Three thermal-type, self-resetting fuses in the Electrics and Pump Control Module protect the d.c. electrical supplies to the network.

Refer to Figure 1-4 detail D. The rear panel of the Electrics and Pump Control Module has the following lamp and connections:

Power on lamp (7)	This lamp is on when the electrical supply to the Electrics and Pump Control Module is on.
Tool Interface Module connector (8)	Use this to connect an iL Tool Interface Module to the iL system.
LON Interface Connector (9)	Use this to connect the iL system to a network.
Electrical supply connector (10)	Use this to connect your external electrical supply to the iL system: refer to Section 3.16.3.
Protective earth (ground) stud (11)	If required, use this to make additional protective earth (ground) connections: refer to Section 3.16.3.
GRC relay connector (12)	Not used on iL systems.
Fuse holder F7 (13)	This holds the fuse which protects the d.c. electrical supply.
Fuse holder F9 (14)	This holds the fuse which protects the emergency stop circuit.
Fuse holder F8 (15)	This holds the fuse which protects the iL Interface Module (if fitted).

Refer to detail E. Fuses inside the Module (16 to 21) protect the internal circuits of the Module. You cannot change these fuses; a BOC Edwards service engineer must change these fuses.

- 
- A iL70
  - B iL600
  - C Rear panel
  - D, E Detail of Electrics and Pump Control Module
- 
- 1. Blanking panel
  - 2. Cooling-water outlet
  - 3. Cooling-water inlet
  - 4. Nitrogen inlet \*
  - 5. Position of Active Gauge connector \*
  - 6. RF earth (ground) stud
  - 7. Power on lamp
  - 8. Tool Interface Module connector
  - 9. LON interface connector
  - 10. Electrical supply connector
  - 11. Protective earth (ground) stud
  - 12. GRC relay connector #
  - 13. d.c. electrical supply fuse holder (F7)
  - 14. Emergency stop fuse holder (F9)
  - 15. Tool Interface Module fuse holder (F8)
  - 16. Fuse F6
  - 17. Fuse F5
  - 18. Fuse F4
  - 19. Fuse F1
  - 20. Fuse F2
  - 21. Fuse F3
- \* Sensor-configured iL systems only
- † iL600 only
- # Not used on iL systems

Figure 1-4 - Services and electrical connections on the rear of the iL system: key

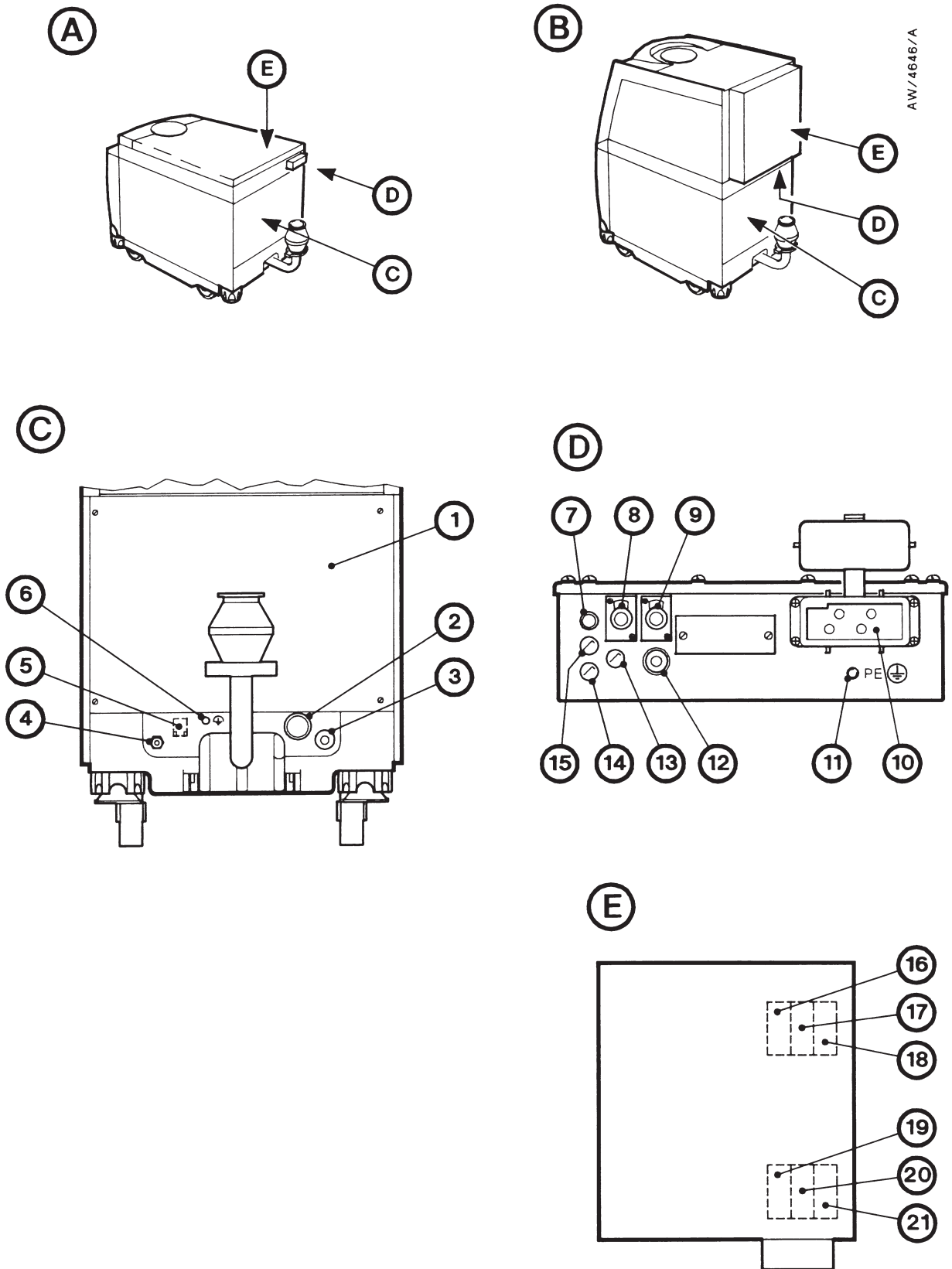

Figure 1-4 - Services and electrical connections on the rear of the iL system

Refer to detail C. The rear panel of the iL system has the following connections:

Active gauge connector (5) *	This connector is only available if you have fitted an Active Gauge Connection Kit (see Section 8.4.4). Use this to connect the active gauge to the iL system.
RF earth (ground) stud (6)	If required, use this to make additional RF earth (ground) connections: refer to Section 3.16.4.

Refer to Figure 1-5, detail A or B. The bottom panel of the Electrics and Pump Control Module has the following cables and connectors:

Internal EMS/Gas Module electrical supply cable (15)	This is used to connect the Module to the iL internal emergency stop circuit, and to provide the electrical supply to the Gas Module.
LCDP electrical supply cable (16)	This is used to connect the electrical supply from the Electrics and Pump Control Module to the LCDP pump.
LCDP thermistor cable (17)	This is used to connect the output of the thermistor in the LCDP pump to the Electrics and Pump Control Module.
Control Module cable (18)	This is used to connect the Electrics and Pump Control Module to the Sensor Monitoring Module.
LCMB thermistor cable (19)	On an iL600 system, this is used to connect the output of the thermistor in the LCMB pump to the Electrics and Pump Control Module.
LCMB electrical supply cable (20)	On an iL600 system, this is used to connect the electrical supply from the Electrics and Pump Control Module to the LCMB pump.

A	iL70 Electrics Module detail	B	iL600 Electrics Module detail
1.	LCMB pump †	11.	LCDP pump-body temperature sensor *
2.	LCMB pump-motor †	12.	LCDP pump
3.	LCMB pump-motor terminal-box †	13.	Sensor Monitoring Module
4.	iL600 Electrics Module †	14.	LCMB pump temperature sensor * or temperature snap-switch †
5.	LCDP pump-motor terminal-box	15.	Internal EMS/Gas Module electrical supply cable
6.	LCDP pump-motor water manifold temperature sensor *	16.	LCDP pump electrical supply cable
7.	LCDP pump thermal snap-switch	17.	LCDP pump-motor thermistor cable
8.	LCDP pump water flow-switch *	18.	LON network cable
9.	Gas Module *	19.	LCMB pump-motor thermistor cable †
10.	iL70 Electrics Module	20.	LCMB pump electrical supply cable †

\* Sensor-configured iL systems only  
† iL600 only

Figure 1-5 - Electrical components (shown without enclosure for clarity): key

dcsl0017/005/iL

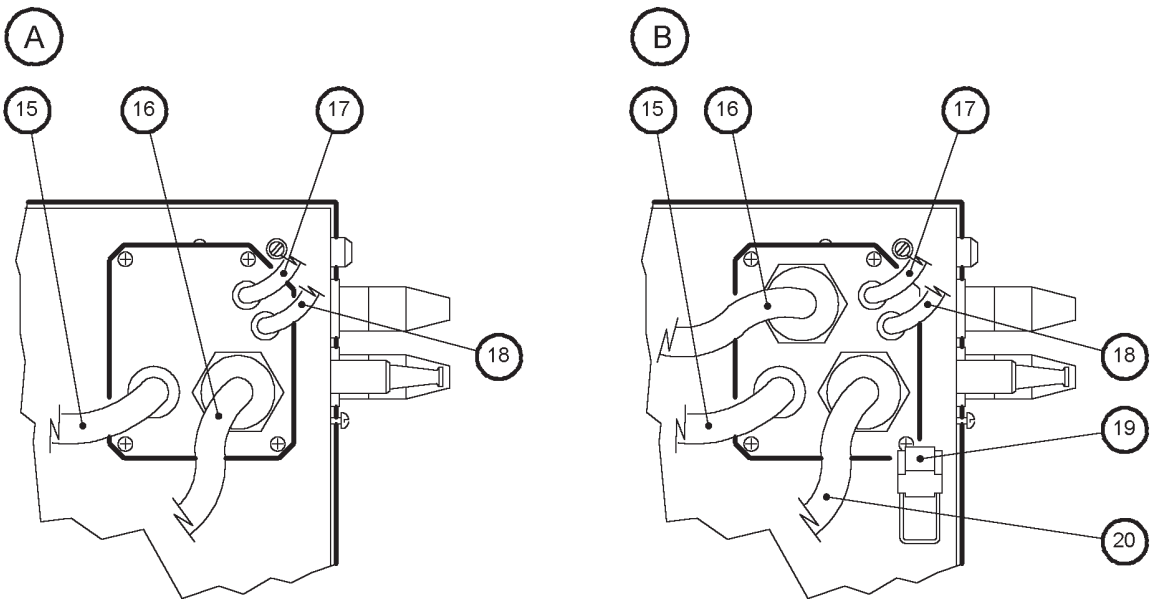
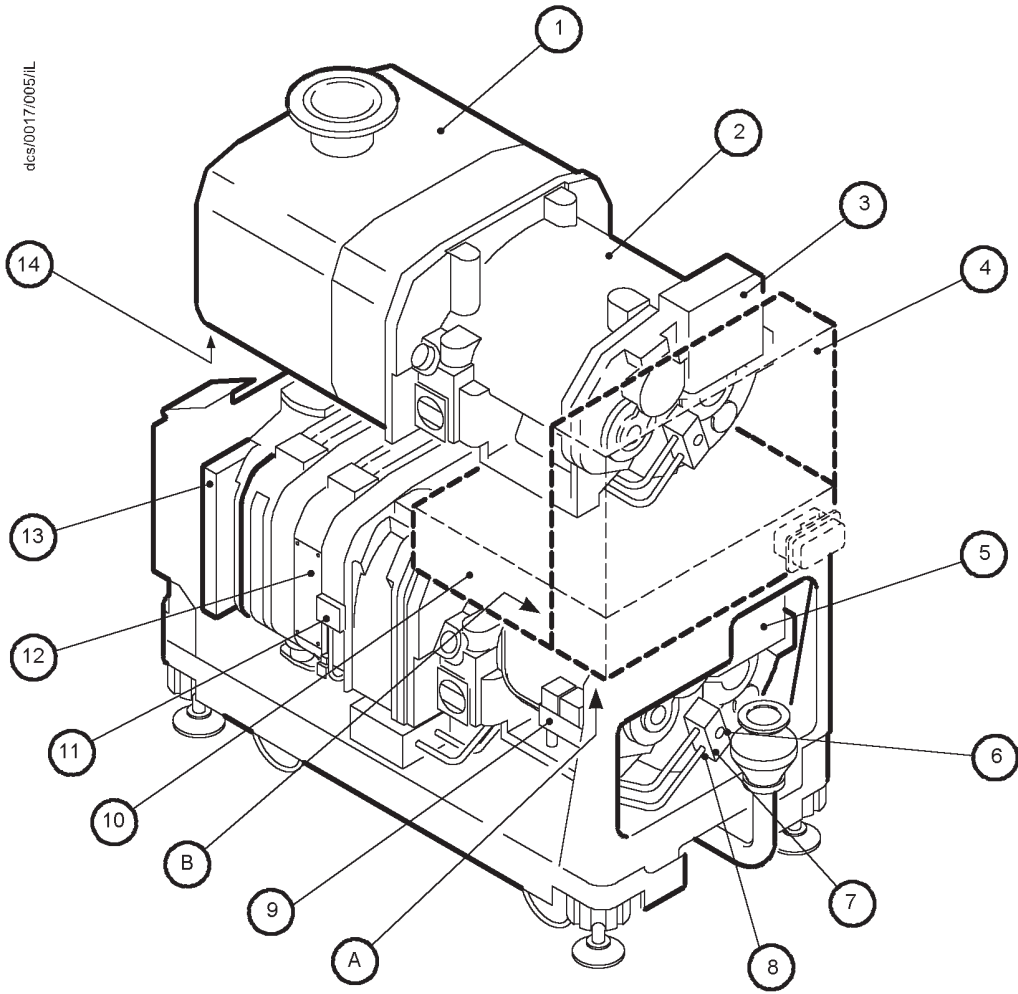

Figure 1-5 - Electrical components (shown without enclosure for clarity)

### 1.8.3 Sensor Monitoring Module (sensor-configured iL systems only)

This Module communicates with the Gas Module, the Pump Display Module (if fitted) and the optional Interface Module accessories. The following sensors are connected to the Sensor Monitoring Module:

LCDP pump-body and pump-motor water manifold temperature sensors (if fitted)

LCMB pump temperature sensor (iL600 systems only)

Water flow-switch.

The Module has a microprocessor which:

Monitors the status of the system.

Sends warning and alarm messages (see Section 1.10.2) to other Modules connected to the iL system.

Shuts down the iL system if a sensor reading is outside the specified alarm range: see Section 1.10.2. (Note that the safety sensors can also shut down the iL system; these sensors are not connected to the microprocessor: see Section 1.10.3.)

### 1.8.4 Gas Module (sensor-configured iL systems only)

The Gas Module communicates with the Sensor Monitoring Module.

## 1.9 Controls and indicators

Refer to Figure 1-6. The controls and indicators on the front panel of the iL system are as follows:

Emergency stop switch (1)	Press this to immediately shut down the iL system in an emergency: refer to Section 5.10.
Pump Display Module (2)	If fitted, use this optional accessory to control the iL system: refer to Section 1.11.
Nitrogen supply pressure regulator (3) *	Use this to adjust the nitrogen supply pressure.
Shaft-seal purge pressure high and low LEDs (4, 5) *	These green LEDs are both on when the shaft-seals purge nitrogen pressure is acceptable. The appropriate LED is off when the pressure is too high or too low.
Power OK LED (6)	This green LED is on when the internal 24 V electrical supply is on.
Running LED (7)	This green LED is on when the iL pumps are operating.

\* Sensor-configured iL systems only.



## 1.10 Control functions

### 1.10.1 Priority of control

The iL system can be controlled by a number of modules: the Pump Display Module (see Section 1.11); an iL Interface Module (see Section 8.4.5); or the iL Single Pumpset Monitor (see Section 8.4.7). Only one module can have control of the iL system at any one time. That is, once a module has control of the iL system, control requests from another Module are denied.

To allow another Module to control the iL system:

The Module which currently has control must 'release' control (that is, you must send the appropriate message on the network or press the appropriate button to release control).

Any Module which requires control must then 'take' control (that is, you must send the appropriate message to the iL system or press the appropriate button to take control).

Note that when you first switch-on the electrical supply, no Module will initially have control of the iL system. The Module which you want to control the iL system must take control as described above.

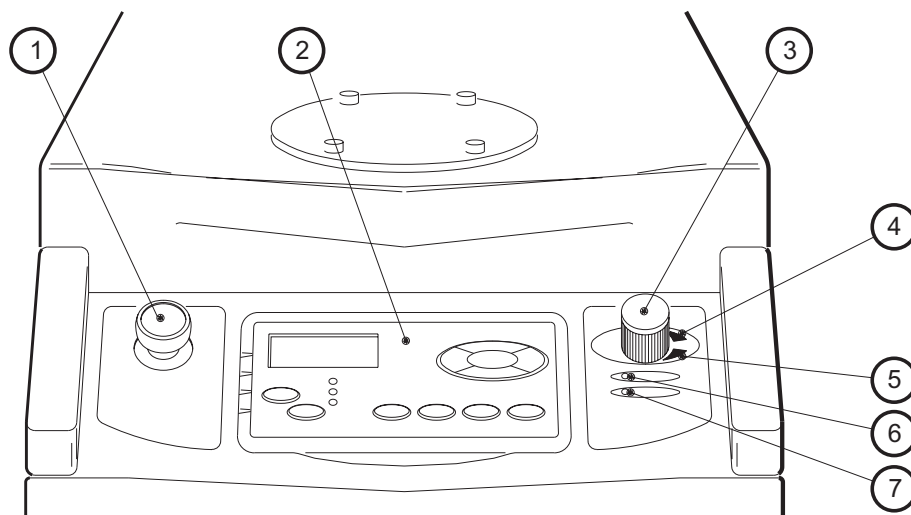

1. Emergency stop switch
2. Pump Display Module (optional accessory)
3. Nitrogen pressure regulator \*
4. Shaft-seals purge pressure high LED (green) \*
5. Shaft-seals purge pressure low LED (green) \*
6. Power OK LED (green)
7. Running LED (green)

\* Sensor-configured iL systems only

Figure 1-6 - Controls and indicators on the front panel

## 1.10.2 Setpoints, warning and alarm conditions

*Note: Sensors which generate alarm and warning messages are not safety sensors: see Section 1.10.3.*

Each Module which monitors sensors has a microprocessor. Each monitored sensor has four associated setpoints. The setpoints are: the low warning setpoint, the high warning setpoint, the low alarm setpoint and the high alarm setpoint. The microprocessor compares the sensor data to the setpoints to determine if an alarm or warning condition exists:

If the sensor data is below the low warning setpoint or above the high warning setpoint, a warning condition exists. A warning condition means that some aspect of the operation of the iL system is abnormal. The iL system will continue to operate.

If the sensor data is below the low alarm setpoint or above the high alarm setpoint, an alarm condition exists. An alarm condition means there is a serious fault which results in the shut-down of the iL system to prevent damage to the iL system. However, note that for some of the alarm conditions, you may be able to continue to operate the iL system if you have configured the iL system to 'run til crash': see Section 5.9.

If an alarm or warning condition exists, an appropriate alarm or warning message is displayed on the Pump Display Module and an appropriate alarm or warning indication is sent to other Modules on the network. Refer to Section 6 for a full list of the Pump Display Module warning and alarm messages.

You can use the default setpoints or you can use a Single Pumpset Monitor to adjust the setpoints to suit your application. Refer to Section 2 for the default setpoints.

## 1.10.3 Safety sensors

The LCDP pump has two safety sensors which are connected to the internal emergency stop circuit in the Electrics and Pump Control Module. If either of these safety sensors operate, it will have the same effect as the operation of the emergency stop switch described in Section 5.10, and the iL system is immediately shut down.

On iL600 systems, the LCMB pump has two safety sensors which are connected to the internal control system. If either of these safety sensors operate, the LCMB pump is temporarily switched off, to allow it to cool down.

Table 1-1 shows the safety sensors and the shutdown switch off conditions.

Safety sensor	Shut-down/switch off condition
LCDP pump-motor thermistor	When the thermistor in the LCDP pump-motor indicates that the temperature of the pump-motor is nominally 150 °C.
LCDP pump shut-down thermal snap-switch	When the thermal snap-switch operates to indicate that the temperature of the LCDP pump-motor manifold is 60 °C or higher.
LCMB pump-motor thermistor *	When the thermistor in the LCMB pump-motor indicates that the temperature of the pump-motor is nominally 150 °C.
LCMB pump shut-down thermal snap-switch * †	When the thermal snap-switch operates to indicate that the temperature of the LCMB pump-stator is 120 °C or higher.

\* iL600 only.

† On sensor configured iL600 systems, a temperature sensor is fitted instead of this snap-switch; the temperature sensor is monitored by the Sensor Monitoring Module.

Table 1-1 - Safety sensors

## 1.11 Pump Display Module (optional accessory)

The Pump Display Module accessory allows you to manually control the iL system and to display the status of the iL system. Refer to Figure 1-7 which shows the front panel of the Pump Display Module.

Use the On button (1) to switch on the iL system (refer to Section 5.4). The On button has a green LED which is on when the iL system is on. Use the Off button (10) to switch off the iL system (refer to Section 5.8).

The display (2) shows two lines of text; each line is 16 characters long. In normal operation, the Normal display is shown; the Normal display has two pages, and each page has two lines. Each page of the Normal display shows the current status of one or more iL system sensors or internal clocks and counters. As supplied:

The first page of Normal display shows LCDP pump power consumption and LCDP pump body temperature sensor ▲ values.

The second page shows LCMB pump power consumption and (on the iL600 only) LCMB pump-body temperature sensor ▲ values.

You can change the information shown on the Normal display: refer to Section 5.2.

At any time, you can press one of the four menu buttons (7) to select a new menu. You can then use the up (5), down (3), ENTER (6) and CANCEL (4) buttons to move through the menu. The appropriate menu selected LED (8) is on when the corresponding menu is in use.

(Continued on page 1-18)

▲ Sensor configured iL systems only.

Use the menu (7), up (5), down (3), CANCEL (4) and ENTER (6) buttons as described below. Refer to Section 4 for a full definition of the menu structures and the display formats.

<b>Button</b>	<b>LED colour</b>	<b>Button use</b>
Normal	Green	Press this button to select the Normal display (see above).
Control	Green	Press this button to select the Control menu. You can then take control or release control of the iL system (see Section 5.3).
Status	Green	Press this button to select the Status menu. In this menu, you can display the current values of all iL system sensors.
Setup	Green	Press this button to select the Setup menu. In this menu you can: manually control the operation of iL gas purges and gate valves fitted to the vacuum system (and connected to the iL through an iL Interface Module with an Auxiliary Interface Card); select 'Run til Crash'; change other display parameters (such as the pressure units used when pressures are displayed and the timeout time). The Setup menu also allows you to select the Service menu; in this menu, you can zero the Gas Module flow transducer and manually operate the components of the iL system.
ENTER	-	Use this button to select a currently displayed menu option or to enter a currently displayed parameter.
CANCEL	-	Use this button to cancel the currently displayed menu or option and return to the previous menu or option.
Up/down	-	Use these buttons to move up or down menu options or to increase or decrease a displayed parameter.

The status LEDs (9) show the current status of the iL system and the Pump Display Module:

<b>LED</b>	<b>LED colour</b>	<b>Meaning</b>
ALARM	Red	This LED shows when an alarm condition exists.
WARNING	Amber	This LED shows when a warning condition exists.
LOCAL CONTROL	Green	This LED is on when the Pump Display Module has control of the iL system.

## 1.12 Accessories

A number of accessories are available to configure the iL system for your specific application. Refer to Section 8.4 for descriptions of these accessories.

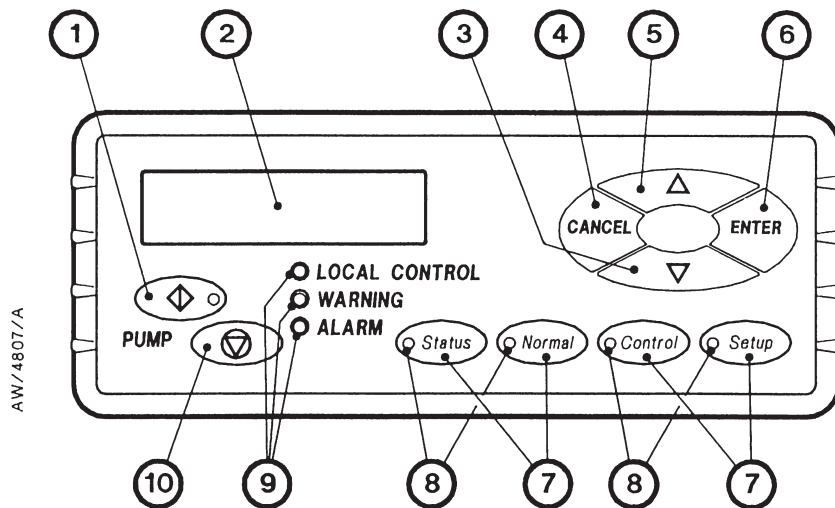

- |                  |                       |
|------------------|-----------------------|
| 1. On button     | 6. ENTER button       |
| 2. Display       | 7. Menu buttons       |
| 3. Down button   | 8. Menu selected LEDs |
| 4. CANCEL button | 9. Status LEDs        |
| 5. Up button     | 10. Off button        |

Figure 1-7 - Front panel of the Pump Display Module (optional accessory)

## 2 TECHNICAL DATA

Notes: Unless otherwise specified, data in the following sections applies to all models of iL system.

### 2.1 General

Dimensions	See Figures 2-1 to 2-3
Inlet and outlet	See Table 2-1
Warm-up time to nominal pumping performance	15 min
Minimum warm-up time to process gas pumping	3 hours
Vacuum system maximum leak-rate	$1 \times 10^{-5}$ mbar.l.s <sup>-1</sup> ( $1 \times 10^{-3}$ Pa.l.s <sup>-1</sup> )
Exhaust system maximum leak-rate	$1 \times 10^{-5}$ mbar.l.s <sup>-1</sup> ( $1 \times 10^{-3}$ Pa.l.s <sup>-1</sup> )
Ambient operating temperature range	5 to 40 °C
Maximum ambient operating humidity	90% RH
Maximum exhaust back pressure	3 p.s.i. (0.207 bar, $2.07 \times 10^4$ Pa)
Noise level measured at 1 m from the pump (with enclosure panels fitted)	
iL70	< 62 dB(A)
iL600	< 62 dB(A)
Mass	
iL70	230 kg
iL600	395 kg
Centre of mass	See Figure 2-4
Mass distribution	See Figure 2-4

### 2.2 Performance

Pumping speed range	See Figures 2-5 and 2-6
Power curves	See Figures 2-7 and 2-8
Peak pumping speed (nominal)	See Table 2-1
Ultimate vacuum	See Table 2-1
Maximum pressure differential between LCMB inlet and outlet *	See Table 2-1
Maximum inlet pressure *	See Table 2-1
Maximum operating time at maximum inlet pressure *	See Table 2-1

\* iL600 only

Parameter		Units	iL70	iL600
Typical peak pumping speed	50 Hz	m <sup>3</sup> h <sup>-1</sup>	70	518
	60 Hz	m <sup>3</sup> h <sup>-1</sup>	84	600
Ultimate vacuum	50 Hz	mbar	< 5 x 10 <sup>-2</sup>	< 3 x 10 <sup>-3</sup>
		Pa	< 5	< 3 x 10 <sup>-1</sup>
	60 Hz	mbar	< 3 x 10 <sup>-2</sup>	< 2 x 10 <sup>-3</sup>
		Pa	< 3	< 2 x 10 <sup>-1</sup>
Maximum pressure differential across LCMB pump *	50 Hz	mbar	-	70
		Pa	-	7 x 10 <sup>3</sup>
	60 Hz	mbar	-	70
		Pa	-	7 x 10 <sup>3</sup>
Maximum inlet pressure	50 Hz	mbar	-	See figure 2-6
		Pa	-	See figure 2-6
	60 Hz	mbar	-	See figure 2-6
		Pa	-	See figure 2-6
Maximum operating time at maximum inlet pressure *	50 Hz	hour	-	1
	60 Hz	hour	-	1
Inlet connection		-	ISO63 bolted	ISO100 bolted
Outlet connection		-	NW40	NW40

\* iL600 only

Table 2-1 - Technical data

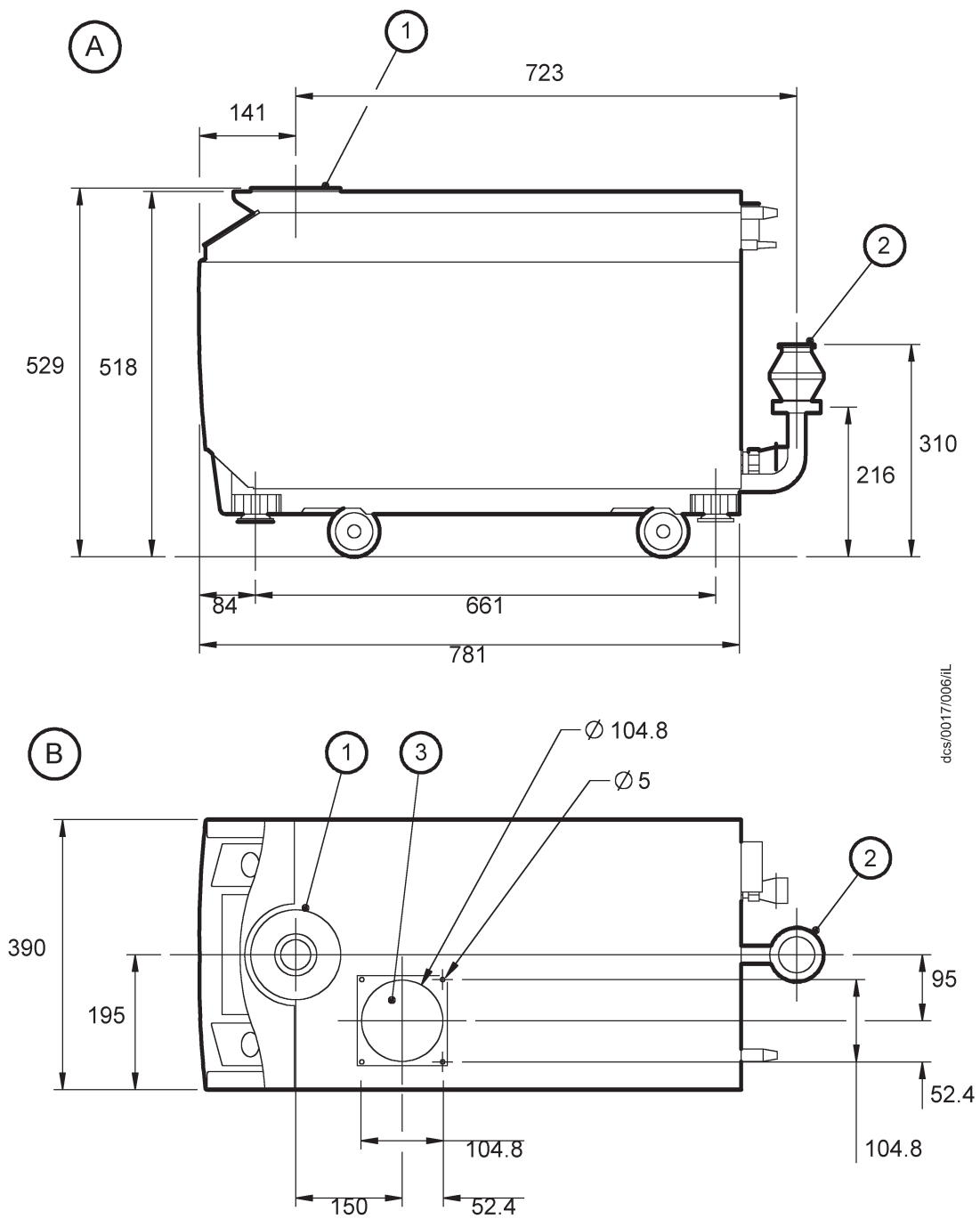

- A Side view  
 B Plan view
1. Inlet
  2. Outlet (as supplied)
  3. Air-extraction port

Figure 2-1 - iL70 dimensions (mm)



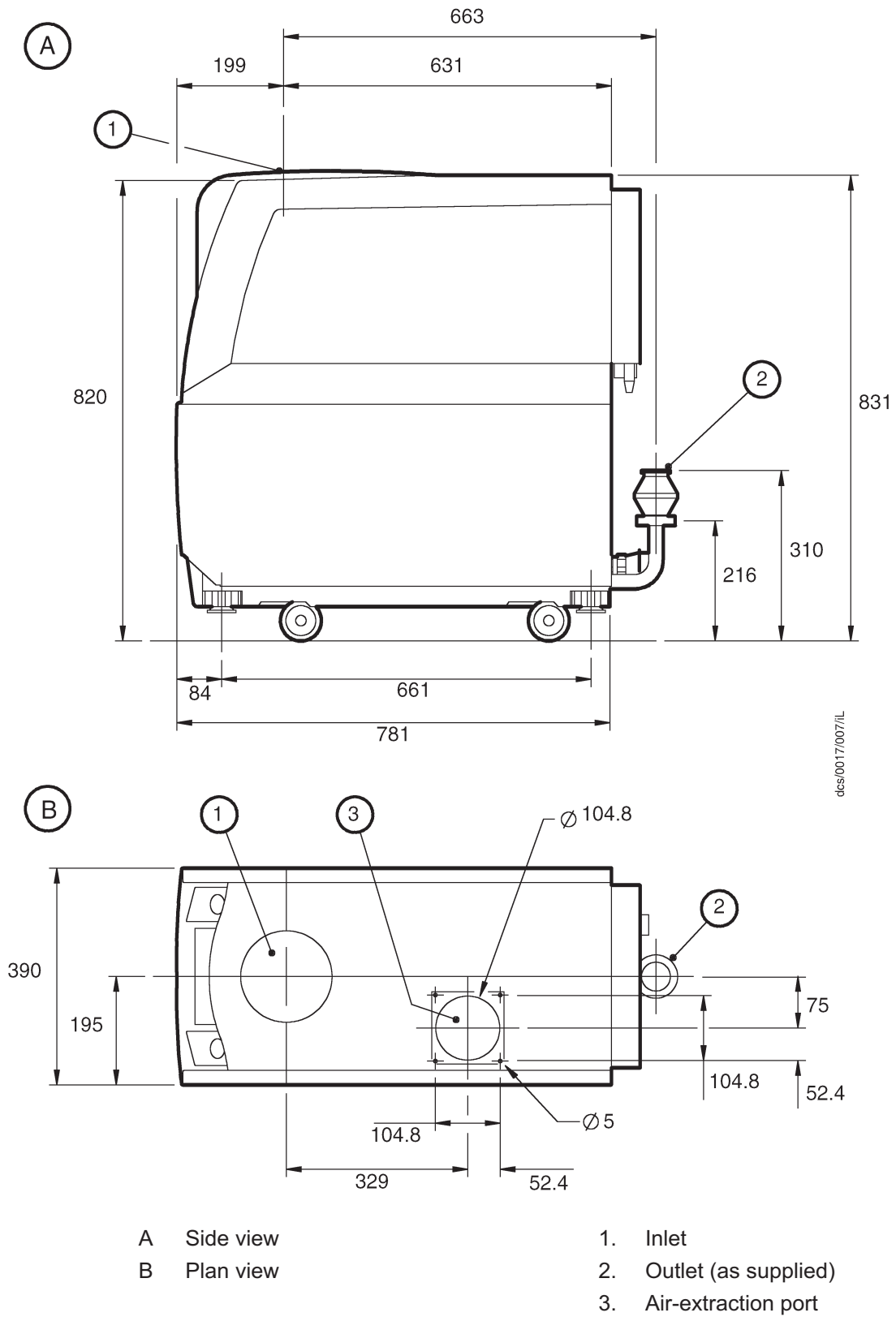
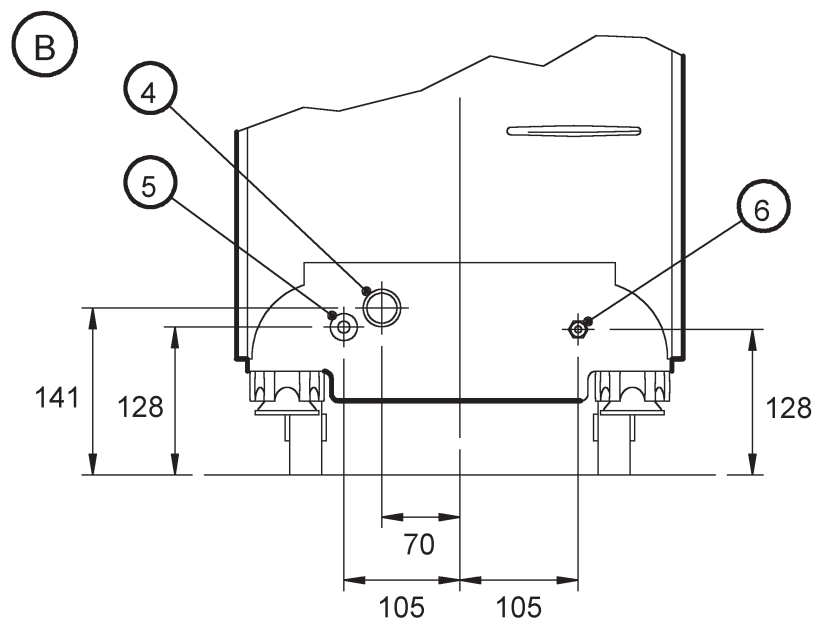
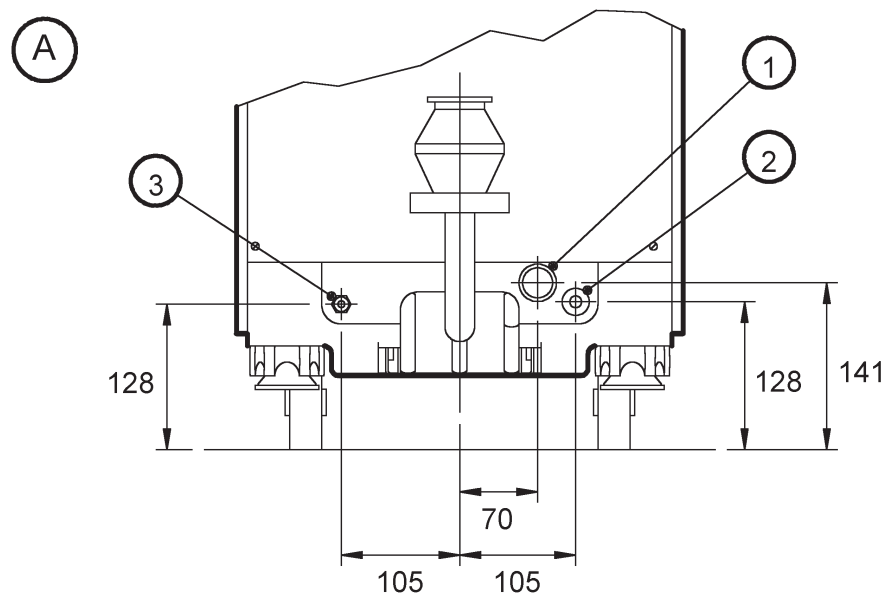

Figure 2-2 - iL600 dimensions (mm)



dcs/0017/008/iL

- |   |  |
|---|--|
| <p>A As supplied</p> <p>B Alternative positions</p> | <p>1. Cooling-water outlet (as supplied)</p> <p>2. Cooling-water inlet (as supplied)</p> <p>3. Nitrogen inlet: sensor-configured iL systems only (as supplied)</p> <p>4. Cooling-water outlet (alternative position)</p> <p>5. Cooling-water inlet (alternative position)</p> <p>6. Nitrogen inlet: sensor-configured iL systems only (alternative position)</p> |
|---|--|

Figure 2-3 - Services connections dimensions (mm)

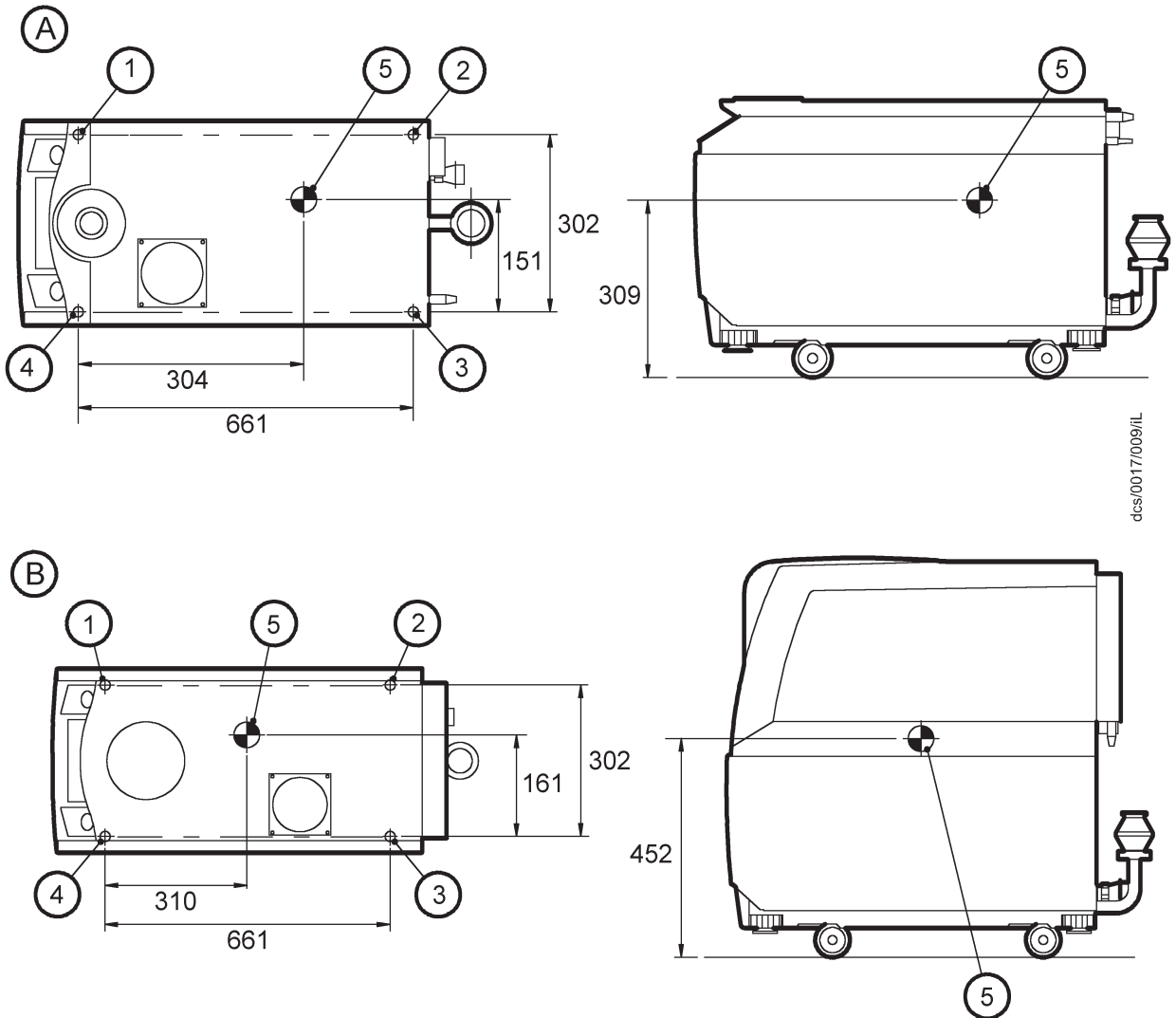

- A iL70
- B iL600

- 1. Levelling-foot
- 2. Levelling-foot
- 3. Levelling-foot
- 4. Levelling-foot
- 5. Centre of mass

	Mass distribution on levelling-feet (kg)			
	1	2	3	4
iL70	69	54.2	51.7	55.3
iL600	122.2	87.9	95.2	88

Figure 2-4 - Centre of mass dimensions (mm) and mass distribution

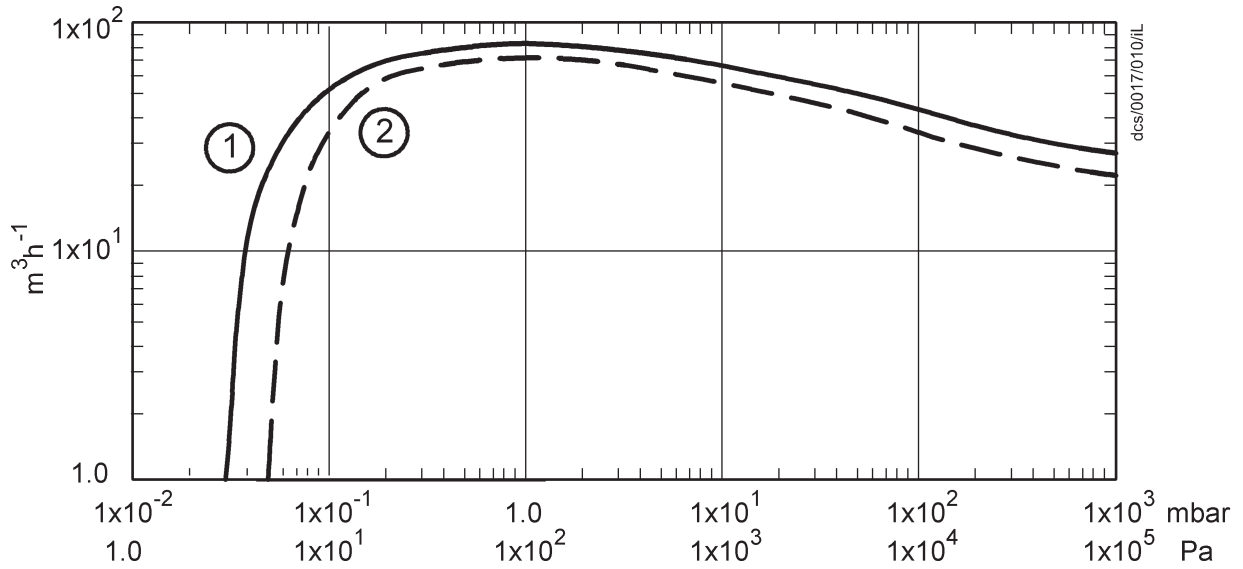

1. 60 Hz

Figure 2-5 - Typical pumping speeds for iL70: pumping speed against pressure

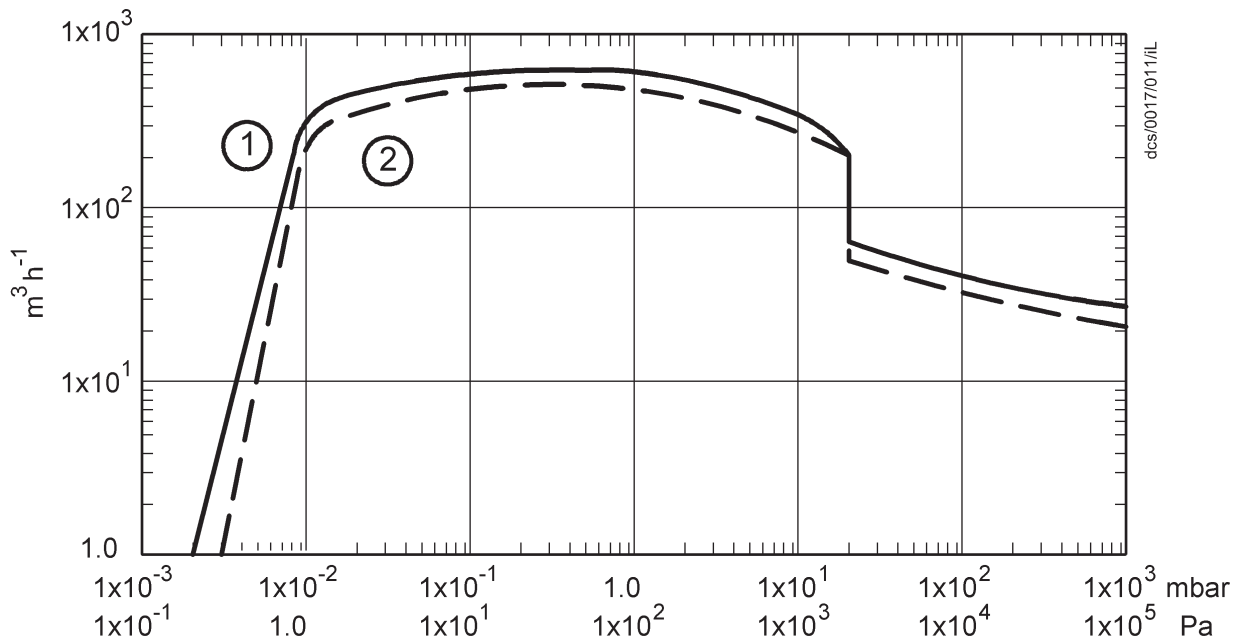

1. 60 Hz  
2. 50 Hz

Note: The discontinuity at inlet pressure of 20 mbar ( $2 \times 10^3$  Pa) indicates where the LCMB pump is automatically switched off: refer to Section 5.9.

Figure 2-6 - Typical pumping speeds for iL600: pumping speed against pressure

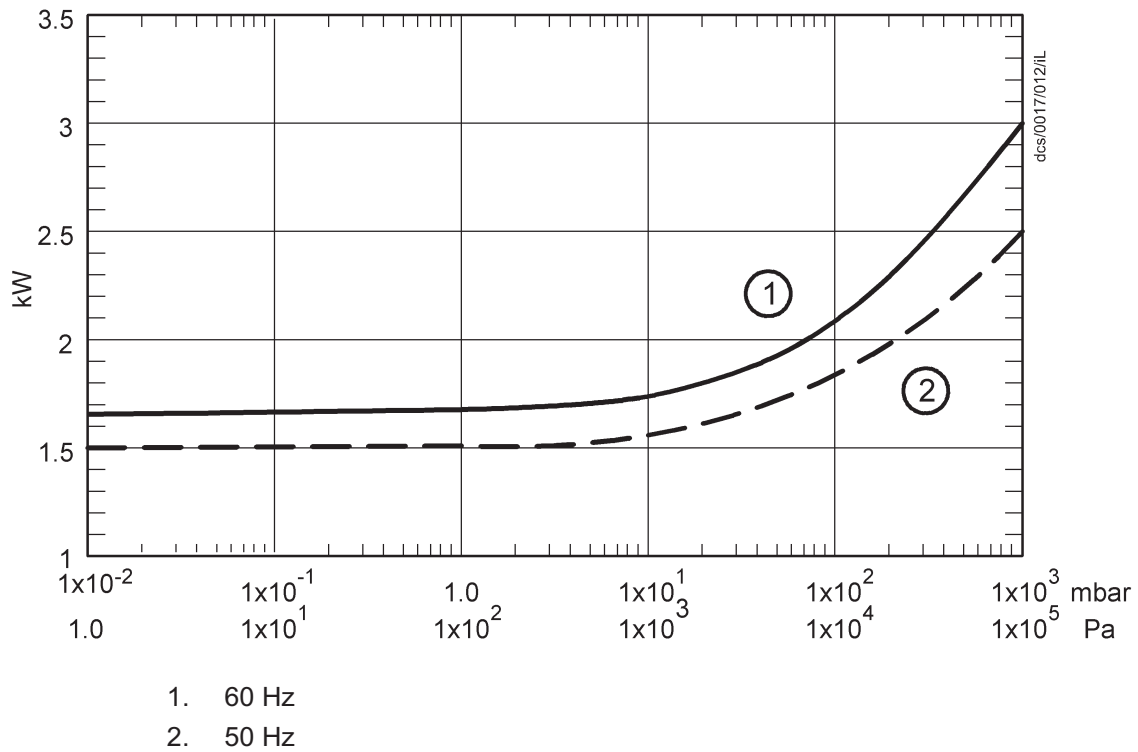

Figure 2-7 - iL70 power curves: electrical power input against inlet pressure

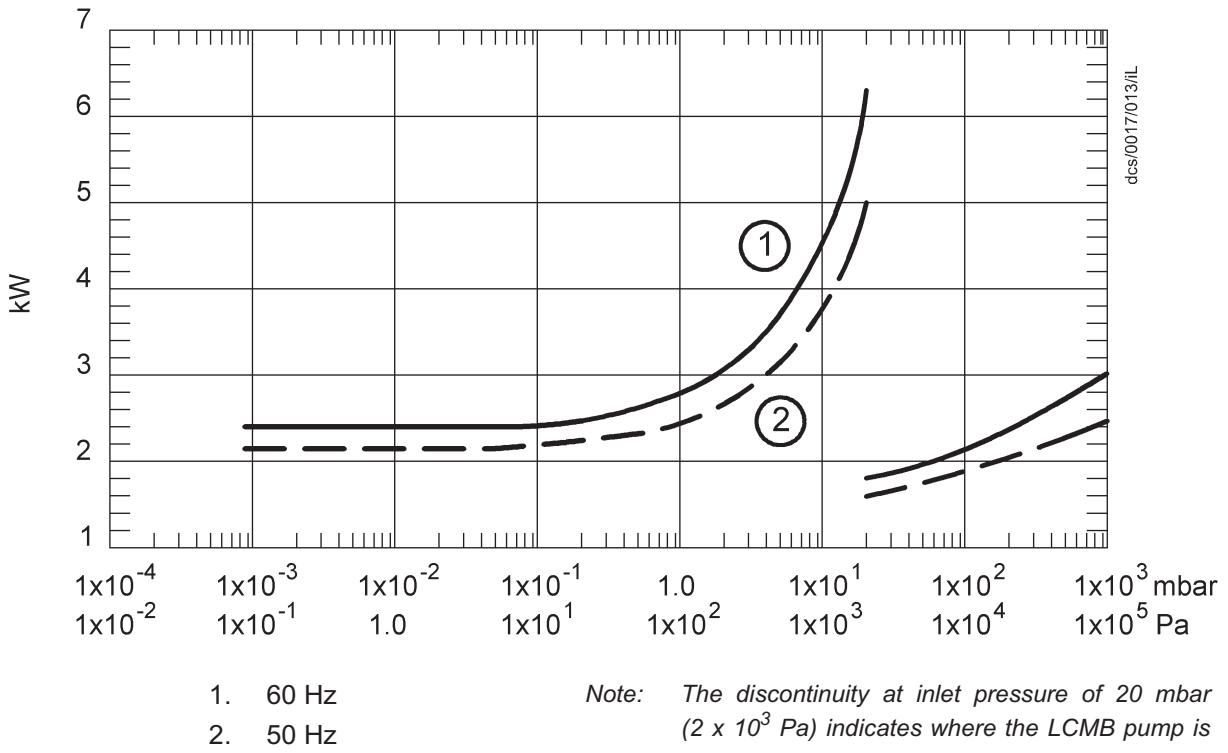

Figure 2-8 - iL600 power curves: electrical power input against inlet pressure

## 2.3 Temperature control system

LCDP shut-down thermal snap-switch	
Opening temperature	60 ± 3 °C
Closing temperature	50 ± 4 °C
Thermocouples	K type class 1
LCMB shut-down thermal snap-switch	
Opening temperature	120 ± 3 °C
Closing temperature	110 ± 4 °C
LCDP and LCMB motor-protection thermistors	
Type	Positive temperature coefficient
Reference temperature	150 °C
Compliant with	IEC 34-11 (BS4999 part III)
Water flow-switch	Closed when flow < 1.5 l.min <sup>-1</sup>

## 2.4 Cooling-water supply

*Note: Use treated water or non-corrosive industrial water to cool the iL system.*

Maximum supply pressure	100 psig (6.9 bar, 6.9 × 10 <sup>5</sup> Pa)
Water supply temperature	10 to 30°C
Typical pressure differential across supply and return *	
iL70	15 psi (1.03 bar, 1.03 × 10 <sup>5</sup> Pa)
iL600	15 psi (1.03 bar, 1.03 × 10 <sup>5</sup> Pa)
Minimum required flow rate for reliable system operation	
iL70	1.5 l.min <sup>-1</sup>
iL600	2.5 l.min <sup>-1</sup>
Typical heat removed from iL system	
iL70	1.2 kW
iL600	1.8 kW
Maximum particle size in supply	0.03 mm <sup>2</sup>
Water supply quality	
Acidity	pH 6.5 to 8.0
Hardness	< 100 p.p.m
Resistivity	> 1 k Ω.cm <sup>-1</sup>
Solids (turbidity)	< 100 p.p.m

\* With cooling-water supply temperature of 20 °C and flow rate of 3 l.min<sup>-1</sup>.

## 2.5 Lubrication

*Note: A BOC Edwards Material Safety Data Sheet for the oil referenced in the following sections is available on request.*

### 2.5.1 LCDP pump

#### Gearbox

Oil charge	0.75 litres (typical)
Grade of oil	SAE 40
ISO viscosity grade	150
Recommended perfluoropolyether oils	Fomblin 25/6, Krytox 1525, Drynert 25/6

### 2.5.2 LCMB pump (iL600 only)

#### Gearbox

Oil charge	0.75 litres (typical)
Grade of oil	SAE 40
ISO viscosity grade	150
Recommended perfluoropolyether oils	Fomblin 25/6, Krytox 1525, Drynert 25/6

## 2.6 Electrical data

#### Electrical supply

Supply voltage	200-208/380-415 V at 50 Hz, 3-phase 200-230/460 V at 60 Hz, 3-phase
Voltage tolerance	10% (except for 208 V and 415 V at 50 Hz, which are +6% and -10%)

#### Full load current ratings

See Table 2-2

#### Fuse types and ratings

F1 *	30 A, 600 V, Class J
F2 *	30 A, 600 V, Class J
F3 *	30 A, 600 V, Class J
F4 *†	20 A, 600 V, Class J
F5 *†	20 A, 600 V, Class J
F6 *†	20 A, 600 V, Class J
F7	1.6 A, 250 V
F8	1.6 A, 250 V
F9	3.15 A, 250 V

#### Emergency stop switch rating

24 V a.c./d.c., 5 A max

#### External emergency stop switch

Rating	24 V a.c., 5 A
Load	700 mA (inductive)

† iL 600 only

\* These fuse ratings are included for information only. You cannot change these fuses; a BOC Edwards service engineer must change these fuses.

Supply voltage and frequency →		200-208 V 50 Hz	200-208 V 60 Hz	230 V 60 Hz	380-415 V 50 Hz	460 V 60 Hz
iL70	Full load (A)	9	9.6	9.0	4.5	4.5
	LCDP motor rating (kW)	1.85	2.2	2.2	1.85	2.2
	Maximum power input to pump motor (kW)	2.5	3.0	3.0	2.5	3.0
iL600	Full load both pump motors(A)	14.2	15.3	14.4	7.1	7.2
	LCMB motor rating (kW)	1.1	1.3	1.3	1.1	1.3
	Maximum power input to both pump motors (kW)	7.09	8.29	8.29	7.09	8.29

Table 2-2 - Full load current ratings

## 2.7 Gas system (sensor-configured iL systems only)

*Note: Once you have connected your nitrogen supply and adjusted the nitrogen supply pressure, for optimum performance of the pressure regulator, we recommend that the stability of your nitrogen supply is such that the supply pressure remains within  $\pm 20$  psi of the adjusted pressure.*

Nitrogen supply pressure range	20 to 100 psig (2.4 to 7.9 bar absolute, $2.4 \times 10^5$ to $7.9 \times 10^5$ Pa)
Typical flow rate	4 slm ( $6.76 \times 10^3$ Pa.ls <sup>-1</sup> )
Pressure transducer accuracy	0.6 psi ( $4.1 \times 10^{-2}$ bar, $4.1 \times 10^3$ Pa) at 6 psig (1.4 bar absolute, $1.4 \times 10^5$ Pa)

## 2.8 Construction materials

### Materials in contact with process gases

#### Gearbox and headplate

Aluminium	Carbon steels EN8DM, EN19T
Grade 250 cast iron	Stainless steels 304, 316 and 316L
LCP (liquid crystal polymer), 30% glass filled	PPS (Polyphenylene sulphide), 40% glass filled
PFPE oil	PTFE (polytetrafluoroethylene)
PBT (polybutylene terephthalate)	PP (polypropylene)
PU (polyurethane)	Viton
Glass	Loctite 648 thread sealant

(Continued on page 2-12)



### Materials in the swept volume

SG iron - 420/12	Grade 250 cast iron
Viton	PFA (perfluoroalkoxy)
Loctite 577 thread sealant	

### Sealing materials

Grade 250 cast iron	Stainless steel 304
Viton	Glass
Silver	Stainless steel 316L
Loctite 577 thread sealant	

### Other materials of construction

Brass water connectors	EN16MT
Copper	Paint

## 2.9 Default setpoints

The default setpoints are shown in Tables 2-3 to 2-5 (see page 2-13). Where there is an 'ADJ' (adjust) entry in these tables, this specifies that the setpoints are usually not used and the default setpoint is preset so that no warning or alarm condition could result from sensor readings. If required you can adjust these 'ADJ' setpoints for your application, so that suitable warnings and alarms can be generated.

## 2.10 Connections

Inlet and outlet	See Table 2-1
Electrical supply connector	
Type	Harting HAN-K-4/2
Cable outside diameter range	18 to 27 mm
Maximum conductor cross-sectional area	16 mm <sup>2</sup>
Pump Display Module connector	XLR type 4-way
Network communications connector	XLR type 4-way
GRC relay connector #	6-pin DIN
iL Tool Interface Module connector	XLR type 6-way
Water inlet connector †	3/8 inch BSP male quick-disconnect
Water outlet connector †	3/8 inch BSP female quick-disconnect
Nitrogen supply connector *	1/4 inch Swagelok compression fitting
Active gauge connector	SCC68 socket

\* Sensor configured systems only.

# Not used on the iL system.

† Connector mating-halves to connect your cooling-water supply and return pipes are supplied with the iL system: refer to Section 3.18.

Parameter	Unit	Default setpoint values			
		Low alarm	Low warning	High warning	High alarm
LCDP power consumption	kW	ADJ	0.0	3.4	3.8
LCMB power consumption *	kW	- #	- #	- #	- #

\* I1600 only.

# LCMB power threshold is 7.3 kW; maximum time in overload is 15 seconds.

Table 2-3 - Electrics and Pump Control Module default setpoints

Parameter	Unit	Default setpoint values			
		Low alarm	Low warning	High warning	High alarm
LCDP pump temperature	°C	ADJ	ADJ	129	159
LCDP motor cooling-water return temperature	°C	ADJ	ADJ	44	ADJ
LCMB pump temperature *	°C	ADJ	ADJ	99	119

\* iL600 only.

Table 2-4 - Sensor Monitoring Module default setpoints  
(sensor-configured iL systems only)

Parameter	Unit	Default setpoint values			
		Low alarm	Low warning	High warning	High alarm
Shaft-seals purge pressure	psig	2.7	3.0	5.0	6.5

Table 2-5 - Gas Module default setpoints  
(sensor-configured iL systems only)

## 2.11 Item Numbers

### 2.11.1 Standard iL systems

Electrical supply	iL70	iL600
460 V, 60 Hz, 3-phase	A533-71-908	A533-72-908
200/208 V, 50/60 Hz, 3-phase	A533-71-945	A533-72-945
380/415 V, 50 Hz, 3-phase	A533-71-946	A533-72-946
230 V, 60 Hz, 3-phase	A533-71-957	A533-72-957

### 2.11.2 Sensor-configured iL systems

Electrical supply	iL70	iL600
460 V, 60 Hz, 3-phase	A533-74-908	A533-75-908
200/208 V, 50/60 Hz, 3-phase	A533-74-945	A533-75-945
380/415 V, 50 Hz, 3-phase	A533-74-946	A533-75-946
230 V, 60 Hz, 3-phase	A533-74-957	A533-75-957

## 3 INSTALLATION

### 3.1 Safety

#### WARNING

Obey the safety instructions given below and take note of appropriate precautions. If you do not, you can cause injury to people and damage to equipment

Ensure that the iL system is suitable for your application: refer to Section 1.2.2.

You must not use the iL system in an application where incompatible gases are pumped, one after the other. If you do, the gases will mix in the gearbox(es).

A suitably trained and supervised technician must install the iL system.

Ensure that the installation technician is familiar with the safety procedures which relate to the products pumped. Wear the appropriate safety-clothing when you come into contact with contaminated components. Dismantle and clean contaminated components and drain oil inside a fume-cupboard.

If the iL system is to replace an existing pumping system, vent and purge the process system with nitrogen for 15 minutes before you start installation work; if the existing pumping system is an iL system, use the procedure in Section 6.1.2.

Disconnect the other components in the process system from the electrical supply so that they cannot be operated accidentally.

Do not reuse any 'O' ring or 'O' ring assembly and do not allow any debris to get into the iH system during installation.

Consult BOC Edwards publication P300-20-000 (Vacuum Pump and Vacuum System Safety) before you pump hazardous materials. This publication is available on request: contact your supplier or BOC Edwards.

### 3.2 Installation checklist

The operations required to install the iL system and the sections of this instruction manual which describe those operations are shown in Table 3-1.

<b>Installation operation</b>	<b>Section</b>
Unpack and inspect	3.3
Remove the enclosure panels	3.4
Reconfigure the nitrogen and cooling-water connections (if required)	3.5
Locate the iL system	3.6
Check the pump oil-level(s)	3.7
iL70 systems	3.7.1
iL600 systems	3.7.2
Install or replace the Pump Display Module and optional accessories (if necessary)	3.8
Install the Pump Display Module (optional)	3.8.1
Install other optional accessories	3.8.2
Connect the iL inlet to your vacuum system	3.9
Connect the iL exhaust outlet to your exhaust extraction system	3.10
Connect to your factory extraction system (optional)	3.11
Connect the nitrogen supply (sensor-configured iL systems only)	3.12
Leak test the system	3.13
Install additional safety equipment (optional)	3.14
Connect to your emergency stop circuit (optional)	3.15
Electrical supply and RF earth (ground) connections	3.16
Reconfigure the iL system for your electrical supply (if necessary)	3.16.1
Reconfigure the pump(s) for your electrical supply (if necessary)	3.16.2
Connect the electrical supply	3.16.3
Connect an additional RF earth (optional)	3.16.4
Refit the enclosure panels	3.17
Connect the cooling-water pipelines	3.18
Commission the iL system	3.19
Switch on an iL70 system	3.19.1
Configure and switch on an iL600 system	3.19.2

Table 3-1 - Installation checklist

### 3.3 Unpack and inspect

#### WARNING

You must use suitable lifting equipment to move the iL system. It is too heavy to lift by hand.

#### WARNING

Ensure that the maximum angle between paired slings used to lift the iL system is 60°.

The iL system is supplied sealed in a foil bag. To prevent contamination of the iL system, before you unpack and inspect the iL system we recommend that you move the pallet as close as possible to the clean area in which you will install the system. Remove the foil bag carefully; use the bag as a dust cover while you wheel the iL system to its final operating position.

Use the following procedure to unpack and inspect the iL system.

1. Place the pallet in a convenient position with a fork-lift truck or a pallet truck.
2. Remove the staples which secure the cardboard box to the pallet, then remove the cardboard box. Open the top of the foil bag which encloses the iL system.
3. If you have an iL600 system, remove the four screws which secure the wooden stabiliser to the LCMB pump-inlet, remove the stabiliser, then refit the four screws to the LCMB pump-inlet blanking plate. Retain the stabiliser for future use.
4. Refer to Figure 3-1. Remove the nut and washer (2) which secures each of the four brackets (5) to the blocks (4) on the pallet. Retain the nuts and washers for future use.
5. Refer to Figure 3-3. Use a flat-bladed screwdriver to undo the two quarter-turn catches (2) on the end of the top cover (1), pull the cover back (towards the outlet), then remove the top cover from the iL system.
6. Refer to Figure 3-2. If you have an iL600 system, remove the three lifting-bolts from the lifting-bolt holder (2), then fit the lifting-bolts (1) to the top of the LCMB pump in the positions shown in detail B.
7. Refer to Figure 3-2 detail A or B. Use suitable lifting-equipment attached to the lifting bolts (1) to remove the iL system from its pallet. Do not try to lift the iL system by hand (see Section 2 for the mass of the iL system).
8. Inspect the iL system. If the iL system or any other item is damaged, notify your supplier and the carrier in writing within three days; state the Item Number of the iL system together with your order number and your supplier's invoice number. Retain all packing materials for inspection. Do not use the iL system if it is damaged.
9. Check that the pallet contains the items listed in Table 3-2. If any of these items is missing, notify your supplier in writing within three days.

(Continued on page 3-4)

10. If the iL system is not to be used immediately, replace the packing materials. Store the iL system in suitable conditions as described in Section 7. If you will use the iL system immediately, continue at Step 11.
11. Refer to Figure 3-1. If you do not want to fit restraints to prevent inadvertent movement of the iL system (see Section 3.6), undo and remove the two nuts and washers (6) which secure each of the four brackets (5) to the sides of the iL system, then remove the brackets. Retain the brackets, nuts and washers for future use.

Qty	Description	Check (✓)
1	iL dry pumping system	<input type="checkbox"/>
Fitting-kit which contains the following:		
1	Inlet 'O' ring †	<input type="checkbox"/>
1	Cooling-water quick-release connectors (pair)	<input type="checkbox"/>
1	NW40 trapped 'O' ring	<input type="checkbox"/>
1	NW40 clamp	<input type="checkbox"/>
1	Module connector terminator plug	<input type="checkbox"/>
1	Emergency stop switch guard *	<input type="checkbox"/>
1	Electrical supply connector	<input type="checkbox"/>

\* If required, fit this over the emergency stop switch to prevent inadvertent operation of the switch.

† iL70 only.

Table 3-2 - Checklist of components

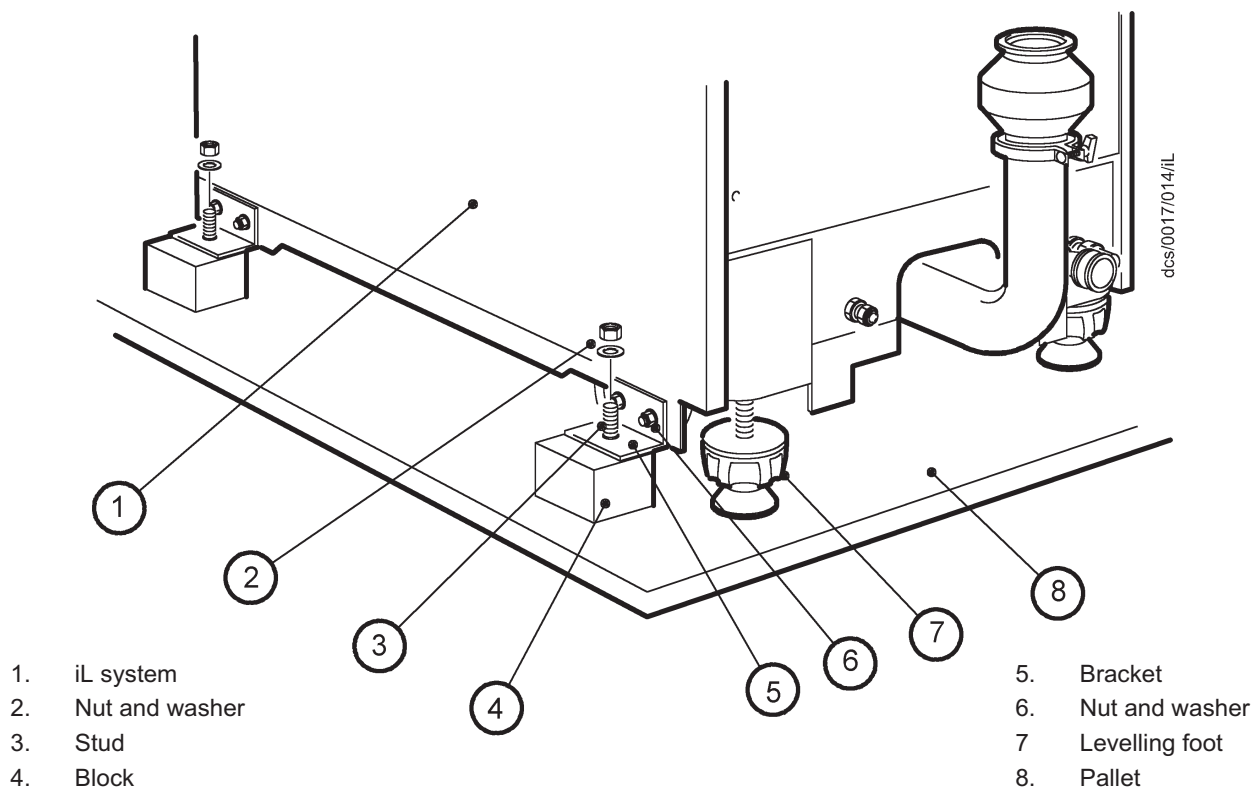
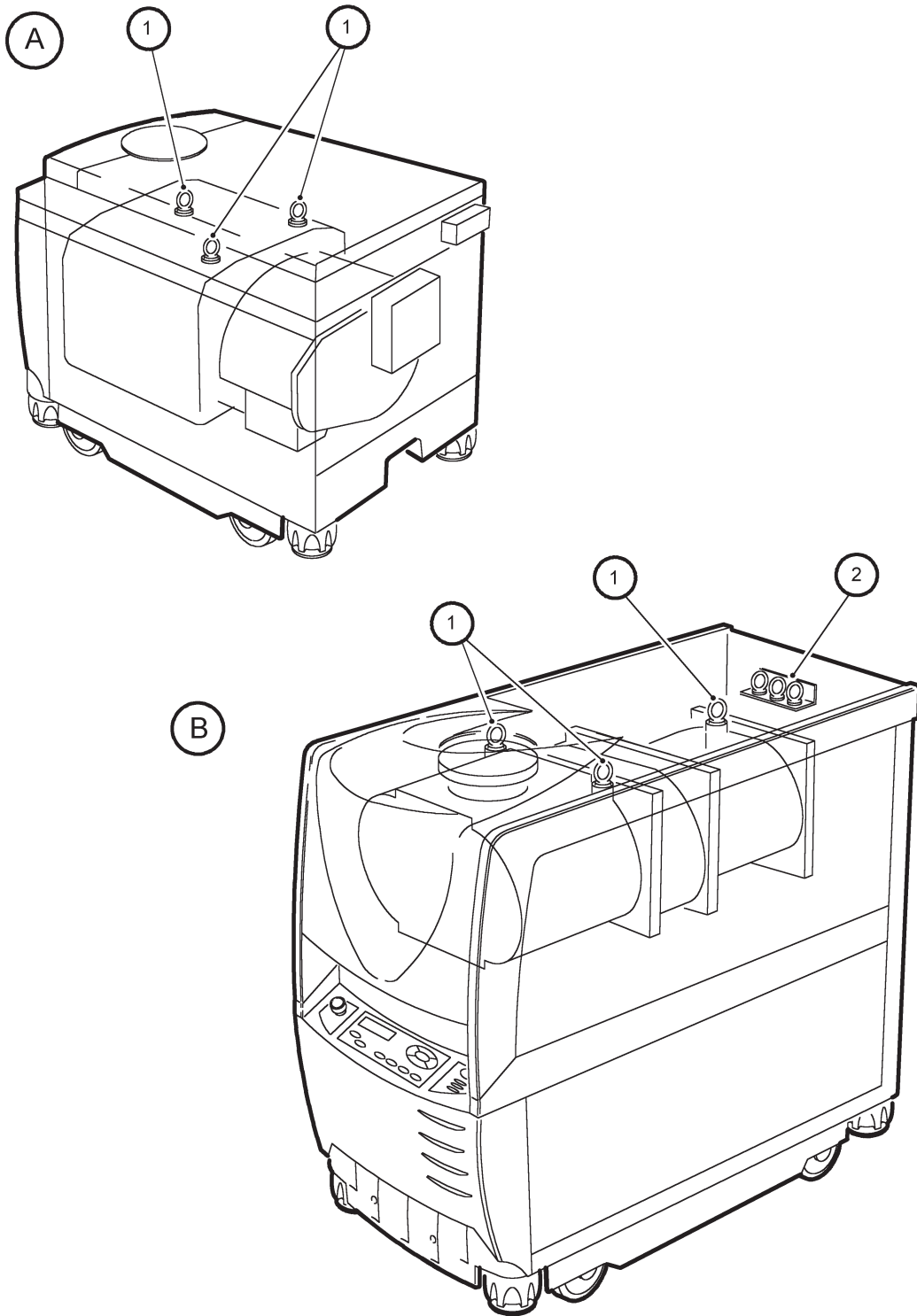

Figure 3-1 - Remove the iL system from the pallet

dcsl0105/01



- A iL70
- B iL600

- 1. Lifting-bolts
- 2. Lifting-bolt holder

Figure 3-2 - Lifting-bolt positions



### 3.4 Remove the enclosure panels

1. Refer to Figure 3-3. If you have an iL 600 system, continue at Step 2, otherwise continue at Step 4.
2. Refer to detail A. Remove the LCMB right-hand side panel from the iL system:

Place your hand against the top of the right-hand side panel (4) to support it and use a flat-head screwdriver to release the two quarter-turn catches (3).

Swing the top of the panel out slightly and lift out the panel so that the slots in the bottom of the panel disengage from the locating plates on the frame (5).

Fully remove the panel and place it in a safe location.
3. Remove the LCMB left-hand side panel: use the method in Step 2 above.
4. Refer to detail B. Remove the LCDP right-hand and left-hand side panels: use the method in Step 2 above.

### 3.5 Reconfigure the nitrogen and cooling-water connections (if required)

Refer to Figure 2-3, detail A. As supplied, the cooling-water connections (1, 2) and (on sensor-configured iL systems only) the nitrogen inlet (3) are at the rear of the iL system, as shown in detail A. If required, you can reconfigure the iL system so that the cooling-water connections (4, 5) and/or the nitrogen inlet (6) are at the front of the iL system, as shown in detail B.

You will need an Alternative Nitrogen Connection Kit (see Section 8.4.10) if you want to reconfigure the nitrogen connection. Reconfigure the nitrogen connection as described in the instruction manual supplied with the kit.

If required, use the following procedure to reconfigure the cooling-water connections:

1. Refer to Figure 3-3, detail A. Undo and remove the two screws (6) and remove the lower cover (7).
2. Refer to Figure 3-4. Disconnect the female connector on the end of the water supply hose (3) from the cooling-water inlet (5).
3. Disconnect the female connector on the end of the water return hose (2) from the cooling-water outlet (6).
4. Undo and remove the locknuts which secure the cooling-water inlet and outlet quick-release connectors (5, 6) to the rear bulkhead (4) and remove the connectors.
5. Refer to detail B. Fit the cooling-water inlet and outlet quick-release connectors (5, 6) to their alternative positions on the front bulkhead (7), then fit the locknuts (removed in Step 4) to secure the connectors in place.
6. Apply a suitable thread sealant (such as Loctite 577) to the threads of the male connector on the rear of the cooling-water inlet quick-release connector (5), then fit the female connector on the end of the water supply hose (3) to the connector.

(Continued on page 3-8)

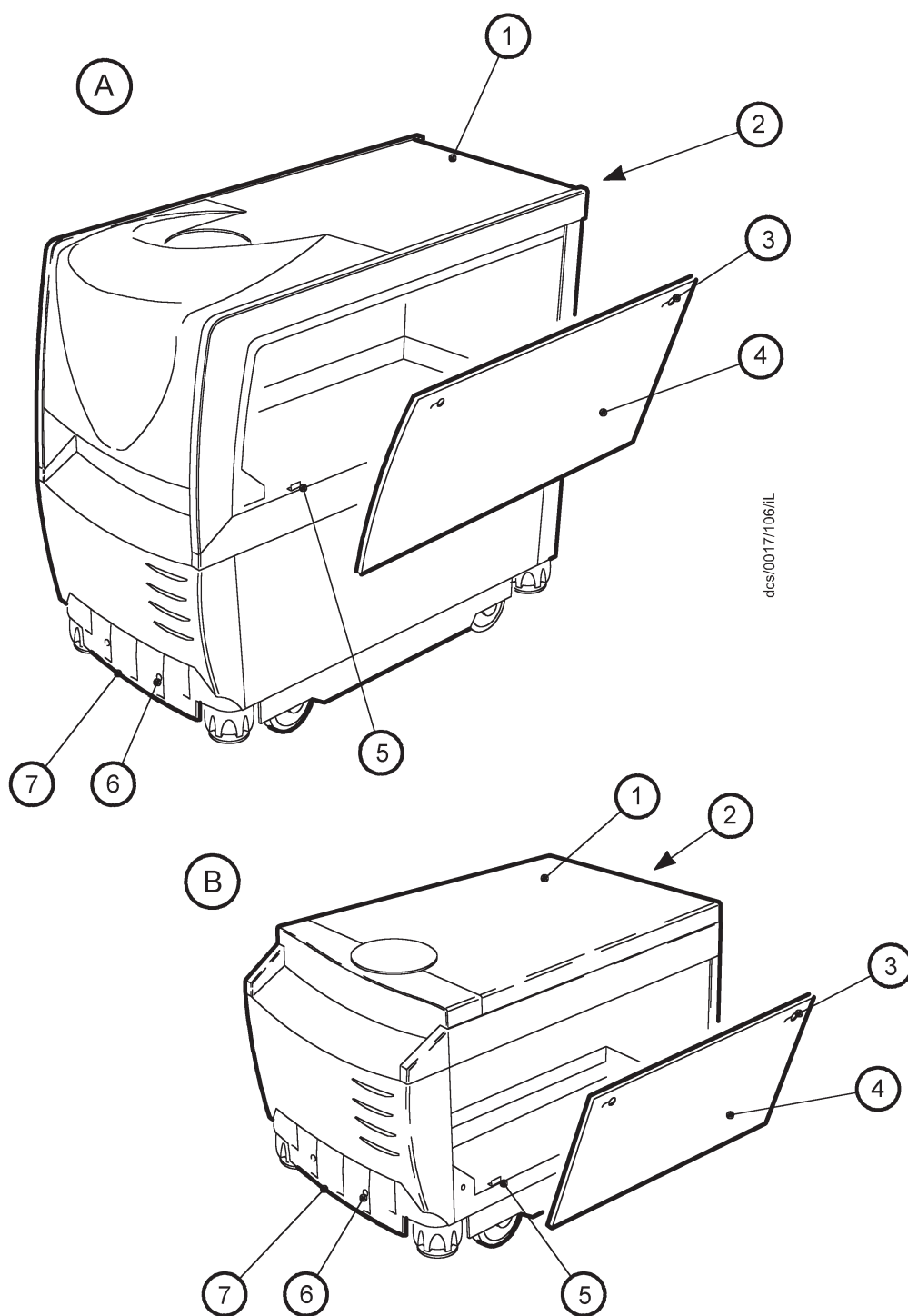

A iL600

B iL70

1. Top panel

2. Catches (on rear of item 1)

3. Catches

4. Right-hand side panel

5. Locating plates

6. Screws (2 off)

7. Lower cover

Figure 3-3 - Remove/refit the enclosure panels

7. Apply a suitable thread sealant (such as Loctite 577) to the threads of the male connector on the rear of the cooling-water outlet quick-release connector (6), then fit the female connector on the end of the water return hose (2) to the connector.
8. Connect a suitable blanked pipe with a pressure gauge to the cooling-water outlet connector (6), and connect a pressurised water supply to the cooling-water inlet connector (5).
9. Pressurise the cooling-water system to a pressure of 7 bar ( $7 \times 10^5$  Pa), then check for water leaks:
  - If there are water leaks, drain the water, seal any leaks found, then repeat this step (Step 9) again.
  - If there are no water leaks, continue at Step 10.
10. Leave the system pressurised for approximately five minutes, then check the pressure shown on the pressure gauge:
  - If the pressure has fallen by less than 0.1 bar ( $1 \times 10^4$  Pa), continue at Step 11.
  - If the pressure has fallen by more than 0.1 bar ( $1 \times 10^4$  Pa), contact your supplier or BOC Edwards for advice.
11. Reduce the pressure in the cooling-water system to  $4.5 \pm 0.5$  bar ( $4.5 \times 10^5 \pm 5 \times 10^4$  Pa), then check for water leaks:
  - If there are water leaks, drain the water, seal any leaks found, then repeat this procedure from Step 9 again.
  - If there are no water leaks, continue at Step 12.
12. Leave the system pressurised for two minutes, then check the pressure shown on the pressure gauge:
  - If the pressure has fallen by less than 0.1 bar ( $1 \times 10^4$  Pa), continue at Step 13.
  - If the pressure has fallen by more than 0.1 bar ( $1 \times 10^4$  Pa), contact your supplier or Edwards for advice.
13. Drain the water from the iL system and disconnect the blanked pipe and pressure gauge and the pressurised water supply from the cooling-water inlet and outlet connectors (5, 6).

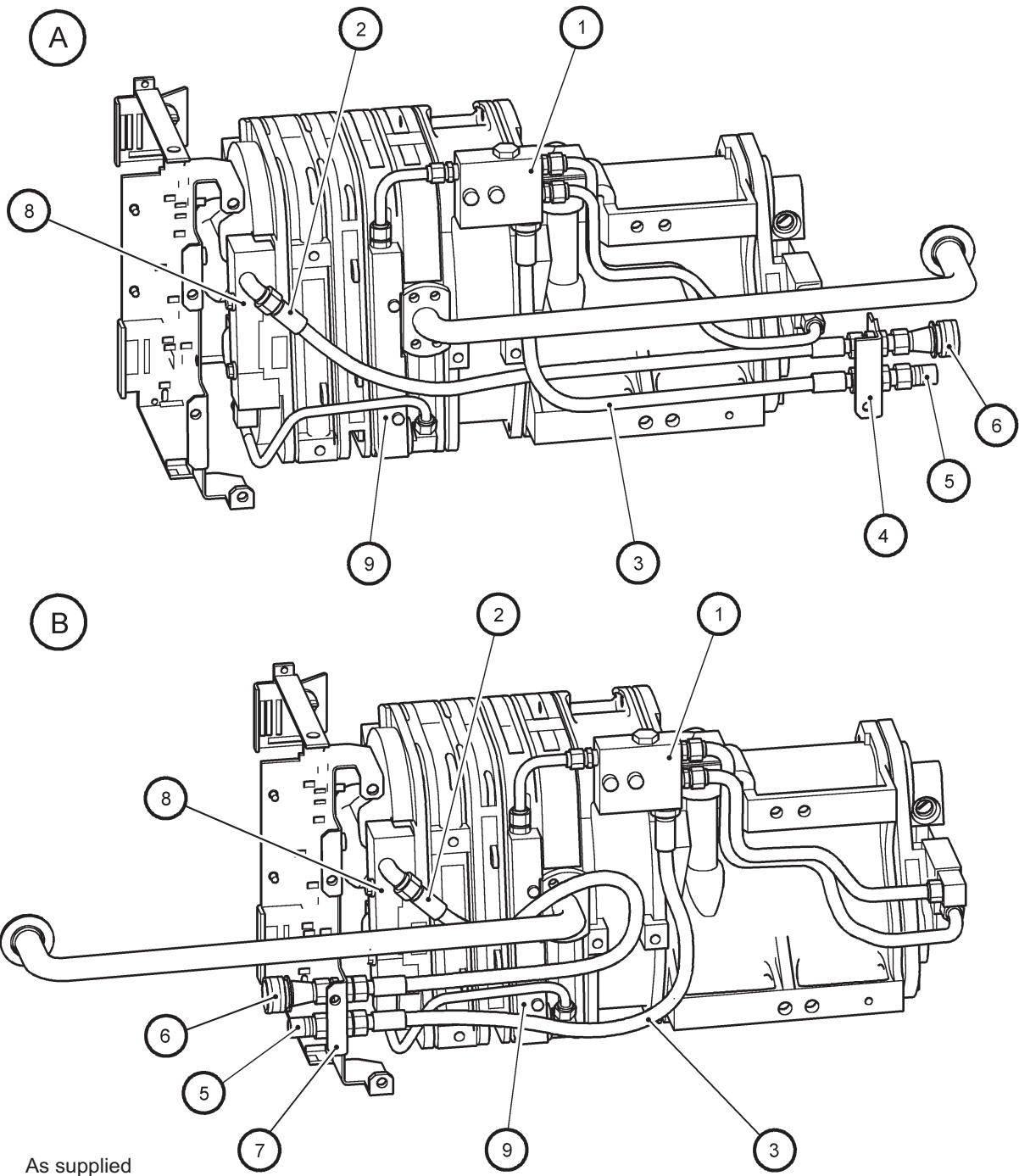

dcs/0105/02

- A As supplied
- B Alternative configuration

- |                      |   |
|----------------------|---|
| 1. Water manifold    | 5. Cooling-water inlet (quick-release connector)  |
| 2. Water return hose | 6. Cooling-water outlet (quick-release connector) |
| 3. Water supply hose | 7. Front bulkhead                                 |
| 4. Rear bulkhead     | 8. HV water manifold                              |
|                      | 9. 4th Stage water manifold                       |

Figure 3-4 - Reconfigure the cooling-water connections (if required)

### 3.6 Locate the iL system

#### WARNING

You must use suitable lifting equipment to move the iL system. It is too heavy to lift by hand.

#### WARNING

Ensure that the maximum angle between paired slings used to lift the iL system is 60°.

Use the following procedure to locate the iL system in its operating position. The iL system must be located on a firm, level surface.

1. Use suitable lifting equipment attached to the lifting bolts (Figure 3-2, items 1) to move the iL system close to its final operating position.
2. Refer to Figure 3-5. Remove the nuts and washers (4) which secure the four transit brackets (2) to the vibration isolators (3), then remove the transit brackets.
3. Wheel the iL system on its castors to move it into its operating position.
4. Adjust the levelling feet to make sure that the iL system is level and is not supported by the castors.
5. If required, fit restraints to prevent inadvertent movement of the iL system; you can attach these restraints to the brackets fitted to the sides of the iL system.

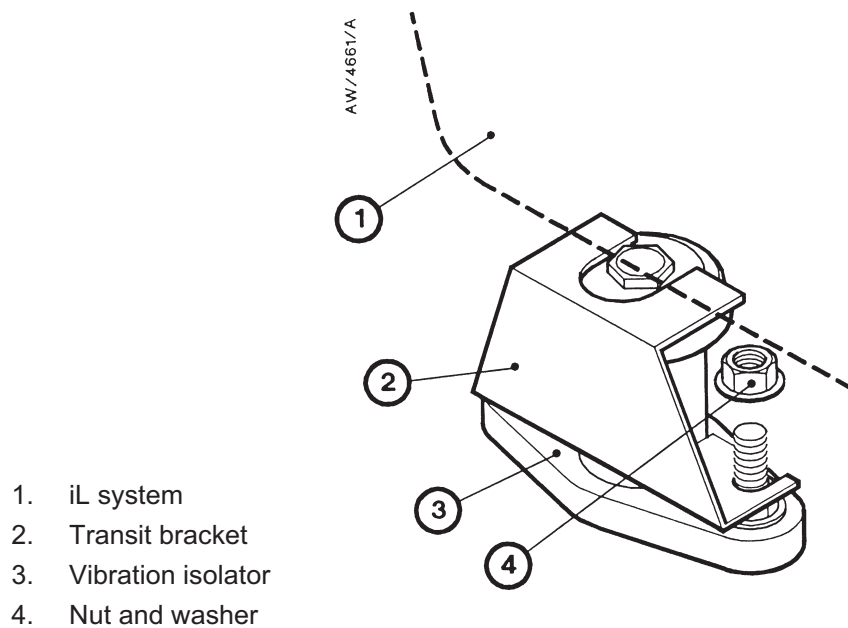

Figure 3-5 - Remove the vibration isolator transit brackets

## 3.7 Check the pump oil-levels

### CAUTION

Ensure that the oil-levels in the LCDP pump and the LCMB pump (in an iL600 system) are correct. If a pump oil-level is incorrect, pump performance may be affected and the pump may be damaged.

### 3.7.1 iL70 systems

The iL70 system is supplied with the LCDP pump filled with oil. However, we recommend that you check the oil-level before you operate the iL system; use the method described below.

Refer to Figure 1-1. Check the oil-level against the MAX mark (see detail B) on the bezel of the LCDP oil-level sight-glass (10):

If the oil-level is above the MAX mark, drain excess oil from the pump as described in Section 6.8 until the oil-level is correct.

If the oil-level is below the MAX mark, fill the pump with oil until the oil-level is correct, as described in Section 6.8.

### 3.7.2 iL600 systems

The iL600 system is supplied with both the LCDP and LCMB pumps filled with oil. We recommend that you check the LCDP and LCMB oil-levels as described below.

1. Check the LCDP pump oil-level: refer to Section 3.7.1.
2. Refer to Figure 1-1. Check the oil-level against the MAX mark (see detail B) on the bezel of the LCMB oil-level sight-glass (4):

If the oil-level is above the MAX mark, drain excess oil from the pump as described in Section 6.9 until the oil-level is correct.

If the oil-level is below the MAX mark, fill the pump with oil until the oil-level is correct, as described in Section 6.9.

## 3.8 Install or replace the Pump Display Module and other optional accessories (if necessary)

### 3.8.1 Install the Pump Display Module (optional)

1. Unpack and inspect the Pump Display Module.
2. Refer to Figure 3-6. Remove the blanking panel (1) from the front panel (2).
3. Fit the connector (4) on the end of the cable (6) to the module connector (3) in the recess (5) in the front panel.

(Continued on Page 3-12)

4. Place the coiled cable (6) in the recess, then place the Pump Display Module (7) in position in the recess (5).

### 3.8.2 Install other optional accessories

*Note: Some accessories can only be factory fitted (see section 8): you will have ordered these accessories when you ordered your iL system, and the accessories will be supplied fitted to your iL system.*

Install optional accessories (listed in Section 8.4) as described in the instructions supplied with the accessory.

### 3.9 Connect the iL inlet to your vacuum system

*Note: If required (that is, if you want to use the iL system in an area subject to high RF (radio frequency) emissions), connect the end of the iL earth (ground) cable to one of the bolts that you use to connect the inlet-flange of the iL system to your process system. See Section 3.16.4 for more information.*

When you connect your iL system to your vacuum system, take note of the following:

To get the best pumping speed, ensure that the pipeline which connects the vacuum system to the iL system is the minimum length possible and has an internal diameter not less than the iL system inlet-port.

Ensure that all components in the vacuum pipeline have a maximum pressure rating which is greater than the highest pressure that can be generated in your system.

Incorporate flexible pipelines in the vacuum pipeline to reduce the transmission of vibration and to prevent loading of coupling-joints. We recommend that you use BOC Edwards flexible pipelines.

Adequately support vacuum pipelines to prevent the transmission of stress to pipeline coupling-joints.

Incorporate a pressure gauge in the inlet pipeline, so that you can determine that the iL system operates correctly and (on iL600 systems) so that you can determine the correct booster start delay (see Section 3.19.2). On sensor-configured iL systems, you can fit an Active Gauge Connection Kit accessory (see Section 8.4.4) or an iL600 Pressure Control Kit accessory (see Section 8.4.8) for this purpose.

You must be able to isolate the iL system inlet from the atmosphere and from your vacuum system if you have pumped or produced hazardous, corrosive or toxic chemicals.

Use the following procedure to connect the inlet of the iL system to your vacuum inlet pipeline:

1. If fitted, remove the blanking plate from the inlet of the iL system. Retain the nuts, bolts and washers which secured the blanking plate for future use.
2. Use the 'O' ring supplied (iL70 systems only) and the nuts, bolts and washers (removed in Step 1) to connect the inlet-flange of the iL system to your vacuum system.

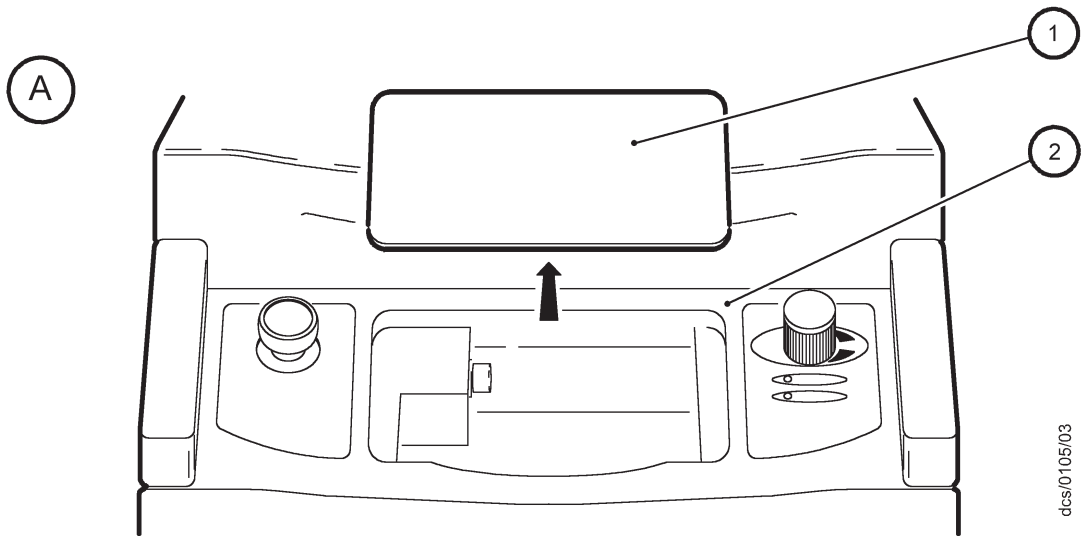

dcsl/01/05/03

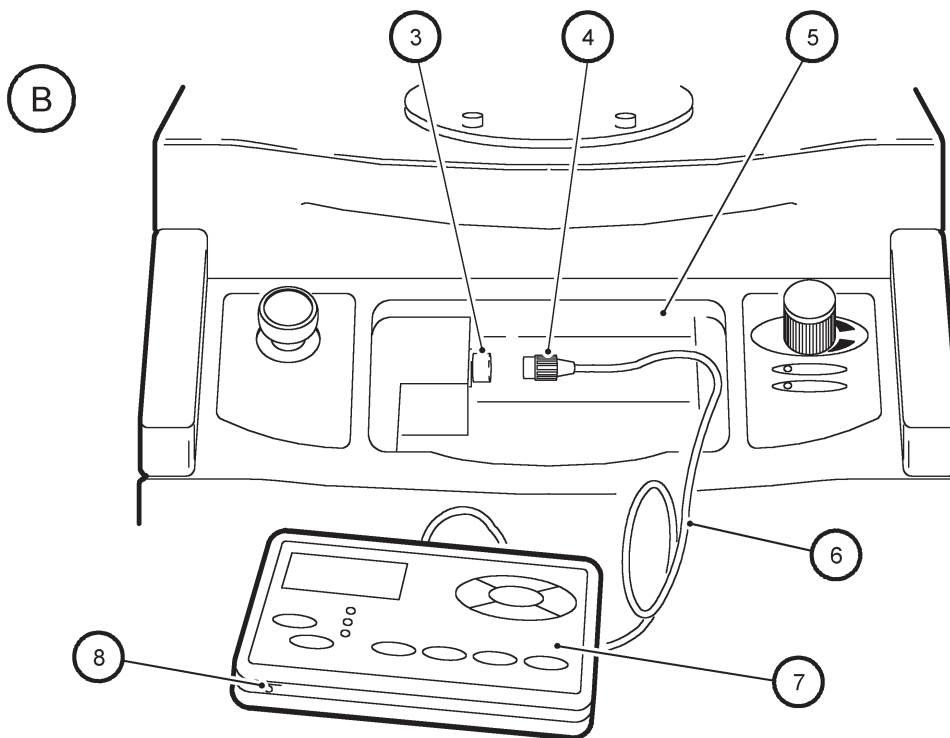

- A Remove the blanking panel  
 B Fit the Pump Display Module

1. Blanking panel
2. Front panel
3. Connector
4. Connector

5. Recess
6. Cable
7. Pump Display Module
8. Viewing angle adjuster

Figure 3-6 - Fit the Pump Display Module (optional accessory)



### 3.10 Connect the iL exhaust outlet to your exhaust-extraction system

#### WARNING

Pipe the exhaust to a suitable treatment plant to prevent the discharge of dangerous gases or vapours to the surrounding atmosphere.

#### WARNING

Do not operate the iL system with the exhaust pipeline blocked. If the exhaust pipeline is blocked, the iL system can generate exhaust pipeline pressures up to 4 bar ( $4 \times 10^5$  Pa).

#### CAUTION

Use a catchpot to prevent the drainage of condensate back into the iL system. Condensate which drains back into the iL system could damage the LCDP pump.

When you connect to your exhaust-extraction system, take note of the following:

Ensure that all components in the exhaust pipeline have a maximum pressure rating which is greater than the highest pressure that can be generated in your system.

Incorporate flexible pipelines in the exhaust pipeline to reduce the transmission of vibration and to prevent loading of coupling-joints. We recommend that you use BOC Edwards braided flexible pipelines.

You must be able to isolate the exhaust-outlet from the atmosphere if you have pumped or produced hazardous, corrosive or toxic chemicals.

Adequately support exhaust pipelines to prevent the transmission of stress to pipeline coupling-joints.

Use the following procedure to connect the iL exhaust outlet to your exhaust-extraction system:

Refer to Figure 1-1. Use the NW40 trapped 'O' ring and clamp supplied to connect the outlet of the check-valve (17) or the flange on the end of the exhaust-pipe (18) to your exhaust-extraction system.

### 3.11 Connect to your factory extraction system (optional)

As supplied, the temperature control system fitted is sufficient to maintain the iL system at the correct operating temperature; you do not need to connect an air-extraction system to the iL system. However, if required you can connect your factory extraction system to the air-extraction port on the top of the iL system (see Figures 2-1 and 2-2). Note that the iL system is supplied with a finger guard fitted over this port.

### 3.12 Connect the nitrogen supply (sensor-configured iL systems only)

#### CAUTION

Ensure that your nitrogen supply conforms to the requirements given in Section 2. If it does not, the flow sensors may not operate correctly, the gas pipeline may become blocked or the iL system may be damaged.

Connect your nitrogen supply to the iL system through the nitrogen inlet on the rear of the iL system (Figure 1-4, item 4).

Use rigid metal supply pipelines (such as stainless steel). We recommend that the nitrogen supply pipeline to the iL system has an outside diameter of  $\frac{1}{4}$  inch, and that the pipeline is designed and constructed so that large pressure drops are not introduced into the nitrogen supply.

Connect your nitrogen supply pipeline to the Swagelok connector on the nitrogen inlet on the iL system: use the Swagelok connector as described in Section 6.2.

### 3.13 Leak test the system

#### WARNING

Leak-test the system after installation and seal any leaks found to prevent leakage of dangerous substances out of the system and leakage of air into the system.

*Note: If you need further information on leak testing, contact your supplier or BOC Edwards for advice.*

Leak-test the system after installation and seal any leaks found. Dangerous substances which leak from the system will be dangerous to people and there may be a danger of explosion if air leaks into the system.

The pump gearbox(es) are not isolated from the swept volume; you must therefore ensure that the oil filler-plugs are fitted when you leak test the system, to ensure the leak-tightness of the plugs.

Use a pump down test with helium to leak test the system. We recommend that the leak rate is  $1 \times 10^{-5}$  mbar.l.s<sup>-1</sup> ( $1 \times 10^{-3}$  Pa.l.s<sup>-1</sup>) or less for the complete system, or  $1 \times 10^{-6}$  mbar.l.s<sup>-1</sup> ( $1 \times 10^{-4}$  Pa.l.s<sup>-1</sup>) or less for any individual leak.

The iL system is supplied with a blanked leak-test port, as shown in Figure 3-7. To connect to this port:

1. Refer to Figure 3-7. Remove the  $\frac{3}{8}$  inch BSP blanking plug from the port (2 or 5).
2. Fit a suitable NW25 Klein adaptor and 'O' ring and (if required) an elbow to the port, then connect your leak test equipment to the adaptor or elbow.

### 3.14 Install additional safety equipment (optional)

## WARNING

If your Process Tool/control system needs to know the total flow rate of nitrogen to the iL system for safety reasons, install suitable measurement equipment in the nitrogen supply pipeline.

On a sensor-configured iL system, if you need to know the total flow rate of nitrogen to the LCDP pump for safety reasons, you should fit suitable measurement equipment in the nitrogen supply pipeline. If you fit a rotameter, ensure that it is suitable for use with nitrogen and that it is correctly calibrated.

If the nitrogen supply to the iL system fails, a warning message will be shown on the Pump Display Module (if fitted) and will be sent to the Interface Module(s) connected to the iL system. Ensure that your installation is configured so that it remains safe if there is a failure of the nitrogen supply to the iL system.

If an alarm condition is detected (and the iL system is not configured to 'run til crash': see Section 5.9) the iL system will shut down automatically. You must ensure that your installation remains safe if the iL system shuts down automatically.

### 3.15 Connect to your emergency stop circuit (optional)

*Note: If you do not connect to your own control equipment, you must fit the iL Tool Interface Module plug supplied to the iL Tool Interface Module connector on the rear of the iL system (Figure 1-4, item 8). If you do not, you will not be able to operate the iL system.*

If required, you can connect your own control equipment to the iL system to shut down the iL system in an emergency. Use the following procedure

1. Remove the link between pins 1 and 2 of the iL Tool Interface Module plug supplied.
2. Connect a suitable cable to the plug; Table 3-3 shows the use of the pins in the plug.
3. Refer to Figure 1-4. Fit the plug to the iL Tool Interface Module connector (8) on the rear of the iL system.

Pin(s)	Use
1 and 2	Linked as supplied. Remove the link and connect these pins to your normally-closed, isolated external emergency stop circuit.
3 and 4	Isolated auxiliary contacts of the emergency stop switch on the Electrics and Pump Control Module.
5	24 V a.c. continuous output; maximum current 625 mA
6	0 V return

Table 3-3 - Pins in the iL Tool Interface Module plug

### 3.16 Electrical supply and RF earth (ground) connections

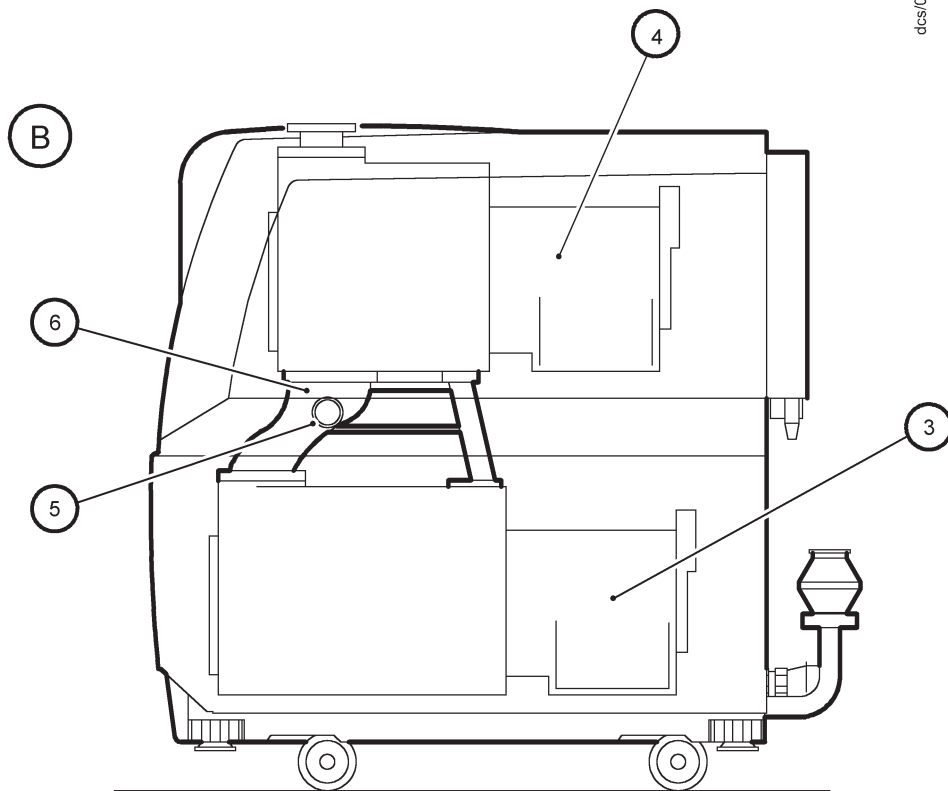
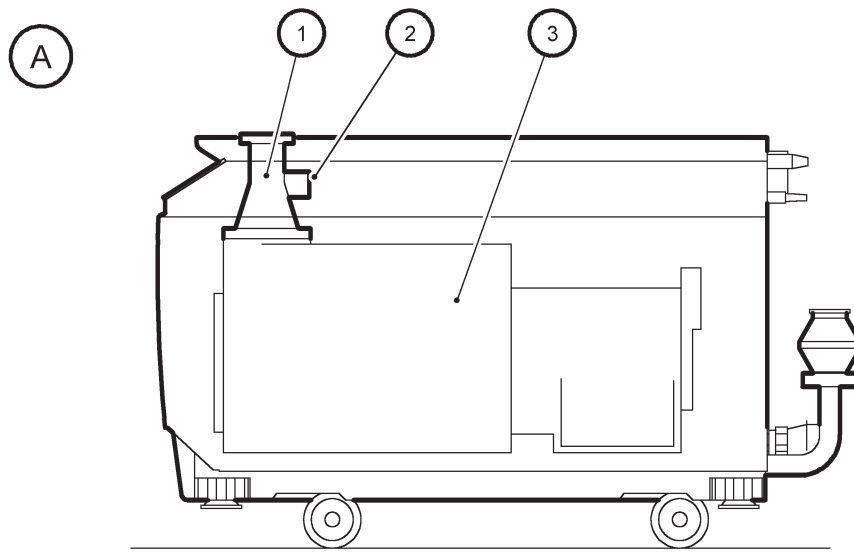

dcs/0017/019/iL

- |                              |  |   |
|------------------------------|--|---|
| <p>A iL70</p> <p>B iL600</p> | <p>1. Inlet spool piece</p> <p>2. Leak-test port (blanked)</p> <p>3. LCDP pump</p> | <p>4. LCMB pump</p> <p>5. Leak-test port (blanked)</p> <p>6. Support manifold</p> |
|------------------------------|--|---|

Figure 3-7 - Leak-test port position

### 3.16.1 Reconfigure the iL system for your electrical supply (if necessary)

Your iL system will be supplied correctly configured for your electrical supply; the Item Number of the iL system (shown on the rating plate: Figure 3-9, item 1) specifies how the system is configured: refer to Section 2.11.

If you want to use the iL system with a different electrical supply, ensure that the correct transformer primary tapping is selected before you connect the electrical supply to the iL system: refer to Figure 3-8 and use the following procedure:

1. Undo the screws (5) which secure the cover (4) to the Electrics Module (2) and remove the cover.
2. Ensure that the common cable (6) is correctly connected to the common terminal on the terminal-block (8).
3. Ensure that the voltage select cable (7) is connected to the correct voltage terminal of the terminal-block (8) for your electrical supply.
4. Refit the cover (4) and secure with the two screws (5).

### 3.16.2 Reconfigure the pump(s) for your electrical supply (if necessary)

Your iL system will be supplied correctly configured for your electrical supply; the Item Number of the iL system (shown on the rating plate: Figure 3-9, item 1) specifies how the system is configured: refer to Section 2.11.

If you want to use the iL system with a different electrical supply, use the following procedure to check and reconfigure the pump(s):

1. Refer to Figure 3-9 detail A. Undo and remove the six screws (5) which secure the blanking plate (4) over the LCDP pump-motor, and remove the blanking plate.
2. Undo and remove the four screws (3) which secure the cover (2) to the LCDP pump-motor terminal-box.
3. Look at the links in the terminal-box (8):
  - For high voltage operation (380-415 V at 50 Hz or 460 V at 60 Hz), ensure that the links (9) are in the positions shown in detail C.
  - For low voltage operation (200-208 V at 50 Hz or 200-230 V at 60 Hz), ensure that the links (9) are in the positions shown in detail D.
4. Refer to detail A. Refit the cover (2) to the LCDP pump-motor terminal-box and secure with the four screws (3).
5. Refit the blanking plate (4) and secure with the six screws (5).
6. Remove the rating label (1) from the Electrics Module. (This label now shows the incorrect electrical supply information for the reconfigured pump.)
7. If you have an iL600, continue at Step 8, otherwise continue at Section 3.16.3.
8. Refer to detail B. Undo and remove the four screws (7) which secure the Electrics and Pump  
(Continued on page 3-20)

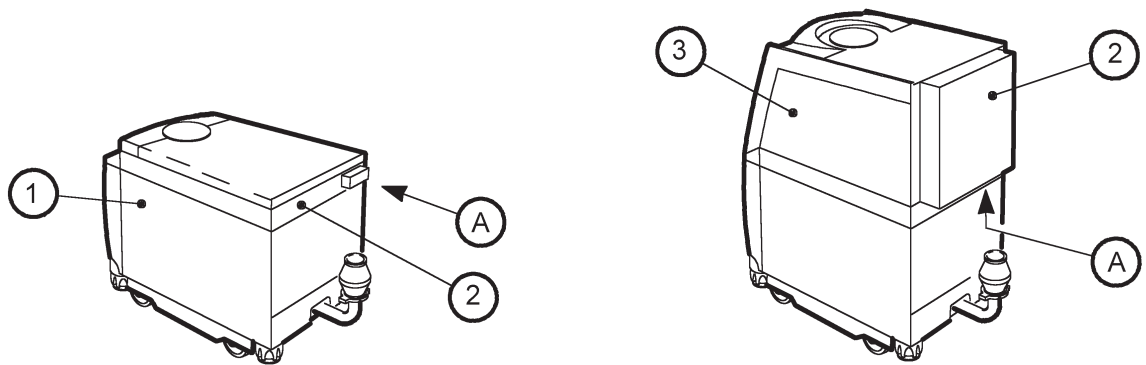

dcs/0017/020/iL

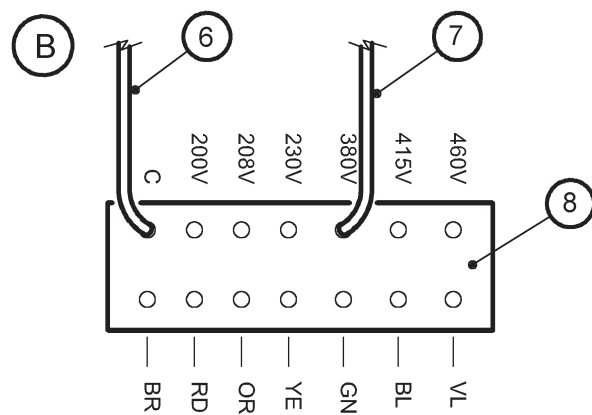
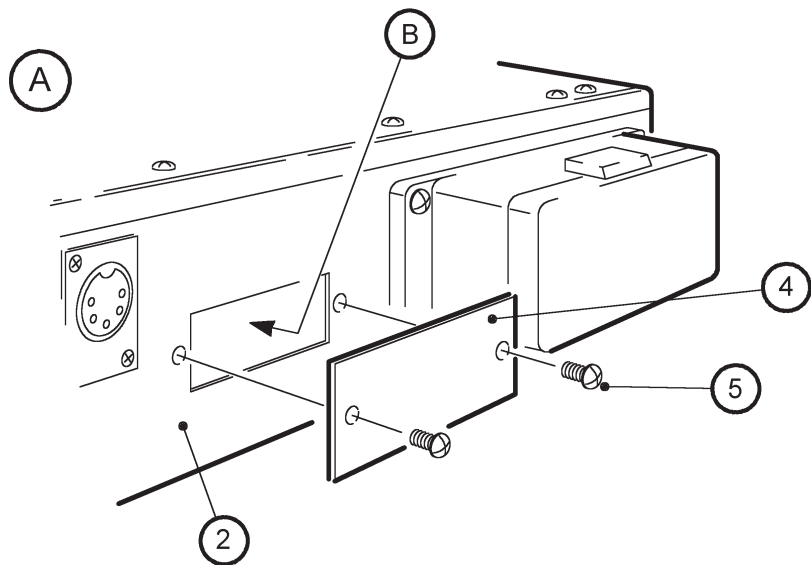

1. iL70 system
2. Electrics and Pump Control Module
3. iL600 system
4. Cover
5. Screw
6. Common cable
7. Voltage select cable
8. Terminal-block

Figure 3-8 - Reconfigure the iL system for your electrical supply (if necessary)

Control Module (6) to the rear of the iL system, then carefully lower and support the Module. Ensure that you do not disconnect, break or damage any of the cables connected to the Module.

9. Undo and remove the four screws (3) which secure the cover (2) to the LCMB pump-motor terminal-box, then remove the cover (through the access hole in the rear cover-plate).
10. Look at the links in the terminal-box (8):
  - For high voltage operation (380-415 V at 50 Hz or 460 V at 60 Hz), ensure that the links (9) are in the positions shown in detail C.
  - For low voltage operation (200-208 V at 50 Hz or 200-230 V at 60 Hz), ensure that the links (9) are in the positions shown in detail D.

If you reconfigure the links, ensure that wires fitted to different terminals in the terminal-box do not touch each other.
11. Refit the cover (2) to the pump-motor terminal-box and secure with the four screws (3).
12. Refit the Electrics and Pump Control Module (6) to the rear of the iL system and secure with the four screws (7): ensure that you do not trap any of the cables connected to the Module.

### 3.16.3 Connect the electrical supply to the iL system

#### WARNING

Connect the iL system to the electrical supply through a suitably rated isolator for your iL system (refer to Section 2.6).

#### WARNING

Ensure that your electrical supply cable is suitably protected against earth (ground) faults and that the earth (ground) conductor of the cable is longer than the phase conductors in the connector. You may want to fit a second protective earth (ground) conductor to the protective earth (ground) stud on the Electrics and Pump Control Module.

*Note: If you do not fit a second protective earth (ground) conductor, you must regularly check the earth (ground) continuity of the installation.*

(Continued on page 3-22)

Use the following procedure to connect the electrical supply to the iL system.

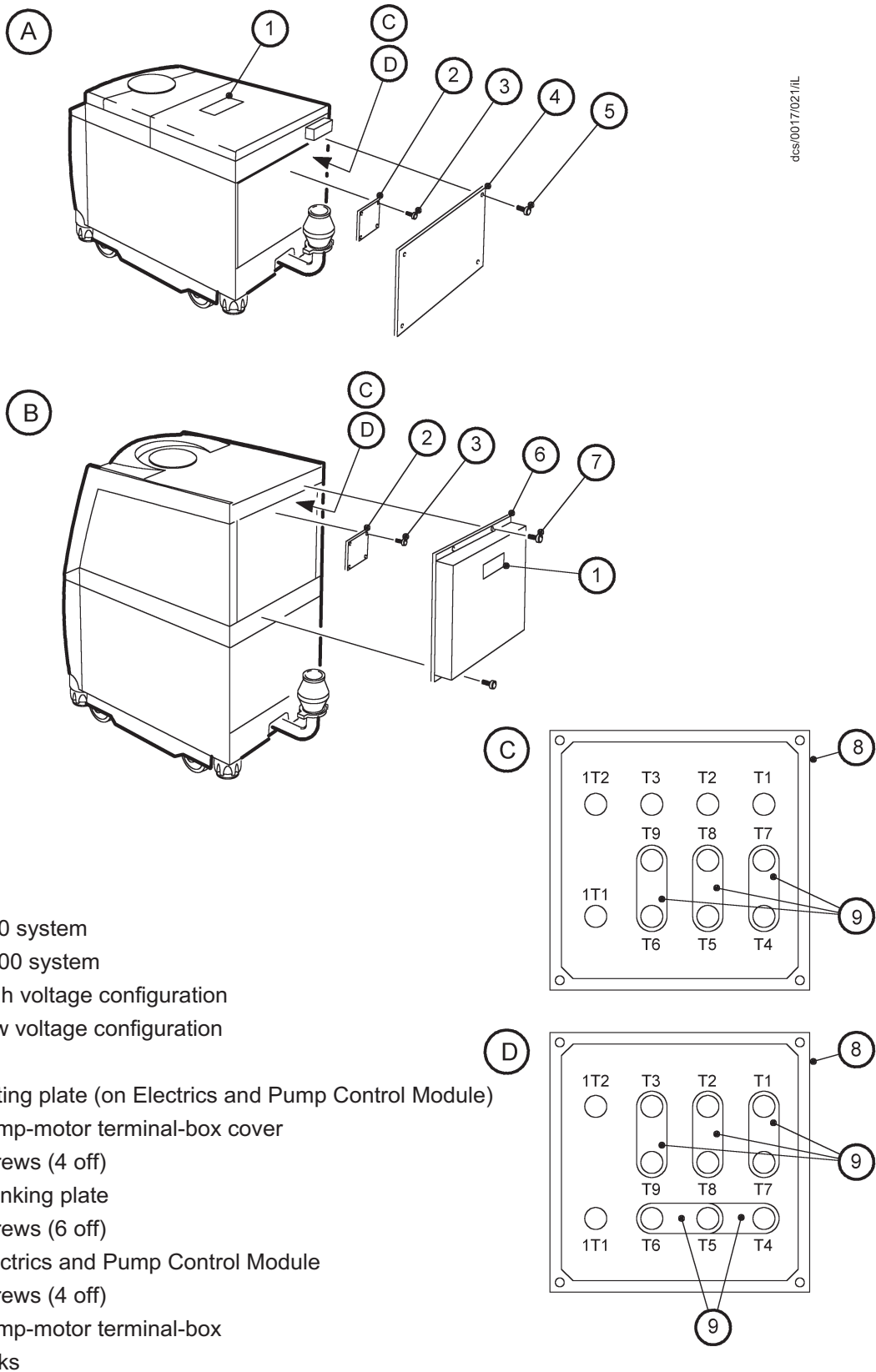

Figure 3-9 - Reconfigure the pump-motor terminal-box (if necessary)



The kit of parts supplied with the pump comprises a connector hood, the connector block, the gland body and five seal inserts of different sizes. The gland body and inserts are supplied together in a single bag. Select the correct size of insert to accommodate the cable, i.e. the size of insert that will only just fit onto to cable. A larger size will not provide an adequate grip of the cable and may allow moisture to penetrate the interior of the connector assembly.

When you make your electrical supply cable, ensure that the earth (ground) conductor is longer than the phase conductors. This will ensure that if the cable is accidentally dragged and the strain relief on the electrical supply connector mating-half gland fails, the earth (ground) conductor will be the last conductor to be pulled from the connector.

1. Refer to Figure 3-10. Remove the connector block (8) from the hood (7) of the mating-half electrical supply connector.
2. Remove the locking nut from the gland and pass the nut over the end of the cable.
3. Select the most suitable size of seal insert and pass that over the end of the cable, with the knurled end towards the cable end.
4. Fit the body of the gland to the hood, ensuring that it is securely fixed, insert the end of the cable through the gland and push the insert fully into the gland body. Then screw the locking nut onto the gland, but do not tighten the nut at this stage.
5. Connect the cable phase wires to the pins of the connector block (8), as shown in Table 3-4.
6. Connect the earth (ground) wire of the cable to one of the two earth (ground) screws (4) on the side of the connector block (8).
7. Refit the connector block (8) into the connector hood assembly (7), and tighten the gland locking nut (5).
8. Fit the mating-half assembly to the electrical supply connector (9) on the Electrics and Pump Control Module (10).
9. Connect the other end of the electrical supply cable to your electrical supply through a suitable isolator.
10. On pumping systems with variable speed or inverter drives, you must fit a second protective earth (ground) conductor to the protective earth (ground) stud on the Electrics and Pump Control Module (Figure 1-4, item 9) and connect the other end of this conductor to your factory earth (ground). On pumping systems that do not have variable speed or inverter drives, we recommend that you fit a second protective earth (ground) conductor.

Wire	Pin number (Figure 3-10 key)
Phase 1 (R)	1
Phase 2 (S)	2
Phase 3 (T)	3

Table 3-4 - Pins in the electrical supply connector

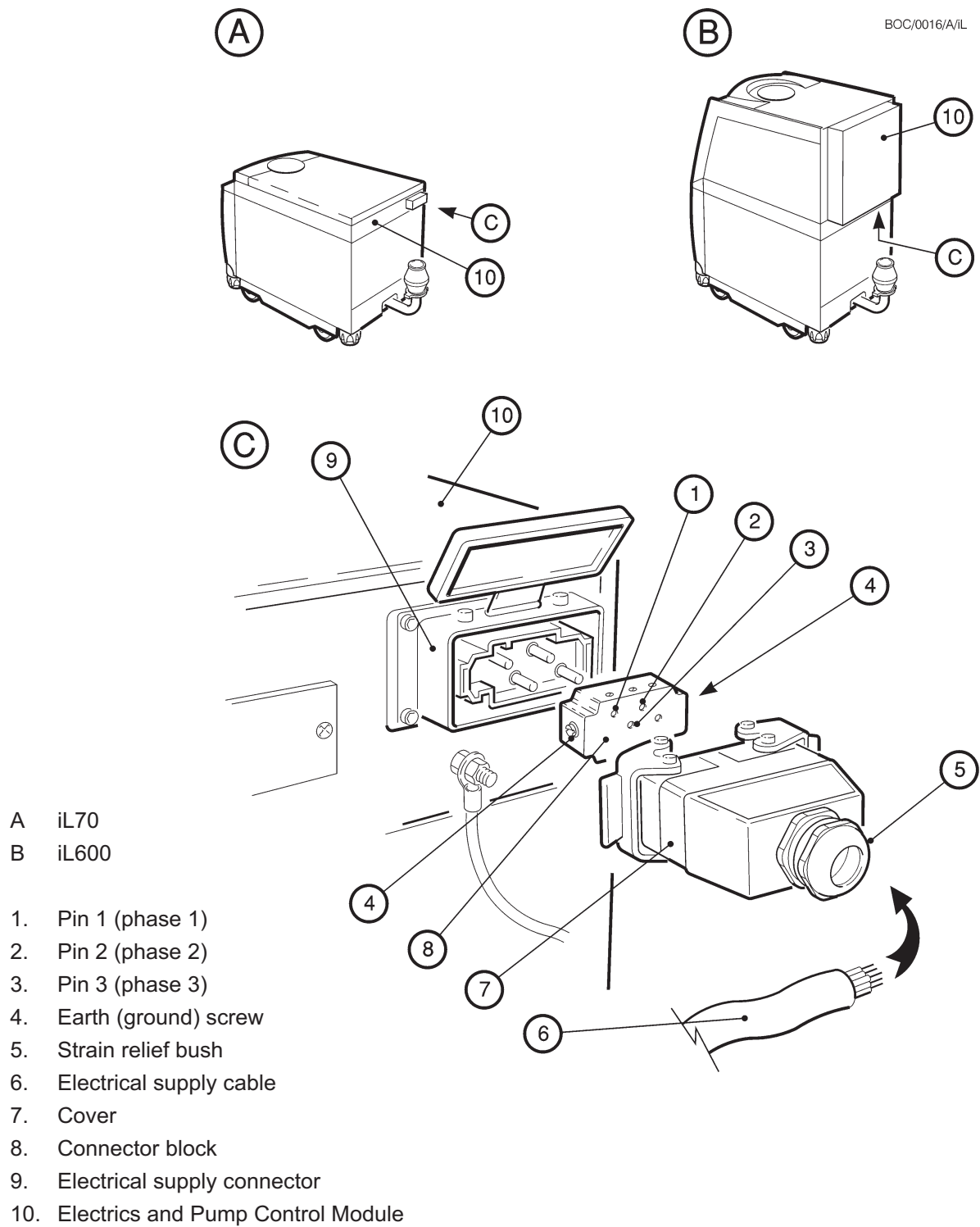

Figure 3-10 - Connect the electrical supply cable to the connector mating-half

### 3.16.4 Connect an additional RF earth (optional)

An earth (ground) cable is connected to the rear of the M6 RF earth (ground) stud on the rear panel of the iL system (Figure 1-4 item 6). If you will operate the iL system in an area subject to high RF (radio frequency) emissions, in accordance with good RF installation practise, we recommend that you:

Use a star washer to connect the end of the earth (ground) cable connected to the iL inlet to one of the bolts that you use to secure the inlet-flange (see Section 3.9).

Connect an additional earth (ground) cable to the M6 RF earth (ground) stud. You must use a suitable low-impedance cable (for example, use braided cable).

### 3.17 Refit the enclosure panels

1. Refer to Figure 3-3, detail A (iL600) or detail B (iL70). Refit the top panel:

Place the front of the top panel (1) on the top of the iL system.

Lower the rear of the panel so that it is horizontal, then slide it forward (towards the iL inlet) until it is fully in place.

Use a flat-bladed screwdriver to secure the two quarter-turn catches (2) on the end of the top cover.

2. Refer to detail B. Refit the LCDP right-hand side panel:

Hold the panel (4) and fit it to the side of the iL system, so that the locating plates on the frame (5) engage in the slots in the bottom of the panel (4).

Lower the panel fully down, then swing the top of the panel into place against the frame.

Use a flat-bladed screwdriver to secure the two quarter-swing catches (3).

3. Refit the LCDP left-hand side panel: use the method in Step 2.
4. If you have an iL600 system, continue at Step 5, otherwise continue at Section 3.18.
5. Refer to detail A. Refit the LCMB right-hand side panel: use the method in Step 2.
6. Refit the LCMB left-hand side panel: use the method in Step 2.

### 3.18 Connect the cooling-water pipelines

#### WARNING

Do not turn on the cooling-water supply until after you complete the electrical installation of the pump. If you do, condensation may form inside the motor terminal-box and there may be a risk of electric shock.

#### CAUTION

Drain the cooling-water from the iL system, if you want to transport or store it in conditions where the cooling-water could freeze. If you do not, cooling-water may freeze in the iL system and damage the pump(s) and/or the cooling-water pipelines.

*Notes: For optimum water-cooling, ensure that your cooling-water supply and return pipelines are free of restrictions which would reduce the cooling-water flow rate. If you need to connect more than one iL system to the water supply, you must connect them in parallel and not in series.*

Connect the cooling-water supply as described below:

1. Use  $\frac{3}{8}$  inch BSP male pipe fittings (which you must supply) to fit the female quick-release connector to your cooling-water supply pipeline and to fit the male quick-release connector to your cooling-water return pipeline.
2. Refer to Figure 1-4. Remove the dust-caps from the cooling-water outlet (2) and inlet (3).
3. Connect your cooling-water return pipeline to the cooling-water outlet (2) and connect your cooling-water supply pipeline to the cooling-water inlet (3).
4. Turn on the cooling-water supply.
5. Inspect your cooling-water pipelines, the cooling-water hoses on the iL system and all of the cooling-water connections and check that there are no leaks. Seal any leaks found.
6. Turn off the cooling-water supply while you complete the installation procedures.

### 3.19 Commission the iL system

WARNING

Do not operate the iL system with the exhaust pipeline blocked. If the exhaust pipeline is blocked, the iL system can generate exhaust pipeline pressures up to 4 bar ( $4 \times 10^5$  Pa)

WARNING

Do not operate the iL system with any enclosure panels removed and do not touch any parts of the pump(s) when the iL system is on. Surfaces of the pump(s) are very hot and can cause injury to people.

### 3.19.1 Switch on an iL70 system

1. Switch on the external electrical supply and check that the power on lamp (Figure 1-4, item 7) goes on. If the lamp does not go on, refer to Section 6 to determine the cause of the fault.
2. Switch on the cooling-water supply and nitrogen supply on sensor configured systems.
3. Ensure that the exhaust-extraction system is not blocked (for example, that valves in the exhaust-extraction system are open).
4. Ensure that all openings to atmospheric pressure in the foreline vacuum system are closed, then switch on the iL system.
5. If the iL system starts and continues to operate, continue at Step 6. If a warning or alarm condition is indicated (for example, a warning or alarm message is shown on the Pump Display Module):
  - Shut down the iL system: refer to Section 5.8.
  - Refer to Section 6 to determine the cause of the fault and to rectify the fault.
6. Look at the pressure gauge in your inlet pipeline:
  - If the pressure is increasing, the LCDP pump-motor terminal-box is incorrectly wired: immediately shut down the iL system, correct the electrical wiring (refer to Section 3.16.2), then repeat this procedure from Step 3 again.
  - If the pressure is decreasing, continue at Step 7.
7. After you have commissioned the iL system:
  - If you want to continue to operate the iL system, refer to Section 5.
  - Otherwise, shut down the system: refer to Section 5.8.

### 3.19.2 Configure and switch on an iL600 system

CAUTION

Ensure that the booster start delay is correctly adjusted for your installation. If it is not, you may damage the iL system when you start it up.

CAUTION

You can only use the following procedure to configure an iL600 system if you have a Single Pumpset Monitor (SPM) connected to the iL system. If you do not have SPM, you cannot use the following procedure: contact your supplier or BOC Edwards for advice.

CAUTION

Do not operate an iL600 system with the maximum inlet pressure for longer than the maximum time specified in Table 2-1. If you do, the LCMB pump may overheat.

*Note:* You will need a stop-watch to do the following procedure, which assumes that you are familiar with the operation of the SPM; where necessary, refer to the instruction manual supplied with the SPM.

*You can adjust the iL booster start delay up to a maximum of 65535 seconds.*

When you switch on an iL600 system, the LCDP pump starts immediately, but there is a delay before the LCMB pump is started. This is to ensure that the vacuum system and vacuum inlet pipelines are partially evacuated by the LCDP pump, so that the maximum inlet pressure for the LCMB pump is not exceeded (see Section 2). As supplied, this delay (the booster start delay) between LCDP pump switch-on and LCMB pump switch-on is preset to 30 seconds.

You must use the following procedure to determine whether the booster start delay is suitable for your installation.

1. Switch on the external electrical supply and check that the power on lamp (Figure 1-4, item 7) goes on. If the lamp does not go on, refer to Section 6 to determine the cause of the fault.
2. Logon to the SPM.
3. Use the SPM to:

Upload the configuration set from the iL system, and store it with a suitable file name (for example, "iL600").

Edit the configuration to identify that an LCMB pump is not fitted, and save the new edited configuration set with a suitable new file name (for example, "iL70/600").

Download the edited configuration set to the iL system.

4. Switch on the cooling-water supply and nitrogen supply on sensor configured systems.

5. Ensure that the exhaust-extraction system is not blocked (for example, that valves in the exhaust-extraction system are open).
6. Ensure that all openings to atmospheric pressure in the foreline vacuum system are closed, then switch on the iL system and simultaneously start the stop-watch.
7. If the iL system starts and continues to operate, continue at Step 8. If a warning or alarm condition is indicated (for example, a warning or alarm message is displayed on the SPM or shown on the Pump Display Module):
  - Shut down the iL system: refer to Section 5.8.
  - Refer to Section 6 to determine the cause of the fault and to rectify the fault, then repeat this procedure from Step 5.
8. Look at the pressure gauge in your inlet pipeline:
  - If the pressure is increasing, the LCDP pump-motor terminal-box is incorrectly wired: immediately shut down the iL system, correct the electrical wiring (refer to Section 3.16.2), then repeat this procedure from Step 5 again.
  - If the pressure is decreasing, leave the iL system to operate and take note of the time taken to pump down to 5 mbar ( $5 \times 10^2$  Pa), then continue at Step 9.
9. Stop the iL system and isolate it from the electrical supply.
10. Add 10% to the time noted in Step 8, to give the required booster start delay for your installation.
11. If the required booster start delay is less than or equal to 30 seconds, continue at Step 13.
12. If the required booster start delay is greater than 30 seconds, use the SPM to edit and save the original configuration set uploaded from the iL (the set saved as, for example, "iL600"): set the BOOSTER START DELAY of BOOSTER PUMP CONTROL to the required booster start delay time.
13. Use the SPM to download the original configuration set (with file name, for example, of "iL600") to the iL system.
14. Start up the iL system again and at the same time start the stop-watch. Watch the pressure gauge in your inlet pipeline. The LCDP pump will start and the pressure will start to reduce. After the booster start delay time, the LCMB pump will start (at an inlet pressure of approximately 5 mbar,  $5 \times 10^2$  Pa):
  - If the pressure increases or does not decrease any further when the LCMB pump starts, the LCMB pump-motor terminal-box is incorrectly wired: immediately shut down the iL system, correct the electrical wiring (refer to Section 3.16.2), then repeat this procedure from this step (Step 14) again.
  - If the pressure continues to decrease after the LCMB pump starts, continue at Step 15.
15. After you have commissioned the iL system:
  - If you want to continue to operate the iL system, refer to Section 5.
  - Otherwise, shut down the system: refer to Section 5.8.

## 4 PUMP DISPLAY MODULE MENUS AND DISPLAY FORMATS

### 4.1 Introduction

The menus used and the display messages shown on the Pump Display Module are described in the menu diagrams in Figures 4-2 to 4-19. The following symbols and conventions are used in the menu diagrams:

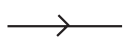

These are flow lines. Arrows on the lines show the direction of flow through a menu.



This symbol is used to connect different menus and shows the starting point (or continuation point) of a menu. The symbol is shown with the menu name and, where applicable, a reference of the form [4-x/y]. This reference specifies that the menu continues on (or is continued from) a menu shown on sheet y of Figure 4-x. The sheet reference (/y) is omitted where it is not necessary.



This symbol is used for the ENTER and CANCEL buttons and the four menu buttons: Normal, Status, Control and Setup.



This symbol is used for the up (▲) and down (▼) buttons and for the on (◀▶) and off (○) buttons.



This symbol is used for the two-line display on the Pump Display Module. With the exception of variable text (see Section 4.4), the text shown in the symbol is the text that will be shown on the display.

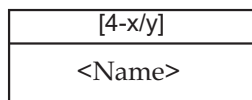

This symbol is a subroutine box and is used to represent a 'subroutine call'; a subroutine is a series of menu steps which are used in a number of different menus or used in different parts of one menu. The [4-x/y] reference (used as described above) shows where the subroutine is expanded.

In a menu which 'calls' a subroutine, where a menu flow line meets the left hand side of a subroutine box, this means that flow continues at the start connector (identified by <name>) of the subroutine. At the 'exit' connector of the subroutine, flow continues in the (calling) menu along the flow line to the right of the subroutine box.



This symbol shows additional text which is not part of the menu, but which further describes the operation of the menu.



## 4.2 General operation

When you first switch on the iL system, the normal display is shown: see Figure 4-5. Refer to Figure 4-1. You can then press the On or Off button (1 or 10) or any of the four menu buttons (7) to enter the corresponding menu. Then, regardless of the current menu and display status, when you press any of these buttons, you exit the current menu and enter the corresponding new menu. Figure 4-2 shows this menu control logic.

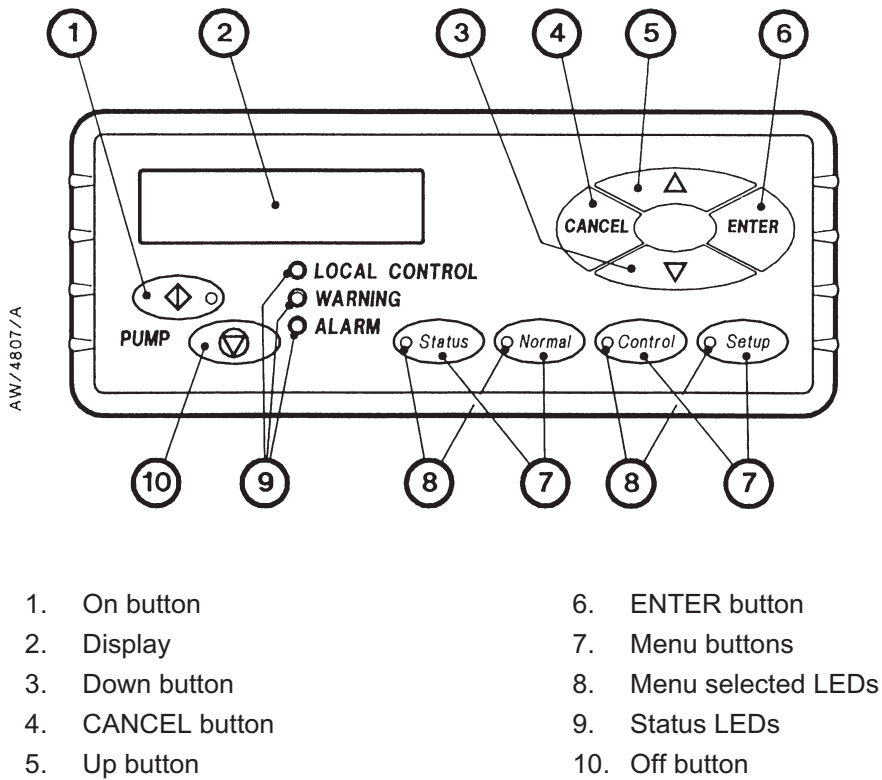

Figure 4-1 - Front panel of the Pump Display Module (optional accessory)

### 4.3 The CANCEL button

You can press the CANCEL button at any time during menu operation. For this reason, we have not shown the use of the CANCEL button on all of the menu diagrams, but we have shown specific uses where there is no other obvious way to cancel the current menu option and enter the previous menu option. In general, when you press the CANCEL button, the current menu option is cancelled and the previous menu option is displayed. Other specific uses of the CANCEL button are as follows:

In the Switch On and Switch Off menus (Figures 4-3 and 4-4), when you press CANCEL, the menu is exited and the normal display is shown.

In the Status menu (Figure 4-6), when you press CANCEL the display shows the first two status parameters (the defaults are LCDP current consumption and power consumption).

When you change passwords in the Setup and Service menus (Figures 4-8 and 4-12) and before you press the ENTER button, if you press CANCEL, the menu moves back to entry of the first digit of the password or serial number.

### 4.4 Display text and variable text

In the menu diagrams in Figures 4-2 to 4-19, text shown without chevron brackets in the two-line display symbol is the actual text that will be shown on the display. In this text, the ' ' symbol is used to show where a digit will be shown; the value of the digit depends on the sensor data or information you enter into the Pump Display Module.

Text enclosed in chevron brackets (for example, <status>) defines variable text; what is shown on the display depends on the menu or the status of the iL system and data entered by the user. The following variable text markers are used on the menu diagrams:

- |                  |   |
|------------------|---|
| <status>         | This specifies the status of a sensor in the iL. <status> can be any of the following:<br><br>OK indicates that the status is acceptable.<br>CHECK or LOW indicates that the reading from the sensor is low.<br>NP (not present) indicates that the sensor is not fitted.<br>NR (not reading) indicates that the sensor is disconnected, faulty or not switched on. |
| <serial no./tag> | This specifies a serial number or the user tag. The user tag is a number which you can use to identify the iL system in the installation.   |
| <parameter>      | This is a previously selected parameter or menu option.   |
| <message>        | This specifies a warning, alarm or advisory message.  |
| <e.no>           | This specifies an error number: refer to Section 6.   |
| <units>          | This specifies setpoint units, for example kW or slm.   |

## 4.5 Wrap-around

When you use the up and down buttons to change a digit or character on the display, the digit or character will 'wrap-around' between its minimum and maximum values. For example, when you enter a password digit, if the digit is '0' and you press the down button, the digit will change to '9'; if the digit is '9' and you press the up button, the digit will change to '0'.

## 4.6 Timeout

As supplied, after you have entered a menu (other than the Normal menu), if you do not press a button for five minutes, the Pump Display Module will automatically exit the current menu and enter the Normal menu. This facility (known as timeout) is available so that if the setup or service menu is entered and then the iL system is accidentally left unattended for a specified time, the menu is exited to prevent unauthorised use of the menu options.

## 4.7 Menu structure

The menu structure is shown in Table 4-1. Note that if a particular system component or accessory is not fitted, the corresponding menu option or parameter is not shown or is shown as 'NP' (not present). For example, in the Status menu (Figure 4-6), if a component is not fitted, 'NP' (not present) is shown in the corresponding display line; so, if the iL system does not have an oil monitor fitted to the LCDP pump, where Figure 4-6 shows the 'DP OIL' status display, the actual display line will be 'DP OIL      NP'.

Note also that there are menus which, though programmed into the software in the iL system, have no effect on iL operation.

## 4.8 Example

Here is an example of how to interpret the menu diagrams. The following procedure describes how to change the units displayed for pressures (you can select kPa or psi).

1. Press the Setup button to enter the Setup menu (Figure 4-8).
2. Use the up and down buttons to change the first digit of the setup password to the correct value, then press the ENTER button.
3. Use the up and down buttons to change the second digit of the setup password to the correct value, then press the ENTER button.
4. Use the up and down buttons to change the third digit of the setup password to the correct value, then press the ENTER button.
5. If you have entered the correct password, the display will then show 'SETUP MENU' on the top line and 'Inlet Purge' on the bottom line.
6. Press the down button six times or press the up button five times; the display will then show 'SETUP MENU' on the top line and 'Units' on the bottom line.
7. Press the ENTER button; the display will then show 'Units Select' on the top line and 'Pressure' on the bottom line (see Figure 4-10).

8. Press the ENTER button; the display will then show 'Pressure' on the top line and the currently selected pressure units on the bottom line.
9. Press the up or down buttons to change the units displayed to the required units, then press the ENTER button. Pressures will now be displayed in the units you selected.

Menu	Figure
Switch on	4-3
Switch off	4-4
Normal	4-5
Status	4-6
Control	4-7
Setup	4-8
Inlet purge	4-8
Gas Ballast	4-8
Gate Valve 1	4-8
Gate Valve 2	4-8
Run Til Crash	4-9
Units	4-10
Normal display	4-11
Service	4-12
Serial Numbers	4-13
Zero sensors *	4-14
Gas Valve Contrl *	4-15
Manual	4-16
View Status	4-17
Messages	4-18
Warning and alarm messages	4-19

\* These menus are not used in the iL system.

Table 4-1 - Menu structure

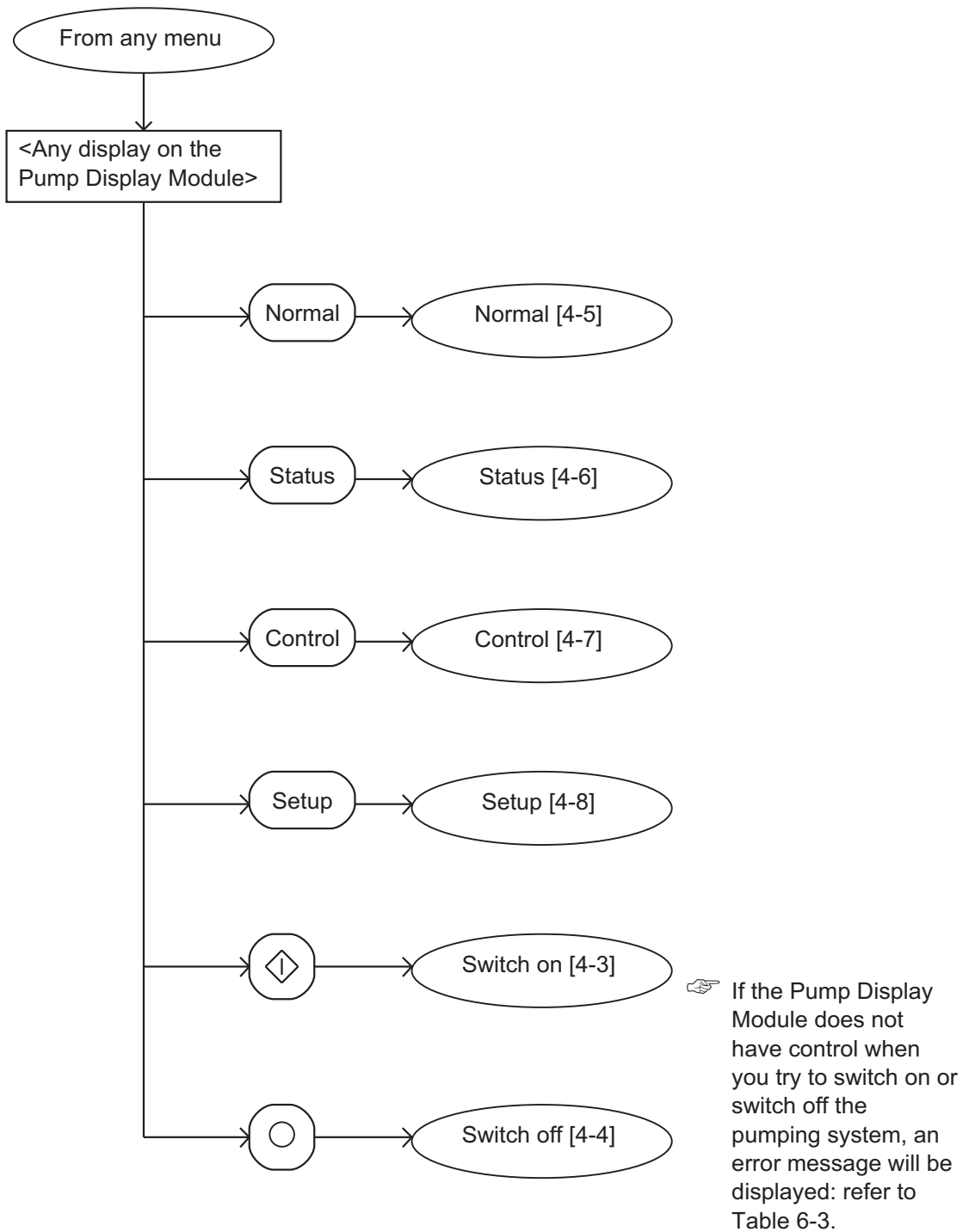

Figure 4-2 - Menu logic

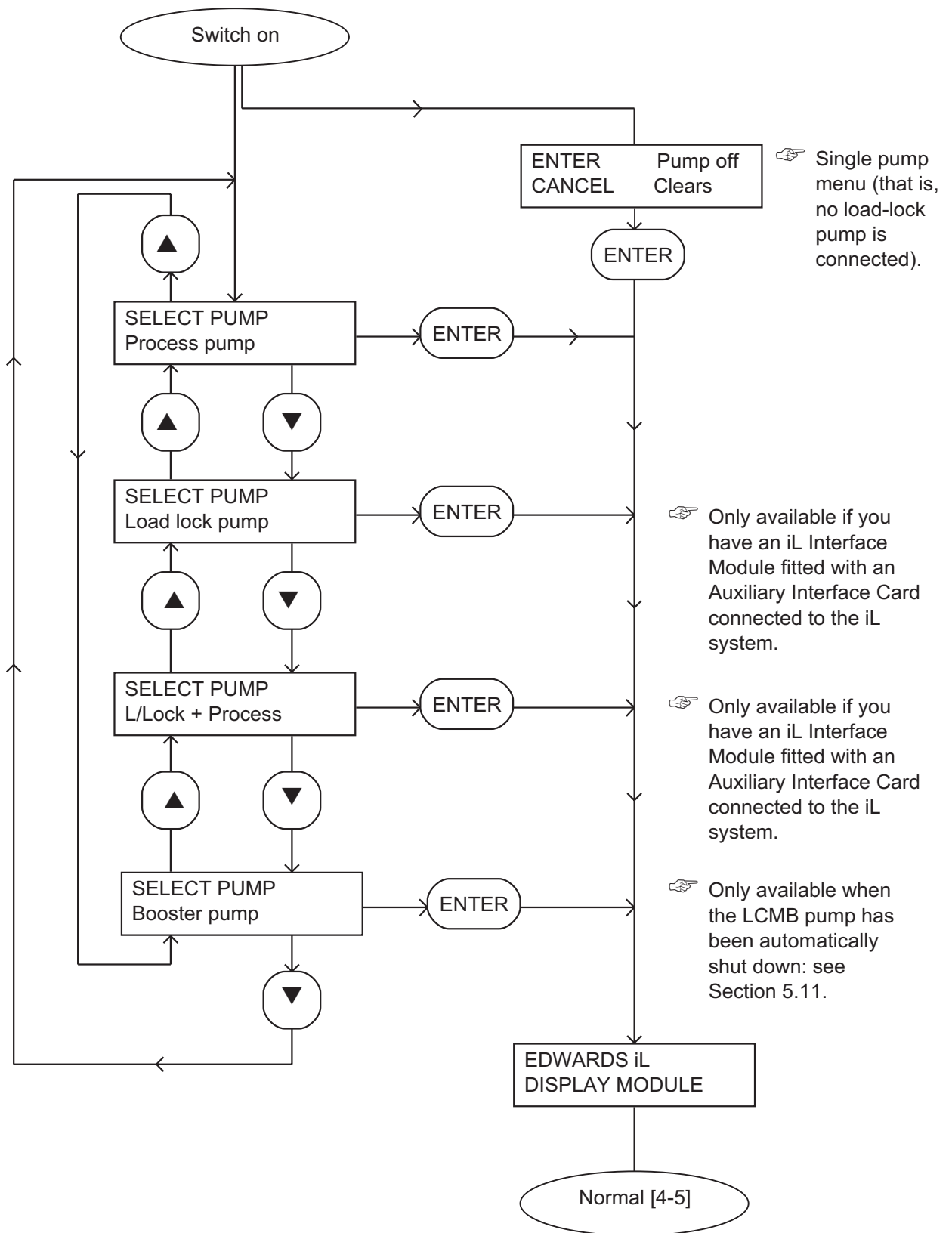

Figure 4-3 - Switch on menu

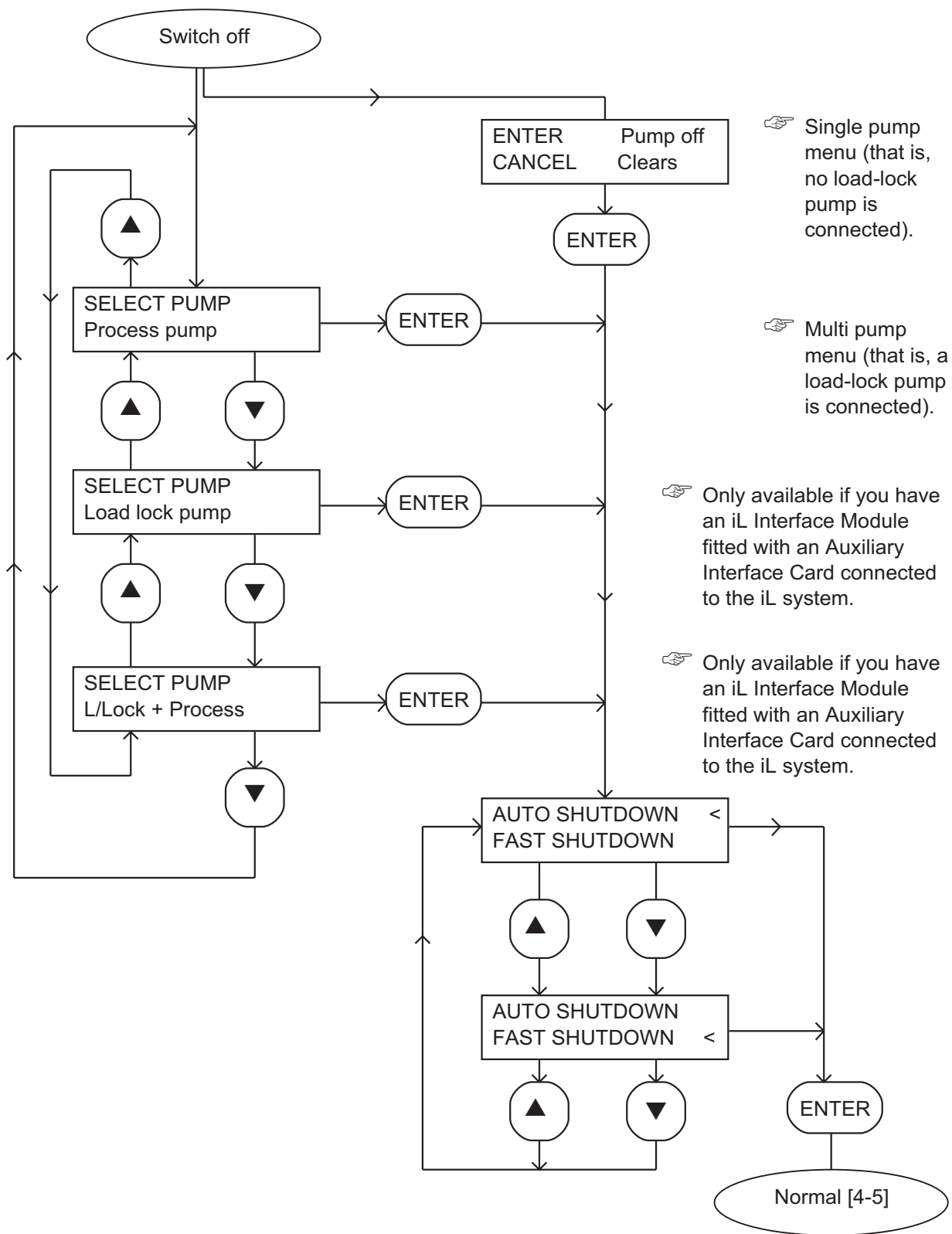
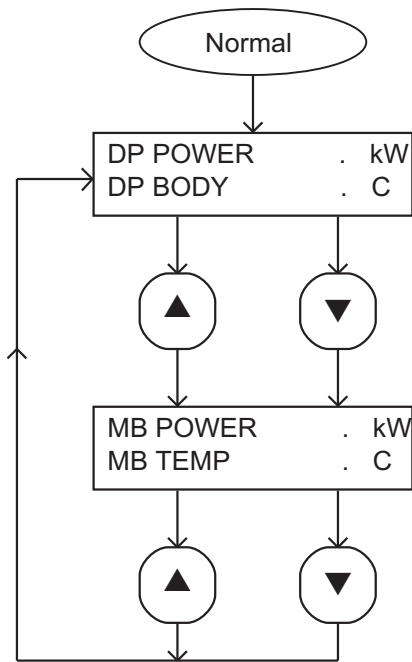

Figure 4-4 - Switch off menu



☞ First page of the normal display

☞ On a standard iL system, <NP> will be shown instead of a temperature value.

☞ Second page of the normal display.

☞ On a standard iL system, <NP> will be shown instead of a temperature value.

☞ To change the information shown on the two pages, refer to Section 5.

Figure 4-5 - Normal menu



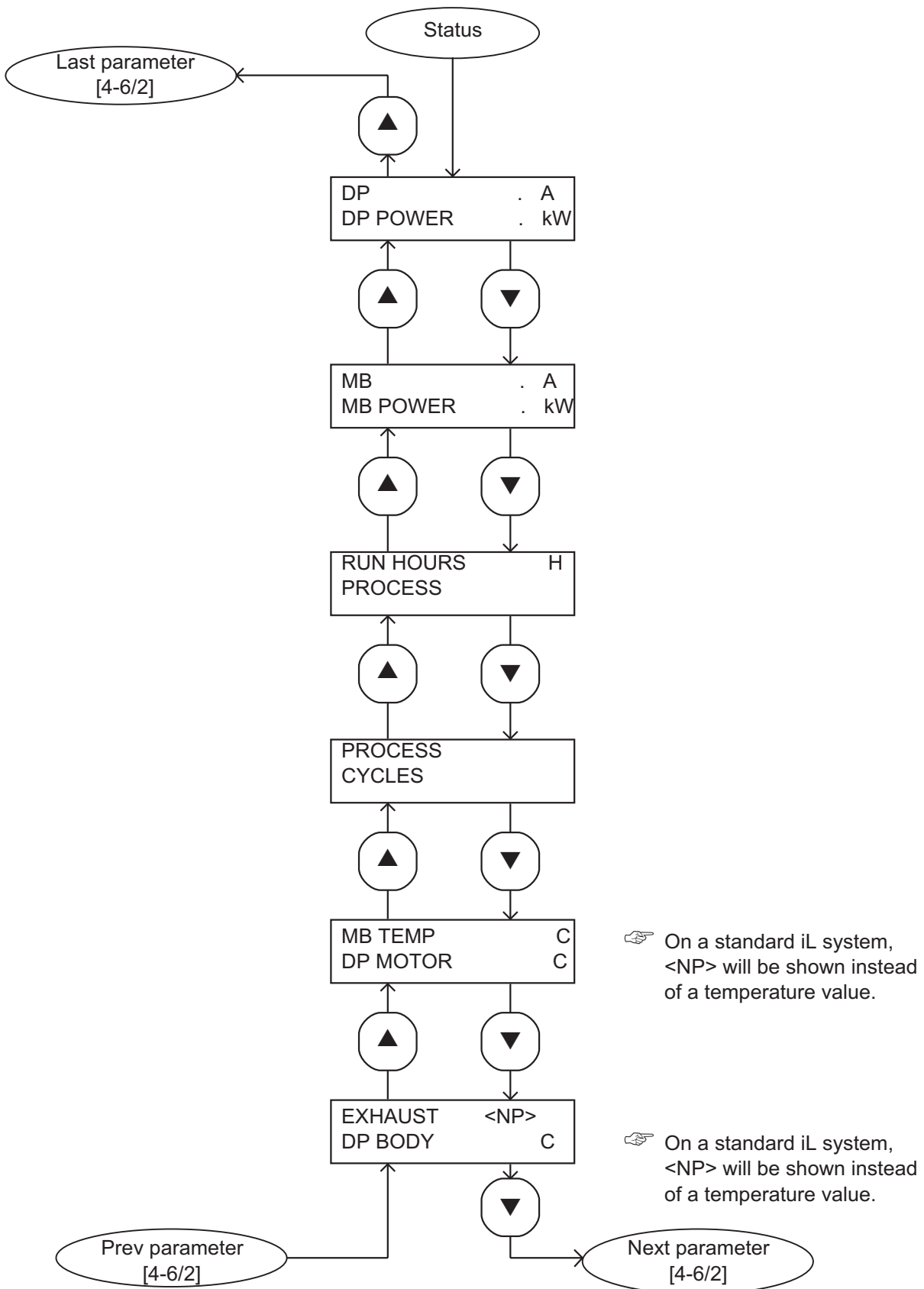

Figure 4-6 - Status menu: sheet 1 of 2

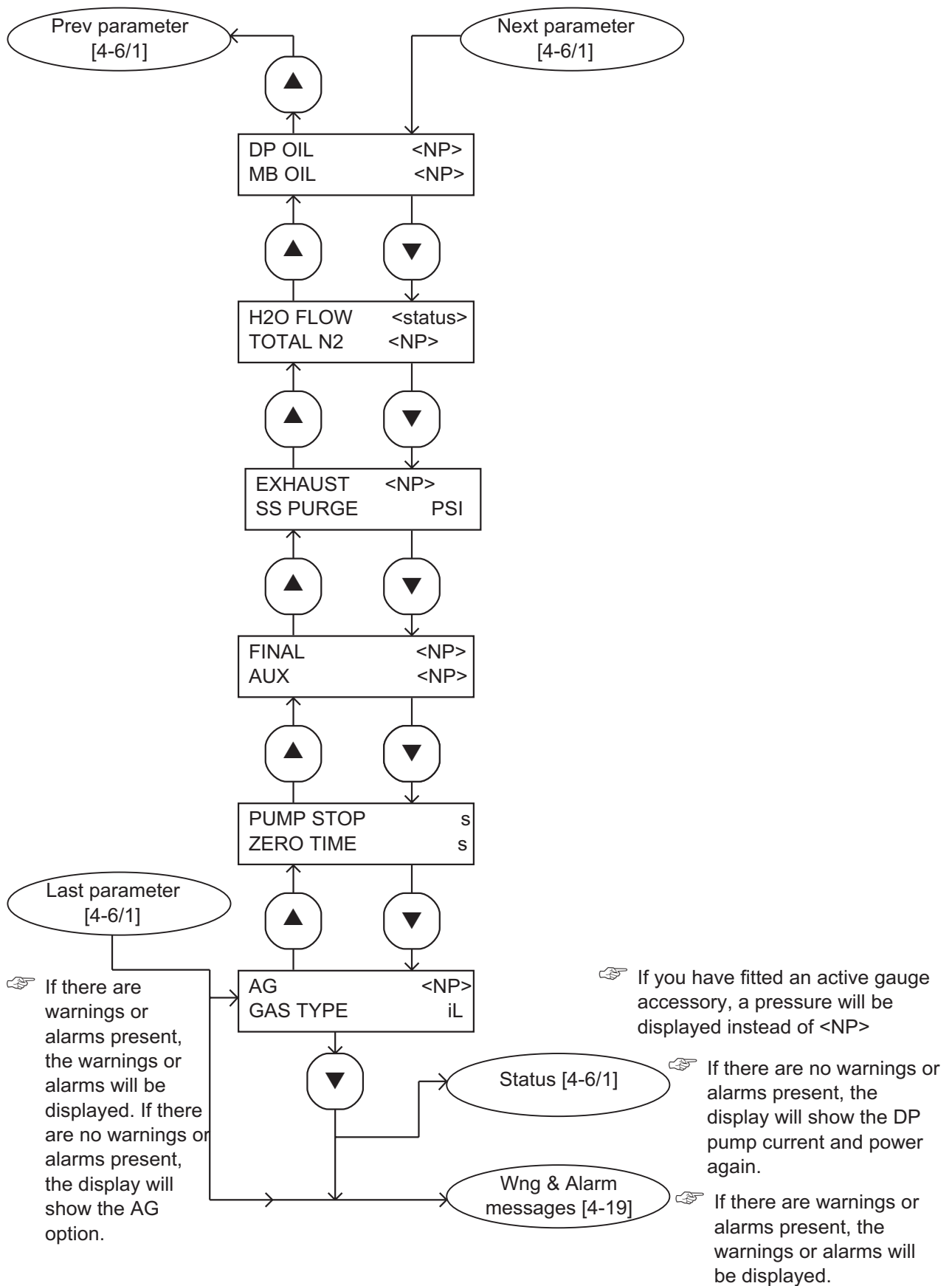

Figure 4-6 - Status menu: sheet 2 of 2

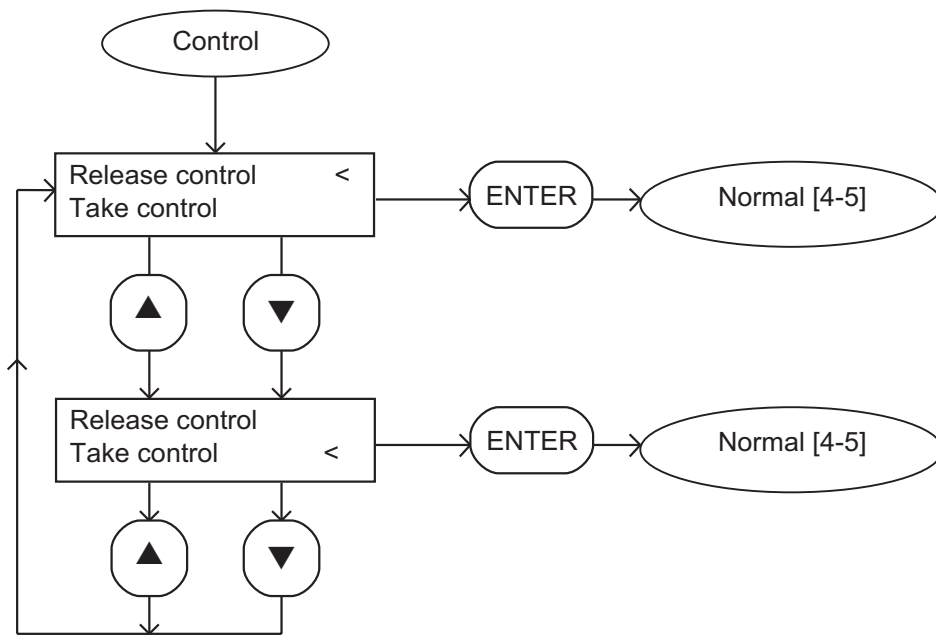

Figure 4-7 - Control menu

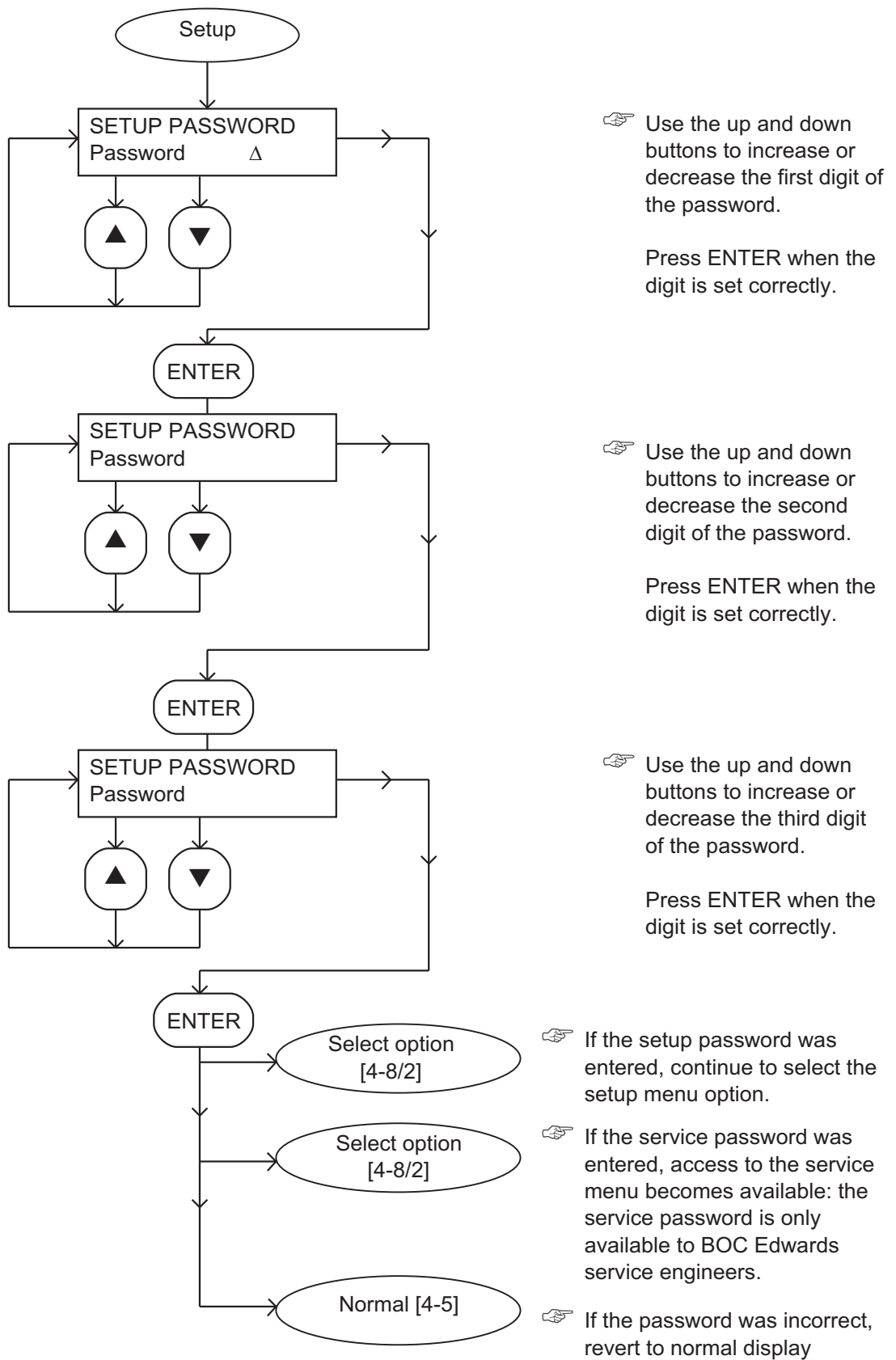

Figure 4-8 - Setup menu: sheet 1 of 3

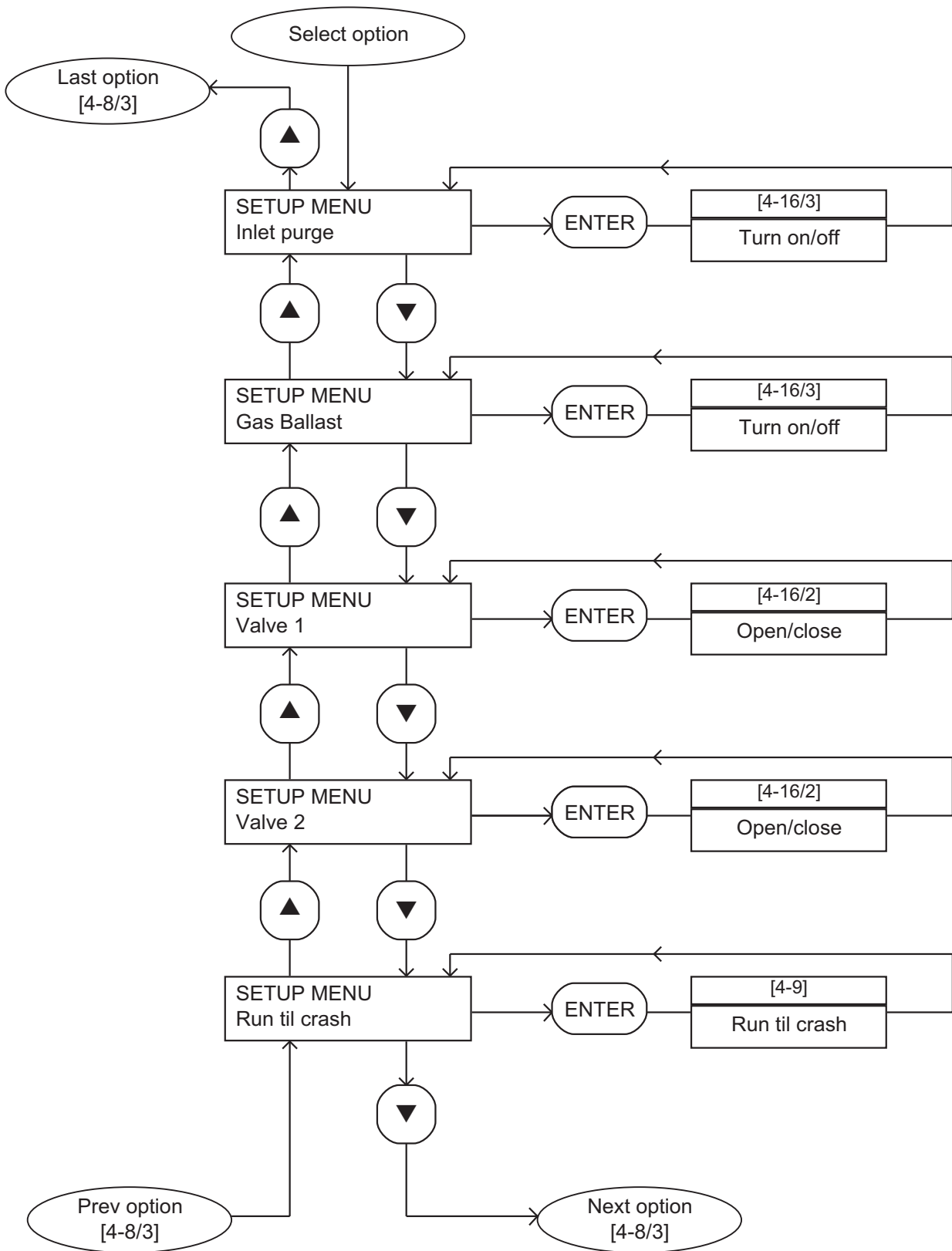

Figure 4-8 - Setup menu: sheet 2 of 3

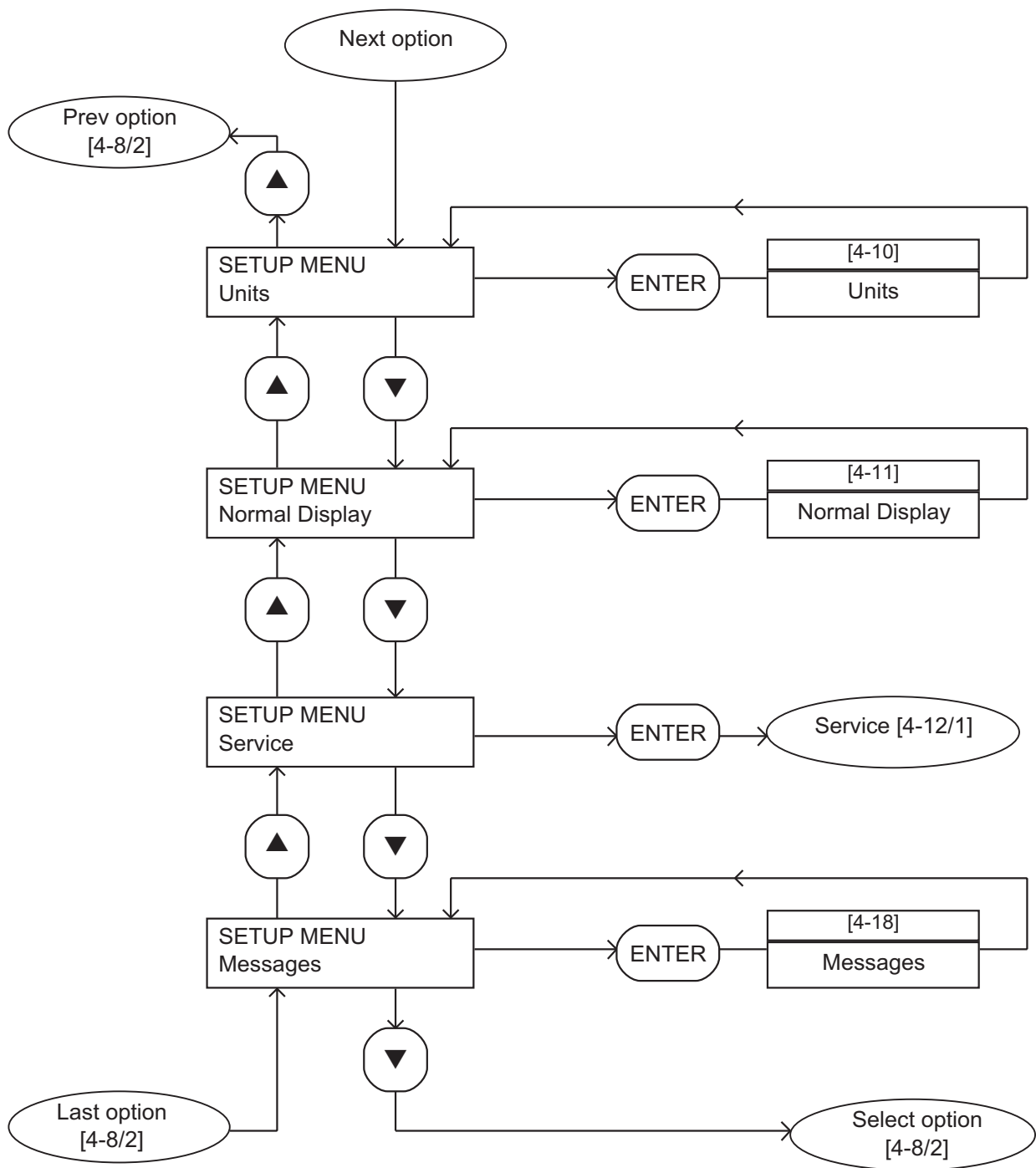

Figure 4-8 - Setup menu: sheet 3 of 3

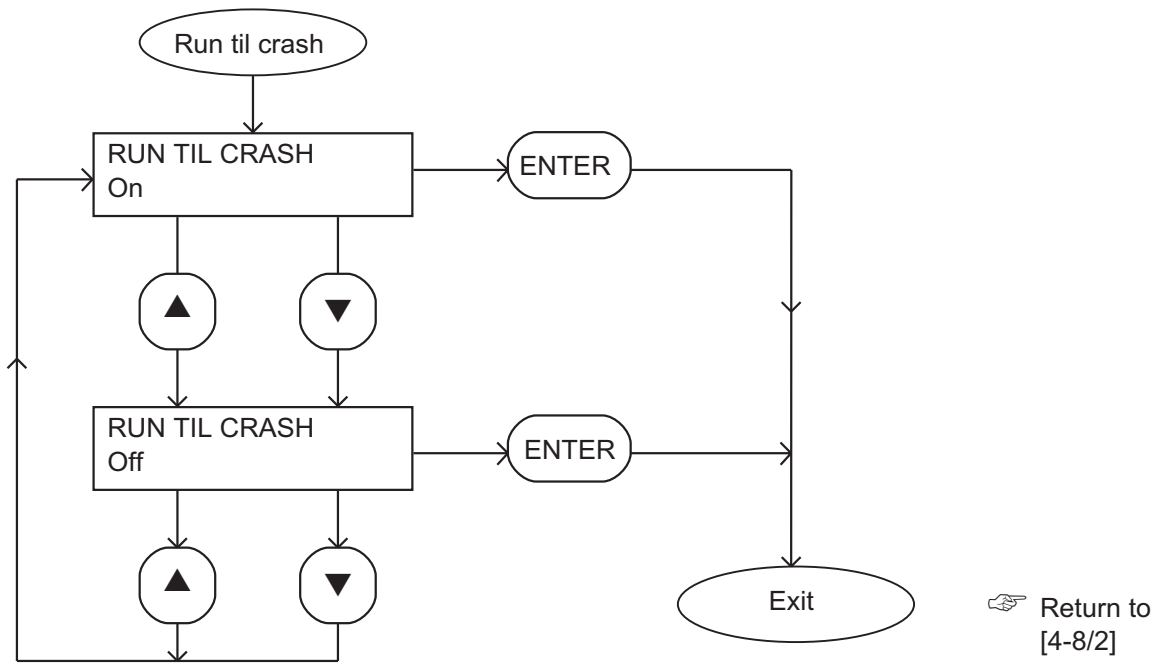

Figure 4-9 - Run til crash menu

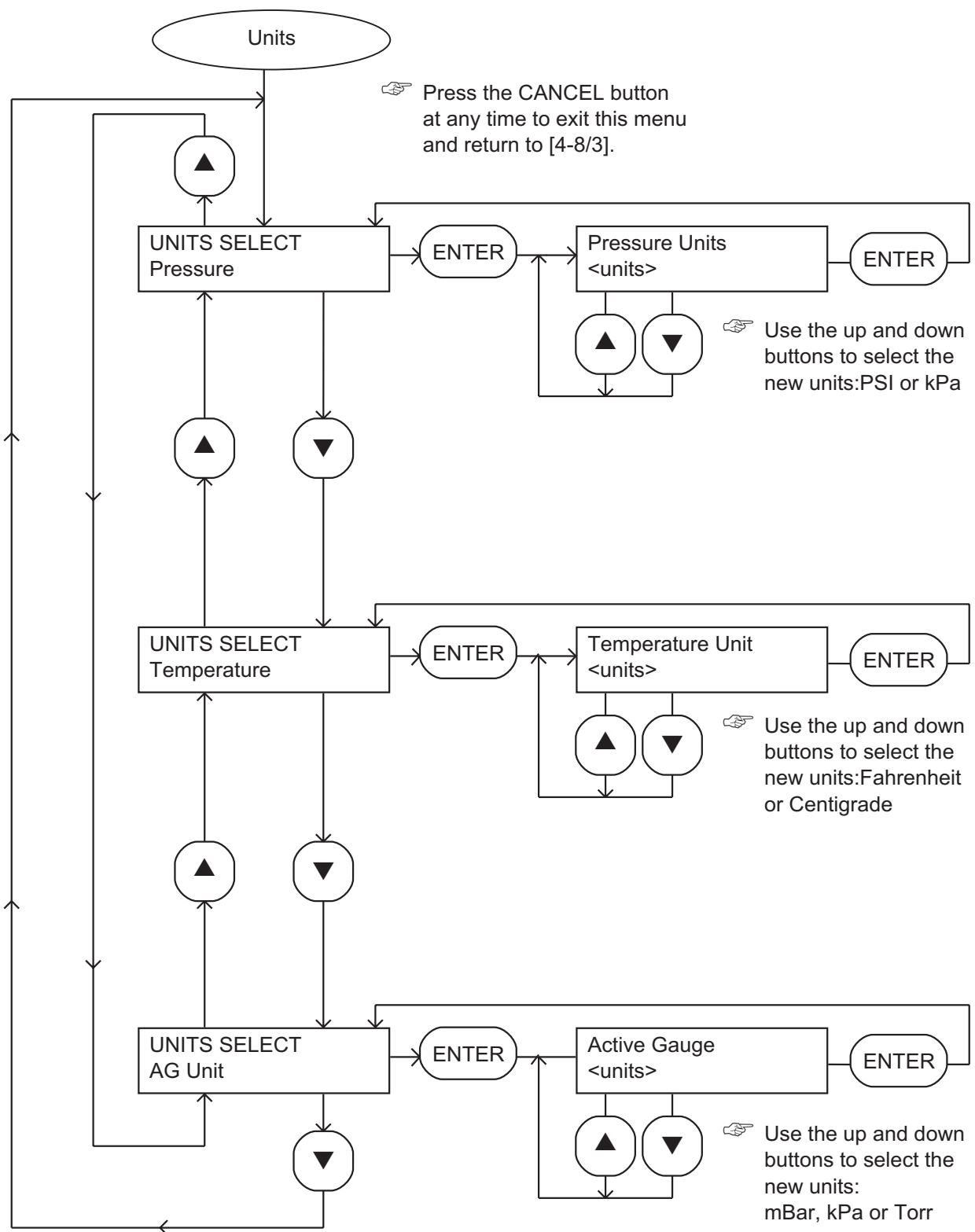

Figure 4-10 - Units menu



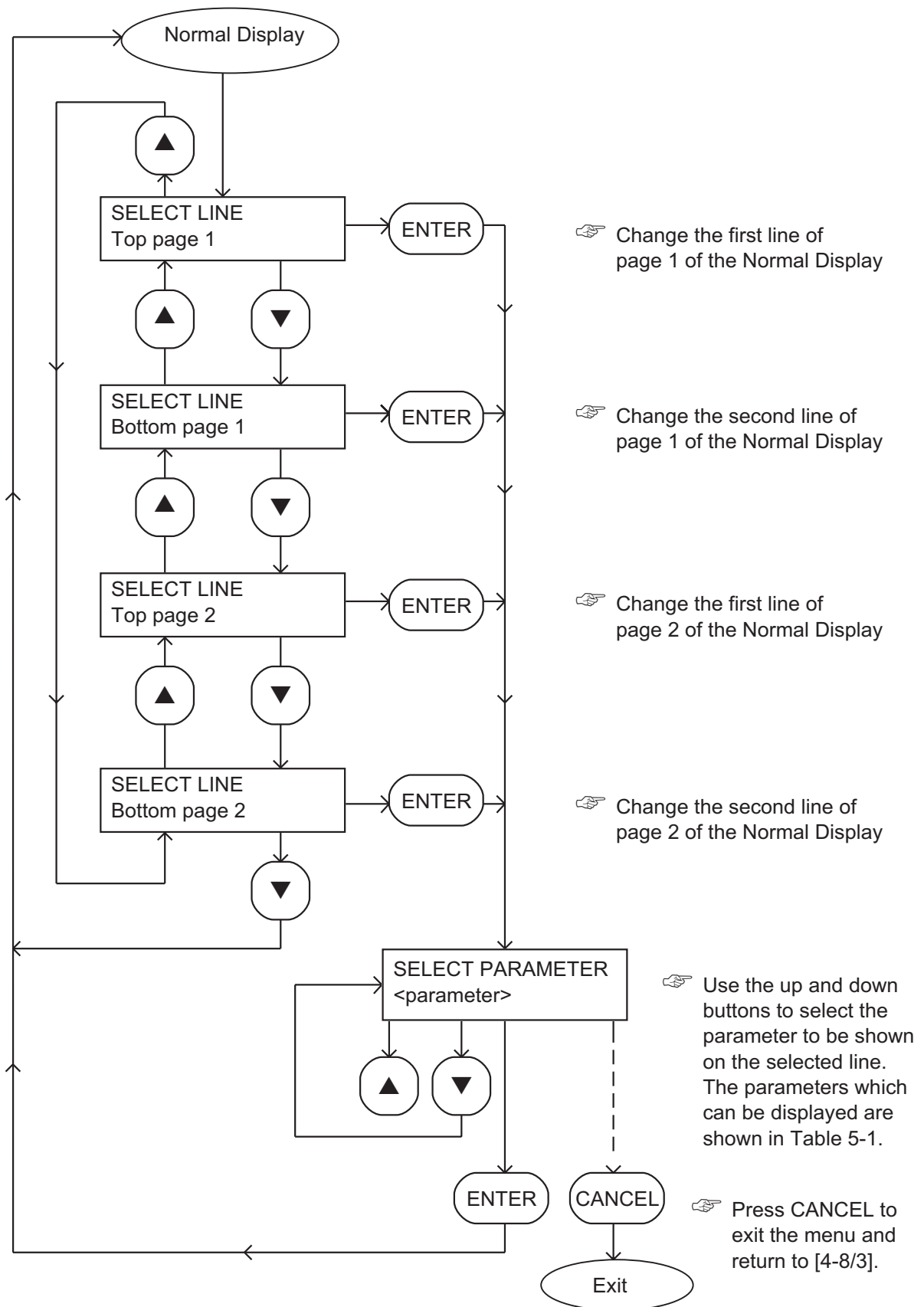

Figure 4-11 - Normal display menu

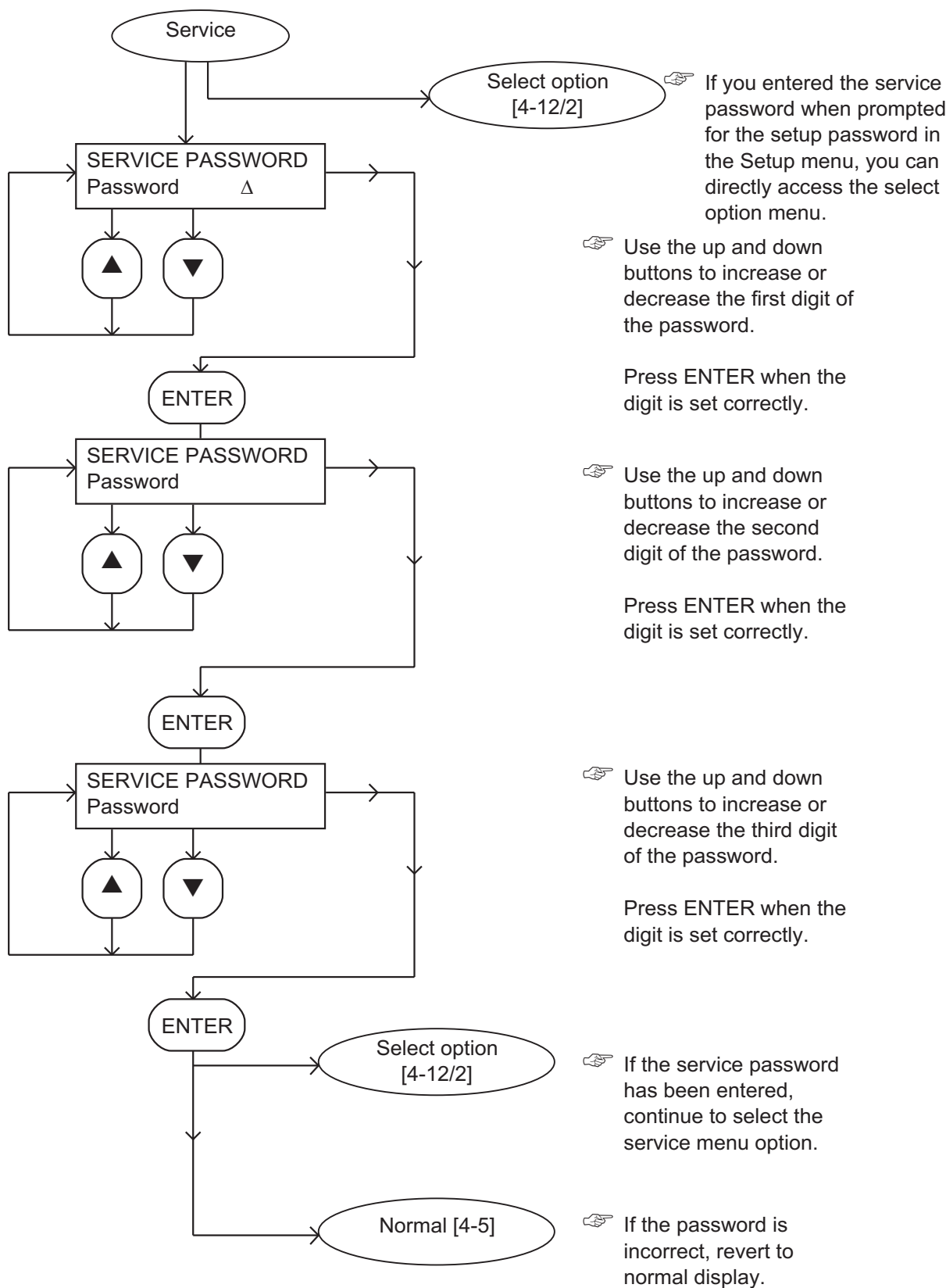

Figure 4-12 - Service menu: sheet 1 of 2

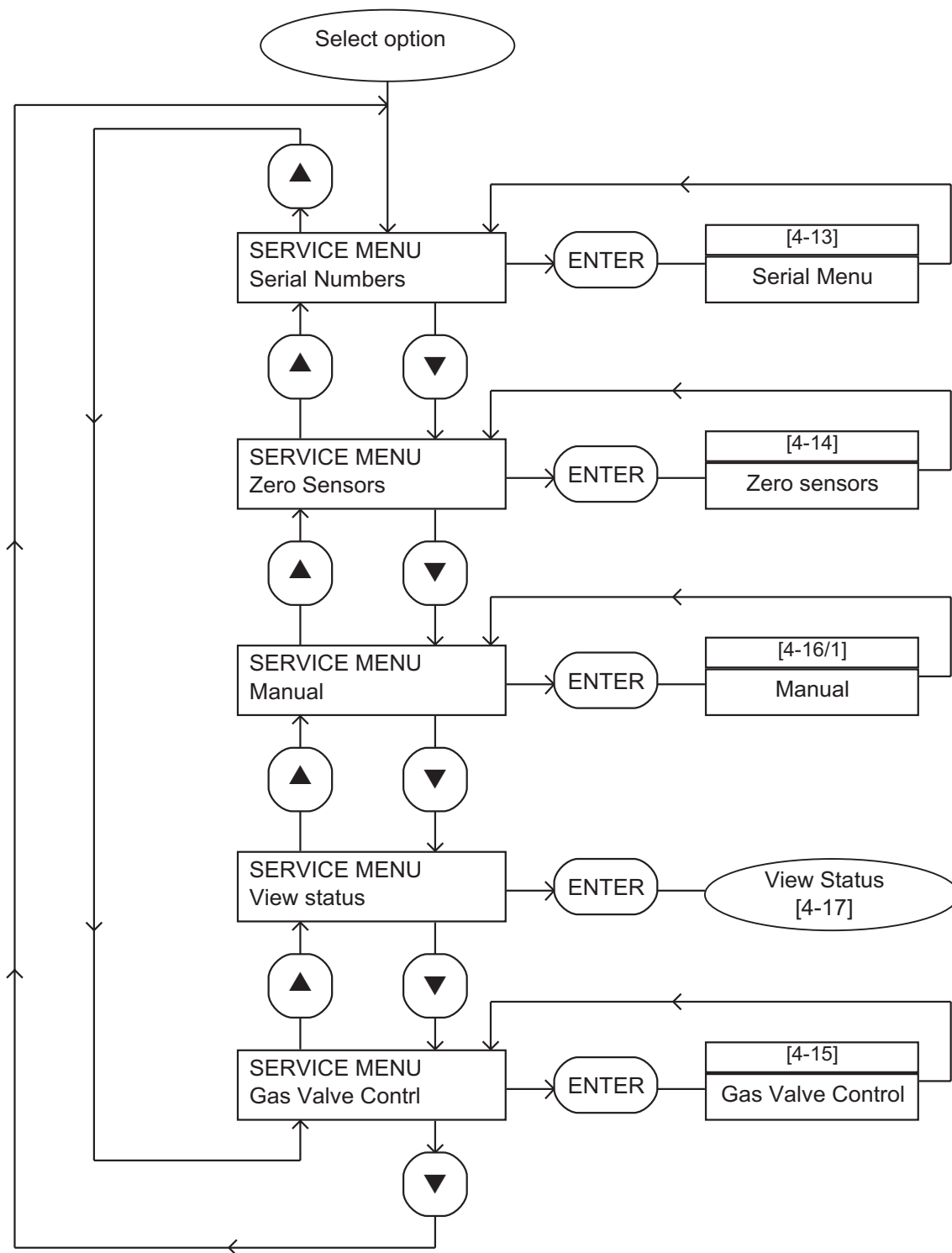

Figure 4-12 - Service menu: sheet 2 of 2

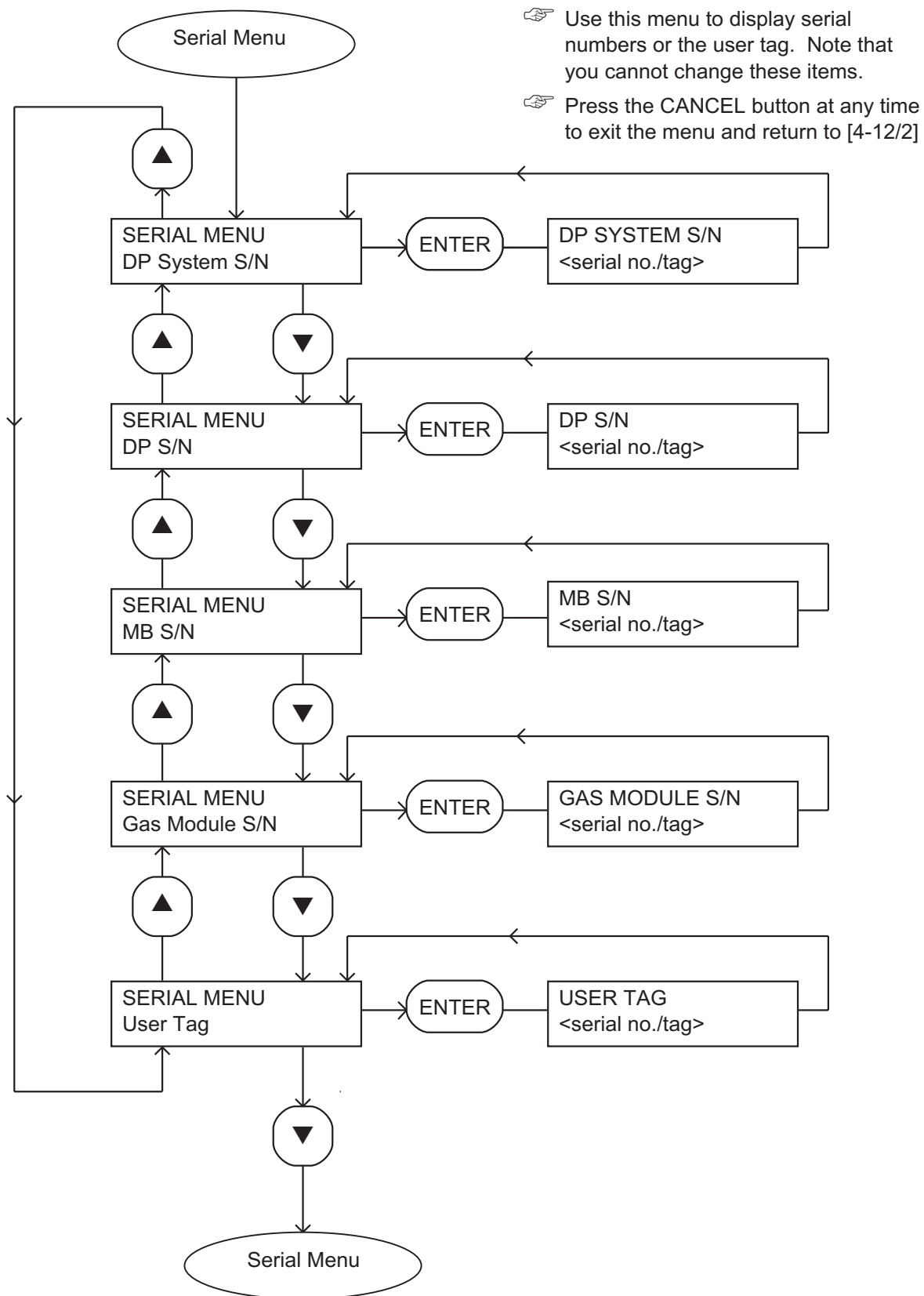

Figure 4-13 - Serial menu

Note: This menu is not used in the iL system: you can select the menu and press buttons as shown below, but menu actions will have no effect on iL system operation.

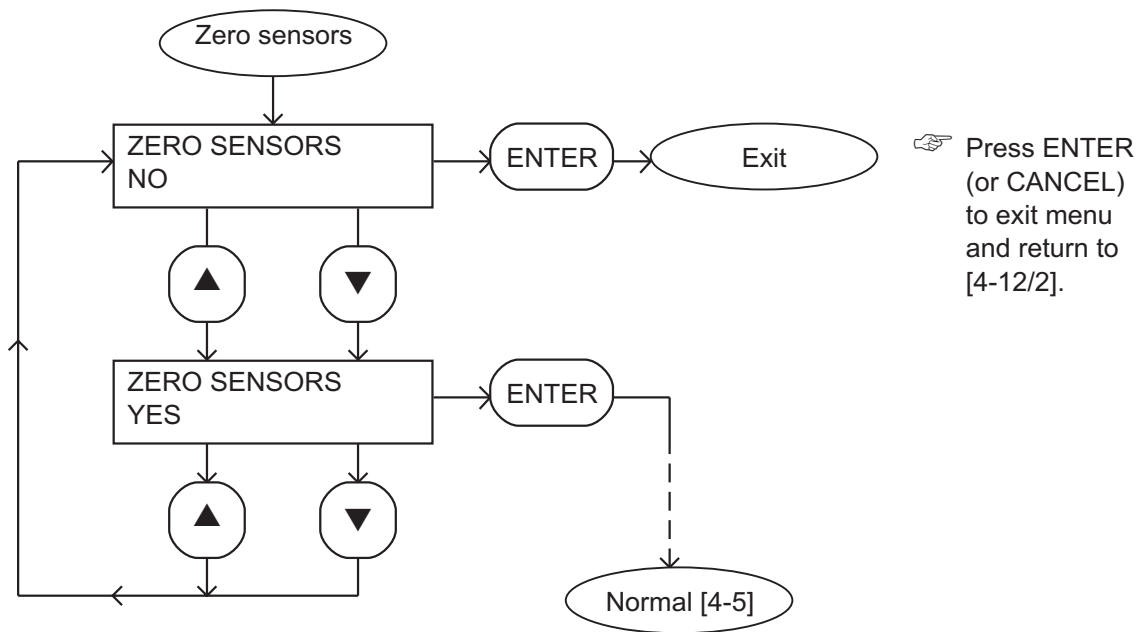

Figure 4-14 - Zero sensors menu

Note: This menu is not used in the iL system: you can select the menu and press buttons as shown below, but menu actions will have no effect on iL system operation.

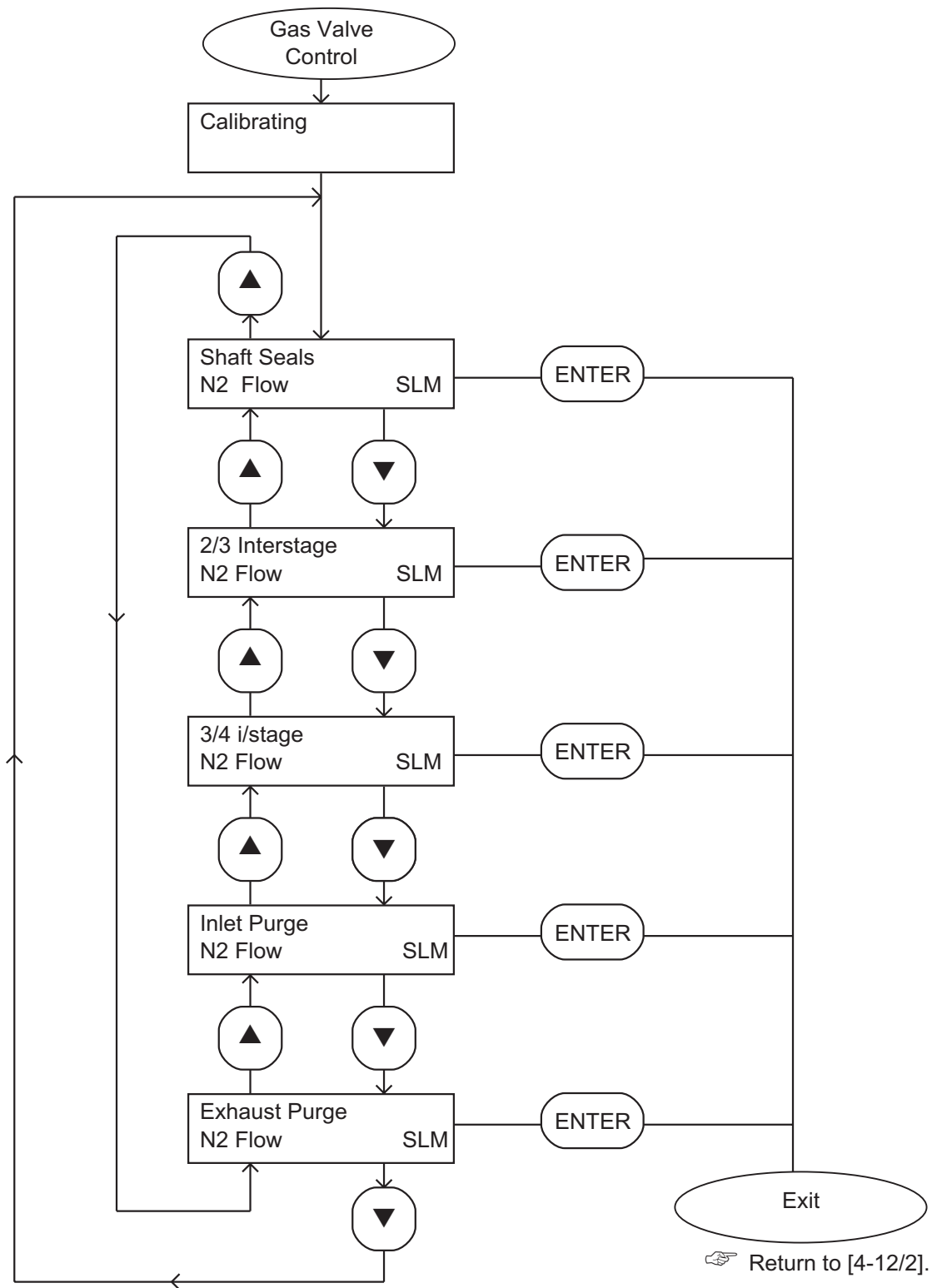

Figure 4-15 - Gas valve control menu

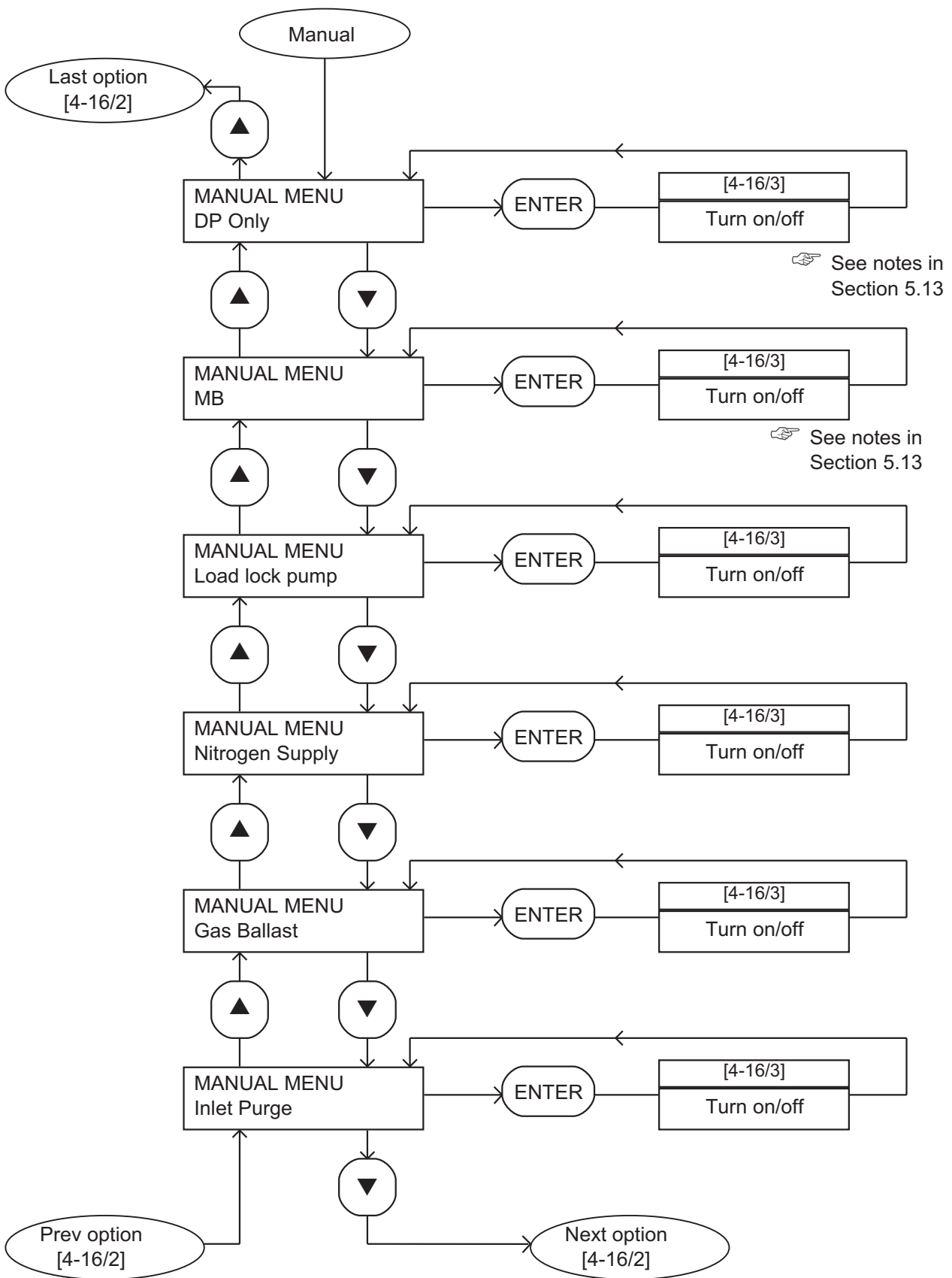

Figure 4-16 - Manual menu: sheet 1 of 3

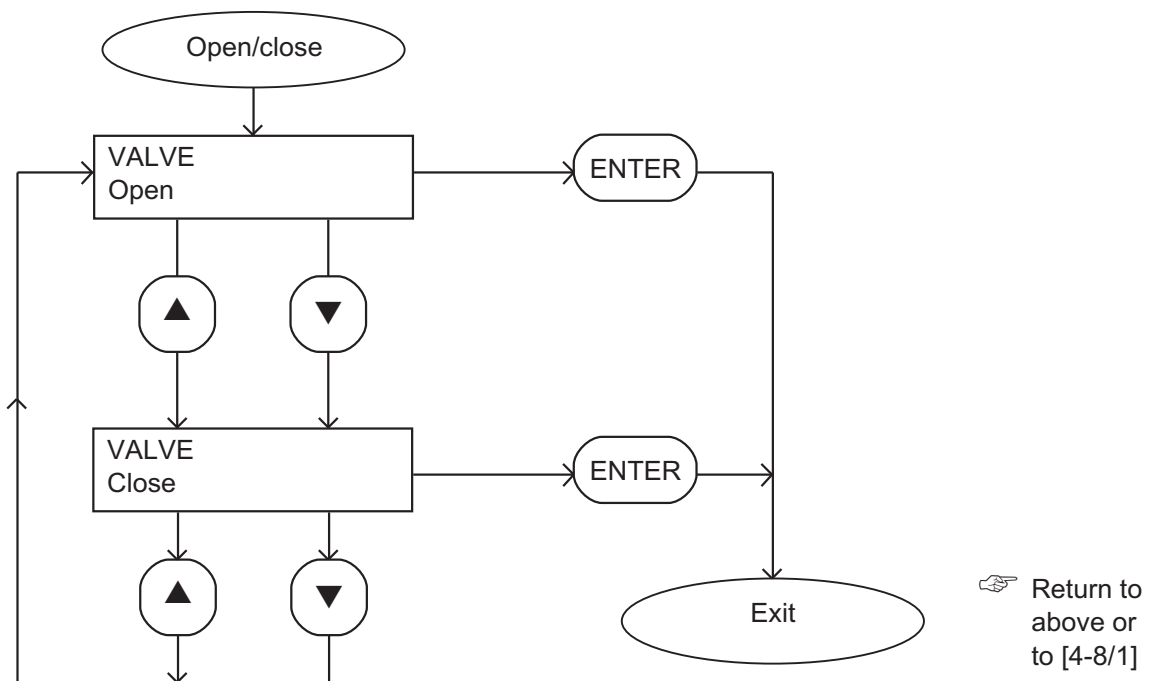
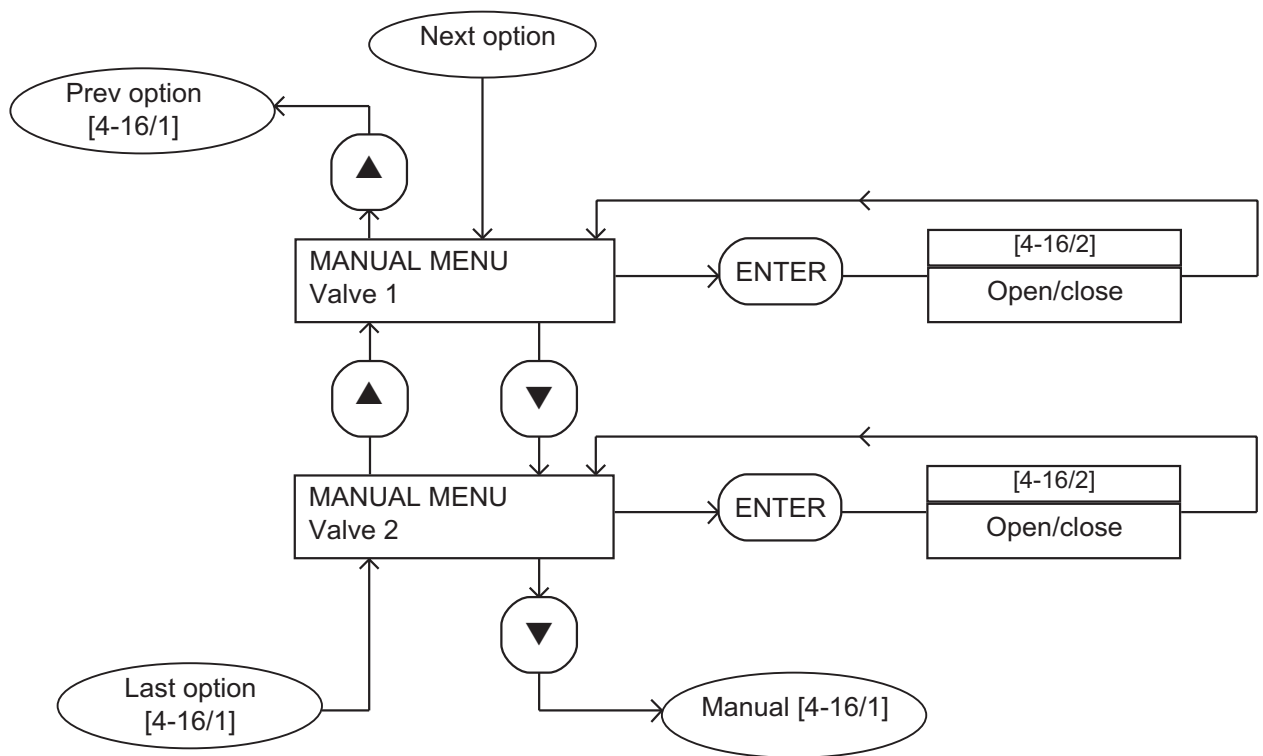

Figure 4-16 - Manual menu: sheet 2 of 3



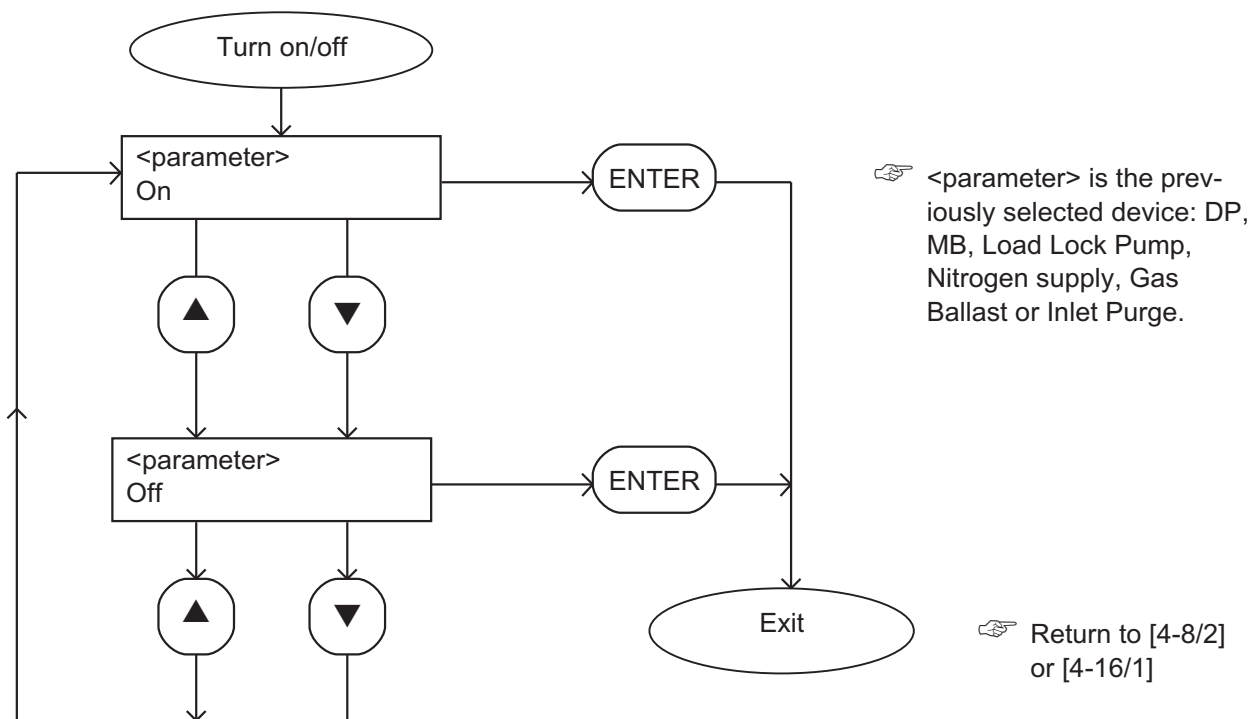

Figure 4-16 - Manual menu: sheet 3 of 3

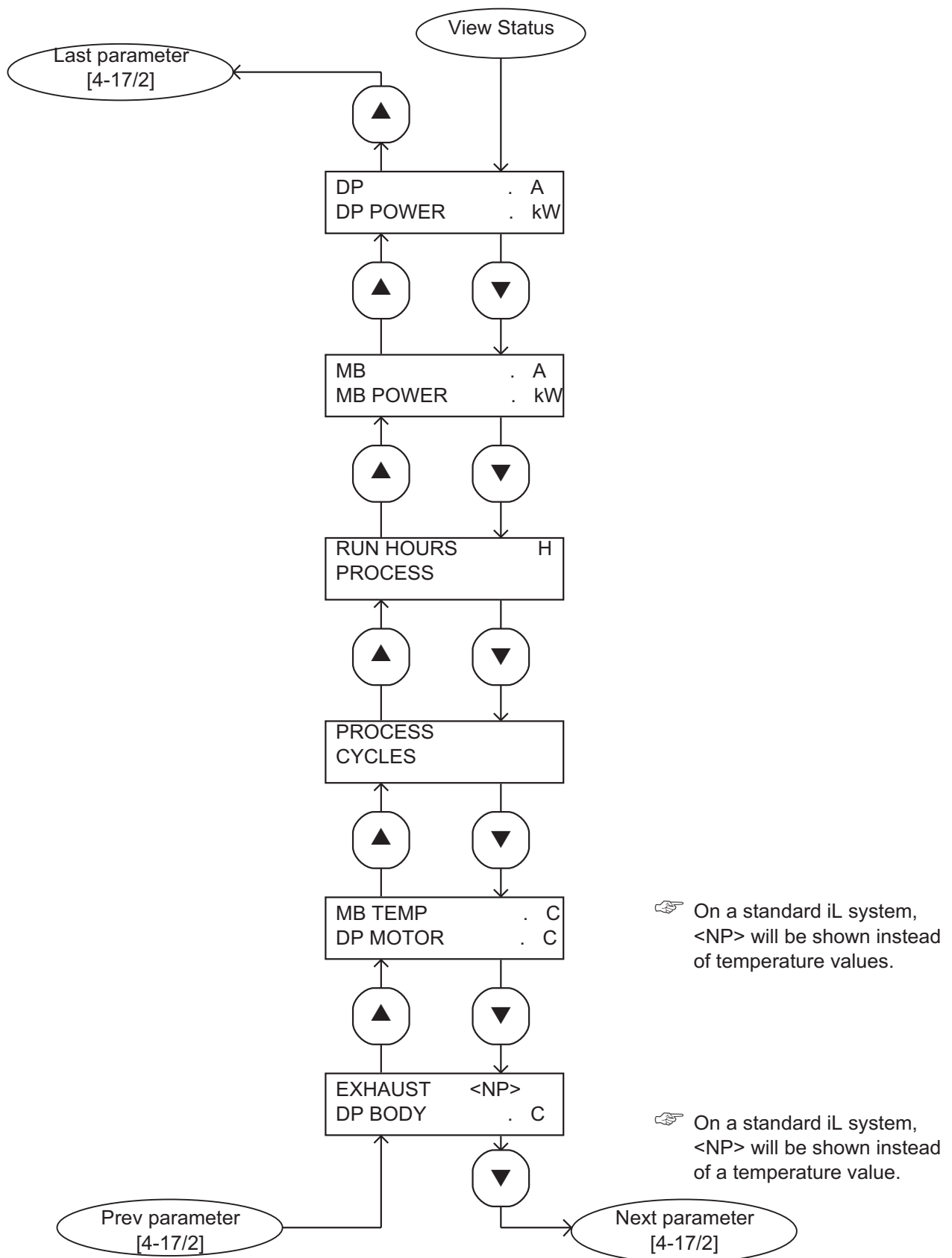

Figure 4-17 - View Status menu: sheet 1 of 2

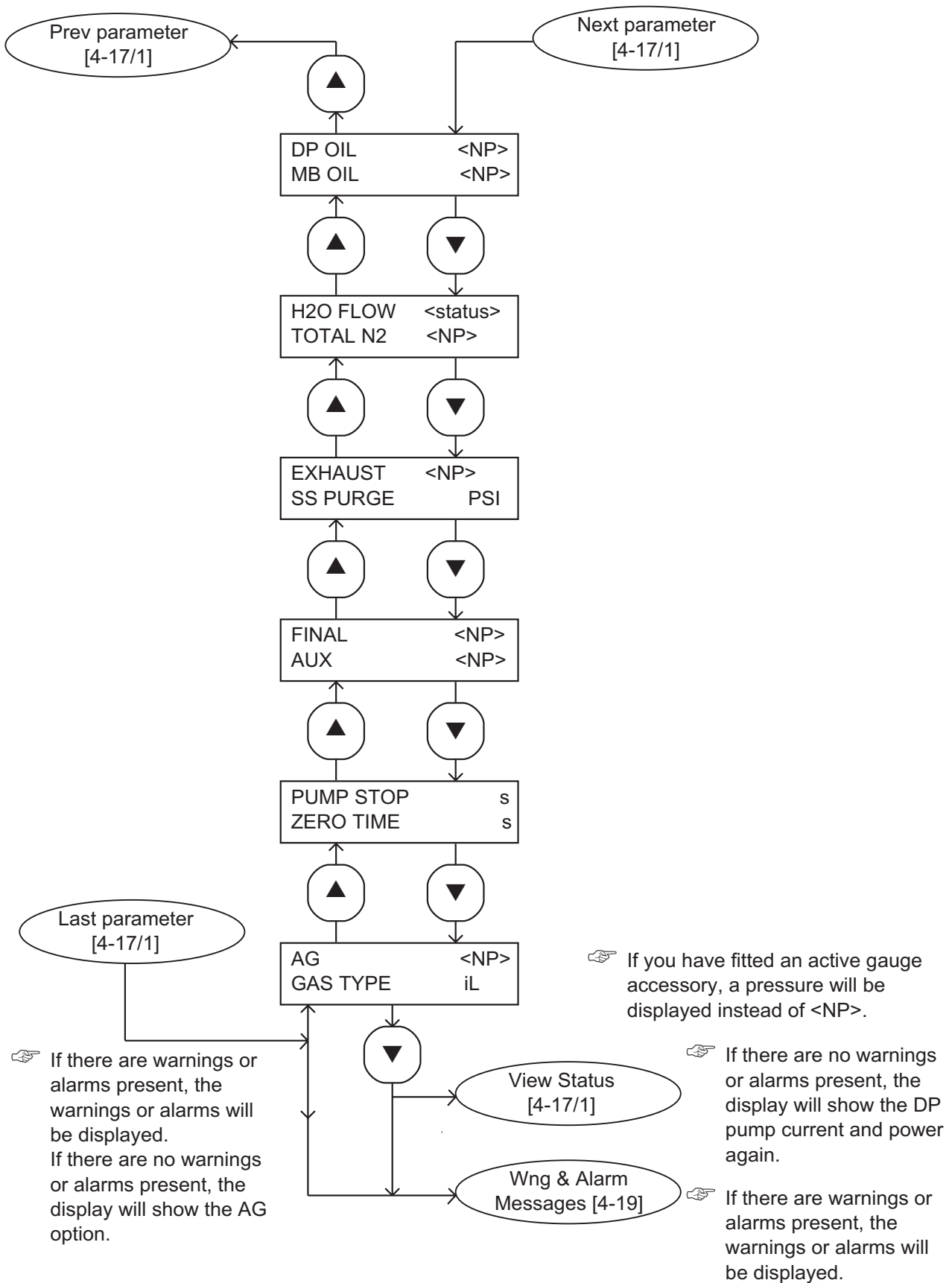

Figure 4-17 - View Status menu: sheet 2 of 2

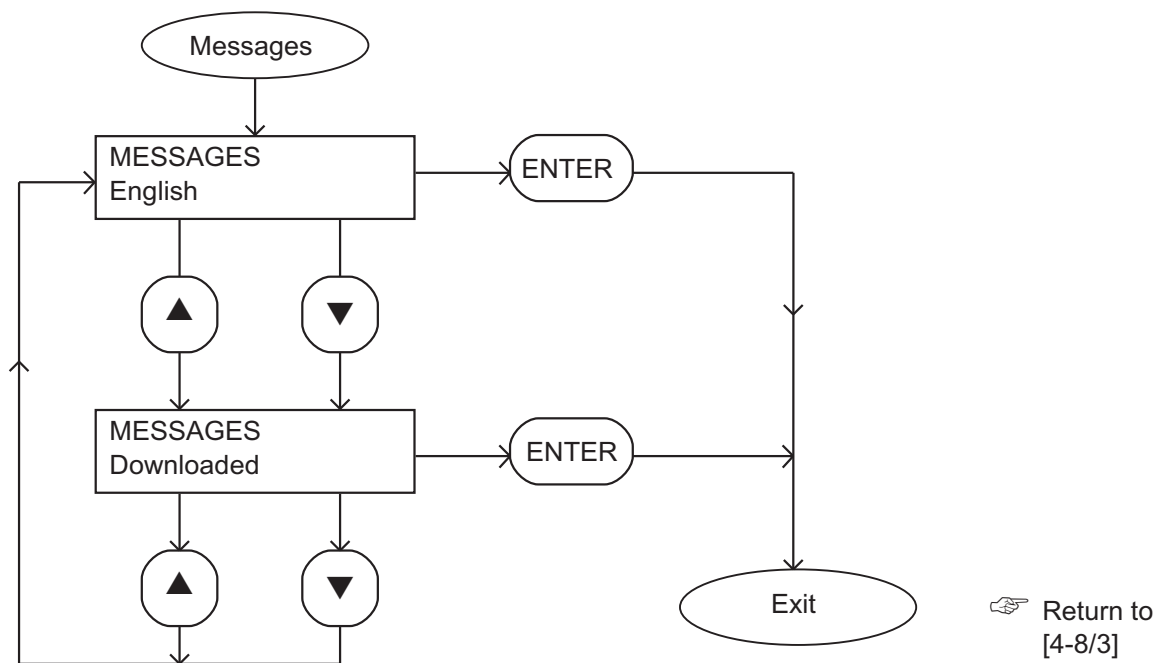

Figure 4-18 - Messages menu

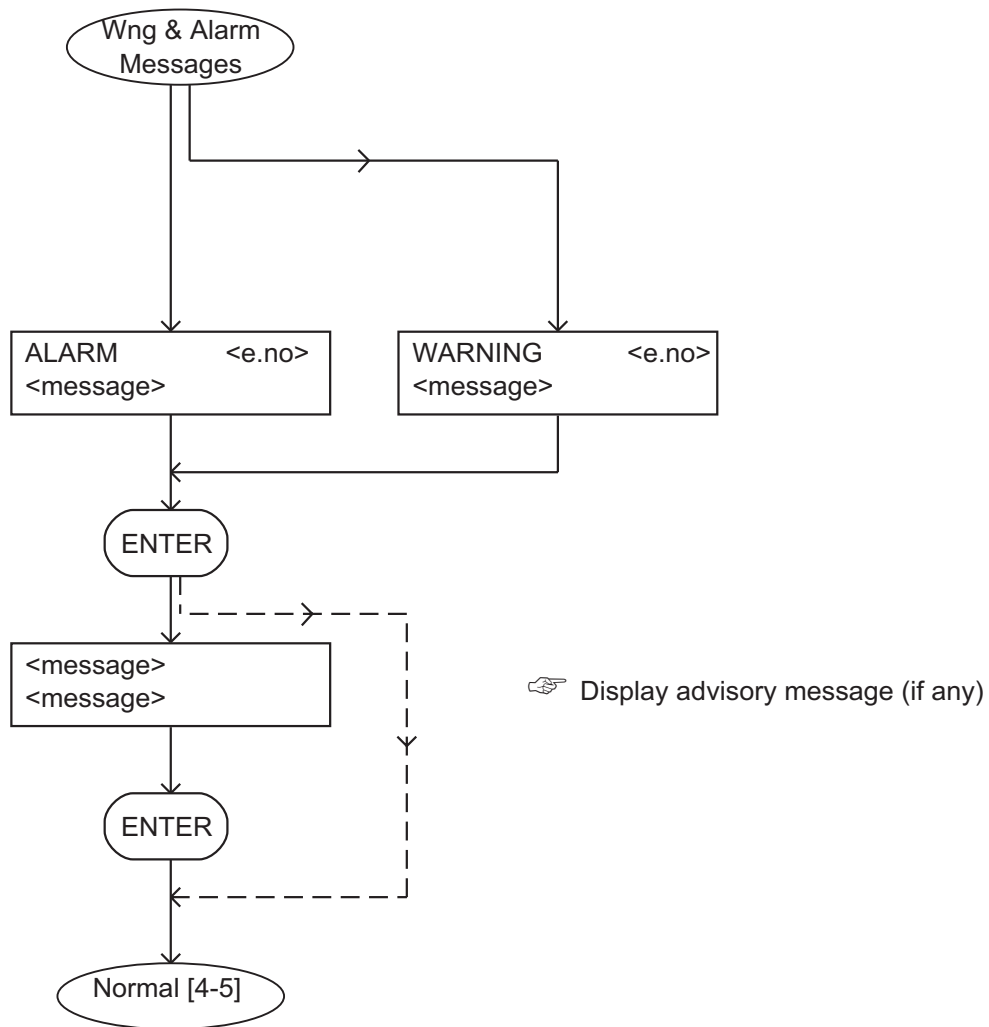

Figure 4-19 - Warning and alarm messages menu

## 5 OPERATION

### 5.1 Introduction

The following sections describe the use of the Pump Display Module to operate the iL system. For a description of the use of an Interface Module or Communications Module accessory to operate the iL system, refer to the instruction manual supplied with the Module. For a description of the operation of the load-lock pump (if you have connected the iL system to the load-lock pump through an Interface Module), refer to Section 5.14.

The following sections summarise the use of the menus in the Pump Display Module. We refer to menus such as 'the Setup/Service/Manual menu'. Refer to Figure 1-7 or 4-1: this means that you:

Press the Setup button (7) to select the Setup menu.

Use the up and down buttons (5, 3) to show the Service option and press ENTER (6) to select the Service menu.

Use the up and down buttons (5, 3) to show the Manual option and press ENTER (6) to select the Manual menu.

We recommend that you fully understand the use of the Pump Display Module menus and buttons before you operate the iL system. Refer to Section 4 which fully defines the menus, the use of the buttons and the display formats.

Note that you must switch on the electrical supply to the iL system before you can use the Pump Display Module.

### 5.2 Change the display format

#### 5.2.1 Change the normal display

During normal operation (or whenever the Normal menu is selected), the Pump Display Module will show the first page of the normal display. The normal display has two pages and each page can show the readings of one or more sensors or internal clocks or counters. As supplied, the information shown on the first page is:

LCDP pump power consumption

LCDP pump-body temperature

If you press the up or down button, the Pump Display Module will then show the second page of normal display; as supplied, the information shown on the second page is:

LCMB pump power consumption      (" $\langle$ NP $\rangle$ " shown for iL70 systems: see Section 4.4)

LCMB pump temperature

If required, you can use the Setup/Normal display menu to change the information shown on the two normal display pages.

## 5.2.2 Change the display units

If required, you can change the Pump Display Module display units:

Pressures shown on the Pump Display Module can be displayed in either kPa or psi. Use the Setup/Units/Pressure menu to change the pressure display units.

Temperatures shown on the Pump Display Module can be displayed in either °C or °F. Use the Setup/Units/Temperature menu to change the temperature display units.

Pressures measured by an optional Active Gauge connected to the iL system, can be shown on the Pump Display Module in either mbar, kPa or Torr. Use the Setup/Units/AG menu to change the Active Gauge pressure display units.

## 5.3 Take and release control

To use the Pump Display Module to control the operation of the iL system, the Local control LED on the Pump Display Module (Figure 1-7, item 9) must be on. If the LED is not on, use the Control menu to take control. You cannot take control with the PDM if another module already has control.

If you need to use another module (for example, the iL Interface Module) to operate the iL system, the Local control LED on the Pump Display Module (Figure 1-7, item 9) must be off. If the LED is on, use the Control menu to release control.

If you use the Pump Display Module to start up the iL system and you then disconnect the Module from the iL for 150 seconds or more, the iL system will automatically assume that the Pump Display Module has released control; you will then have to use one of the following methods to shut down the iL system:

Take control with the Pump Display Module again, then shut down the iL system as described in Section 5.8.

Take control with another module and use that module to shut down the iL system.

Use the emergency stop switch, as described in Section 5.10.

## 5.4 Start-up

### WARNING

Do not operate the iL system with any enclosure panels removed and do not touch any parts of the pump(s) when the iL system is on. Surfaces of the pump(s) are very hot and can cause injury to people.

### WARNING

Ensure that it is safe to start the iL system. If you do not (and, for example, maintenance is being performed on components downstream of the iL system), you could cause injury to people.

*Note:* When you use the Pump Display Module to start up the iL system, we recommend that you do not disconnect the Module from the iL system; if you do, you will not be able to use the Module to instantly shut down the iL system: see Section 5.3.

1. Switch on the cooling-water supply, the nitrogen supply on sensor configured systems, and the external electrical supply (if not already on).
2. Ensure that the exhaust-extraction system is not blocked and that valves in the exhaust-extraction system are open.
3. Ensure that the Pump Display Module has control of the iL system: refer to Section 5.3.
4. Refer to Figure 1-7. Look at the display (2) on the Pump Display Module:

If there are any warnings or alarms, take the necessary corrective action (refer to Section 6); do not start the iL system.

If there are no alarms or warnings displayed, use the Switch On menu to switch on the iL system.

When you switch on, the following actions will occur (with a small time delay between each action):

The LED on the On button on the Pump Display Module will start to flash.

The LCDP pump will be switched on.

The LED on the On button on the Pump Display Module will stay permanently on.

The solenoid valve in the Gas Module will open to switch on the nitrogen supply to the LCDP pump.

On iL600 systems, after the booster start delay, the LCMB pump will be switched on.



## 5.5 Check the nitrogen pressure and adjust if necessary (sensor-configured iL systems only)

*Note: You must only check and adjust the nitrogen pressure after the iL system has been operating for at least four hours, so that the LCDP pump is at its correct operating temperature.*

You **must** check and adjust the nitrogen pressure when you first use the iL system. Thereafter, we recommend that you regularly check and adjust the nitrogen pressure, to ensure optimum shaft-seals performance and to maximise the life of the shaft-seals.

When you need to adjust the nitrogen pressure:

Turn the pressure regulator clockwise to increase the pressure.

Turn the pressure regulator anticlockwise to decrease the pressure.

Use the following procedure to check and adjust the nitrogen pressure:

1. Refer to Figure 1-6. Pull up the top of the pressure regulator (3) to unlock it.
2. Adjust the pressure regulator (3) until the pressure high and pressure low LEDs (4, 5) are both on. Alternatively, use the Status/SS purge menu to display the nitrogen flow, and adjust the pressure regulator (3) until a pressure of 4.0 psig (27.5 kPa) is displayed.
3. Push down the top of the pressure regulator (3) to lock it.

## 5.6 Monitor the status of the iL system

*Notes: If you have selected the Status menu and then do not press any button for five minutes, the display will change to the Normal display: refer to Section 5.2.*

*You can select additional options not shown in Table 5-1, but these will be shown as "NP" (not present): see Section 4.4.*

Use the Status menu or the Setup/Service/View Status menu to display the values of internal clocks and counters. The information that can be displayed (up to two items of information at a time) is shown in Table 5-1.

Sensor data	Units	Notes
LCDP pump current consumption	A	
LCDP pump power consumption	kW	
LCMB pump current consumption *	A	
LCMB pump power consumption *	kW	
Total running time	hours	Total run-time of the iL system.
Process running time †	hours	Total run-time on process.
Process cycles †	-	Process cycles.
iL cycles	-	The number of times the iL system has been switched on/off.
LCMB pump temperature *▼	°C/°F	
LCDP pump-motor water manifold surface temperature ▼	°C/°F	
LCDP pump body temperature ▼	°C/°F	
LCDP pump oil-level ▲▼	-	OK indicates the oil-level is acceptable; CHECK indicates that the oil-level is too low, or that the oil monitor is faulty or disconnected: see Section 6.
LCMB pump oil-level *▲▼	-	As LCDP oil-level: see above.
Water flow ▼	-	OK indicates the cooling-water flow is acceptable; CHECK indicates that the flow is too low, or that the water flow-switch is faulty or disconnected: see Section 6.
Shaft-seals purge pressure ▼	kPa/psi	
Pump stop time	seconds	Time remaining until the pump stops, during a fast manual shut down.
Pump zero time	seconds	Not applicable to the iL system
Active gauge pressure ▲	mbar/kPa/Torr	
Warning/alarm messages #	-	Refer to Section 6 for a list of the messages.

▼ Sensor-configured iL systems only.

\* iL600 only.

† These display items require signals from the process tool to indicate when the process is on and off, hence these items are only available if you have an iL Interface Module.

▲ Only available for display if the appropriate optional accessory is fitted to the iL system.

# These messages cannot be manually selected to be displayed on the Normal display, but will be automatically displayed on the Normal display when a warning or alarm condition exists.

Table 5-1 - Status menu display options

## 5.7 Warning and alarm indications

*Notes: Refer to Section 6 for a full list of the warning and alarm messages and their meanings.*

If a warning or alarm condition exists:

The top line of the display on the Pump Display Module will change to 'WARNING' or 'ALARM', together with an error number.

The bottom line of the display will show the warning or alarm message or (for some errors) will be blank.

The warning or alarm LED on the Pump Display Module will flash.

To acknowledge the warning or alarm, press the ENTER button. If the warning or alarm condition has cleared, the warning or alarm LED will go off. If the warning or alarm condition is still present:

The warning or alarm LED will stay on.

If the warning or alarm condition does not have an advisory message (see Section 6.14), the display will then change to normal display: see Section 5.2.

If the warning or alarm condition has an advisory message (see Section 6.14), the display will show two lines which describe a simple check which you can make to identify the cause of the fault and to rectify the fault. When you have read the message, press the ENTER button again; the display will then change to normal display: see Section 5.2.

## 5.8 Manual shut-down

### WARNING

If you intend to do any maintenance on the iL system which does not require the system to be isolated from the electrical supply after you have shut it down, do not disconnect the Pump Display Module or release control from the Pump Display Module (see Section 5.3).  
If you do, the iL system could be started by another Module.

*Note: Press the Cancel button on the Pump Display Module to cancel a shut-down request.*

Use one of the methods described in Sections 5.8.1 and 5.8.2 to manually shut down the iL system. Ensure that it is safe to shut down the iL system before you select shut-down.

### 5.8.1 Normal manual shut-down

*Note: The purge time for the normal manual shut-down option is preset to 15 minutes as supplied. This purge time can be configured for your application.*

We recommend that you use the Switch Off/ Auto menu to shut down the iL system in normal operating conditions. This method provides a 15 minute period after shut-down selection during which you can purge the foreline.

When you select this shut-down option, the following actions will occur (with a small time delay between each action):

On an iL600 system, the LCMB pump is switched off.

The LED on the On button on the Pump Display Module (Figure 1-7, item 1) starts to flash.

On a sensor-configured iL system, the iL system is left to operate for 15 minutes with shaft-seals purge switched on; after 15 minutes, the gas solenoid-valve is closed to switch off shaft-seals purge.

After approximately 15 minutes, the LCDP pump is switched off.

The LED on the On button on the Pump Display Module goes off.

## 5.8.2 Fast manual shut-down

Use the Switch Off/Fast menu to shut down the iL system quickly. When you select this shut-down option, the following actions will occur (with a small time delay between each action):

On an iL600 system, the LCMB pump is switched off.

The LED on the On button on the Pump Display Module (Figure 1-7, item 1) starts to flash.

On a sensor -configured iL system after approximately 15 seconds, the gas solenoid-valve is closed to switch off shaft-seals purge to the LCDP pump, and at the same time the LCDP pump is switched off.

The LED on the On button on the Pump Display Module goes off.

## 5.9 Automatic shut-down

### CAUTION

If you select 'Run til crash', the pump can be damaged and you may invalidate any warranties on the iL system equipment.

*Note: The emergency stop button, the emergency stop signal from your control equipment (if fitted) and the safety sensors (see Section 1.10.3) will still shut down the iL system, even if you have selected 'Run til crash'.*

Normally, if an alarm condition exists, the Electrics and Pump Control Module will shut-down the iL system automatically. When automatic shut-down is initiated, the following actions will occur (with a small time delay between each action):

On an iL600 system, the LCMB pump is switched off.

The LED on the On button on the Pump Display Module (Figure 1-7, item 1) starts to flash.

On a sensor -configured iL system after approximately 15 seconds, the gas solenoid-valve is closed to switch off shaft-seals purge to the LCDP pump, and at the same time the LCDP pump is switched off.

The LED on the On button on the Pump Display Module goes off.

If required, you can request 'run til crash' operation. In this mode of operation, most alarm conditions will be ignored and the iL system will continue to operate. Note however that for safety reasons the following alarms will shut down the iL system even if you have selected 'run til crash':

LCDP CURRENT HIGH/LOW (error numbers 310 and 312).

LCDP THERMISTOR HIGH (error number 512).

On an iL600 system, the following alarms will cause only the LCMB pump to shut down, provided 'run til crash' is not selected:

LCMB POWER HIGH/LOW (error numbers 810 and 812).

LCMB PHASE IMBALANCE (error number 1012).

On an iL600 system, the following alarms will cause only the LCMB pump to shut down, whether 'run til crash' is selected or not:

LCMB CURRENT HIGH/LOW (error numbers 710 and 712).

LCMB THERMISTOR HIGH (error number 912).

Use the Setup/Run Til Crash menu to select 'run til crash'.

## 5.10 Emergency stop

*Notes: The emergency stop switch is not an electrical isolator.*

*The use of emergency stop will not automatically shut down the load lock pump (if fitted); you must shut down the load lock pump separately.*

To shut down the iL system in an emergency, press the emergency stop switch on the front panel (Figure 1-6, item 1). Alternatively, you can operate the emergency stop controls in your own control system if you have connected your emergency stop circuit to the iL system as described in Section 3.15. When emergency stop is selected:

The LCDP pump (and the LCMB pump, on iL600 systems) is switched off.

On a sensor -configured iL systems the solenoid valve in the gas module closes to switch off the supply of nitrogen to LCDP pump.

The Pump Display Module will display 'STOP ACTIVATED'.

The LED on the On button on the Pump Display Module (Figure 1-7, item 1) will go off.

## 5.11 Restart the LCMB pump after automatic pump shut-down (iL600 only)

If the LCMB pump has been automatically shut down due to an alarm (see Section 5.9), use the Switch On/Booster Pump menu to restart the LCMB pump after the alarm condition has cleared.

## 5.12 Restart the iL system after emergency stop or automatic shut-down

*Note:* If the iL system has automatically shut down because of high LCDP pump power (alarms 412 and 512), check that the LCDP pump is free to rotate before you restart the iL system: refer to Section 6.15.

If you have used the emergency stop switch on the front panel to shut down the iL system, you must reset the emergency stop switch before you can restart the iL system. Turn the emergency stop switch to reset it, then restart the iL system as described in Section 5.4. Note that the 'STOP ACTIVATED' alarm message (see Table 6-2) may stay on the Pump Display Module until you restart the pumping system.

If the iL system has been automatically shut down because of an alarm condition, the alarm condition must be rectified before you can restart the iL system. For example, if the iL system has been shut down because the LCDP pump-motor is too hot, the pump-motor must be allowed to cool before you can restart the iL system. Restart the iL system as described in Section 5.4.

## 5.13 Operation of iL system components

### WARNING

Ensure that it is safe to start the iL system. If you do not (and, for example, maintenance is being performed on components downstream of the iL system), you could cause injury to people.

### CAUTION

On an iL600 system, do not operate the LCMB pump unless the LCDP pump is on and has been operating for longer than the booster start delay. If you do, you may damage the iL system.

### CAUTION

Ensure that you do not over-pressurise the vacuum system if you switch on purge gas flow when the pumps are not on.

*Notes:* The gate valves must be connected to the iL system through an iL Interface Module with an Auxiliary Interface Card.

*When you use the Setup/Service/Manual menu to manually start the LCDP pump or (on an iL600 system) the LCMB pump, the pump will only operate for 10 seconds and will then automatically be switched off again.*

*Although you can select and use the Setup/Service/Manual/MB menu, this will have no effect on the LCMB pump; that is, you cannot use the menu to manually switch the LCMB pump on and off.*

In normal operating conditions, the components of the iL system are operated automatically.

If necessary (for example, for fault finding purposes), you can control the operation of iL system components separately:

Use the Setup/Service/Manual/Valve menu to control the operation of the gate valves (that is open or close the valves).

Use the Setup/Service/Manual/DP Only menu to control the operation of the LCDP pump (that is, switch the LCDP pump on and off).

## **5.14 Operation of the load-lock pump**

If you have connected a load-lock pump to the iL system through an Interface Module, you can use the following menus to control the operation of the load-lock pump:

Switch On.

Switch Off.

Setup/Service/Manual/Load lock pump.

## 6 MAINTENANCE

### 6.1 Safety

#### 6.1.1 General requirements

##### WARNING

Obey the safety instructions given below and take note of appropriate precautions. If you do not, you can cause injury to people and damage to equipment.

A suitably trained and supervised technician must maintain the iL system.

Ensure that the maintenance technician is familiar with the safety procedures which relate to the products pumped. Wear the appropriate safety-clothing when you come into contact with contaminated components. Dismantle and clean contaminated components and drain oil inside a fume-cupboard.

Allow the pump to cool to a safe temperature before you start maintenance work.

Vent and purge the iL system with nitrogen before you start any maintenance work: refer to Section 6.1.2.

Isolate the iL system and other components in the process system from the electrical supply so that they can not be operated accidentally. Note that the emergency stop switch on the iL system is **not** an electrical isolator. (Note however that you must operate the iL system to purge the pump: refer to Section 6.1.2).

Recheck the pump rotation direction if the electrical supply has been disconnected.

'O' ring replacement intervals vary depending on your application - your local BOCE office can provide assistance.

Do not reuse 'O' rings.

Dispose of components, grease and oil safely (see Section 7.2).

Take care to protect sealing-faces from damage.

Do not touch or inhale the thermal breakdown products of fluorinated materials which may be present if the iL system has been overheated to 260 °C and above. These breakdown products are very dangerous. Fluorinated materials in the iL system may include oils, greases, seals and rotor coatings. The iL system may have overheated if it was misused, if it malfunctioned or if it was in a fire. BOC Edwards Material Safety Data Sheets for fluorinated materials used in the iL system are available on request: contact your supplier or BOC Edwards.

Leak-test the system after maintenance work is complete if you have connected or disconnected any vacuum or exhaust joints; seal any leaks found.



## 6.1.2 Recommended purge method

*Note: To use the following procedure to purge the iL system, you must be able to introduce nitrogen purge gas into the foreline without disconnecting any of the vacuum connections.*

We recommend that you purge the iL system as described below before you do maintenance. You **must** use this purge procedure if you have pumped dangerous substances, or if you think that fluorinated materials in the pump may have overheated and undergone thermal breakdown. This method of purge allows you to reduce the concentration of process gases in the pump gearbox(es).

1. Close any valves between the pump foreline and the process chamber and leave the iL system open to the foreline.
2. Start the LCDP pump (and on iL600 systems, the LCMB pump) and leave the iL system to operate for five minutes.
3. Shut down the iL system and leave it shut down for at least five minutes, to allow the pressures in the pump and gearbox to equalise.
4. With the LCDP pump (and on iL600 systems, the LCMB pump) stopped, purge the foreline with nitrogen up to a pressure of 1 bar ( $1 \times 10^5$  Pa) for five minutes.
5. The concentration of process gas in the gearbox(es) will then have been reduced by a factor of  $4/V_f$ , where  $V_f$  is the volume of the foreline in litres.

### Example

Suppose the foreline between the iL system and the tool isolation valve is made up of 10m of ISO63 pipe. This foreline has an approximate volume of 30 litres.

To assume the worst case, suppose the initial concentration of process gases in the gearbox is 100%. After the first iteration of the purge procedure the concentration would be reduced to:  $4/30 * 100 = 13\%$ .

If the acceptable level of contamination is 100ppm five iterations will be sufficient to achieve a safe level. After five iterations the concentration of process gas in the pump system would be:  $(4/30)^5 * 100 = 0.004\% = 42\text{ppm}$ .

6. Repeat this procedure from Step 2 again until a safe concentration has been reached.

## 6.2 Correct use of Swagelok connectors

*Note: We recommend that you use a second spanner to hold the connector in position when you connect or disconnect a Swagelok connector.*

### 6.2.1 Fit the Swagelok connector

You must know how to correctly fit and tighten Swagelok connectors in order to prevent gas leaks. Use the following procedure to fit the Swagelok connector:

(Continued on page 6-4)

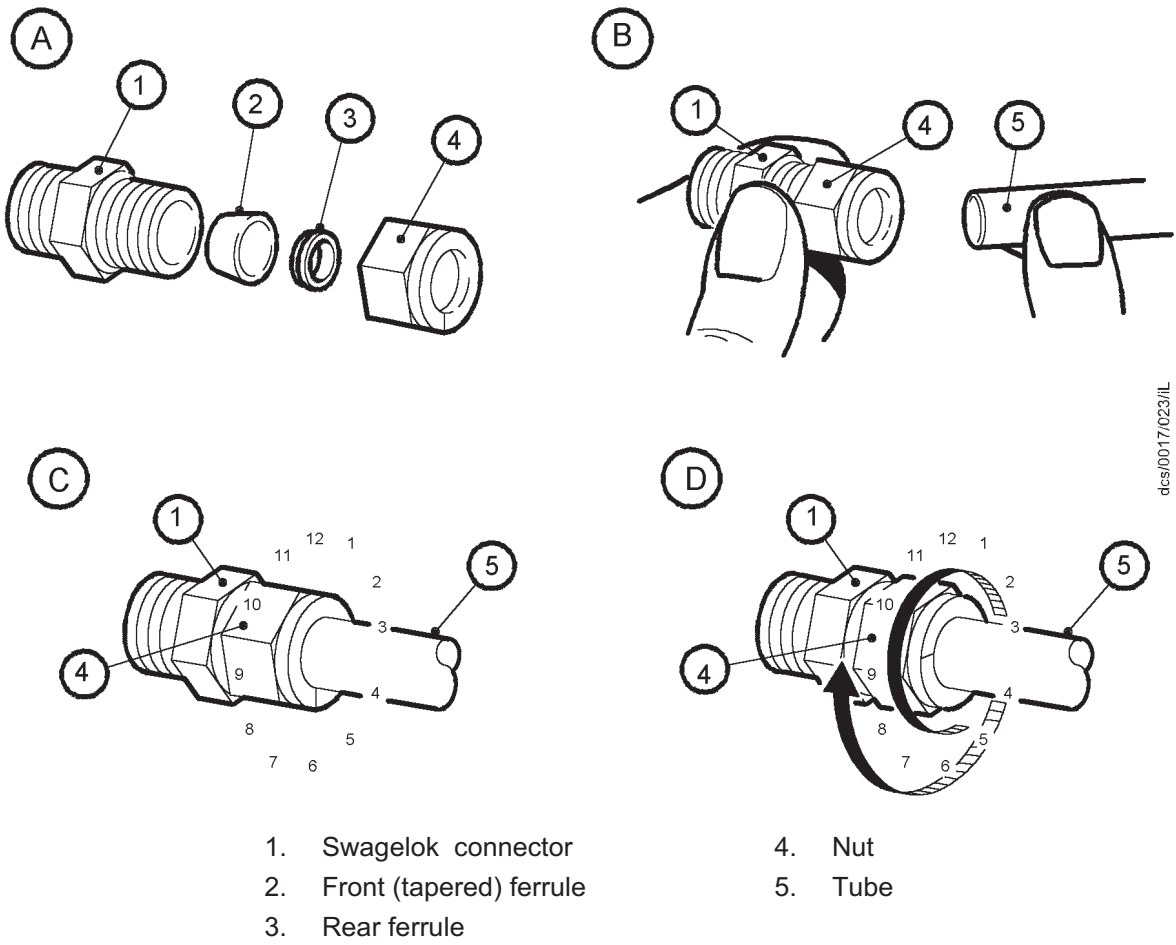

Figure 6-1 - Fit a Swagelok fitting

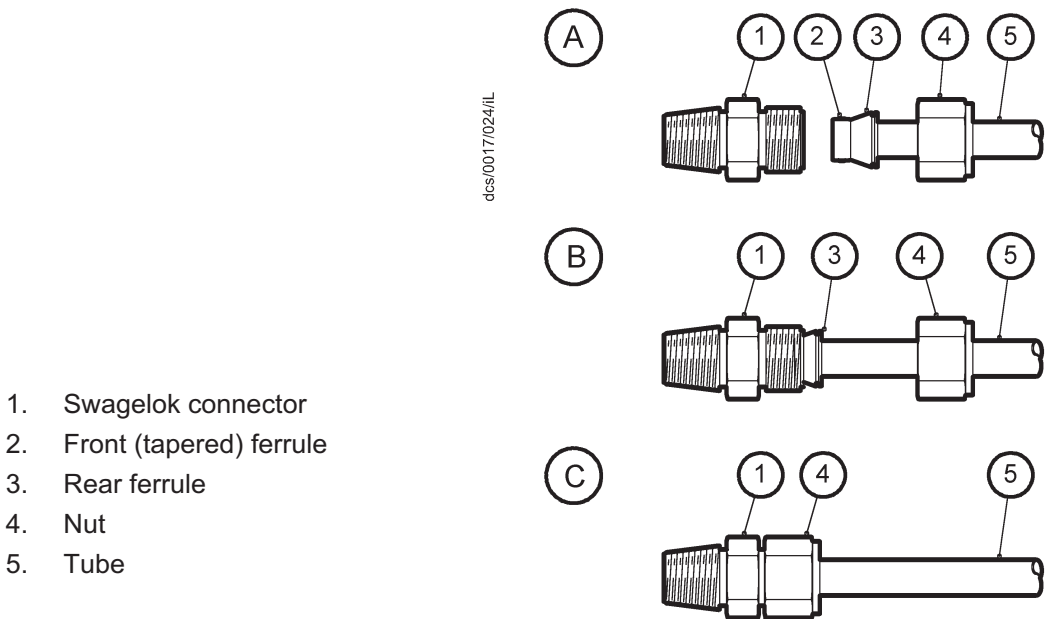

Figure 6-2 - Retighten a Swagelok fitting

1. Refer to Figure 6-1 detail B. Insert the tube (5) through the nut (4) and into the Swagelok connector (1). Ensure that the tube rests firmly on the shoulder inside the fitting, and that the nut (4) is finger tight.
2. Tighten the nut (4) until you cannot rotate the tube (5). If you cannot turn the tube because of how it is installed, tighten the nut by  $\frac{1}{8}$ th of a turn.
3. Refer to detail C. Mark the nut (4) at the six o'clock position.
4. Refer to detail D. Hold the body of the connector steady, then turn the nut (4) by  $1\frac{1}{4}$  turns (to the nine o'clock position) to fully tighten the connection.

### 6.2.2 Reconnect a Swagelok connector

You can disconnect and reconnect a Swagelok connector many times and still obtain a correct leak-proof seal. Refer to Figure 6-2 detail A which shows a Swagelok connector after you have disconnected it. Use the following procedure to reconnect it:

1. Refer to detail B. Insert the tube (5) with the swaged ferrules (2, 3) into the Swagelok fitting (1), until the front ferrule (2) is fully in the body of the fitting.
2. Refer to detail C. Tighten the nut (4) by hand.
3. Use a wrench or spanner to turn the nut (4) to its original position (you will feel an increase in resistance when the nut is in its original position), then tighten the nut slightly.

### 6.3 Maintenance frequency

The iL system requires little user maintenance. The maintenance operations you can carry out are described in the following sections. The frequency of maintenance operations depends on your process. Adjust the frequency of maintenance operations according to your experience.

When you maintain the iL system, use BOC Edwards maintenance and service kits. These contain all of the necessary seals and other components necessary to complete maintenance operations successfully.

### 6.4 Inspect the connections, pipelines, cables and fittings

*Note: Refer to Section 6.2 if you have to connect, disconnect or tighten Swagelok fittings.*

1. Remove the enclosure side and top panels: refer to Section 3.4.
2. Check that all the cooling-water connections are secure; tighten any loose connections. Inspect all cooling-water pipelines, hoses and connections and check that they are not corroded or damaged and do not leak; repair or replace any pipelines, hoses and connections that are corroded or damaged, or which leak.
3. Check that all the nitrogen connections are secure; tighten any loose connections. Inspect all nitrogen pipelines and connections and check that they are not corroded or damaged and do not leak; repair or replace any pipelines and connections that are corroded or damaged, or which leak.

4. Check that all electrical connections are secure; tighten any loose connections. Inspect all electrical cables and connectors for damage; replace any cables and connectors that are damaged.
5. Check that all process and exhaust connections are secure; tighten any loose connections. Inspect all process and exhaust pipelines and fittings and check that they are not corroded or damaged; replace any pipelines or fittings that are corroded or damaged.
6. Refit the enclosure side and top panels: refer to Section 3.17.

## 6.5 Inspect and clean the exhaust-pipe and check-valve

### WARNING

The substances which accumulate in the exhaust-pipe and check-valve can be dangerous. Do not allow these substances to come into contact with your skin or eyes. Do not inhale vapours from these substances. Fit blanking caps to the inlet and outlet flanges when you move the exhaust-pipe or check-valve around your workplace.

### 6.5.1 Dismantle, clean and refit the exhaust-pipe

Use the following procedure to dismantle, clean and refit the exhaust-pipe and elbow.

1. Refer to Figure 1-1. Remove the NW40 clamp and trapped 'O' ring on the outlet flange of the check-valve (17) to disconnect the iL system from your exhaust-extraction pipeline. Dispose of the trapped 'O' ring.
2. Remove the NW40 clamp and trapped 'O' ring which secures the check-valve (17) to the exhaust-pipe (18) and remove the check-valve (17). Dispose of the trapped 'O' ring.
3. Inspect the exhaust-pipe (18). If you do not need to remove the exhaust-pipe from the pump to clean it, continue at Step 12. If you need to remove the exhaust-pipe from the pump to clean it, continue at Step 4.
4. Undo and remove the bolt which secures the bracket on the exhaust pipe to the iL system.
5. Use a hexagonal key to remove the four M8 cap-head screws and washers which secure the flange on the exhaust-pipe (18) to the LCDP pump-outlet, then remove the metal 'O' ring and exhaust-pipe (18) from the LCDP pump. Dispose of the metal 'O' ring.
6. Empty all loose deposits from the exhaust-pipe (18), then use a suitable tool (for example, a long bottle-brush) and a cleaning solution suitable for the deposits to clean the exhaust-pipe.
7. Check that the mating surfaces of the LCDP pump outlet and the flange on the exhaust-pipe (18) are not scratched or damaged: if necessary refinish the surfaces.
8. Fit a new metal 'O' ring (available as a spare: refer to Section 8.3) to the 'O' ring groove on the flange on the exhaust-pipe (18).
9. Use the screws and washers (retained in Step 5) to secure the flange to the LCDP pump-outlet and tighten by hand; ensure that the 'O' ring remains correctly in place.
10. Use an hexagonal key to alternately and evenly tighten the four screws to a torque of 30 Nm.

11. Use the bolt (removed in Step 4) to secure the bracket on the exhaust pipe (18) to the iL system.
12. Continue at Section 6.5.2 to clean and refit the check-valve (17).

### **6.5.2 Clean and refit the check-valve (if fitted)**

1. Refer to Figure 6-3. Unscrew the two halves (2, 4) of the check-valve body (if necessary, use a strap wrench, then remove the fluoroelastomer ball (3) and the 'O' ring (6).
2. Use a cleaning solution suitable for the deposits to clean the valve body and the fluoroelastomer ball. If necessary, replace the fluoroelastomer ball.
3. Inspect the 'O' ring groove and the flange sealing-faces for damage; refinish if necessary.
4. Position the 'O' ring in its groove in the valve body (4).
5. Ensure that the fluoroelastomer ball (3) is correctly positioned in the valve body, then screw the two halves of the valve body (2, 4) together.
6. Refer to Figure 1-1 Use a new trapped 'O' ring (supplied in the check-valve servicing kit: see Section 8.3) and the clamp (removed in Section 6.5.1) to secure the check-valve (17) to the exhaust pipe (18). Ensure that the flow direction arrow on the check-valve (Figure 6-3, item 7) points away from the exhaust pipe towards the exhaust-extraction system.
7. Use a new NW40 trapped 'O' ring and the NW40 clamp (removed in Section 6.5.1) to secure the check-valve outlet to the exhaust-extraction system.

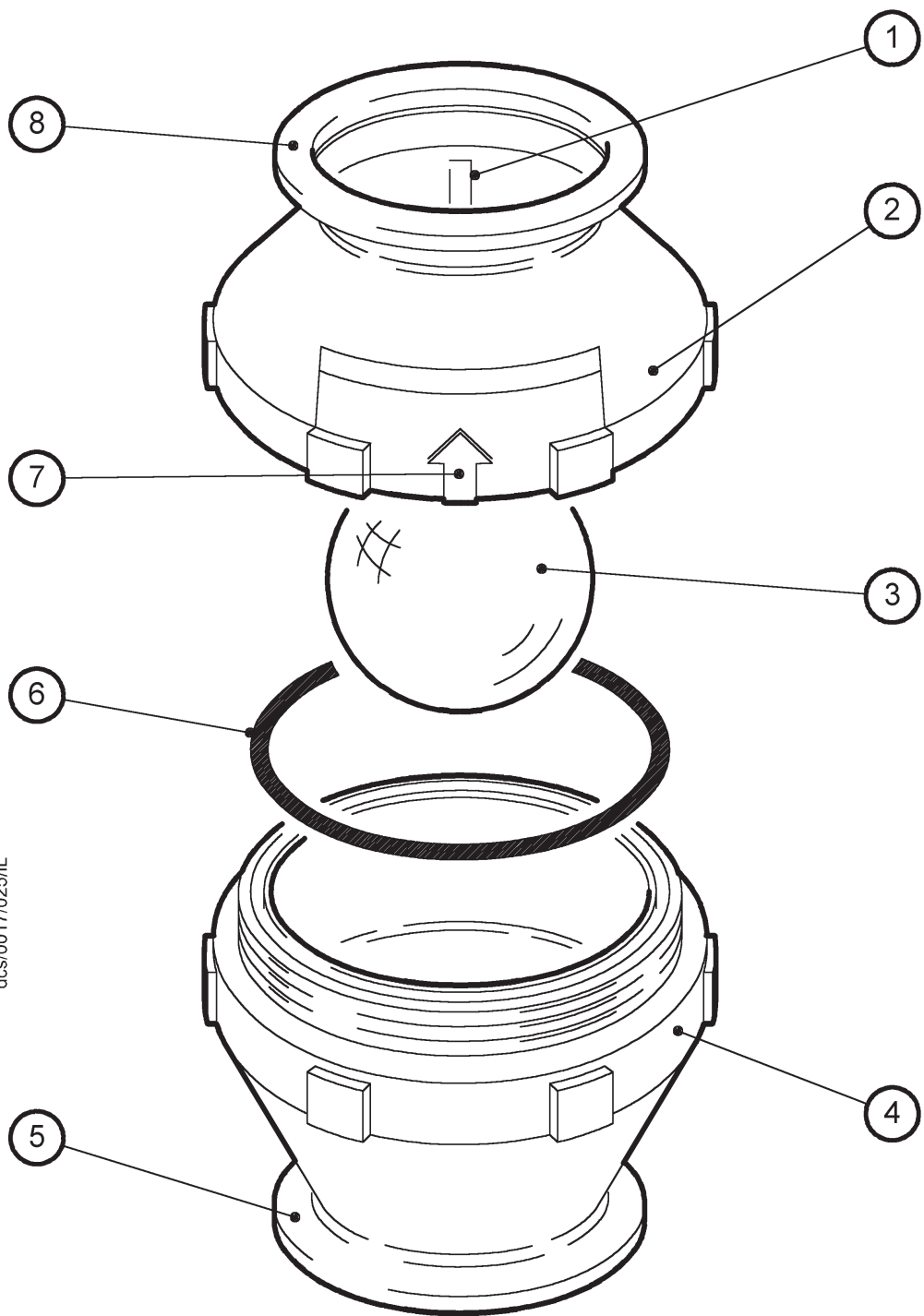

dcs/0017/025/iL

- |                         |                         |
|-------------------------|-------------------------|
| 1. Spider leg           | 5. Inlet-flange         |
| 2. Valve body (female)  | 6. 'O' ring             |
| 3. Fluoroelastomer ball | 7. Flow direction arrow |
| 4. Valve body (male)    | 8. Outlet-flange        |

Figure 6-3 - Clean the exhaust check-valve

## 6.6 Check the LCMB pump oil-level (iL600 only)

### WARNING

If you have pumped dangerous substances, ensure that you purge the iL system (refer to Section 6.1.2) before you remove the oil filler-plug.

### WARNING

Do not remove the oil filler-plug while the pump is operating. If you do, hot oil may be ejected from the pump.

### CAUTION

Do not check the oil-level when the iL system is operating. The correct oil-level may not be shown when the pump is operating.

### CAUTION

Ensure that the oil-level in the LCMB pump is correct. If the pump oil-level is incorrect, pump performance may be affected and the pump may be damaged.

*Note: If there is a significant loss of oil from the pump, the shaft-seals or the spinning filters may have failed. You cannot replace these items. Contact your supplier or BOC Edwards for advice.*

You must check the oil-level every three months; use the following procedure:

1. Purge the system (refer to Section 6.1.2), then shut down the iL system (refer to Section 5.8) and allow it to cool.
2. Remove the right-hand side LCMB enclosure panel from the iL system: refer to Section 3.4.
3. Refer to Figure 1-1. Check the oil-level against the MAX and MIN mark (see detail B) on the bezel of the LCMB oil-level sight-glass (4):

If the oil-level is above the MAX mark, drain excess oil from the pump as described in Section 6.9 until the oil-level is correct.

If the oil-level is below the MIN mark, fill the pump with oil until the oil-level is correct, as described in Section 6.9.

4. Refit the right-hand side LCMB enclosure panel: refer to Section 3.17.

## 6.7 Check the LCDP pump oil-level

### WARNING

If you have pumped dangerous substances, ensure that you purge the iL system (refer to Section 6.1.2) before you remove the oil filler-plug.

### WARNING

Do not remove the oil filler-plug while the pump is operating. If you do, hot oil may be ejected from the pump.

### CAUTION

Do not check the oil-level when the iL system is operating. The correct oil-level may not be shown when the pump is operating.

### CAUTION

Ensure that the oil-level in the LCDP pump is correct. If the pump oil-level is incorrect, pump performance may be affected and the pump may be damaged.

You must check the oil-level every three months; use the following procedure:

1. Purge the system (refer to Section 6.1.2), then shut down the iL system (refer to Section 5.8) and allow it to cool.
2. Remove the right-hand side LCDP enclosure panel from the iL system: refer to Section 3.4.
3. Refer to Figure 1-1. Check the oil-level against the MAX and MIN mark (see detail B) on the bezel of the LCDP oil-level sight-glass (10):

If the oil-level is above the MAX mark, drain excess oil from the pump as described in Section 6.8 until the oil-level is correct.

If the oil-level is below the MIN mark, fill the pump with oil until the oil-level is correct, as described in Section 6.8.

4. Refit the right-hand side LCDP enclosure panel: refer to Section 3.17.



## 6.8 Change the LCDP pump oil

### WARNING

If you have pumped dangerous substances, ensure that you purge the iL system (refer to Section 6.1.2) before you remove the oil filler-plug.

### WARNING

Do not remove the oil filler-plug while the pump is operating. If you do, hot oil may be ejected from the pump.

### CAUTION

Ensure that the oil-level in the LCDP pump is correct. If the pump oil-level is incorrect, pump performance may be affected and the pump may be damaged.

1. Purge the system (refer to Section 6.1.2), then shut down the iL system (refer to Section 5.8) and allow it to cool.
2. Remove the right-hand side LCDP enclosure panel from the iL system: refer to Section 3.4.
3. Refer to Figure 1-1. Remove the LCDP oil filler-plug (7), then use a suitable pump or syringe to suck the oil out of the pump.
4. Dispose of the old 'O' ring on the oil filler-plug (7) and replace it with a new 'O' ring (available as a spare: refer to Section 8.3).
5. Fill the pump through the filler hole with the correct grade and quantity of oil. Allow the oil to drain into the pump, then check the oil-level on the sight-glass: refer to Section 6.7.
6. Ensure that the new 'O' ring is correctly positioned on the oil filler-plug (7), then refit the filler-plug to the LCDP pump.
7. Refit the right-hand side LCDP enclosure panel: refer to Section 3.17.

## 6.9 Change the LCMB pump oil (iL600 only)

### WARNING

If you have pumped dangerous substances, ensure that you purge the iL system (refer to Section 6.1.2) before you remove the oil filler-plug.

### WARNING

Do not remove the oil filler-plug while the pump is operating. If you do, hot oil may be ejected from the pump.

### CAUTION

Ensure that the oil-level in the LCMB pump is correct. If the pump oil-level is incorrect, pump performance may be affected and the pump may be damaged.

1. Purge the system (refer to Section 6.1.2), then shut down the iL system (refer to Section 5.8) and allow it to cool.
2. Remove the right-hand side LCMB enclosure panel from the iL system: refer to Section 3.4.
3. Refer to Figure 1-1. Remove the LCMB oil filler-plug (2), then use a suitable pump or syringe to suck the oil out of the pump.
4. Dispose of the old 'O' ring on the oil filler-plug (2) and replace it with a new 'O' ring (available as a spare: refer to Section 8.3).
5. Fill the pump through the filler hole with the correct grade and quantity of oil. Allow the oil to drain into the pump, then check the oil-level on the sight-glass: refer to Section 6.6.
6. Ensure that the new 'O' ring is correctly positioned on the oil filler-plug (2), then refit the filler-plug to the LCDP pump.
7. Refit the right-hand side LCMB enclosure panel: refer to Section 3.17.

## 6.10 Adjust the Pump Display Module display viewing angle (if fitted)

If the display (Figure 1-6, item 2) is difficult to see, use the following procedure to adjust the display viewing angle. Refer to Figure 3-6.

1. Remove the Pump Display Module (7) from the recess (5) in the front panel.
2. Place or hold the Pump Display Module in its normal operating orientation.
3. Turn the display adjuster (8) clockwise or anticlockwise until the display is easy to read.
4. Refit the Pump Display Module (7) in the recess (5) in the front panel.
5. If necessary, repeat Steps 1 to 4 until the display is easy to see.

## 6.11 Replace a fuse

### WARNING

Ensure that you replace a fuse with a new fuse of the correct rating. If you do not, the iL system will not be adequately protected and you can damage the iL system or cause injury to people.

*Note:* You can only change the fuses in fuse holders F7, F8 and F9. A BOC Edwards service engineer must change other fuses in the Electrics and Pump Control Module (see Figure 1-4).

You can only change the low voltage fuses F7 to F9 for the d.c. electrical supply, the iL Interface Module and the emergency stop circuit. If any of the internal fuses have failed, you must contact your supplier or BOC Edwards for advice. Only change a fuse if you have identified and rectified the cause of the failure.

To change a fuse, refer to Figure 1-4 and use the following procedure. If the fuse immediately fails when you replace it, there may be an electrical fault: contact your supplier or BOC Edwards for advice.

1. Use a flat-bladed screwdriver to undo the fuse holder (13, 14 or 15) by a  $1/4$  of a turn, then remove the fuse holder from the Electrics and Pump Control Module.
2. Remove the failed fuse from the fuse holder.
3. Fit a new fuse of the correct rating in the fuse holder. Refer to Section 2 for the fuse ratings.
4. Refit the fuse holder in the Electrics and Pump Control Module, then use a flat-bladed screwdriver to turn the fuse holder clockwise by a  $1/4$  of a turn to secure it in place.

## 6.12 Replace the Pump Display Module

Use the following procedure to replace the Pump Display Module. Note that you do not need to switch off the iL system to replace the Pump Display Module.

1. Refer to Figure 3-6. Remove the Pump Display Module (7) from the recess (5) in the front panel.
2. Remove the connector (4) on the cable (6) from the connector (3) in the recess of the front panel.
3. Fit the new Pump Display Module as described in Section 3.8.1.

## 6.13 Relocate the iL system for maintenance

### WARNING

Use suitable lifting equipment to move the iL system.

If you want to remove the iL system from its operating location and move it to another location where you will do maintenance, use the following procedure.

1. Purge the iL system (refer to Section 6.1.2), then shut down the iL system as described in Section 5.8 and allow the iL system to cool down.
2. Refer to Figure 3-10. Disconnect the mating-half from the electrical supply connector (9) on the Electrics and Pump Control Module.
3. Refer to Figure 1-4. Switch off your cooling-water supply, then disconnect the cooling-water supply and return pipelines from the cooling-water inlet and outlet (3, 2).
4. Refer to Figure 1-1. Disconnect the inlet (1) from your vacuum system and disconnect the outlet (16) from your exhaust-extraction system. Fit blanking caps to your vacuum and exhaust-extraction pipelines and to the iL inlet and outlet (1, 16).
5. If necessary, disconnect the iL air-extraction port (see Figures 2-1 and 2-2) from your factory extraction system.
6. Refer to Figure 1-1. Adjust the levelling feet (8) so that the iL system rests on the castors (9).
7. Refer to Figure 3-5. If necessary (that is, if you want to use lifting equipment to move the iL system), refit the four transit brackets to the vibration isolators: refit each transit bracket (2) to the vibration isolator (3), then refit the nuts and washers (4) to secure the transit brackets in place.
8. Move the iL system to the location where you want to do maintenance.
9. If necessary (depending on the maintenance you will do), disconnect any accessories from the iL system.

After maintenance is complete, re-install the iL system as described in Section 3.

## 6.14 Fault finding

### 6.14.1 Warning and alarm message fault finding

When a warning or alarm message is generated, you can display the message and (for some of the messages) two lines of text (the advisory message) which identify possible checks you can make to identify the cause of the fault and to rectify the fault.

The first line of a message specifies the fault condition (warning or alarm) and shows the error number. Error numbers are of the form PFF, PPF or PPPFF, where:

P, PP, or PPP specifies the fault parameter associated with the alarm or warning: refer to Table 6-4.

FF specifies the fault type type: refer to Table 6-5.

Table 6-1 shows all of the warning messages, the corresponding lines of advisory text (if any) and the meaning of the error/recommended actions. The warning messages are given in error number order in this table.

Table 6-2 shows all of the alarm messages, the corresponding lines of advisory text (if any) and the meaning of the error/recommended actions. The alarm messages are given in error number order in this table.

Note that Tables 6-1 and 6-2 show all of the possible warning and alarm messages, however some of these messages may not be displayed: this depends on how you have adjusted the setpoints. For example, warning 409 (DP POWER LOW) may not appear if you have configured the system not to display the warning.

### 6.14.2 Other fault finding

Fault messages will be shown on the Pump Display Module to identify that the action you have selected cannot be carried out. The messages which can be displayed and their meanings are shown in Table 6-3.

Warning message	Advisory message	Meaning/recommended action
WARNING 101		(a) there is a fault in the Sensor Monitoring Module PCA, or (b) a module or sensor which should be fitted is not fitted or is disconnected, or (c) the emergency stop button has been pressed (or a safety sensor has operated or your external emergency stop switch has been operated) to shut down the iL system, or (d) there has been a transient electrical supply failure (longer than the hold-up time of the iL power supply), or (e) the wrong gas module is fitted for the current iL configuration.
WARNING 113		There is a fault in the ADC (Analogue-to-digital convertor) in the Sensor Monitoring Module; the ADC must be replaced.
WARNING 209	SEE MANUAL	The electrical supply voltage is too low. Check the electrical supply and the connections to the iL system and rectify as necessary.
WARNING 211	SEE MANUAL	The electrical supply voltage is too high. Check the electrical supply and the connections to the iL system and rectify as necessary.
WARNING 309 DP CURRENT LOW	OPEN CIRCUIT CHECK CONNECTION	The electrical current drawn by the LCDP pump is less than normal. Check that the electrical connections are correct and rectify as necessary. If the electrical connections are correct, a fuse in the Electrics and Pump Control Module may have failed.
WARNING 311 DP CURRENT HIGH	LEAK/DEBRIS SERVICE PUMP	The electrical current drawn by the LCDP pump is higher than normal. There may be a leak in the system or process debris in the pump, or the pump motor may have failed. Inspect the pipelines and service the pump.
WARNING 409 DP POWER LOW	OPEN CIRCUIT CHECK CONNECTION	The electrical power consumption of the LCDP pump is less than normal. Check that the electrical connections are correct and rectify as necessary. If the electrical connections are correct, a fuse in the Electrics and Pump Control Module may have failed.
WARNING 411 DP POWER HIGH	LEAK/DEBRIS SERVICE PUMP	The electrical power consumption of the LCDP pump is higher than normal. There may be a leak in the system or process debris in the pump, or the pump motor may have failed. Inspect the pipelines and service the pump.

Table 6-1 - Warning messages

Warning message	Advisory message	Meaning/recommended action
WARNING 412	LEAK/DEBRIS SERVICE PUMP	Refer to the recommendations for error 4.11 (in this table).
WARNING 509	SEE MANUAL	The LCDP motor thermistor is short circuited. Check the thermistor connections inside the LCDP pump motor terminal-box and check the connections between the LCDP pump and the Electrics and Pump Control Module.
WARNING 611	SEE MANUAL	There is a phase imbalance in the electrical supply to the LCDP pump. Check the electrical supply and the connections to the iL system. If the electrical supply and connections are correct, the pump motor may be faulty.
WARNING 709 MB CURRENT LOW	OPEN CIRCUIT CHECK CONNECTION	The electrical current consumption of the LCMB pump is lower than normal. Check that the electrical connections are correct and rectify as necessary. If the electrical connections are correct, a fuse in the Electrics and Pump Control Module may have failed.
WARNING 711 MB CURRENT HIGH	LEAK/DEBRIS SERVICE PUMP	The electrical current consumption of the LCMB pump is higher than normal. There may be a leak in the system or process debris in the pump, or the pump motor may have failed. Inspect the pipelines and service the pump.
WARNING 809 MB POWER LOW	OPEN CIRCUIT CHECK CONNECTION	The electrical power consumption of the LCMB pump is lower than normal. Check that the electrical connections are correct and rectify as necessary. If the electrical connections are correct, a fuse in the Electrics and Pump Control Module may have failed.
WARNING 811 MB POWER HIGH	LEAK/DEBRIS SERVICE PUMP	The electrical power consumption of the LCMB pump is higher than normal. There may be a leak in the system or process debris in the pump or the pump motor may have failed. Inspect the pipelines and service the pump.
WARNING 812 MB POWER HIGH	LEAK/DEBRIS SERVICE PUMP	Refer to the recommended actions for error number 811 in this table.
WARNING 909	SEE MANUAL	The LCMB motor thermistor is short circuited. Check the thermistor connections inside the LCMB pump motor terminal-box and check the connections between the LCMB pump and the Electrics and Pump Control Module.

Table 6-1 - Warning messages (continued)

Warning message		Advisory message	Meaning/recommended action
WARNING	1011	SEE MANUAL	There is a phase imbalance in the electrical supply to the LCMB pump. Check the electrical supply and the connections to the iL system. If the electrical supply and connections are correct, the pump motor may be faulty.
WARNING	1201		When started, no electrical current was drawn by the LCDP pump. Check whether the pump motor is open circuit. If not, the current sensor may have failed.
WARNING	1401 SERVICE DUE (R)	xxxxx HRS RUN SINCE SERVICE	The iL system has operated for xxxxx hours since it was last serviced. Service the iL system.
WARNING	1601 SERVICE DUE (P)	xxxxx HRS RUN SINCE SERVICE	The iL system has operated for xxxxx hours since it was last serviced. Service the iL system.
WARNING	1801 SERVICE DUE (P)	xxxxx CYCLES SINCE SERVICE	The iL system has been operated for xxxxx process cycles since it was last serviced. Service the iL system.
WARNING	2001 SERVICE DUE (C)	xxxxx CYCLES SINCE SERVICE	The iL system has been operated for xxxxx switch-on/off cycles since it was last serviced. Service the system.
WARNING	3113		There is a fault in the ADC (analogue-to-digital convertor) in the gas module; the ADC must be replaced.
WARNING	4009 SS PURGE LOW	ADJUST REGULATOR INCREASE PRESS.	The shaft-seals purge pressure is too low. Check that the nitrogen supply is as specified in Section 2 and that you have correctly adjusted the pressure: refer to Section 5.5.
WARNING	4010 SS PURGE LOW	PRESSURE LOW ADJUST REGULATOR	Refer to the recommended actions for error number 4009 in this table.
WARNING	4011 SS PURGE HIGH	PRESSURE HIGH CHECK GAS MODULE	The shaft-seals purge pressure is too high. Check that you have correctly adjusted the pressure: refer to Section 5.5. If you cannot correctly adjust the pressure, the regulator may be faulty.
WARNING	4012 SS PURGE HIGH	PRESSURE HIGH CHECK GAS MODULE	Refer to the recommended actions for error number 4011 in this table.
WARNING	4013		The shaft-seals pressure transducer is not fitted, or is disconnected or has failed. Check and rectify as necessary.

Table 6-1 - Warning messages (continued)



Warning message	Advisory message	Meaning/recommended action
WARNING 5101		The Sensor Monitoring Module may be disconnected. If the wiring connections are correct, the PCA may be faulty.
WARNING 5113		There is a fault in the ADC (analogue-to-digital convertor) in the Sensor Monitoring Module; the ADC must be replaced.
WARNING 5411 MB TEMP		The temperature of the LCMB pump is too high. Check the pumping system inlet pressure; has the pumping system been operating with inlet pressure > 5 mbar ( $5 \times 10^2$ Pa) for 1 hour or more. If the maximum inlet pressure has not been exceeded, or if the pumping system has not been operated at the maximum inlet pressure for longer than the specified time, the cooling-circuit of the pump maybe blocked.
WARNING 5413		Check that the LCMB pump temperature sensor is fitted and is correctly connected. If the sensor is correctly fitted and connected, it may have failed. Check the operation of the sensor and replace it if it has failed.
WARNING 5511 DP MOTOR TEMP	MOTOR WATER LOW CHECK WATER	The temperature of the LCDP pump- motor is too high. Check the cooling-water connections in the iL system and check that the cooling-water supply is on and is as specified in Section 2. If the connections and supply are correct, the cooling-circuit of the pump maybe blocked.
WARNING 5513		The LCMB pump-motor surface temperature sensor is not fitted, or is disconnected or has failed.
WARNING 5709 DP TEMP LOW	DP TEMP LOW SEE MANUAL	The operating temperature of the LCDP pump is too low.
WARNING 5711 DP TEMP HIGH	DP TEMP HIGH SEE MANUAL	The operating temperature of the LCDP pump is too high: there may be process debris in the pump or the pump may be damaged.
WARNING 5713		The LCDP pump-body temperature sensor is not fitted, or is disconnected or has failed. Check and rectify as necessary.
WARNING 6001 WATER FLOW LOW	CHECK COOLING WATER SUPPLY	The flow of cooling-water through the iL system is too low. Refer to the recommended actions for error number 5411.

Table 6-1 - Warning messages (continued)

Warning message	Advisory message	Meaning/recommended action
WARNING 11101		There is a fault in the NIM (Network Interface Module): refer to the instruction manual supplied with the NIM.
WARNING 12101		There is a fault in the Tool Interface Card in the iL Interface Module. Refer to the instruction manual supplied with the iL Interface Module.
WARNING 15101		There is a fault in the Auxiliary Interface Card in the iL Interface Module. Refer to the instruction manual supplied with the iL Interface Module.

Table 6-1 - Warning messages (continued)

<b>Alarm message</b>	<b>Advisory message</b>	<b>Meaning/recommended action</b>
ALARM 101 STOP ACTIVATED		The emergency stop switch has been pressed or a safety sensor connected to the emergency stop circuit has operated (or your remote emergency off circuit has operated) to shut down the iL system. Note that the message will remain on the display until you restart the pumping system.
ALARM 101		Refer to the recommended actions for error number 101: see Table 6-1.
ALARM 210		Refer to the recommended actions for error number 209: see Table 6-1.
ALARM 212		Refer to the recommended actions for error number 211: see Table 6-1.
ALARM 310 DP CURRENT LOW	OPEN CIRCUIT CHECK CONNECTION	Refer to the recommended actions for error number 309: see Table 6-1.
ALARM 312 DP CURRENT HIGH	LEAK/DEBRIS SERVICE PUMP	Refer to the recommended actions for error number 311: see Table 6-1.
ALARM 410 DP POWER LOW	OPEN CIRCUIT CHECK CONNECTION	Refer to the recommended actions for error number 409: see Table 6-1.
ALARM 412 DP POWER HIGH	LEAK/DEBRIS SERVICE PUMP	Refer to the recommended actions for error number 411: see Table 6-1.
ALARM 512		The pump-motor has tripped out because the motor windings are too hot: either the cooling-system has failed or the motor overloaded. Either of these faults should have been identified before shut-down, so either there are two separate faults (for example, cooling-water supply failure and thermocouple circuit failure) or the thermistor circuit has failed: contact your supplier or BOC Edwards.
ALARM 612		Refer to the recommended actions for error number 611: see Table 6-1.
ALARM 710 MB CURRENT LOW	OPEN CIRCUIT CHECK CONNECTION	Refer to the recommended actions for error number 709: see Table 6-1.
ALARM 712 MB CURRENT HIGH	LEAK/DEBRIS SERVICE PUMP	Refer to the recommended actions for error number 711: see Table 6-1.
ALARM 810 MB POWER LOW	OPEN CIRCUIT CHECK CONNECTION	Refer to the recommended actions for error number 809: see Table 6-1.
ALARM 812 MB POWER HIGH	LEAK/DEBRIS SERVICE PUMP	Refer to the recommended actions for error number 811: see Table 6-1.

Table 6-2 - Alarm messages

<b>Alarm message</b>	<b>Advisory message</b>	<b>Meaning/recommended action</b>
ALARM 912		Refer to the recommended actions for error number 512 in this table.
ALARM 1012		Refer to the recommended actions for error number 1011: see Table 6-1.
ALARM 1101		(a) the electrical supply is not connected to the LCDP pump-motor, or (b) the LCDP pump has started, but has then immediately stopped again, because the phase sequence of the electrical supply to the pump is incorrect: reverse two of the phases in the electrical supply connector: refer to Section 3.15.3).
ALARM 1201		When started, no electrical current was drawn by the LCMB pump. Check whether the pump motor is open circuit. If not, the current sensor may have failed.
ALARM 5412 MB TEMP	MB TEMP HIGH SEE MANUAL	Refer to the recommended actions for error number 5411: see Table 6-1.
ALARM 5512 DP MOTOR TEMP	MOTOR WATER LOW CHECK WATER	Refer to the recommended actions for error number 5511: see Table 6-1.
ALARM 5710 DP TEMP LOW	DP TEMP LOW SEE MANUAL	Refer to the recommended actions for error number 5709: see Table 6-1.
ALARM 5712 DP TEMP HIGH	DP TEMP HIGH SEE MANUAL	Refer to the recommended actions for error number 5711: see Table 6-1.

Table 6-2 - Alarm messages (continued)

<b>Message</b>	<b>Meaning</b>
CONTROL failed Press CANCEL	You have requested that the Pump Display Module takes control of the iL system, but the attempt to take control has failed. Press the CANCEL button to return to normal display.
CONTROL REMOTE Press CANCEL	(a) You have requested that the Pump Display Module takes control of the iL system, but another module still has control. Press the CANCEL button to return to normal display, release control from the module which currently has control and then try again.  (b) You have requested some action, but the Pump Display Module does not have control of the iL system. Press the CANCEL button, take control and then try again.
PUMP failed to respond (CANCEL)	(a) You have requested that the iL system is switched on or off, but the pump(s) has failed to start or stop: press the CANCEL button to cancel the request, identify and rectify the cause for the failure of the pump(s) to start or stop, then try again.  (b) You have tried to open or close one of the gate valves (if fitted), but the valve has failed to respond. Identify and rectify the cause for the failure of the valve to open or close, then try again.  (c) A value (for example, a setpoint) has been requested from the iL system, but the iL system has not responded.  (d) The emergency stop switch has been pressed and released: restart the pumping system.
PUMP RUNNING Press CANCEL	You have requested that the iL system is switched on, but it is already on. Press the CANCEL button to return to normal display.
PUMP STOPPED Press CANCEL	You have requested that the iL system is switched off, but it is already off. Press the CANCEL button to return to normal display.
EDWARDS DISPLAY MODULE	If this message is displayed when the iL system is switched on and the display does not change to normal display, this means that the Pump Display Module cannot correctly communicate with the iL system.
None (the display is blank)	One or both of fuses F6 and F8 may have tripped. Switch off the electrical supply to the iL system, then switch it on again to reset the fuse(s).

Table 6-3 - Fault messages

Parameter †	Source/cause of error
1	iL system status
2	Electrical supply voltage
3	LCDP pump current consumption
4	LCDP pump power consumption
5	LCDP pump-motor thermistor
6	Phase imbalance in LCDP pump current consumption
7	LCMB pump current consumption ▲
8	LCMB pump power consumption ▲
9	LCMB pump-motor thermistor ▲
10	Phase imbalance in LCMB pump current consumption ▲
11	LCDP pump status
12	LCMB pump status ▲
14	Total run hours (since last service)
16	Total run hours (on process, since last service)
18	Process cycles (since last service)
20	Switch-on/off cycles (since last service)
31	ADC (analogue to digital convertor)
40	Shaft-seals purge pressure transducer #
51	Sensor Monitoring Module status #
53	Active Gauge # *
54	LCMB pump temperature sensor # ▲
55	LCDP pump-motor water manifold surface temperature sensor #
57	LCDP pump-body thermocouple #
111	Network Interface Module status *
121	Tool Interface Card status *
151	Auxiliary Interface Card status *

† First digit of a three-digit error number, first two digits of a four-digit error number, or first three digits of a five-digit error number.

# Sensor-configured iL systems only.

\* Optional accessory.

▲ iL600 only

Table 6-4 - Fault parameters

Fault type ▲	Meaning
01	Digital alarm condition *
09	Low warning condition
10	Low alarm condition
11	High warning condition
12	High alarm condition
13	Device error †

▲ Last two digits of the error number.

\* For example, a pressure transducer has drifted outside the valid range.

† For example, sensor is not fitted, or is disconnected.

Table 6-5 - Fault types

## 6.15 Check for free rotation of the LCDP pump

If the iL has automatically shut down because of excessive LCDP pump-motor power (that is alarms 412 or 512 are displayed), use the following procedure to check that the pump is free to rotate before you restart the iL system:

1. Refer to Figure 3-10. Disconnect the mating-half from the electrical supply connector (9) on the Electrics and Pump Control Module.
2. Refer to 1-4. Undo and remove the four screws which secure the rear cover (1), then remove the cover.
3. Refer to Figure 6-4. Use a 100mm A/F hexagonal key to remove the 3/8 BSP plug and 'O' ring (2) from the motor shaft.
4. Fit the hexagonal key to the end of the motor shaft and try to turn the shaft clockwise (in the direction shown by the arrow, 3):

If the shaft is free to turn, remove the hexagonal key and continue at Step 5.

If the shaft is not free to turn, contact your supplier or Edwards: do not try to restart the iL system.

5. Refit the plug and 'O' ring (2) to the motor shaft.
6. Refer to Figure 1-4. Refit the rear cover (1) and secure with the four screws.
7. Refer to Figure 3-10. Refit the mating-half to the electrical supply connector (9) on the Electrics and Pump Control Module.

You can now restart the iL system: refer to Section 5.12



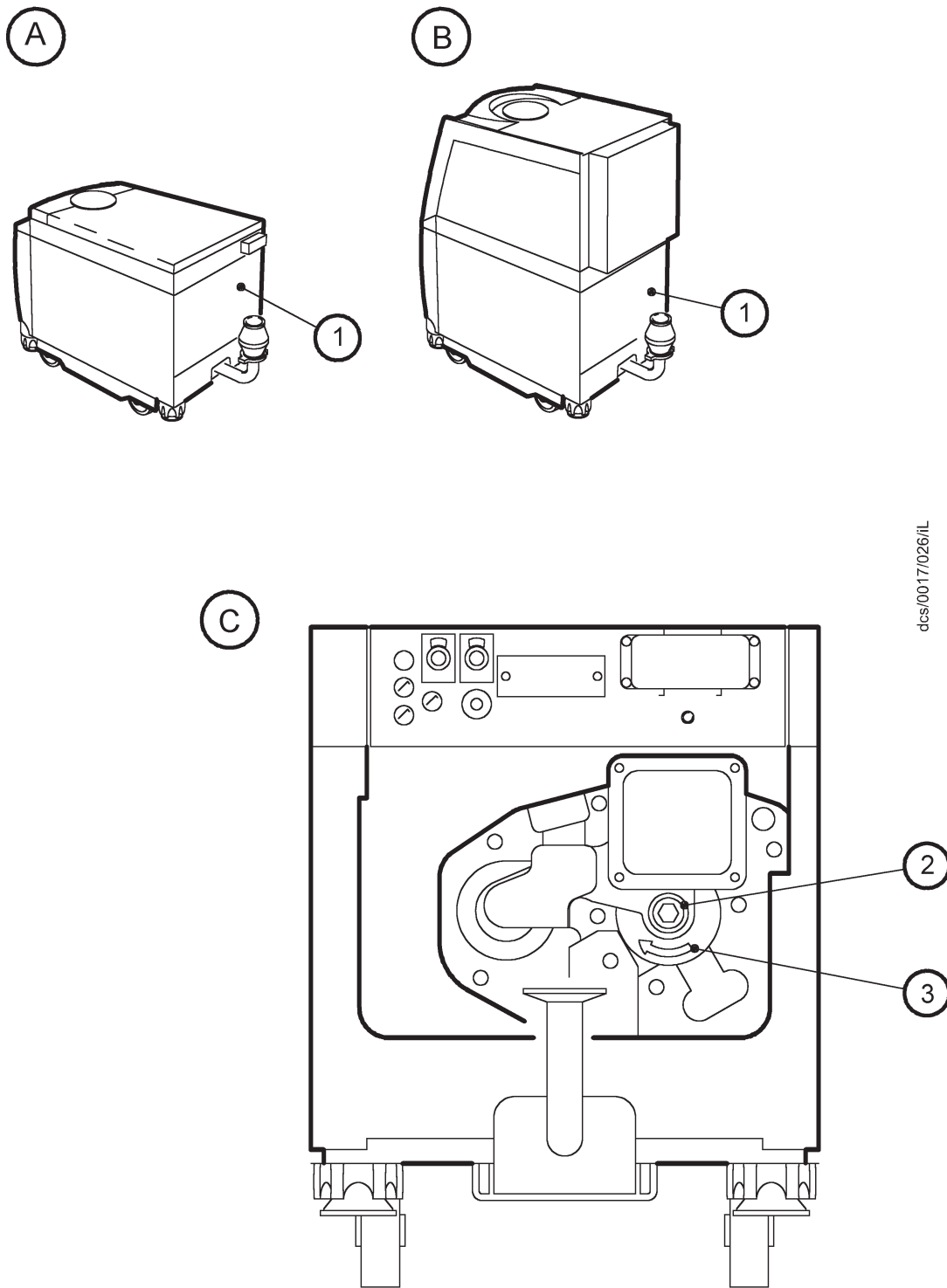

dcsl/0017/026/iL

- A iL70
- B iL600

- 1. Rear cover
- 2. Plug and 'O' ring: 3/8 BSP
- 3. Correct direction of rotation arrow

Figure 6-4 - Try to turn the LCDP pump

## 7 STORAGE, DISPOSAL AND TRANSPORTATION

### 7.1 Storage

#### WARNING

Do not drain the oil from the pump(s) if you know that dangerous substances have been pumped, or if you are unsure whether dangerous substances have been pumped or not.

#### CAUTION

Drain the cooling-water from the iL system, if you want to store it in conditions where the cooling-water could freeze. If you do not, cooling-water may freeze in the iL system and damage the pump and/or the cooling-water pipelines.

Store the iL system as follows :

1. If applicable, ensure that the iL system has been purged (see Section 6.1.2) and shut down (see Section 5.8) and disconnect all services, process and exhaust connections.
2. If the LCDP pump and LCMB pump (on an iL600 system) have been filled with oil:  

If you know that dangerous substances have been pumped, or if you are unsure whether dangerous substances have been pumped or not, leave the oil in the pump(s). Do **not** drain the oil.

Drain the oil from the pump(s) (as described in Section 6.8 or 6.9) **only** if you are certain that dangerous substances have not been pumped.
3. Fit blanking-plates to all vacuum inlets and exhaust outlets. Place protective covers over the iL services connection points.
4. Store the iL system in clean dry conditions until required.
5. When required for use, prepare and install the iL system as described in Section 3 of this manual.

### 7.2 Disposal

Dispose of the iL system and any components safely in accordance with all local and national safety and environmental requirements.

Take particular care with the following:

Fluorinated materials which may have decomposed as the result of being subjected to high temperatures

Components and oil which have been contaminated with dangerous process substances.

## 7.3 Transportation

### WARNING

Do not drain the oil from the pump(s) if you know that dangerous substances have been pumped, or if you are unsure whether dangerous substances have been pumped or not.

### WARNING

If you have to transport the iL system with the pump(s) filled with oil, you must fit blanking plates to seal all vacuum inlet and outlet ports (to prevent possible oil leakage).

### CAUTION

Drain the cooling-water from the iL system, if you want to transport it in conditions where the cooling-water could freeze. If you do not, cooling-water may freeze in the iL system and damage the pump and/or the cooling-water pipelines.

*Notes: The LCDP pump (and on iL600 systems, the LCMB pump) is supplied fitted with a transit seal. This seal has a finite serviceable life. If the iL system is transported with the pump(s) full of oil when the transit seal is no longer serviceable, oil may leak into the swept volume of the pump(s).*

*You must provide a correctly completed Return of Equipment Declaration (form HS2) if you return the iL system to BOC Edwards: refer to Section 8.2.*

If you want to transport the iL system (either for onward shipment to your own customer, or for return to BOC Edwards for repair), before you transport it:

1. If applicable, ensure that the iL system has been purged (see Section 6.1.2) and shut down (see Section 5.8) and disconnect all services, process and exhaust connections.
2. If the LCDP pump and LCMB pump (on an iL600 system) have been filled with oil:
  - If you know that dangerous substances have been pumped, or if you are unsure whether dangerous substances have been pumped or not, leave the oil in the pump(s). Do **not** drain the oil.
  - Drain the oil from the pump(s) (as described in Section 6.8 or 6.9) **only** if you are certain that dangerous substances have not been pumped.
3. Fit blanking-plates to seal all vacuum inlet and outlet ports. Place protective covers over the iL services connection points.

## 8 SERVICE, SPARES AND ACCESSORIES

### 8.1 Introduction

BOC Edwards products, spares and accessories are available from BOC Edwards companies in Belgium, Brazil, Canada, China, France, Germany, Israel, Italy, Japan, Korea, Singapore, Switzerland, United Kingdom, U.S.A and a world-wide network of distributors. The majority of these centres employ Service Engineers who have undergone comprehensive BOC Edwards training courses.

Order spare parts and accessories from your nearest BOC Edwards company or distributor. When you order, please state for each part required:

Model and Item Number of your equipment

Serial number (if any)

Item Number and description of the part.

### 8.2 Service

#### WARNING

Do not drain the oil from the pump(s) if you know that dangerous substances have been pumped, or if you are unsure whether dangerous substances have been pumped or not.

*Note: Whenever you return the iL system to a BOC Edwards Service Centre or other BOC Edwards company, you must comply with the requirements of Section 7.3 and with the requirements of the Return of BOC Edwards Equipment Procedure (see forms HS1 and HS2 at the end of this manual).*

*Note that you must not drain the oil from the pump(s) if the iL system has been contaminated with dangerous substances (see Section 7.3). If you return the iL system with the pump(s) full of oil, you must clearly state this when you complete form HS2.*

BOC Edwards products are supported by a world-wide network of BOC Edwards Service Centres. Each Service Centre offers a wide range of options including: equipment decontamination; service exchange; repair; rebuild and testing to factory specifications. Equipment which has been serviced, repaired or rebuilt is returned with a full warranty.

Your local Service Centre can also provide BOC Edwards engineers to support on-site maintenance, service or repair of your equipment.

For more information about service options, contact your nearest Service Centre or other BOC Edwards company.

## 8.3 Spares

Spare	Item Number
Fomblin 25/6 oil (1 kg)	H113-12-019
Krytox 1525 oil (1 kg)	H113-09-018
Drynert 25/6 oil (1 kg)	H113-12-021
Exhaust check-valve servicing kit	A440-03-820
iL Tool Interface Module connector plug	A532-20-050
Exhaust pipe (as supplied)	A408-02-038
Metal 'O' ring (for LCDP outlet/exhaust pipe connection)	H021-15-000
Oil filler-plug 'O' ring (pack of 10)	H021-06-110

## 8.4 Ordering Accessories

*Note: All of the accessories in Section 8.4.1, 8.4.4 and 8.4.8 must be ordered when you order your iL system. The accessories you have ordered will be supplied fitted to your iL system.*

### 8.4.1 iL Enclosure Extraction Fan Kit

When fitted, an iL Enclosure Extraction Fan Kit provides air-extraction of the iL enclosure at a rate of  $2.8 \text{ m}^3 \cdot \text{min}^{-1}$  (100 cfm).

Accessory	Item Number
iL Enclosure Extraction Fan Kit	A505-39-000

### 8.4.2 Pump Display Module

The Pump Display Module allows you to manually control the iL system and to display the status of the iL system: refer to Section 1.11.

Accessory	Item Number
Pump Display Module	D372-37-000

### 8.4.3 iL Pump Display Module extension cables

If required, you can use an extension cable to allow you to use the Pump Display Module further away from the iL system.

Accessory	Item Number
Extension cable (display/interface), 3 m	D372-07-591
Extension cable (display/interface), 5 m	D372-07-592
Extension cable (display/interface), 10 m	D372-07-595
Extension cable (display/interface), 15 m	D372-07-596
Extension cable (display/interface), 25 m	D372-07-597

#### 8.4.4 Active Gauge Connection Kit (sensor-configured iL systems only)

Fit an Active Gauge Connection Kit to a sensor-configured iL system to allow the iL system to monitor the pressure measured by an Active Gauge fitted in the inlet pipeline to the iL system. Note that you need to fit an iL PC Interface Kit (see Section 8.4.6) when you fit an Active Gauge Connection Kit, and that you cannot fit an Active Gauge Connection Kit if you have fitted an iL Pressure Control Kit: see Section 8.4.8.

The Connection Kit is suitable for use with any of the following BOC Edwards Active Gauges: ATC-M Active Thermocouple Gauge; ASG (1000 mbar) Active Strain Gauge; APG-MP Active Pirani Gauge.

Accessory	Item Number
Active Gauge Connection Kit	D372-41-000

#### 8.4.5 iL Interface Modules

The iL Interface Module allows you to control the operation of the iL system through your Process Tool or other control equipment.

The iL Interface Module can be fitted with one or more Tool Interface Card and/or one or more Auxiliary Interface Card.

The Tool Interface Card allows you to control and monitor the status of the iL system through your process tool or other control equipment. The Tool Interface Card has a setpoints store. The setpoints store can be preset to contain sensor setpoints suitable for a particular process or application (that is, the combination of the iL system configuration, process chemistry and user's production pattern). If you have a Tool Interface Card fitted, you can use the application recipe at any time (instead of the default setpoints in the iL system).

The Auxiliary Interface Card allows you to control the operation of other equipment (such as inlet and outlet isolation-valves) connected to the iL system.

Contact your supplier or BOC Edwards if you want to order iL Interface Modules.

#### 8.4.6 iL PC Interface Kits

The iL PC Interface Kit allows you to directly connect the iL system to a laptop or desktop PC and to use the PC to switch the iL system on and off, and to monitor the status of the iL system. The Kit is supplied with all necessary cables and with the iL Single Pumpset Monitor software.

Accessory	Item Number
Desktop PC Interface Kit	D372-18-100
Laptop PC Interface Kit (USA)	D372-18-200
Laptop PC Interface Kit (Europe)	D372-18-300
Laptop PC Interface Kit (UK)	D372-18-400
Laptop PC Interface Kit (Japan)	D372-18-500

### 8.4.7 iL Central Monitoring System

The iL Central Monitoring System allows you to network together all of the iL systems in your installation, and to use a PC to centrally monitor the iL systems. Contact your supplier or BOC Edwards if you want to network your iL systems.

### 8.4.8 iL600 Pressure Control Kit (sensor configured iL systems)

Fit an iL600 Pressure Control Kit to an iL600 system to enable the LCMB pump to be automatically started at a preset inlet pressure. Note that you cannot fit an Active Gauge Connection Kit accessory (see Section 8.4.4) if you fit an iL Pressure Control Kit.

Accessory	Item Number
iL Pressure Control Kit	A505-40-000

### 8.4.9 iL Communications Module

Fit a Communications Module accessory to allow your Process Tool or PC-based software to control and monitor the operation of the iL system through a serial port and/or through a parallel port, with a small number of digital lines:

Serial port communications use the RS232C communications protocol.

Parallel port communications implement a sub-set of the iL Tool Interface Module communications. A single digital control input is used to turn the pump(s) on and off, and four digital outputs provide pump(s) on, warning and alarm status outputs.

Accessory	Item Number
iL Serial Communications Module	D372-32-000
iL Serial and Parallel Communications Module	D372-35-000
iL Parallel Communications Module	D372-36-000

### 8.4.10 iL Alternative Nitrogen Connection Kit

Use this kit to reconfigure the iL system to use the alternative nitrogen inlet position (see Section 3.5)

Accessory	Item Number
Alternative Nitrogen Connection Kit	A505-34-000

## Return of BOC Edwards Equipment - Procedure

### INTRODUCTION

Before returning your equipment, you must warn BOC Edwards if substances you used (and produced) in the equipment can be hazardous. This information is fundamental to the safety of our Service Centre employees and will determine the procedures employed to service your equipment.

**Complete the Declaration (HS2) and send it to BOC Edwards before you dispatch the equipment.** It is important to note that this declaration is for BOC Edwards internal use only, and has no relationship to local, national or international transportation safety or environmental requirements. As the person offering the equipment for shipment, it is your responsibility to ensure compliance with applicable laws.

### GUIDELINES

- Equipment is '**uncontaminated**' if it has not been used, or if it has only been used with substances that are not hazardous. Your equipment is '**contaminated**' if it has been used with any substances classified as hazardous under EU Directive 67/548/EEC (as amended) or OSHA Occupational Safety (29 CFR 1910).
- If your equipment has been used with radioactive substances, biological or infectious agents, mercury, polychlorinated biphenyls (PCB's), dioxins or sodium azide, you must decontaminate it before you return it to BOC Edwards. You must send independent proof of decontamination (for example a certificate of analysis) to BOC Edwards with the Declaration (HS2). Phone BOC Edwards for advice.
- If your equipment is contaminated, you must either:
  - Remove all traces of contamination (to the satisfaction of laws governing the transportation of dangerous/hazardous substances).
  - Or, properly classify the hazard, mark, manifest and ship the equipment in accordance with applicable laws governing the shipment of hazardous materials.

**Note: Some contaminated equipment may not be suitable for airfreight.**

### PROCEDURE

1. Contact BOC Edwards and obtain a Return Authorisation Number for your equipment.
2. Complete the Return of BOC Edwards Equipment - Declaration (HS2).
3. If the equipment is contaminated, you must contact your transporter to ensure that you properly classify the hazard, mark, manifest and ship the equipment, in accordance with applicable laws governing the shipment of contaminated/hazardous materials. As the person offering the equipment for shipment, it is your responsibility to ensure compliance with applicable law. **Note: Equipment contaminated with some hazardous materials, such as semiconductor by-products, may not be suitable for airfreight - contact your transporter for advice.**
4. Remove all traces of hazardous gases: pass an inert gas through the equipment and any accessories that will be returned to BOC Edwards. Where possible, drain all fluids and lubricants from the equipment and its accessories.
5. Seal up all of the equipment's inlets and outlets (including those where accessories were attached) with blanking flanges or, for uncontaminated product, with heavy gauge tape.
6. Seal equipment in a thick polythene/polyethylene bag or sheet.
7. If the equipment is large, strap the equipment and its accessories to a wooden pallet. If the equipment is too small to be strapped to a pallet, pack it in a suitable strong box.
8. Fax or post a copy of the Declaration (HS2) to BOC Edwards. The Declaration must arrive before the equipment.
9. Give a copy of the Declaration (HS2) to the transporter. You must tell your transporter if the equipment is contaminated.
10. Seal the original Declaration in a suitable envelope: attach the envelope securely to the outside of the equipment package, in a clear weatherproof bag.

**WRITE YOUR RETURN AUTHORISATION NUMBER CLEARLY ON THE OUTSIDE OF THE ENVELOPE OR ON THE OUTSIDE OF THE EQUIPMENT PACKAGE.**



# Return of BOC Edwards Equipment - Declaration

Return Authorisation Number: \_\_\_\_\_

You must:

- Know about all of the substances which have been used and produced in the equipment before you complete this Declaration
- Read the Return of BOC Edwards Equipment - Procedure (HS1) before you complete this Declaration
- Contact BOC Edwards to obtain a Return Authorisation Number and to obtain advice if you have any questions
- Send this form to BOC Edwards before you return your equipment

## SECTION 1: EQUIPMENT

Equipment/System Name \_\_\_\_\_

Part Number \_\_\_\_\_

Serial Number \_\_\_\_\_

Has the equipment been used, tested or operated ?

YES  Go to Section 2    NO  Go to Section 4

### IF APPLICABLE:

Tool Reference Number \_\_\_\_\_

Process \_\_\_\_\_

Failure Date \_\_\_\_\_

Serial Number of Replacement Equipment \_\_\_\_\_

## SECTION 2: SUBSTANCES IN CONTACT WITH THE EQUIPMENT

**Are any substances used or produced in the equipment:**

- Radioactive, biological or infectious agents, mercury, poly chlorinated biphenyls (PCBs), dioxins or sodium azide? (if YES, see Note 1) YES  NO
- Hazardous to human health and safety? YES  NO

**Note 1 :** BOC Edwards will not accept delivery of any equipment that is contaminated with radioactive substances, biological/infectious agents, mercury, PCB's, dioxins or sodium azide, unless you:

- Decontaminate the equipment
- Provide proof of decontamination

**YOU MUST CONTACT BOC EDWARDS FOR ADVICE BEFORE YOU RETURN SUCH EQUIPMENT**

## SECTION 3: LIST OF SUBSTANCES IN CONTACT WITH THE EQUIPMENT

Substance name	Chemical Symbol	Precautions required (for example, use protective gloves, etc.)	Action required after a spill, leak or exposure

## SECTION 4: RETURN INFORMATION

Reason for return and symptoms of malfunction \_\_\_\_\_

- If you have a warranty claim:
- who did you buy the equipment from ? \_\_\_\_\_
  - give the supplier's invoice number \_\_\_\_\_

## SECTION 5: DECLARATION

Print your name: \_\_\_\_\_ Print your job title: \_\_\_\_\_

Print your organisation: \_\_\_\_\_

Print your address: \_\_\_\_\_

Telephone number: \_\_\_\_\_ Date of equipment delivery: \_\_\_\_\_

I have made reasonable enquiry and I have supplied accurate information in this Declaration. I have not withheld any information, and I have followed the Return of BOC Edwards Equipment - Procedure (HS1).

**Note: Please print out this form, sign it and return the signed form as hard copy.**

Signed: \_\_\_\_\_ Date \_\_\_\_\_

This page intentionally blank.

## UNITED KINGDOM

### CORPORATE HEADQUARTERS

**BOC EDWARDS**  
Manor Royal  
Crawley  
West Sussex  
RH10 9LW  
Tel +(44) 1293 528844  
Fax +(44) 1293 533453

### BOC EDWARDS

Wingates Industrial Estate  
Great Bank Road  
Westhoughton, Bolton  
Lancashire  
BL5 3SL  
Tel +(44) 1942 652652  
Fax +(44) 1942 652651

## AMERICA (USA)

### USA HEADQUARTERS

**BOC EDWARDS**  
One Edwards Park  
301 Ballardvale Street  
Wilmington, MA 01887  
Tel +(1) 978 658 5410  
Toll free (USA only) 1 800 848 9800  
Fax +(1) 978 658 7969

3901 Burton Drive  
Santa Clara, CA 95054  
Tel +(1) 408 496 1177  
Fax +(1) 408 496 1188

1810 West Drake Drive  
Suite 101  
Tempe, AZ 85283  
Tel +(1) 480 777 7007  
Fax +(1) 480 777 2244

11701 Stonehollow Drive  
Suite 100  
Austin, TX 78758  
Tel +(1) 512 491 6622  
Fax +(1) 512 491 0629

3501 Island Avenue  
Philadelphia, PA 19153  
Tel +(1) 215 365 8653  
Fax +(1) 978 753 6846

## BELGIUM

**BOC EDWARDS**  
Bergensesteenweg 709  
B1600 Sint-Pieters-Leeuw  
Brussels  
Tel +(32) 2 363 0030  
Fax +(32) 2 363 0064

## BRAZIL

**BOC DO BRASIL LTDA**  
**DIVISÃO EDWARDS ALTO VACO**  
Rua Bernado Wrona 222  
02710 São Paulo-SP  
Tel +(55) 11 3952 5000  
Fax +(55) 11 3965 2766

## CANADA

**BOC EDWARDS**  
5975 Falbourne Street  
Mississauga, Ontario L5R3W6  
Canada  
Tel +(1) 905 501 2558  
Fax +(1) 905 501 1632

12055 Cote de Liesse  
Dorval, Quebec H9P1B4  
Canada  
Tel +(1) 514 631 3501  
Fax +(1) 514 631 3502

## CHINA

**BOC TRADING**  
**(SHANGHAI) CO. LTD.**  
23 Fu Te Road (N)  
Wai Gao Qiao Free Trade Zone  
Pudong  
Shanghai, 200131  
PRC China  
Tel +(86 21) 5866 9618  
Fax +(86 21) 5866 9993

## FRANCE

**BOC EDWARDS**  
125 Avenue Louis Roche  
92238 Gennevilliers, Cedex  
Paris  
Tel +(33) 1 47 98 24 01  
Fax +(33) 1 47 98 44 54

## GERMANY

**BOC EDWARDS**  
Ammerthalstraße 36  
85551 Kirchheim  
Munich  
Tel +(49) 89 99 19 18 0  
Fax +(49) 89 99 19 18 99

## HONG KONG S.A.R.

**BOC EDWARDS (ASIA)**  
12 Chun Yat Street  
Tseung Kwan O Industrial Estate  
Tseung Kwan O, Kowloon  
Hong Kong S.A.R.  
Tel +(852) 2372 2640  
Fax +(852) 2796 9095

## INDIA

**BOC EDWARDS**  
**DIVIN. OF BOC INDIA LIMITED**  
203 Surya Kiran Building  
19 Kasturba Gandhi Marg  
New Delhi - 110 001  
India  
Tel +(91) 11 851 0065  
Fax +(91) 11 851 0245

## ISRAEL

**EDWARDS ISRAEL VACUUM LTD.**  
5 Habarzel Blvd  
Gat 2000 Industrial Zone  
Qiryat Gat 82000  
Tel +(972) 8 681 0633  
Fax +(972) 8 681 0640

## ITALY

**BOC EDWARDS**  
Via Carpaccio 35  
20090 Trezzano sul Naviglio  
Milan  
Tel +(39) 02 48 4471  
Fax +(39) 02 48 401638

## JAPAN

**HEADQUARTERS**  
**BOC EDWARDS**  
Shuwa Shiba Park Building A-3F  
2-4-1 Shibakoen Minato-ku  
Tokyo, 105-0011  
Tel +(81) (0) 3 5470 6530  
Fax +(81) (0) 3 5470 6521

## KOREA

**HEADQUARTERS**  
**SONGWON EDWARDS LTD.**  
5th FL. Daewoo Engineering Bldg.  
Soonae-dong  
Bundang-gu, Sungnam City  
Kyungki-do, Korea  
Tel +(82) 31 716 7070  
Fax +(82) 31 738 1001-3

**FACTORY & GV**  
**SONGWON EDWARDS LTD.**  
625-7 Upsong-dong  
Chunan City  
Chungchong Nam-do  
Korea  
Tel +(82) 41 621 7070  
Fax +(82) 41 621 7700

## SINGAPORE

**BOC EDWARDS (ASIA)**  
42 Loyang Drive  
Loyang Industrial Estate  
Singapore 508962  
Tel +(65) 6546 8408  
Fax +(65) 6546 8407

## TAIWAN, R.O.C.

**EDWARDS TECHNOLOGIES**  
**LIMITED**  
No. 434 Chung hua Road  
Toufen Town, Miaoli County  
Taiwan ROC  
Tel +(886) 37 611422  
Fax +(886) 37 611401

**PLEASE CONTACT ANY OF THESE COMPANIES FOR DETAILS OF OTHER SALES AND SERVICE CENTRES IN YOUR AREA.**

BOC Edwards is part of BOC Limited. BOC Edwards and the stripe symbol are trade marks of The BOC Group.  
© BOC Edwards 2003

Produced by Technical Publicity Techpublicity@edwards.boc.com

<http://www.bocedwards.com>  
[info@bocedwards.com](mailto:info@bocedwards.com)

The logo for BOC Edwards, featuring a stylized red and white striped graphic to the left of the company name in a bold, red, sans-serif font.