

Ideal
 vacuum products
 (505) 872-0037
 2401 B Phoenix Ave. NE
 Albuquerque, NM 87107
idealtvac.com

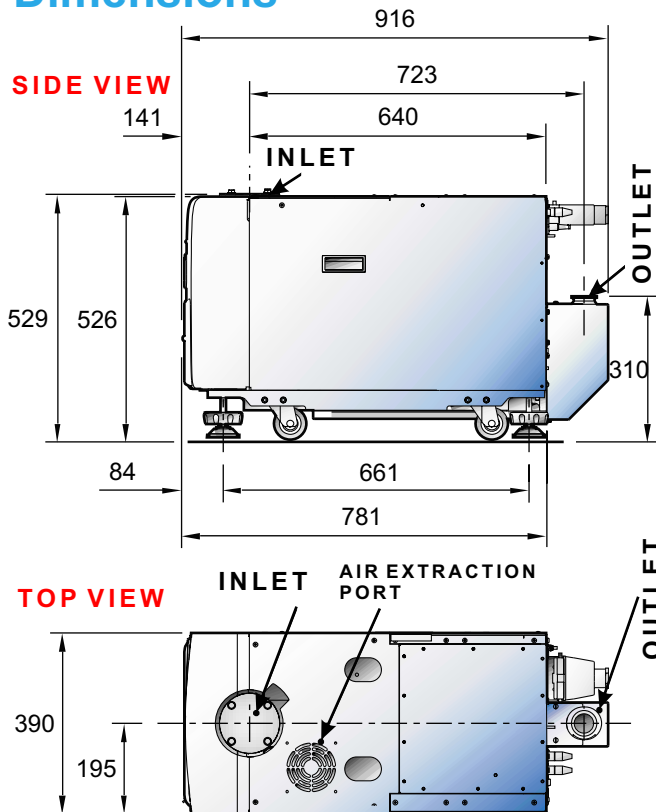

**Edwards iL70N
 Dimensions**



© Edwards Limited 2008. All rights reserved.



SPECIFICATIONS

| | | 60 Hz | 50 Hz |
|---|------------------------------------|----------------------------|----------------------------|
| Peak Speed | cfm | 49 | 41 |
| | M³h⁻¹ | 84 | 70 |
| | 1 min⁻¹ | 1400 | 1166 |
| Ultimate Vacuum (with shaft seal purge) | torr | 2.3X10⁻² | 3.8X10⁻² |
| | mbar | 3X10 ⁻² | 5X10 ⁻² |
| | Pa | 3 | 5 |
| Typical Shaft Seal nitrogen flow | slm | 4 | 4 |
| Inlet Connection | | ISO63 | |
| Outlet Connection | | NW40 | |
| Typical cooling water flow at 15psi drop | 1 h⁻¹ | 90 | |
| | 1 min⁻¹ | 1.5 | |
| Weight | kg/lbs. | 230/506 | |
| Power input | kW | 1.5 | 1.3 |
| Rated motor | kW | 2.2 | 1.8 |
| Oil Capacity | liter | 0.75 | |

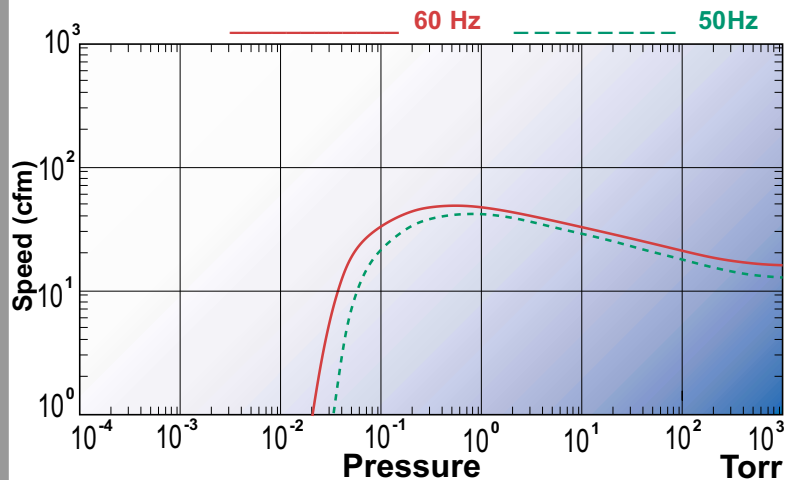

iL70N Pumping Speed Curve

**90 DAY WARRANTY
 ON ALL PARTS & LABOR**