

60HZ 50HZ  
**CFM 106 88**

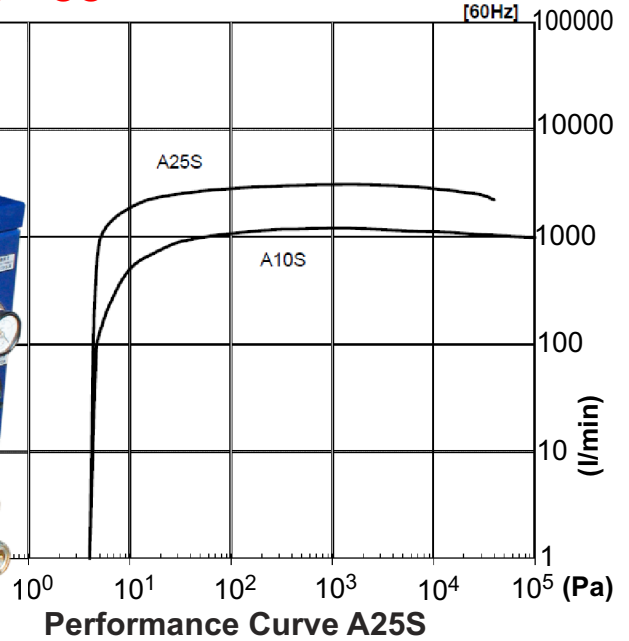

# A25S

## MULTI-STAGE DRY PUMP

### EBARA A25S Specifications

Pumping speed (N2) 50/60 Hz	l/min.	2500/3000
Pumping speed (N2) 50/60 Hz	m <sup>3</sup> /h	150/180= <b>CFM 88/106</b>
Ultimate pressure 50/60 Hz	mbar	5x10 <sup>-2</sup> , 4x10 <sup>-2</sup>
Ultimate pressure 50/60 Hz	Pa	5.3/4.0
Water Consumption	l/min.	3.5
Nitrogen Consumption	SLM	10-12
Nitrogen Consumption	Pa m <sup>3</sup> /sec	17-20
Voltages ranges	V	200-220/380-415
Motor power, installed	kW	3.7
Weight, approx.	kg/lbs.	240/528
Sizes (LxWxH)	mm	900x394x470
Inlet flange size		DN 40 KF
Outlet flange size		DN 40 KF

### Technical Characteristics

- Complete pump safeguard system
- High pump operating temperature preventing condensation
- Low noise and low vibration
- Corrosion resistant materials-stainless steel coolers, water circuits
- High reliability even for harsh processes
- Efficient interstage coolers for LPCVD nitride process
- Canned motor
- Low service requirements
- Control panel for monitoring operating conditions

### Customer Benefits

- Very low nitrogen consumption for purging
- Clean room compatible
- Low service requirements
- Compact size and small footprint

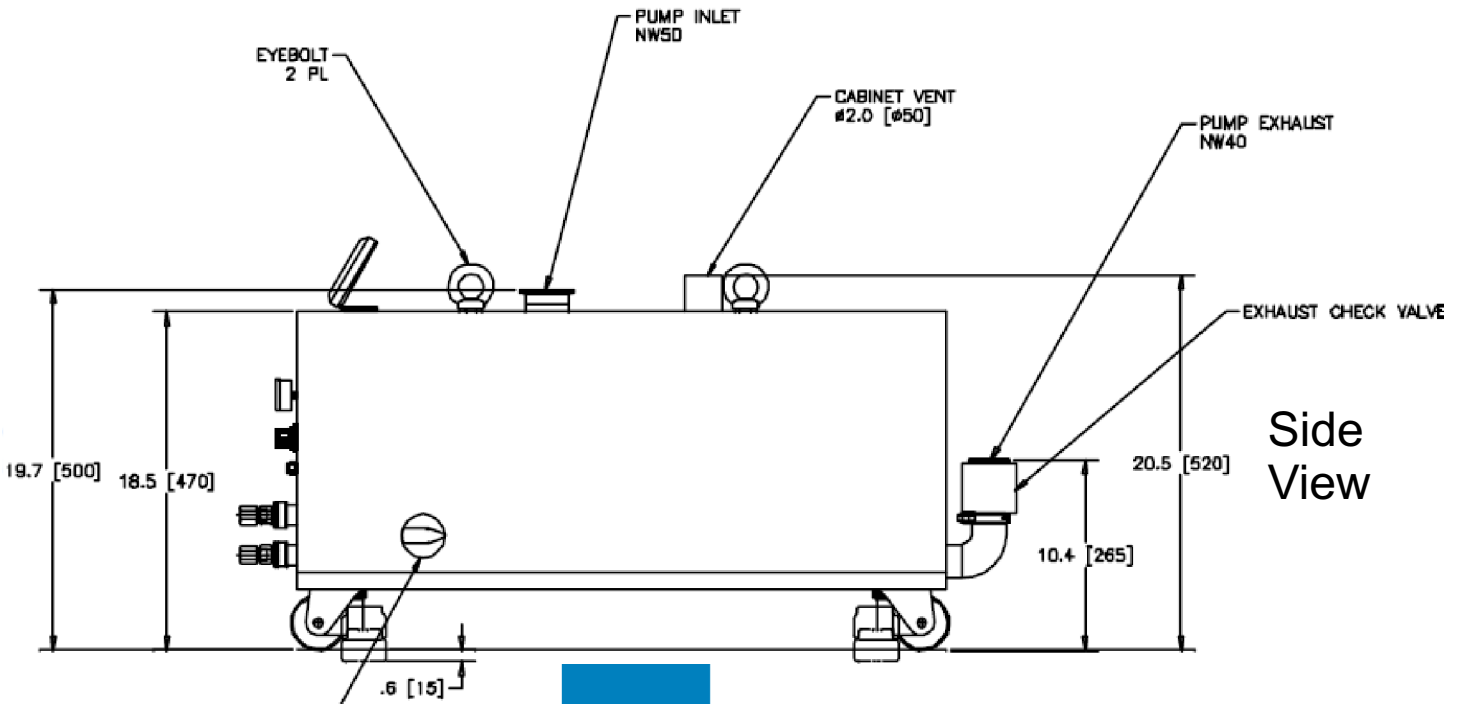

**A25S**  
**MULTI-STAGE DRY PUMP**

