



9600 (High Voltage) Compressor
Installation, Operation and
Maintenance Manual

Information provided within this document is subject to change without notice, and although believed to be accurate, Brooks Automation assumes no responsibility for any errors, omissions, or inaccuracies.

AcuLigner™, Align™, AquaTran™, AutoTeach™, ATR™, AXM™, Basic Blue™, BiSymmetrik™, CenterSmart™, Cool Solutions™, Crate to Operate™, e-RMA™, e-Spares™, e-Volution™, FastRegen™, FIXLOAD™, FrogLeg™, InLigner™, InCooler™, Interface™, Jet Engine™, LowProfile™, M2 Nano™, Mini-Ion™, PASIV™, PowerPak™, PerformanceBlue™, PowerPak™, PowerTools™, QuadraFly™, Radius™, Radiant™, Radiant Express™, Reliance™, Reliance ATR™, RetroEase™, SCARA™, SmartPM™, SPOTLevel™, Synetics™, The New Pathway to Productivity™, Time Optimized Trajectory™, Time Optimal Trajectory™, Time Optimized Path™, TopCooler™, TopLigner™, Ultimate Blue™, VAC-407™, VacuTran™, Vacuum Quality Monitor™, VQM™, Vacuum Quality Index™, VQI™, and the Brooks logo are trademarks of Brooks Automation, Inc.

AcuTran®, AquaTrap®, Conductron®, Convector®, the Cool Solutions logo, Cryodyne®, Cryotiger®, Cryo-Torr®, Fusion®, GOLDLink®, Granville-Phillips®, Guardian®, GUTS®, Helix®, Jet®, Leapfrog®, MagnaTran®, MapTrak®, Marathon®, Marathon 2®, Marathon Express®, Micro-Ion®, MiniConvector®, On-Board®, Polycold®, Razor®, Simplicity Solutions®, the Simplicity Solutions logo, Stabil-Ion®, TrueBlue®, TurboPlus®, Vision®, Zaris®, and the Brooks Automation logo are registered U.S. trademarks of Brooks Automation, Inc.

All other trademarks are properties of their respective owners.

© 2013 Brooks Automation, Inc. All Rights Reserved. The information included in this manual is Proprietary Information of Brooks Automation and is provided for the use of Brooks Automation customers only and cannot be used for distribution, reproduction, or sale without the express written permission of Brooks Automation. This information may be incorporated into the user's documentation, however any changes made by the user to this information is the responsibility of the user.



For Technical Support:

Location	GUTS® Contact Number
North America	+1-800-FOR-GUTS (1-800-367-4887) +1-978-262-2900
Europe	+49-1804-CALL-GUTS (+49-1804-2255-4887)
Japan	+81-45-477-5980
China	+86-21-5131-7066
Taiwan	+886-3-5525225
Korea	+82-31-288-2500
Singapore	+65-6464-1481

Visit us online: www.brooks.com

January 10, 2013 Part Num 8040437 Revision AA

This technology is subject to United States export Administration Regulations and authorized to the destination only; diversion contrary to U.S. law is prohibited.

Printed in the U.S.A.

Table of Contents

Table of Contents

Figures

Tables

Safety Conventions

Introduction	S-1
Signal Word Descriptions	S-1
Safety Shape Descriptions	S-2
References	S-2

Section 1 - 9600 Compressor Description

General	1-1
Compressor Configurations	1-1
System Documentation	1-1
BROOKS-CRYOGENICS Helium Refrigeration System	1-1
Specifications	1-4
Dimensions	1-4
Weight	1-5
Electrical	1-5
Cooling Water	1-5
General	1-6
Component Description	1-8
System Circuit Breaker	1-9
Elapsed Time Meter	1-9
Control Circuit Breaker	1-9
Power ON Indicator	1-9
Gas Charge Flared Fitting	1-9
Helium Pressure Gauge	1-10
Power Inlet	1-10
Return Gas Coupling	1-10
Cooling Water IN	1-10
Cooling Water OUT	1-10
Cryopump Electrical Outlet	1-10
Compressor Remote Connector	1-11
Supply Gas Coupling	1-11

Multiple On-Board Cryopump Connections	1-12
Multiple Cryo-Torr Cryopump Connections	1-13

Section 2 - Unpacking and Inspection

Introduction	2-1
Shipping Carton Inspection	2-1
Removal from Shipping Carton	2-1
Compressor Inspection	2-2
Compressor	2-2
Helium "OFF" Condition Pressure Verification	2-2
Shipping Carton Contents	2-2

Section 3 - Installation

Introduction	3-1
Supply and Return Water Line Connections	3-3
Hard Water Lines	3-3
Flexible Water Lines	3-3
Electrical Connections	3-4
Phase Check	3-6
Connecting/Disconnecting Helium Flex Lines	3-7
Connecting	3-7
Disconnecting	3-7
Single On-Board Cryopump Connections	3-8
Multiple On-Board Cryopump Connections	3-11
Helium Line Connections	3-11
Power Cable Connections	3-12
Multiple Cryo-Torr Cryopump Connections	3-14
Helium Line Connections	3-14
Power Cable Connections	3-14

Section 4 - Operation

Adjusting System Helium Pressure	4-1
"OFF" Condition Helium System Pressure Verification	4-1
Compressor Operation	4-2
Replacement of Helium Circuit Components	4-3

Section 5 - Maintenance

Scheduled Maintenance	5-1
Suggested Maintenance Equipment	5-1
Adsorber Replacement	5-2
Adjusting System Helium Pressure	5-5
Reducing Helium Pressure	5-5

Increasing Helium Pressure	5-6
Adding Helium	5-6

Appendix A: Customer Brooks Automation Technical Support Information

Appendix B - Flow Diagram

Appendix C - Troubleshooting Procedures

Troubleshooting the Compressor	C-1
Technical Inquiries	C-1

Appendix D - Schematic

Introduction	D-1
--------------------	-----

Index

This Page Intentionally Left Blank

Figures

Figure 1-1: 9600 Compressor	1-3
Figure 1-2: 9600 Compressor Dimensions	1-4
Figure 1-3: Water Flow Rate versus Pressure Drop	1-6
Figure 1-4: 9600 Compressor Rear View Component Locations.	1-8
Figure 1-5: 9600 Compressor Connected to Multiple On-Board Cryopumps	1-12
Figure 1-6: 9600 Compressor Connected to Multiple Cryo-Torr Cryopumps	1-13
Figure 3-1: 9600 Compressor Installation Flowchart	3-2
Figure 3-2: 9600 Compressor Circuit Breaker Terminals (Cover Removed) .	3-5
Figure 3-3: Connecting/Disconnecting Helium Flex Line Couplings	3-8
Figure 3-4: Single On-Board Cryopump Connections	3-9
Figure 3-5: Single Cryo-Torr Cryopump Installation.	3-10
Figure 3-6: Recommended Multiple On-Board Cryopump or Waterpump Installation (Splitter Box located at Process Tool)	3-12
Figure 3-7: Alternative Multiple On-Board Cryopump or Waterpump Installation (Splitter Box located at Compressor)	3-13
Figure 3-8: Multiple Cryo-Torr Cryopump Installation	3-15
Figure 3-9: Multiple Cryo-Torr Cryopump Installation	3-16
Figure 5-1: Disconnecting Self Sealing Couplings.	5-2
Figure 5-2: Adsorber Location in 9600 Compressor (Rear Panel Removed). .	5-4
Figure 5-3: Helium Pressure Control Components.	5-5
Figure B-1: 9600 Compressor Flow Diagram P/N 8135001 Rev. A	B-2
Figure D-1: 9600 High Voltage Compressor	D-4

Tables

Table 1-1:Compressor Weight	1-5
Table 1-2:Electrical Input Specifications	1-5
Table 1-3:Cooling Water Specifications.	1-5
Table 1-4:General Compressor Operating Specifications	1-7
Table 1-5:Cryopump Electrical Outlet Pin Assignments	1-11
Table 1-6:Compressor Remote Connector Pin Assignments	1-11
Table 4-1:9600 Compressor Helium ("OFF" Condition) Charge.	4-1
Table 5-1:Suggested Maintenance Equipment	5-1
Table C-1:Compressor Troubleshooting Procedures	C-2
Table D-1:Basic Control Assembly Legend.	D-1
Table D-2:On-Board/Cryo Electrical Module P/N 8135127G002 Legend	D-2
Table D-3:On-Board Output Module P/N 8135148G001 Legend	D-3

Safety Conventions

Introduction



Follow all safety precautions during installation, normal operation, and when servicing BROOKS-Cryogenics products.

This chapter explains the safety conventions used throughout this manual. BROOKS-Cryogenics uses a specific format for cautions and warnings, which includes standard signal words and safety shapes.

See also the *Customer Support* appendix or call your local Customer Support Center for assistance.



Signal Word Descriptions

All cautions and warnings contain signal words, which call attention to safety messages and designate the degree of hazard seriousness. The following table shows the signal words and their meanings that may be used in this document.

Term	Example	Definition
CAUTION		A signal word accompanied by a safety shape that indicates a potentially hazardous situation or unsafe practice. If not avoided, the action may result in minor or moderate personal injury or equipment damage . A CAUTION is highlighted in yellow.
CAUTION		A signal word that indicates a situation or unsafe practice, which if not avoided may result in equipment damage . A CAUTION is highlighted in yellow.
WARNING		A signal word accompanied by a safety shape that indicates indicates a potentially hazardous situation. If not avoided, the action may result in serious injury or death . A WARNING is highlighted in orange.

Safety Shape Descriptions

All cautions and warnings contain safety shapes, which have specific safety meanings. The following table shows some of the safety shapes used in this document and their meanings.

Example	Term	Shape Definition
	General Warning	Indicates a general hazard. Details about this hazard appear in the safety notice explanation.
	High Voltage	Indicates a high voltage hazard.
	Hot Surface	Indicates a surface is hot enough to cause discomfort or a burn.

References

For more information about safety standards, see the following documents:

- ISO 7010: 2003(E), Graphic symbols - Safety colours and safety signs - Safety signs used in workplaces and public areas
- ISO 3864-1: 2002(E), Graphic symbols - Safety colours and safety signs - Part 1: Design principles for safety signs in workplaces and public areas

Section 1 - 9600 Compressor Description

General

This manual provides the information required to install, operate, and maintain the BROOKS-CRYOGENICS 9600 Compressor.

***NOTE:** All personnel with installation, operation, and maintenance responsibilities should become familiar with the contents of both the 9600 Compressor Installation, Operation, Maintenance, and appropriate cryopump manuals to ensure safe, high quality, and reliable system performance.*



CAUTION

Refer to “[Appendix A: Customer Brooks Automation Technical Support Information](#)” to contact the local Customer Support Center for information on connecting 9600 Compressors to a manifold with other BROOKS-CRYOGENICS compressors.

Compressor Configurations

The 9600 Compressor supports either On-Board or Cryo-Torr Cryopumps. For multiple cryopump installations, an On-Board Splitter Box or Cryo-Torr Interface can be used for cold head power distribution that reduces total cable requirements as shown in [Figure 1-5](#) and [Figure 1-6](#).

System Documentation

The manuals for a *system* cover two basic components: the cryopump and the Compressor. A manual is shipped with each system component to provide information for installation and operation of that component. A loose-leaf binder with index tab separators is also provided so you can compile a complete set of tabulated manuals.

BROOKS-CRYOGENICS Helium Refrigeration System

The operation of BROOKS-CRYOGENICS’ cryopumps is based upon a closed loop helium expansion cycle. The *system* is made up of two major

components: the cryopump, which contains the cold head, and the helium Compressor which compresses the helium gas.

Refrigeration is produced in the cryopump cold head through periodic expansion of high pressure helium in a regenerative process. The high pressure helium is provided by the Compressor. Low pressure helium returning from the cold head is compressed into the necessary high pressure to be returned to the cold head. The energy required to compress the helium is rejected as heat through the cooling water.

High pressure room temperature helium is transferred to the cold head through the supply lines. After expansion, low pressure helium is returned to the Compressor (at or near room temperature) to repeat the cycle in a closed loop fashion. Large separation distances can be accommodated between the Compressor and the cryopump.

In the Compressor, helium is compressed using a highly reliable oil lubricated commercial Compressor. Helium purification takes place via several stages of oil removal. The final stage of purification is performed with a replaceable adsorber cartridge. In order to maintain peak efficiency, the adsorber must be replaced every three years. The 9600 Compressor is shown in [Figure 1-1](#).

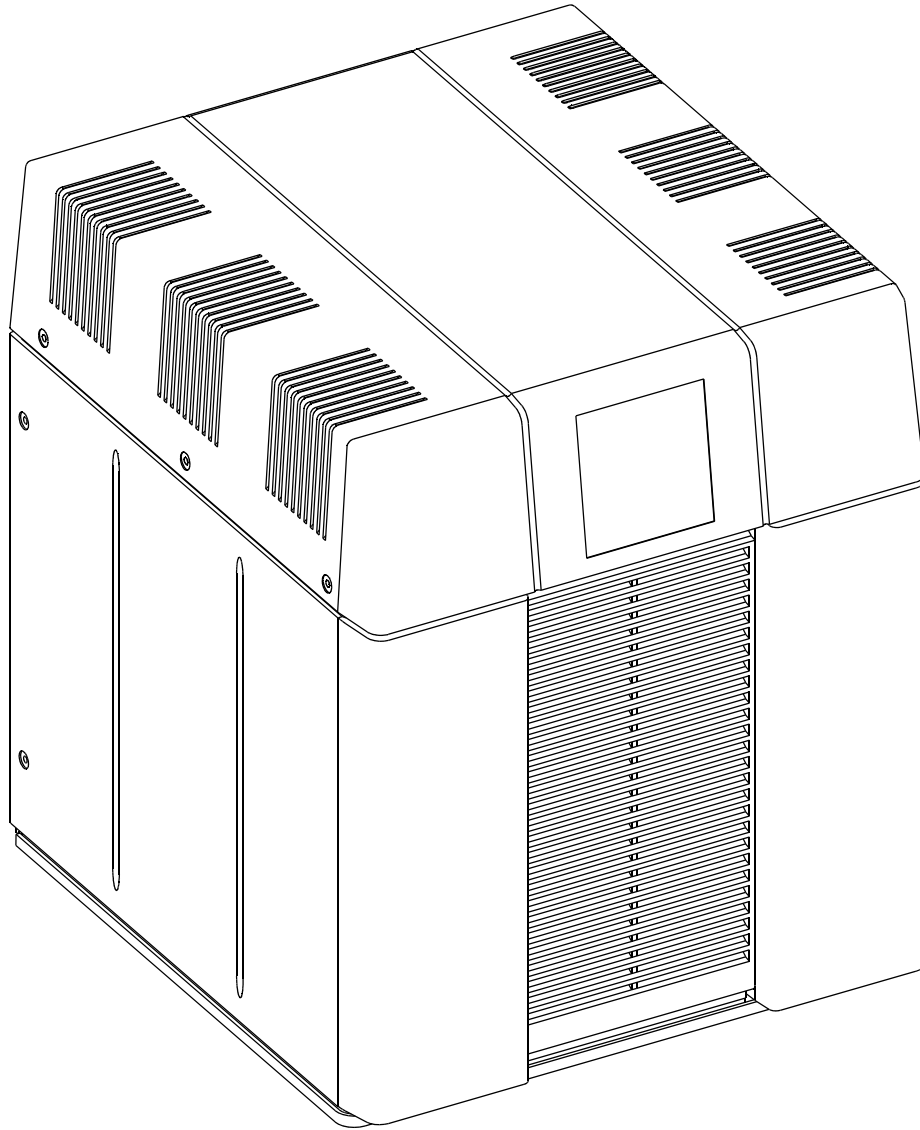

Figure 1-1: 9600 Compressor

Specifications

Dimensions

The dimensions of the Compressor are shown in [Figure 1-2](#).

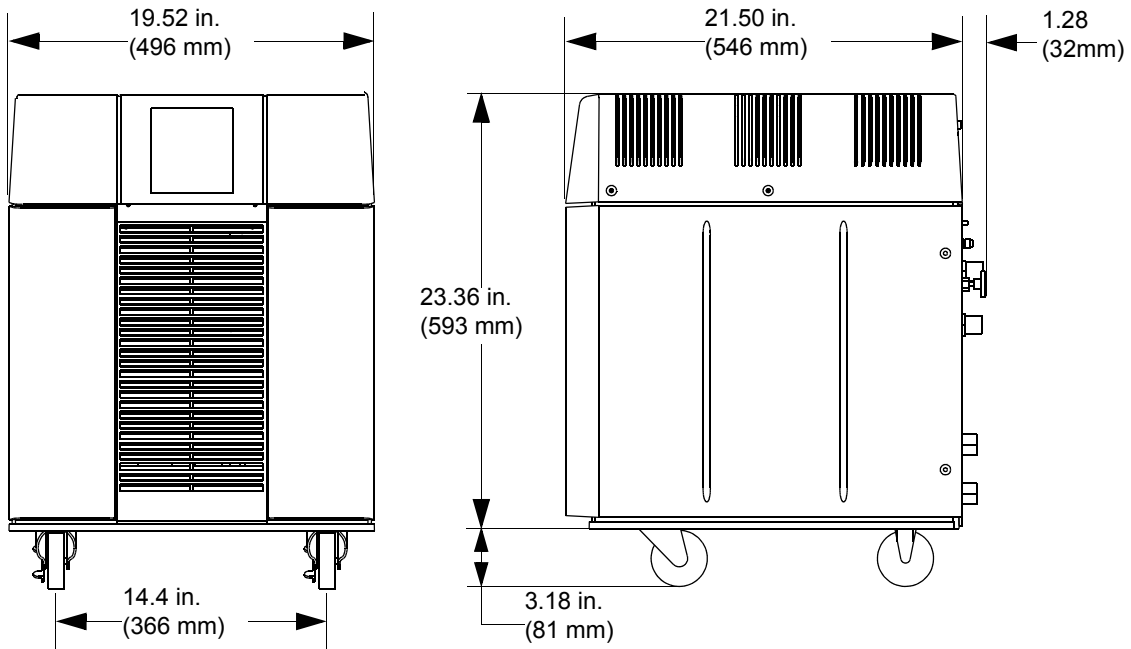

Figure 1-2: 9600 Compressor Dimensions

CAUTION

Do not place a weight greater than 75 lbs. (34Kg) on top of the Compressor.

Weight

The weight of the Compressor is listed in [Table 1-1](#).

Table 1-1: Compressor Weight

Weight lbs./kg
267/121kg

Electrical

The electrical specifications of the Compressor are listed in [Table 1-2](#).

Table 1-2: Electrical Input Specifications

Parameter	Value
Operating Voltage Range/Frequency	342-457V/50 Hz 342-506V/60 Hz
Phase	3
Nominal Input Power	5.5 KW/60 Hz 5KW/50 Hz
Nominal Power Factor	0.85
Rated FL/LR* Current	8/40
Minimum Electrical Service	15 Amps
*FL/LR = Full Load/Locked Rotor	

Cooling Water

The water used to cool the Compressor must meet the specifications shown in [Table 1-3](#) for proper system operation.

Table 1-3: Cooling Water Specifications

Parameter	Value
Maximum Inlet Temperature	90°F (32°C)
Minimum Inlet Temperature	50°F (10°C)
Flow Rate	2.75 ±1.25 gpm (10.4 ± 4.7 lpm)
NOTE: Water conditioning may be required for applications not meeting these requirements.	

Table 1-3: Cooling Water Specifications (Continued)

Parameter	Value
Pressure Drop (inlet-to-outlet)	See Figure 1-3
Maximum Inlet Pressure	100 psi (6.9 bars)
Alkalinity	6.0 - 8.0 pH
Calcium Carbonate	< 75 ppm

NOTE: Water conditioning may be required for applications not meeting these requirements.

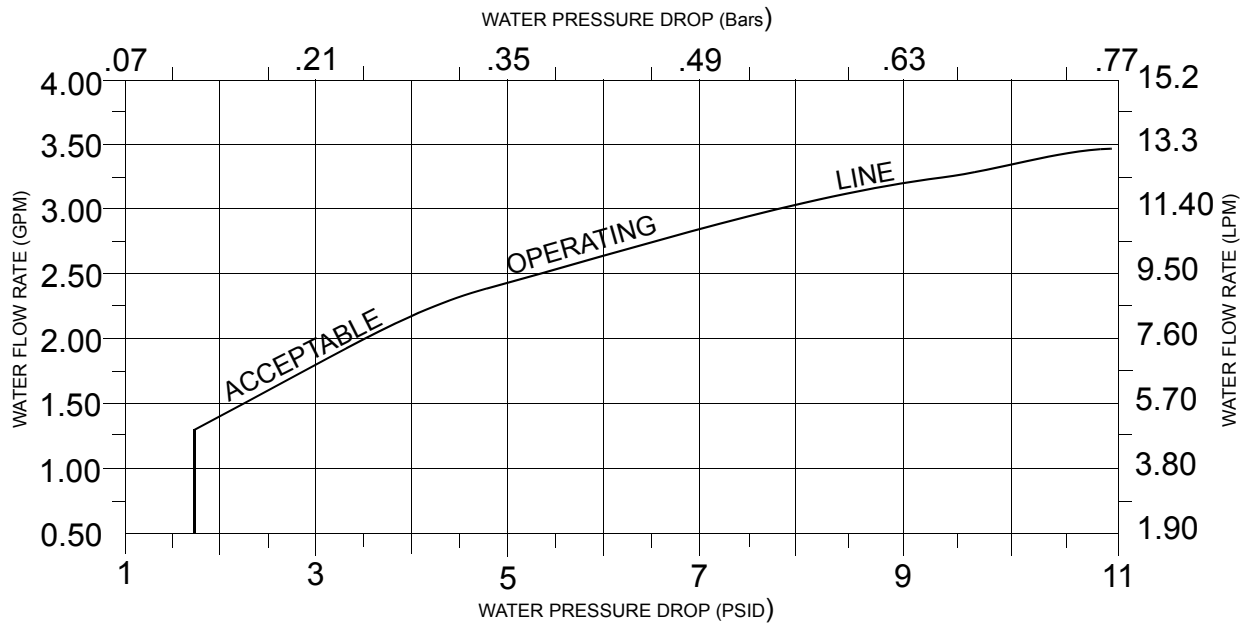

NOTE: [Figure 1-3](#) defines the water flow rate through the Compressor as a function of the pressure drop from water inlet to water outlet. You must provide the correct pressure drop in your water supply system to ensure that the water flow condition meets the requirements specified in [Table 1-3](#).

Figure 1-3: Water Flow Rate versus Pressure Drop

General

The information in [Table 1-4](#) provides general Compressor operating specifications.

Table 1-4: General Compressor Operating Specifications

Specification	Values
Part Number	8135901G001
Input Power Cable (Customer Supplied)	600 VAC 12 Gauge, 3 conductor wire with ground Must conform to local electrical codes
Nominal Helium Pressure	Refer to Table 4-1
Ambient Operating Temperature Range	50 - 100° F (10 - 38° C)
Interface	Cryopump Power Receptacles: mates with the BROOKS-CRYOGENICS supplied cryopump power cable for single pump use. Mates with remote junction box power cable for multiple cryopump use.
Gas Supply Connector	1/2 in. Aeroquip self-sealing coupling
Gas Return Connector	1/2 in. Aeroquip self-sealing coupling
Remote Control Receptacle	24VAC, 2.7A inductive mates with P5 connector Type MS3106A*
Adsorber Service Schedule	3 Years
* Supplied by BROOKS-CRYOGENICS	

NOTE: The 9600 Compressor is designed for continuous operation and should remain ON when the cryopumps are in a regeneration cycle.

Component Description

The components of the 9600 Compressor that are accessible from the rear panel are shown in [Figure 1-4](#) and described in the following paragraphs.

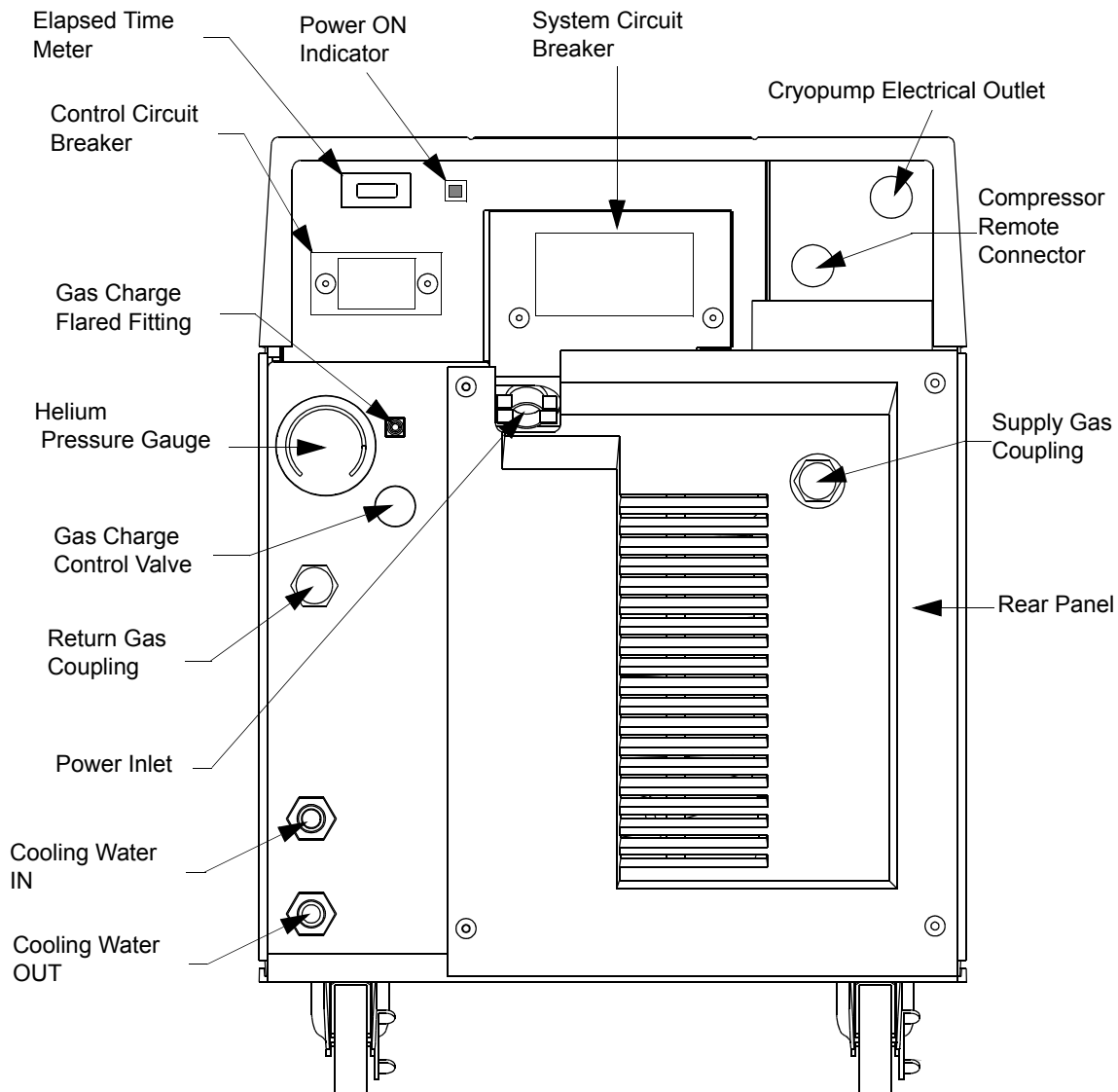

Figure 1-4: 9600 Compressor Rear View Component Locations

System Circuit Breaker

The System Circuit Breaker protects main input power to the Compressor pump and module. The circuit breaker positions are labeled ON (1), which is in the UP position, and OFF (0), which is in the DOWN position.

***NOTE:** The phase monitor in the Compressor will cause the system circuit breaker to open when input power phases are incorrect.*

Elapsed Time Meter

The Elapsed Time Meter records the number of Compressor operating hours. Since the meter is digital, it is not illuminated unless the system circuit breaker is in the ON position and power is connected to the Compressor. The Elapsed Time Meter maintains the correct accumulated operating hours while system power is turned OFF.

***NOTE:** The meter cannot be reset.*

Control Circuit Breaker

The Control Circuit Breaker provides current overload protection for all internal components of the Compressor except the Compressor motor. The Compressor motor is protected by a separate overload protector. The Control Circuit Breaker opens automatically and must be reset manually.

Power ON Indicator

The Power On Indicator illuminates when the system circuit breaker is placed in the ON position. The Compressor pump is energized when the power indicator is illuminated and the elapsed time meter records system operation time.

Gas Charge Flared Fitting

The Gas Charge Flared Fitting is used to connect a 99.999% pure helium supply to the Compressor when helium charging is required. The fitting has a 45° flare and 7/16 in. x 20 threads/inch. Refer to [“Section 5 - Maintenance”](#) for information on adding helium to the Compressor.

Helium Pressure Gauge

The Helium Pressure Gauge indicates system ("OFF" Condition) helium charge pressure when the Compressor and cryopumps are OFF and Compressor suction or inlet pressure when the Compressor is ON. Refer to [Table 4-1](#) for the appropriate ("OFF" Condition) helium charge pressure.

Power Inlet

The Power Inlet is used to connect your power cable to the Compressor. Refer to ["Section 3 - Installation"](#) for information on power cable installation.

Return Gas Coupling

The Return Gas Coupling returns the helium, which has been cycled through the cryopump, back to the Compressor. Refer to ["BROOKS-CRYOGENICS Helium Refrigeration System"](#) in this section for more information.

Cooling Water IN

The Cooling Water IN connector provides water to the Compressor from your facility to cool the Compressor during operation. The connector thread size is a 1/2 in. female pipe thread. The water must meet the specifications outlined in [Table 1-3](#). Refer to ["Section 3 - Installation"](#) for more information on cooling water connections.

Cooling Water OUT

The Cooling Water OUT connector returns the water that has been used to cool the Compressor to your facility. The connector thread size is a 1/2 in. female pipe thread. Refer to ["Section 3 - Installation"](#) for more information on cooling water connections.

Cryopump Electrical Outlet

The Cryopump Electrical Outlet provides power to a single On-Board or Cryo-Torr Cryopump, an On-Board Splitter Box, or a Cryo-Torr Interface. The Compressor requires the use of an On-Board Splitter Box or Cryo-Torr Interface for multiple cryopump system connections. Refer to [Table 1-5](#) for connector pin identification. Refer to ["Multiple On-Board Cryopump Connections"](#) or ["Multiple Cryo-Torr Cryopump Connections"](#) in this

section for more information.

Table 1-5: Cryopump Electrical Outlet Pin Assignments

Identifier	Function
A and B	Heater Power - 208 VAC nominal
C	Center tap for D and E
D and E	24 VCT @ 4.6 Amps
F-G and G-H	Cold Head Voltage Output 130-160 VAC @ 4.5 Amps
J	Chassis Ground
K	Not Used

Compressor Remote Connector

The Compressor Remote Connector is a 14 pin connector that can be used in conjunction with the On-Board setpoint relays, relays in the Cryo-Torr Interface, or a signal from the vacuum system to turn the Compressor ON or OFF. Refer to [Table 1-6](#) for connector pin identification. Switching contacts must be rated at 24VAC, 2.7A inductive.

***NOTE:** The Compressor is shipped with a mating plug which must remain installed in the Compressor Remote Connector to ensure Compressor operation when the Compressor remote feature is not being used.*

Table 1-6: Compressor Remote Connector Pin Assignments

Identifier	Function
D and E	Compressor Remote Control Make = ON, Break = OFF
F, G, I, J	Answer Back
A,B,C,H,K,L,M,N	Open

Supply Gas Coupling

The Supply Gas Coupling provides a connection for high pressure compressed helium to the cryopump cold head. Refer to [“BROOKS-CRYOGENICS Helium Refrigeration System”](#) in this section for more information.

Multiple On-Board Cryopump Connections

The On-Board Splitter Box permits the connection of multiple On-Board Cryopumps or Waterpumps to one 9600 Compressor as shown in [Figure 1-5](#). Refer to “[Section 3 - Installation](#)” for more information on connecting single or multiple On-Board Cryopumps or Waterpumps to the Compressor.

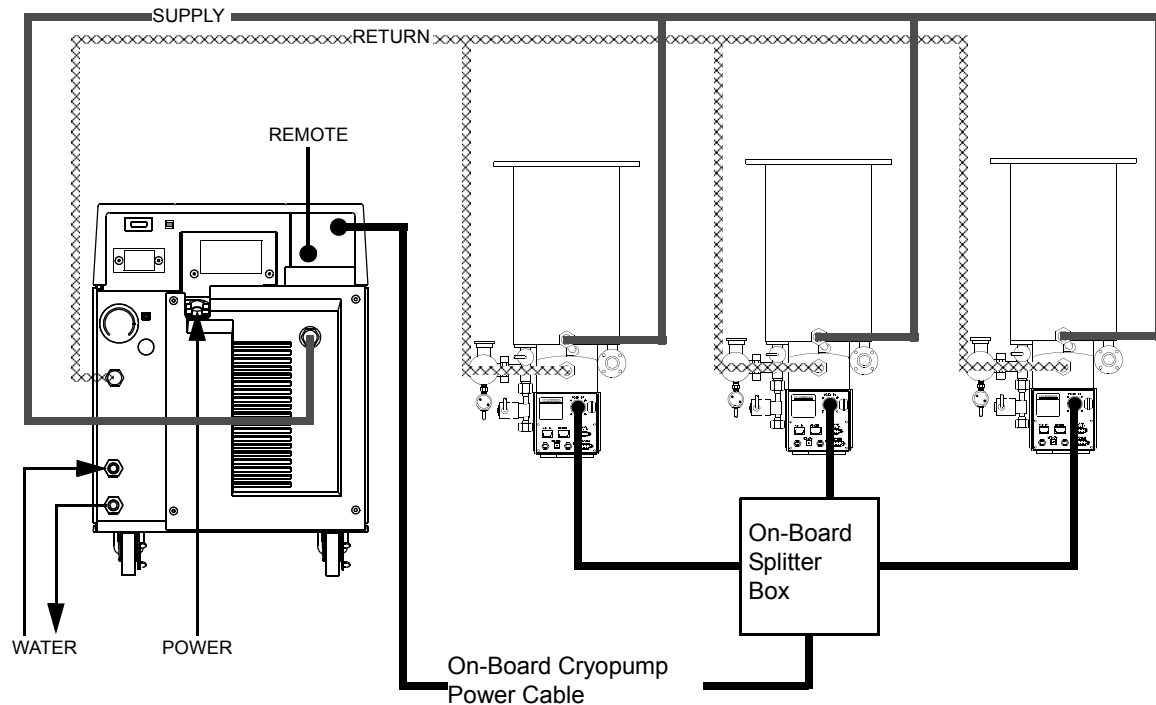

Figure 1-5: 9600 Compressor Connected to Multiple On-Board Cryopumps

NOTE: Your installation (number of pumps per compressor) will vary based upon the On-Board Cryopumps or Waterpumps used. Refer to “[Appendix A: Customer Brooks Automation Technical Support Information](#)” to consult your local BROOKS-CRYOGENICS Customer Support Center for information on specific compressor/pump applications.

Multiple Cryo-Torr Cryopump Connections

The Cryo-Torr Interface permits the connection of multiple Cryo-Torr Cryopumps to one Compressor as shown in [Figure 1-6](#).

Refer to “[Section 3 - Installation](#)” for more information on connecting single or multiple Cryo-Torr Cryopumps to the Compressor.

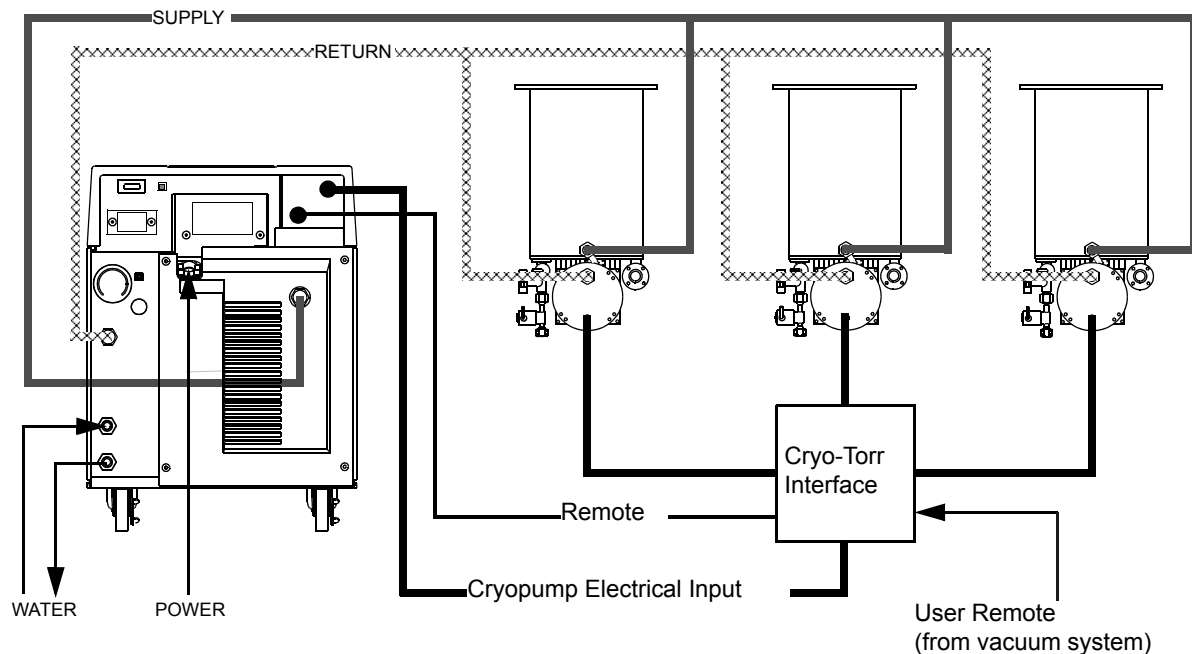

Figure 1-6: 9600 Compressor Connected to Multiple Cryo-Torr Cryopumps

***NOTE:** Your installation (number of pumps per compressor) will vary based upon the Cryo-Torr Cryopump models used. Refer to “[Appendix A: Customer Brooks Automation Technical Support Information](#)” to consult your local BROOKS-CRYOGENICS Customer Support Center for information on specific compressor/cryopump applications.*

This Page Intentionally Left Blank

Section 2 - Unpacking and Inspection

Introduction

The 9600 Compressor is shipped in a shipping carton incorporating a ramp system which makes removing the Compressor from the carton safe and easy.

Shipping Carton Inspection

Inspect the exterior of the shipping carton for visible signs of damage before opening the shipping carton. Report any damage to the shipping company at once.

Removal from Shipping Carton

1. Cut the two straps on the exterior of the shipping pallet.
2. Lift the cardboard carton straight up and remove it from the pallet.
3. Cut the tape which holds the ramp in the vertical position.
4. Swing the ramp down until the end touches the floor.
5. Remove any excess shipping material from around the Compressor.

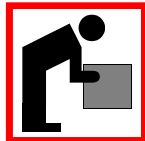

Maintain control over the movement of the Compressor as it rolls down the ramp. Injury to personnel may result if the Compressor is allowed to roll freely down the ramp.

CAUTION

Maintain control over the movement of the Compressor as it rolls down the ramp. Damage to the Compressor may result if the Compressor is allowed to roll freely down the ramp.

6. Carefully roll the Compressor down the ramp and onto the floor.

Compressor Inspection

Inspect the Compressor for visible signs of damage as indicated in the following paragraphs.

Compressor

Inspect the exterior of the Compressor for visible signs of damage, evidence of an oil leak, and check the Helium Pressure Gauge for proper helium pressure. Report any damage to the shipping company at once.

Helium "OFF" Condition Pressure Verification

Refer to "[Section 4 - Operation](#)" for more information on the ("OFF" Condition) helium charge pressure of the 9600 Compressor.

Shipping Carton Contents

The shipping carton should contain the following items:

- Compressor
- Two barbed fittings for flexible water lines
- Installation, Operation, and Maintenance manual
- Compressor remote start connector and strain relief

Section 3 - Installation

Introduction

Section 3 provides you with the information required to install the 9600 Compressor and connect it to single or multiple On-Board or Cryo-Torr Cryopump configurations.

[Figure 3-1](#) highlights the major tasks for Compressor installation and refers to the appropriate installation procedures in this section.

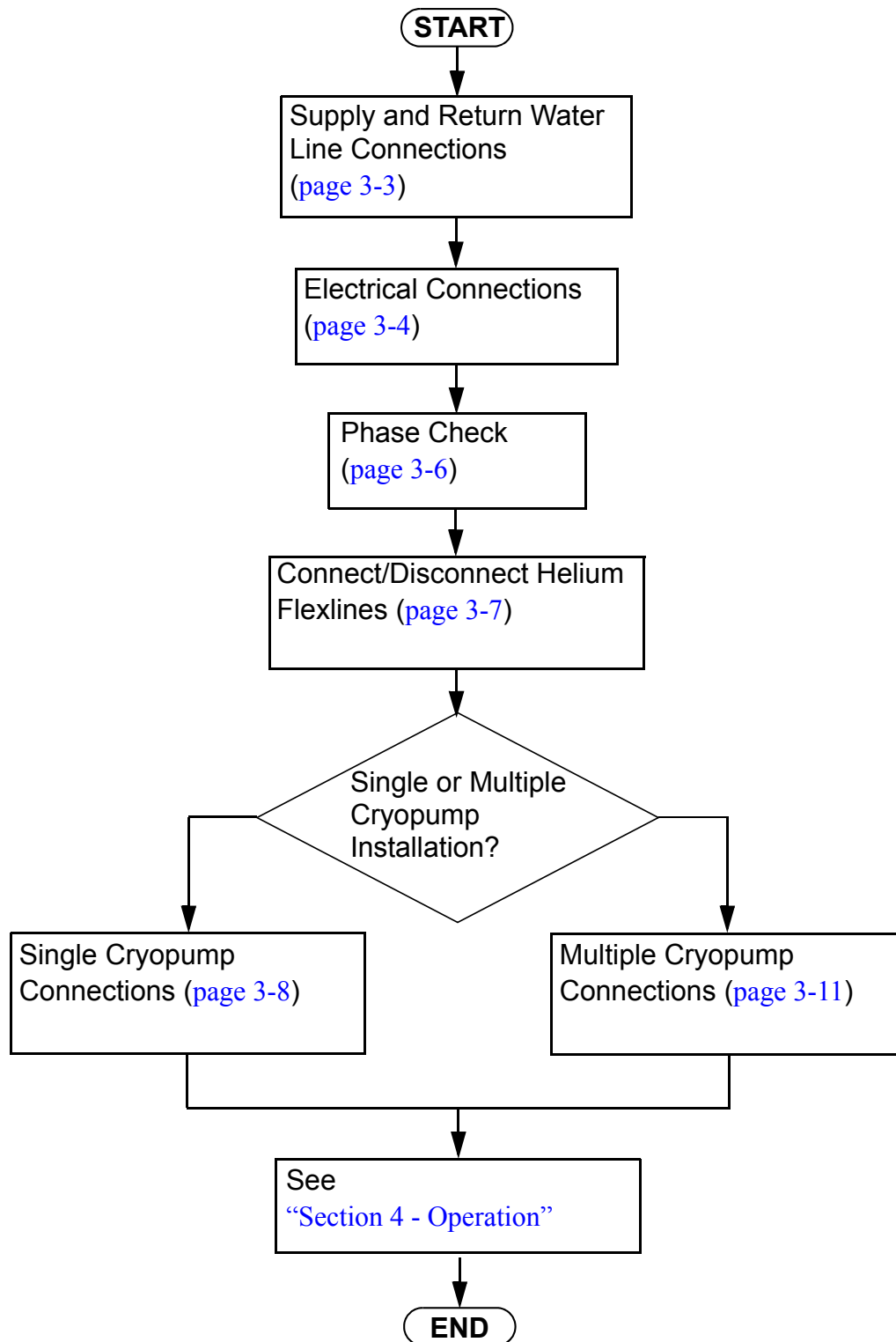

Figure 3-1: 9600 Compressor Installation Flowchart

Supply and Return Water Line Connections

***NOTE:** The water used for cooling the Compressor must meet the specifications outlined in “Section 1 - 9600 Compressor Description”.*

Hard Water Lines

1. Apply a light coating of standard plumbing thread sealant to the hard line pipe threads.
2. Install the Supply hard line into the INPUT connection on the rear panel of the Compressor. Tighten the fitting by hand.
3. Install the Return hard line into the OUTPUT connection on the rear panel of the Compressor. Tighten the fitting by hand.

CAUTION

Do not overtighten the ferrules. Damage to the input and output connector threads may occur.

4. Using a wrench, tighten the fittings.
5. Allow water to flow and check for leaks at the rear of the Compressor.

Flexible Water Lines

1. Apply a light coating of standard plumbing thread sealant to the barbed fitting threads.
2. Install the barbed fittings into the INPUT and OUTPUT connections on the rear panel of the Compressor.

CAUTION

Do not overtighten the barbed fittings. Damage to the INPUT and OUTPUT connector threads may occur.

3. Using a wrench, tighten the barbed fittings.
4. Connect the Supply flexible water line to the INPUT barbed fitting and secure with a hose clamp.
5. Connect the Return flexible water line to the OUTPUT barbed fitting and secure with a hose clamp.
6. Allow water to flow and check for leaks at the rear of the Compressor.

Electrical Connections

The following procedures provide information for making all three phase (180 - 250 VAC) electrical connections to the Compressor.

Power Cable Preparation



WARNING

Follow all local high voltage safety precautions when performing this procedure to reduce the possibility of electrical shock. Make sure all electrical power is OFF before proceeding with this procedure.

CAUTION

The cable used for making the Compressor power cable must be 10 gauge, 3 conductor cable with ground rated at 600 VAC.

1. Cut a 10 AWG (6.00 mm²), 3 conductor cable with ground to an appropriate length.
2. Strip the cable jacket back 4 in. (101.6 mm).
3. Strip the insulation back 3/8 in. (9.3 mm) on each individual conductor.
4. Install a #10 ring tongue terminal on the end of each conductor using the appropriate size double crimping tool.
5. Remove the rear panel as shown in [Figure 3-2](#).
6. Remove the circuit breaker terminal cover as shown in [Figure 3-2](#).
7. Install the cable into the Compressor through the cable strain relief.
8. Remove the 10-32 nut and install the grounding wire on the ground stud. Install the nut and tighten to 18 in.-lbs (0.21m-kg).

NOTE: Use a slotted screwdriver which is capable of holding a screw when performing steps 9 and 10.

9. Remove the screws from the Compressor circuit breaker terminals X, Y, and Z as shown in [Figure 3-2](#).

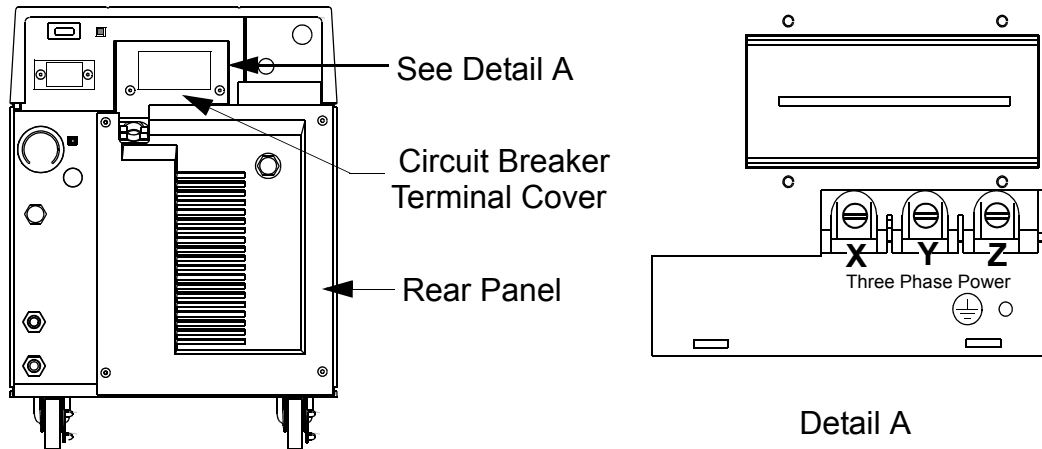

Figure 3-2: 9600 Compressor Circuit Breaker Terminals (Cover Removed)

***NOTE:** The phase order in which the conductor terminal lugs are connected to circuit breaker terminals X, Y, and Z will be determined during the Phase Check Procedure.*

***NOTE:** For installation where one of the three phase legs is at or near ground potential, connect that leg to terminal Y on the Compressor as shown in [Figure 3-2](#).*

10. Install the conductor terminal lugs to the circuit breaker terminals X, Y, and Z as shown in [Figure 3-2](#).
11. Torque the screws to 12 in.-lbs (0.14m-kg).
12. Allow enough cable to stay in the electrical enclosure to prevent strain on the electrical connections and tighten the screws on the cable strain relief.
13. Install the power source end of the power cable according to the local electrical codes.
14. Install the circuit breaker terminal cover.
15. Proceed with **Phase Check**.

Phase Check



WARNING

Follow all high voltage safety precautions when performing this procedure to prevent the possibility of electrical shock.

1. Make sure power is applied to compressor circuit as described in [Table 1-2](#).

NOTE: The circuit breaker will trip immediately during step 2 if the power phase connections are not correct.

2. Turn the Compressor circuit breaker to the ON position. If the circuit breaker trips, refer to step 3. If the circuit breaker does not trip, refer to step 4.
3. If the circuit breaker trips, perform the following steps:
 - a. Turn the Compressor circuit breaker to the OFF position.
 - b. Disconnect the power cord from the power source.
 - c. Remove the circuit breaker terminal cover.
 - d. Reverse the wiring order of Compressor circuit breaker terminals X and Y.
 - e. Torque the circuit breaker terminal screws to 12 in.-lbs.
 - f. Install the circuit breaker terminal cover.
 - g. Repeat steps 1- 2 of this procedure.
4. Install the rear panel.
5. Proceed with appropriate cryopump connections.

Connecting/Disconnecting Helium Flex Lines

CAUTION

Make sure the helium flex lines are connected and disconnected from the 9600 Compressor using the following procedure and as shown in [Figure 3-3](#). Failure to follow this procedure could damage connector O-ring seals or cause a helium circuit leak.

Connecting

1. Remove all dust plugs and caps from the Gas Supply and Return lines, and the Compressor and cryopump Supply and Return connectors. Check for the presence of a flat gasket in the male connector, and no gasket in the female connector.
2. Connect the Gas Return line to the GAS RETURN connector on the rear of the Compressor and then to the GAS RETURN connector on the cryopump. Using two wrenches as shown in [Figure 3-3](#), tighten the connector.
3. Connect the Gas Supply line to the GAS SUPPLY connector on the rear of the Compressor and then to the GAS SUPPLY connector on the cryopump. Using two wrenches as shown in [Figure 3-3](#), tighten the connector.
4. Attach the Supply and Return line identification labels to each end of the appropriate lines.

Disconnecting

1. Using two wrenches as shown in [Figure 3-3](#), disconnect the two self sealing coupling connectors quickly to minimize helium leakage.

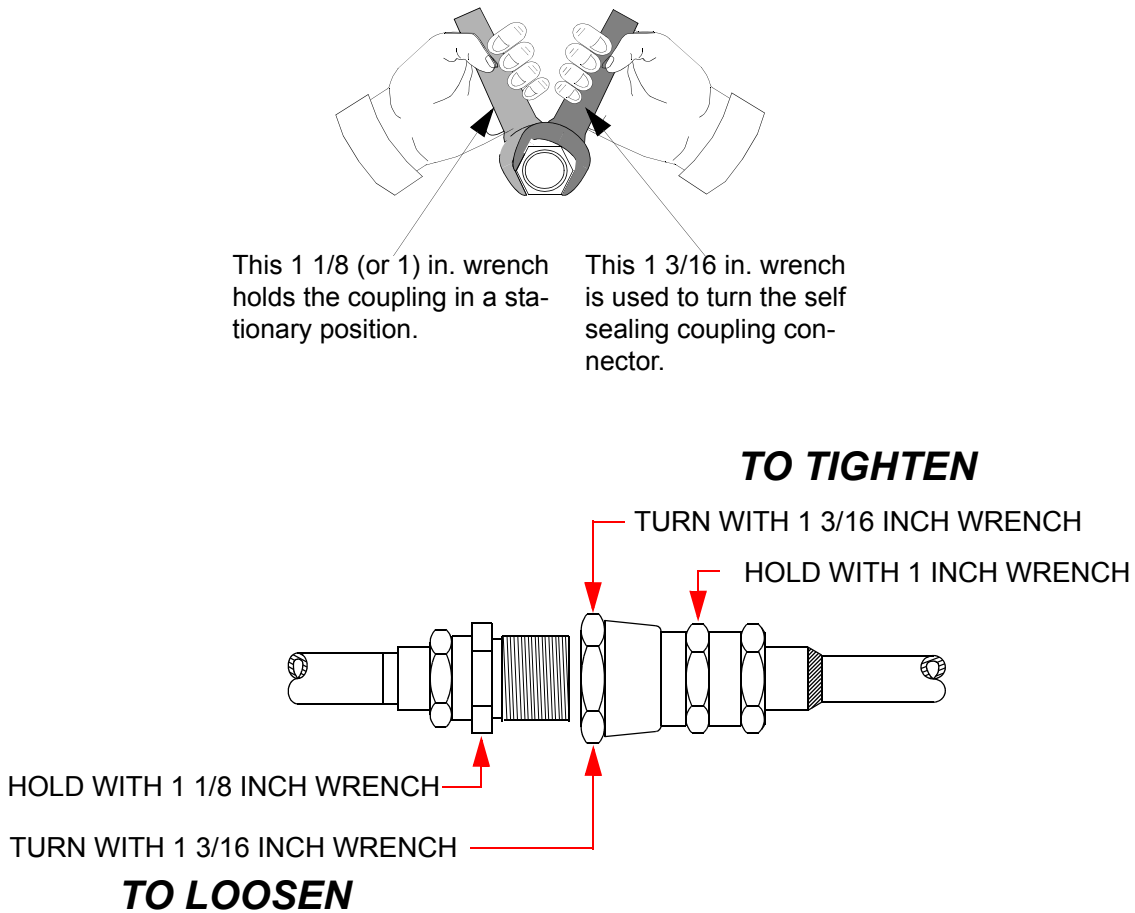

Figure 3-3: Connecting/Disconnecting Helium Flex Line Couplings

Single On-Board Cryopump Connections

CAUTION

Make sure the Compressor power is OFF before making any connections to the rear panel.

1. Connect the Supply and Return lines to the 9600 Compressor as described in [“Connecting/Disconnecting Helium Flex Lines”](#) in this section.
2. Connect one end of the Cryopump cold head cable to the CRYOPUMP ELECTRICAL OUTLET on the rear panel of the Compressor as shown in [Figure 3-4](#).
3. Connect the opposite end of the cold head cable to the cryopump

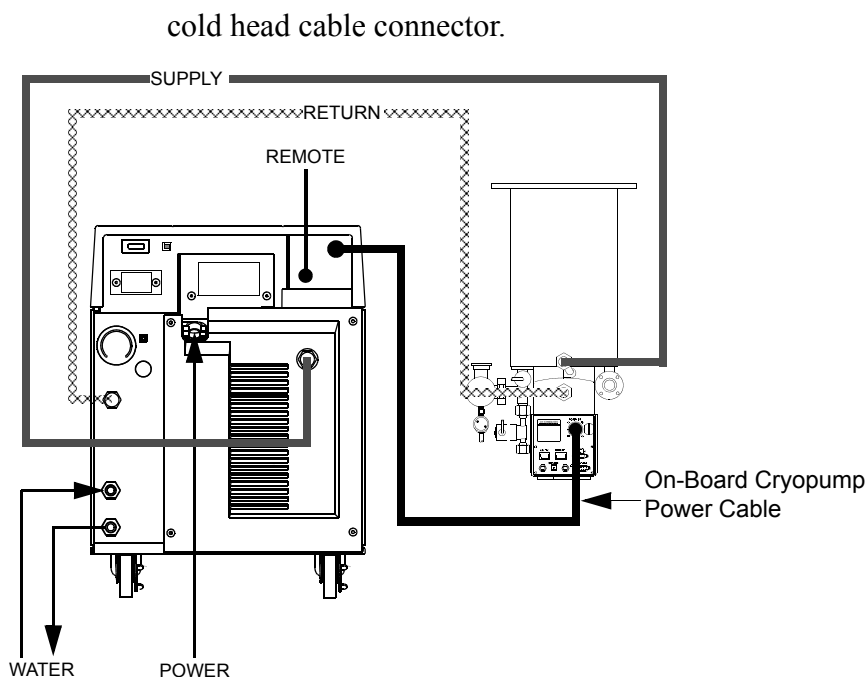

Figure 3-4: Single On-Board Cryopump Connections

CAUTION

Make sure the Compressor power is OFF before making any connections to the rear panel.

1. Connect the Supply and Return lines to the 9600 Compressor as described in [“Connecting/Disconnecting Helium Flex Lines”](#) in this section.
2. Connect one end of the Cryopump cold head cable to the CRYOPUMP ELECTRICAL OUTLET on the rear panel of the Compressor as shown in [Figure 3-5](#). Connect the opposite end of the cold head cable to the cryopump cold head cable connector as shown in [Figure 3-5](#).

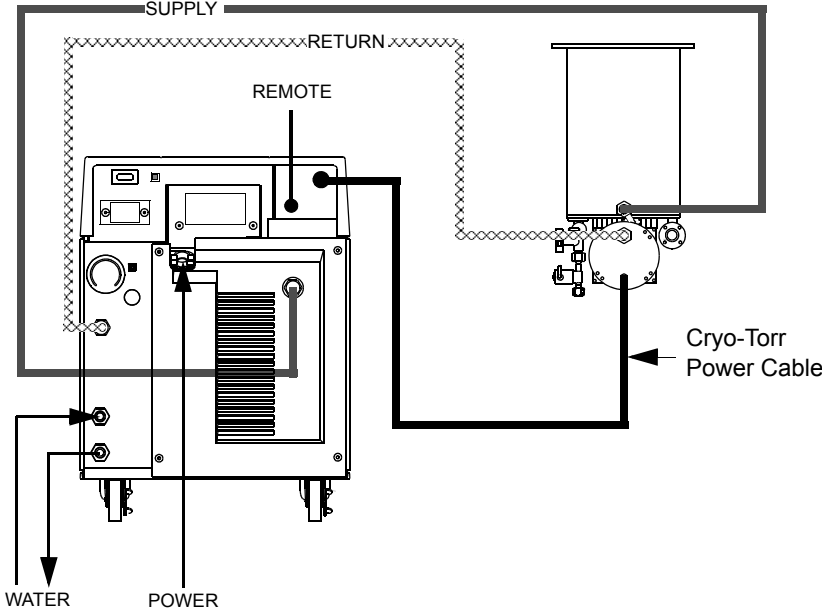

Figure 3-5: Single Cryo-Torr Cryopump Installation

Multiple On-Board Cryopump Connections

CAUTION

Make sure the Compressor power is OFF before making any connections to the rear panel.

Helium Line Connections

CAUTION

The use of several compressors on a single manifold feeding a common supply header and a common return header requires special precautions. Contact BROOKS-CRYOGENICS for a review of the intended installation and for specific technical instructions.

The use of a 9600 compressor on a manifold with other BROOKS-CRYOGENICS compressor models requires a reduction of the helium charge pressure to 200 - 210 psig charge pressure to avoid helium safety valves from inadvertently venting. Refer to [“Section 4 - Operation”](#) and [“Section 5 - Maintenance”](#) for more information.

1. Connect the Supply and Return lines to the 9600 Compressor as described in [“Connecting/Disconnecting Helium Flex Lines”](#) in this section.
2. Connect the Gas Return Line to the customer supplied helium manifold and then to the GAS RETURN connector on the On-Board Cryopump.
3. Connect the Gas Supply Line to the customer supplied helium manifold and then to the GAS SUPPLY connector on the On-Board Cryopump.

Power Cable Connections

1. Connect the On-Board Splitter Box power cable between the CRYOPUMP ELECTRICAL OUTLET on the rear panel of the Compressor and the On-Board Splitter Box power connector as shown in [Figure 3-6](#).
2. Connect the On-Board Cryopump or Waterpump power cables to the CRYOPUMP 1, 2, or 3 connectors on the On-Board Splitter Box and the respective cryopumps as shown in [Figure 3-6](#).

NOTE: Your installation (number of pumps per compressor) will vary based upon the On-Board Cryopump models used. Refer to “[Appendix A: Customer Brooks Automation Technical Support Information](#)” to consult your local BROOKS-CRYOGENICS Customer Support Center for information on specific compressor/pump applications.

NOTE: The On-Board Splitter Box can be installed at the process tool containing the pumps as shown in [Figure 3-6](#), or on the rear of the Compressor as shown in [Figure 3-7](#). BROOKS-CRYOGENICS recommends that the On-Board Splitter box be installed near the process tool to reduce cable requirements.

NOTE:

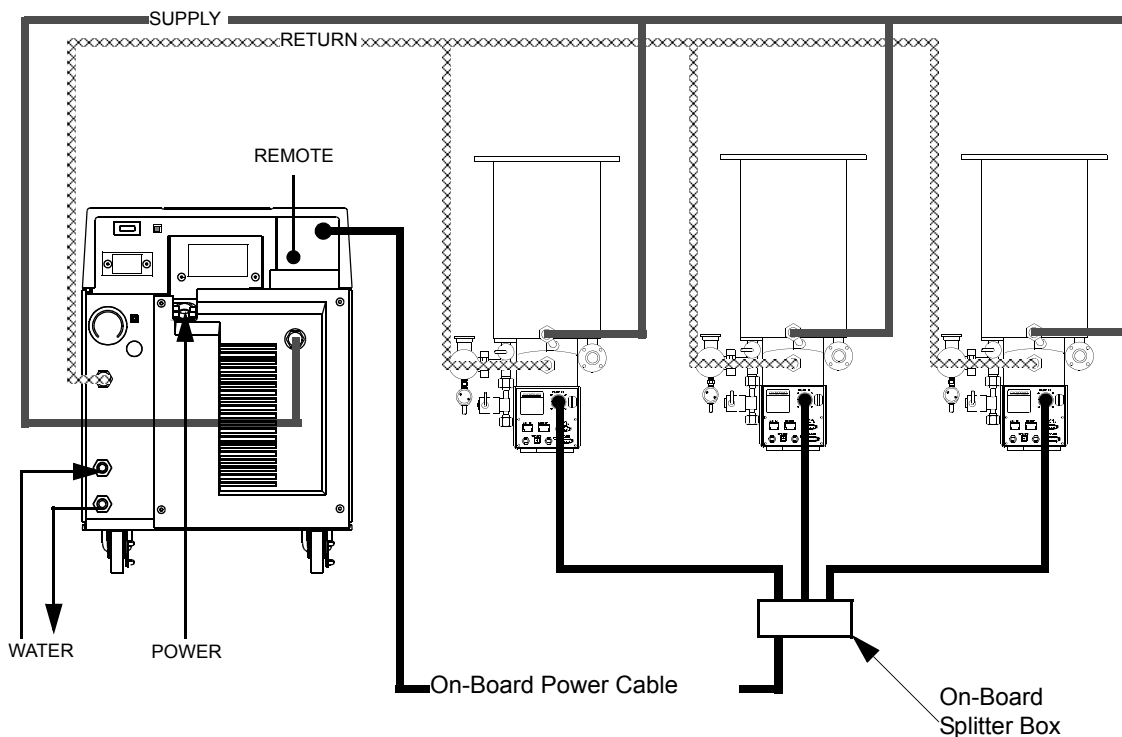
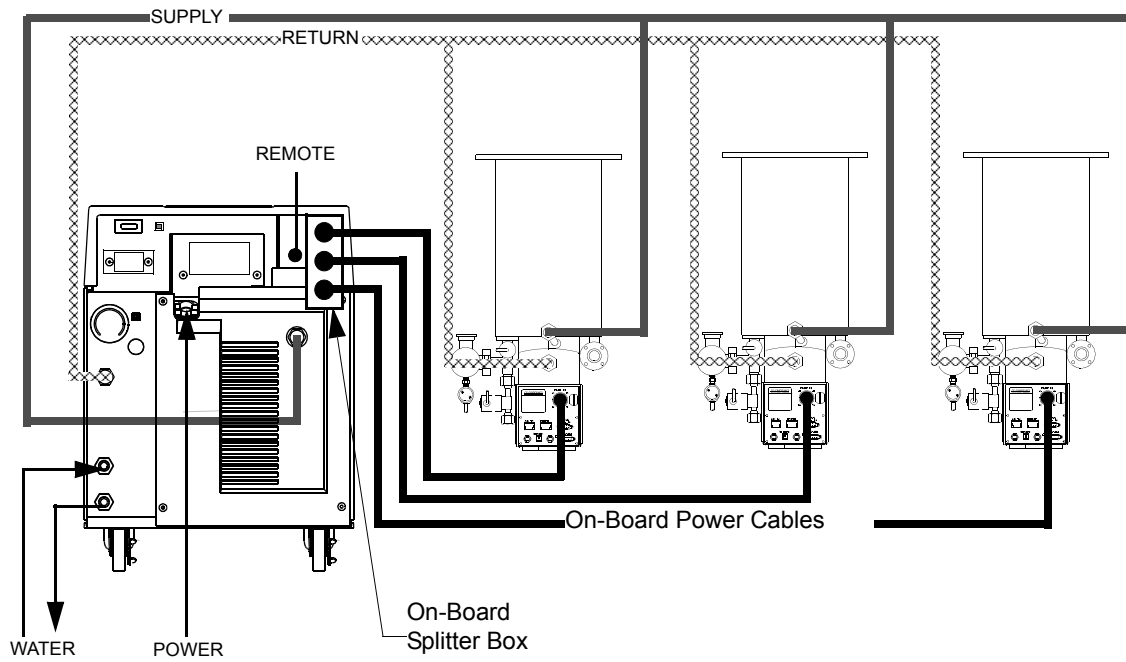

Figure 3-6: Recommended Multiple On-Board Cryopump or Waterpump Installation



(Splitter Box located at Process Tool)

**Figure 3-7: Alternative Multiple On-Board Cryopump or Waterpump Installation
(Splitter Box located at Compressor)**

Multiple Cryo-Torr Cryopump Connections

CAUTION

Make sure the Compressor power is OFF before making any connections to the rear panel.

Helium Line Connections

CAUTION

The use of several compressors on a single manifold feeding a common supply header and a common return header requires special precautions. Contact BROOKS-CRYOGENICS for a review of the intended installation and for specific technical instructions.

The use of a 9600 compressor on a manifold with other BROOKS-CRYOGENICS compressor models requires a reduction of the helium charge pressure to 200 - 210 psig charge pressure to avoid helium safety valves from inadvertently venting. Refer to [“Section 4 - Operation”](#) and [“Section 5 - Maintenance”](#) for more information.

1. Connect the Supply and Return lines to the 9600 Compressor as described in [“Connecting/Disconnecting Helium Flex Lines”](#) in this section.
2. Connect the Gas Return Line to the customer supplied helium manifold and then to the Gas Return connector on the Cryo-Torr Cryopump.
3. Connect the Gas Supply Line to the customer supplied helium manifold and then to the Gas Supply connector on the Cryo-Torr Cryopump.

Power Cable Connections

1. Connect the Cryo-Torr power cable between the CRYOPUMP ELECTRICAL OUTLET on the rear panel of the Compressor and the CRYOPUMP ELECTRICAL INPUT on the Cryo-Torr Interface as shown in [Figure 3-8](#) or [Figure 3-9](#).
2. Connect the Cryo-Torr Power Cables between the CRYOPUMP 1,

- 2, or 3 connectors on the Cryo-Torr Interface and the respective Cryo-Torr Cryopumps as shown in [Figure 3-8](#) or [Figure 3-9](#).
3. Connect the User Remote cable to the Cryo-Torr Interface as shown in [Figure 3-8](#) or [Figure 3-9](#).
4. Connect the Remote cable between the Cryo-Torr Interface and the Compressor as shown in [Figure 3-8](#) or [Figure 3-9](#).

NOTE: Your installation may vary based upon the Cryo-Torr Cryopump models used. Refer to “[Appendix A: Customer Brooks Automation Technical Support Information](#)” to consult your local BROOKS-CRYOGENICS Customer Support Center for information on specific compressor/cryopump applications.

NOTE: The Cryo-Torr Interface can be installed at the process tool containing the cryopumps as shown in [Figure 3-8](#) or near the Compressor as shown in [Figure 3-9](#). BROOKS-CRYOGENICS recommends that the Cryo-Torr Interface be installed at the process tool to reduce cable requirements.

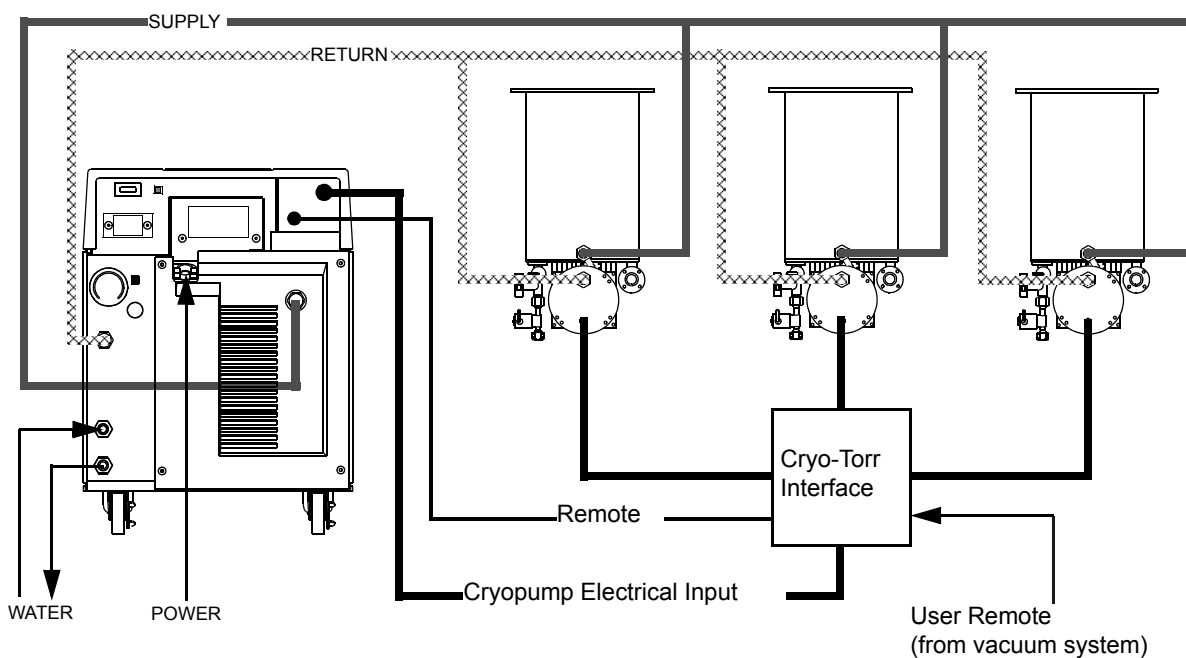

Figure 3-8: Multiple Cryo-Torr Cryopump Installation

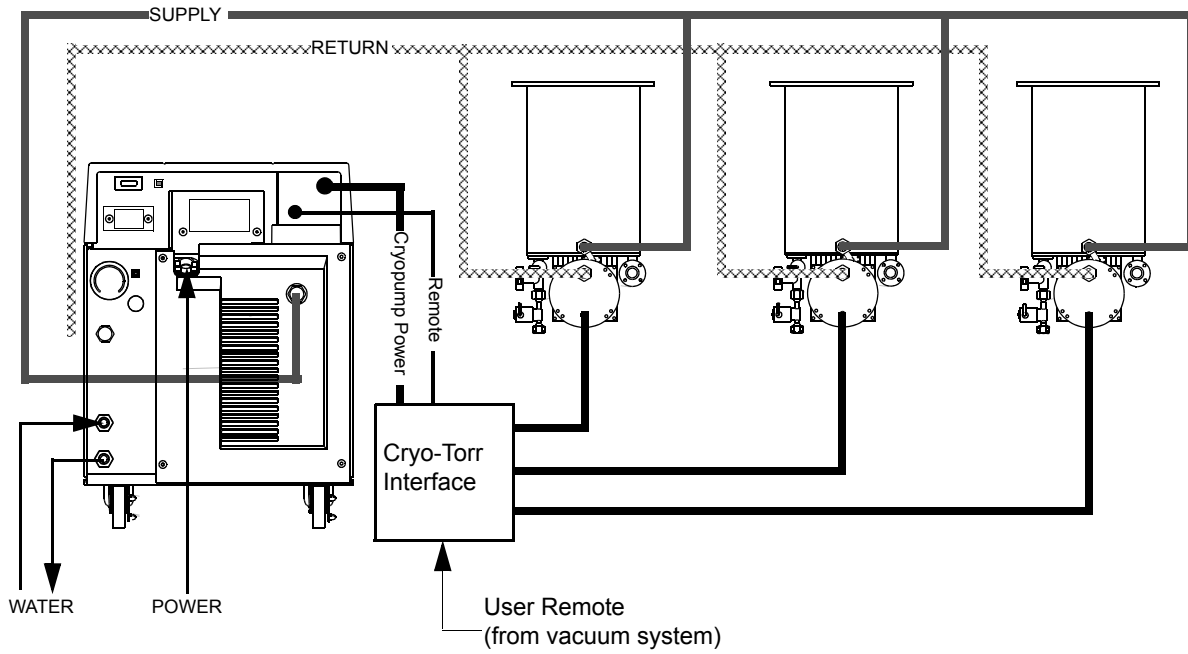

Figure 3-9: Multiple Cryo-Torr Cryopump Installation

Section 4 - Operation

Adjusting System Helium Pressure

Your BROOKS-CRYOGENICS high vacuum pump system is comprised of several pressurized components i.e. compressor, flex lines, and cryopumps. Each component is charged with helium before shipment. After all cryopumps, helium lines, and manifolds are attached to the compressor, the system (*"OFF" Condition*) helium charge pressure must be verified *before* system operation. Once the (*"OFF" Condition*) helium system pressure has been verified, the system is ready for operation. After cooldown, the *normal system operating pressure* is recorded.

NOTE: *The 9600 Compressor is designed for continuous operation and should remain ON even when the cryopumps are in a regeneration cycle.*

"OFF" Condition Helium System Pressure Verification

The proper system (*"OFF" Condition*) helium charge pressure is necessary so that the cryopumps operate at maximum performance as well as to assure that the compressor will operate below the maximum design motor winding temperature which will maximize the life of the compressor motor.

1. Make sure the Compressor and Cryopump(s) are OFF.
2. Make sure all system components are connected together as described in "[Section 3 - Installation](#)".
3. Allow all system components to acclimate to a temperature between 60° F and 80° F (15.5° C - 26.6° C).
4. Read the compressor helium pressure gauge located on the compressor rear panel as shown in [Figure 1-4](#). Compare the gauge reading to the appropriate 50/60 Hz line frequency value (depending upon your system installation) indicated in [Table 4-1](#).

Table 4-1: 9600 Compressor Helium ("OFF" Condition) Charge

Line Frequency	Helium ("OFF" Condition) Charge Pressure
60 Hz	240 - 250 psig (16.5 - 17.2 bars)
50 Hz	255 - 265 psig (17.6 -18.3 bars)

NOTE: The use of a higher helium charge pressure for 50 HZ operation is necessary in order to compensate for the slower speed at which the compressor operates at 50 HZ. The ("OFF" Condition) charge level for 60 Hz remains at 240-250 PSIG.

CAUTION

Exceeding the recommended system ("OFF" Condition) helium charge pressure will result in the compressor and cryopump safety relief valves opening and releasing excess helium gas.

5. If the ("OFF" Condition) helium charge pressure is not in the ranges as indicated in [Table 4-1](#), then adjust the charge pressure as described in "[Section 5 - Maintenance](#)".

Compressor Operation

CAUTION

While the 9600 Compressor is operating, the helium pressure gauge indicator should never be in the red zone. If the gauge indicator is below 65 psig, then the system must be checked for insufficient helium or helium leaks. If the gauge indicator is above 160 psig, then the system has been over pressurized. Refer to "[Section 5 - Maintenance](#)" and either add or remove helium before operating the 9600 Compressor.

The system may be operated once the helium charge pressure is correct. Perform the following steps to start the compressor:

1. Set the System Circuit Breaker to the ON (UP) position.
2. Set the Control Circuit Breaker to the ON (UP) position.
3. Close all Cryopump gate valves.
4. Refer to the **On-Board Module Programming and Operation** manual or **Cryo-Torr Cryopump Installation and Service** manual (that came with your cryopump) and perform the cryopump start-up procedure.
5. Once the second stage temperature for all cryopumps is below 17K, record the compressor pressure gauge reading as the *normal system operating pressure*.

NOTE: During compressor operation, the compressor gauge reads the pressure of the gas entering the compressor prior to it being compressed.

6. Affix a copy of the data next to the compressor gauge on each compressor. This data is to be verified for each tool installation and whenever a configuration change is made affecting the amount of system helium gas and line volume.

The compressor pressure reading will decrease from the normal system operating pressure during cryopump regeneration or if fewer cryopumps are being operated. These are normal variations in the compressor pressure reading and should not be cause for concern.

If you have concerns about system performance changing, then check the *normal system operating pressure* which was determined in “[Compressor Operation](#)” in this section. If the normal system operating pressure is not correct, check the system for leaks.

Once the leaks have been repaired, helium must be added to return the system to *normal operating system pressure* as described in “[Section 5 - Maintenance](#)”.

Replacement of Helium Circuit Components

On occasion, it may be necessary to replace components such as cryopumps, helium gas lines or compressors, or change the configuration of the system. Whenever any of these conditions occur, **"OFF" Condition Helium System Pressure Verification** should be performed to ensure that ("OFF" Condition) helium pressure has not changed.

CAUTION

The use of several compressors on a single manifold feeding a common supply header and a common return header requires special precautions. Contact BROOKS-CRYOGENICS for a review of the intended installation and for specific technical instructions. The use of a 9600 compressor on a manifold with other BROOKS-CRYOGENICS compressor models requires a reduction of the helium charge pressure to 200--210 psig charge pressure to avoid helium safety valves from inadvertently venting.

This Page Intentionally Left Blank

Section 5 - Maintenance

Scheduled Maintenance

Suggested Maintenance Equipment

It is recommended to have the following equipment and disposable supplies available as listed in [Table 5-1](#).

Table 5-1: Suggested Maintenance Equipment

Supply	BROOKS-CRYOGENICS P/N
Helium, 99.999% pure	-
Pressure regulator (0-3000/0-400 psi) Assy.	8031403
Helium charging line terminating in a 1/4-inch female flare fitting	7021002P001
Lint-free gloves and cloth	-
Oakite or equivalent detergent soap	-
Denatured alcohol	-
Refer to “Appendix A: Customer Brooks Automation Technical Support Information” and contact the local Customer Support Center to obtain the BROOKS-CRYOGENICS parts listed in this table.	

Adsorber Replacement

Use the following procedure to change the adsorber every three years.

1. Set the System Circuit Breaker, on the rear of the 9600 Compressor, to the OFF position.
2. Remove the 4 screws which secure the rear panel to the Compressor and remove the rear panel.

NOTE: Use two wrenches in Step 3 to prevent loosening the body of the coupling.

3. Using a 1-3/16 in. wrench, and a 1-1/8 in. wrench, as shown in [Figure 5-1](#), disconnect the two self sealing coupling connectors quickly to minimize helium leakage.

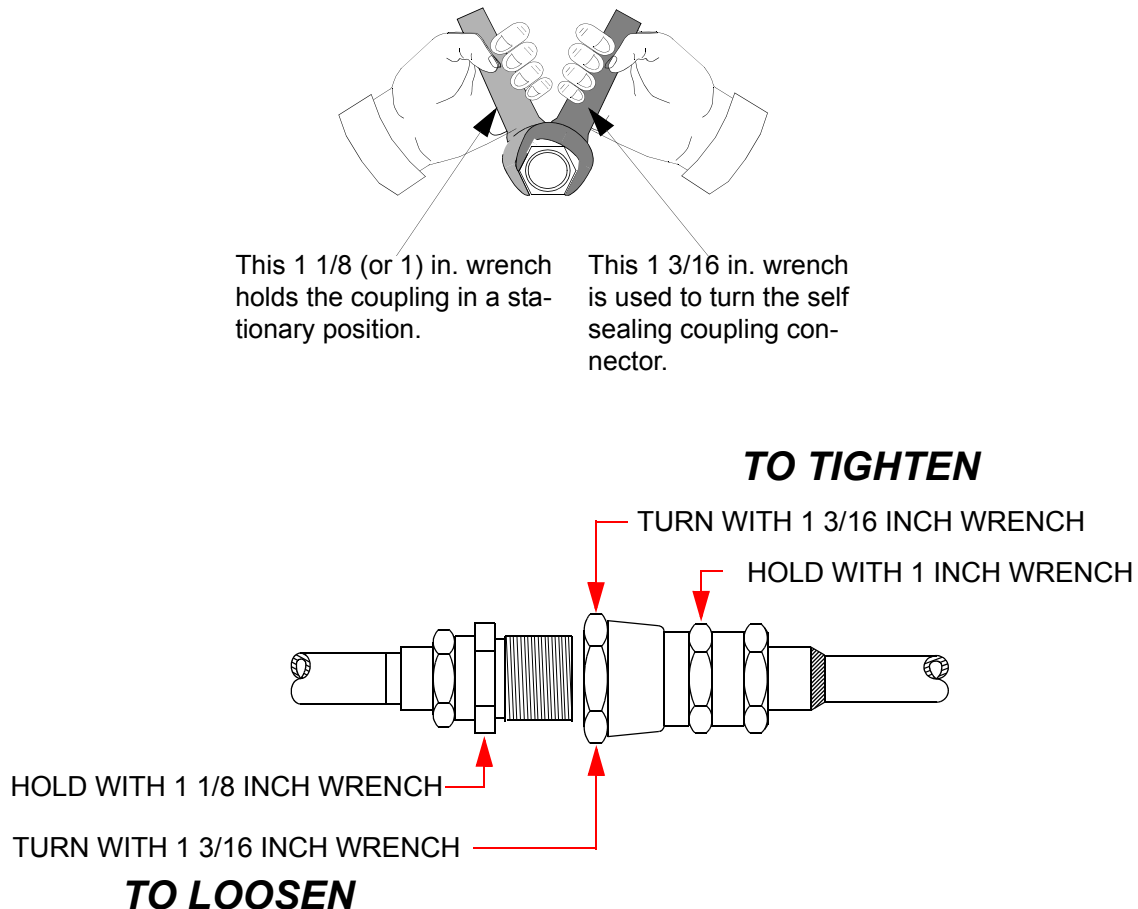

Figure 5-1: Disconnecting Self Sealing Couplings

4. Using a 7/16 in. (11mm) wrench, remove the adsorber mounting bolt as shown in [Figure 5-2](#).

5. Move the adsorber from under the mounting tabs in the base as shown in [Figure 5-2](#) and remove the adsorber from the Compressor.
6. Install the replacement adsorber under the mounting tabs and secure it into place with the bolt removed during Step 4.
7. Using two wrenches as shown in [Figure 5-1](#), connect the two self sealing couplings quickly to minimize helium leakage.
8. Install the Compressor rear panel.
9. Ensure that the pressure gauge reads the proper value as shown in [Table 4-1](#). If additional gas pressure is required, refer to “[Adding Helium](#)” in this section. If gas pressure needs to be reduced, refer to “[Reducing Helium Pressure](#)” in this section.
10. Record the adsorber replacement date on the label as shown in [Figure 5-2](#), and also note that the next adsorber replacement should be performed every three years.

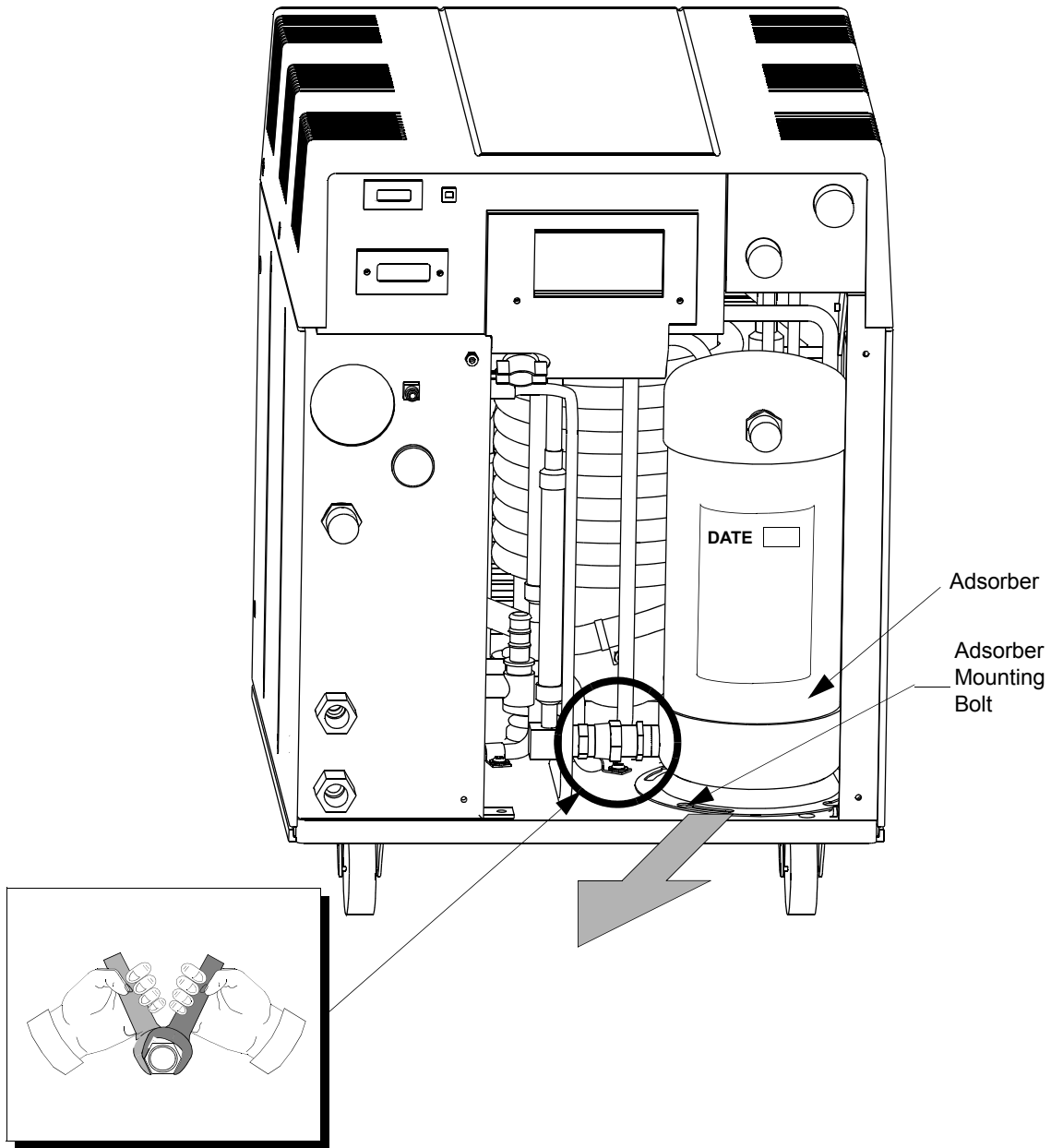

Figure 5-2: Adsorber Location in 9600 Compressor (Rear Panel Removed)

Adjusting System Helium Pressure

NOTE: These procedures can be performed on a compressor that is turned ON or OFF. However, the helium pressure gauge should be set to the ("OFF" Condition) helium charge pressure value if the compressor is turned OFF or set to the normal system operating pressure if the compressor is turned ON. Refer to "Section 4 - Operation" for more information.

Reducing Helium Pressure

NOTE: You must obtain the normal system operating pressure from the "Compressor Operation" procedure in "Section 4 - Operation" in order to perform this procedure. If the normal system operating pressure is unknown, then shut the compressor OFF and perform the "OFF" Condition Helium System Pressure Verification" procedure in "Section 4 - Operation" instead.

1. Remove the flare cap from the gas charge fitting as shown in Figure 5-3.

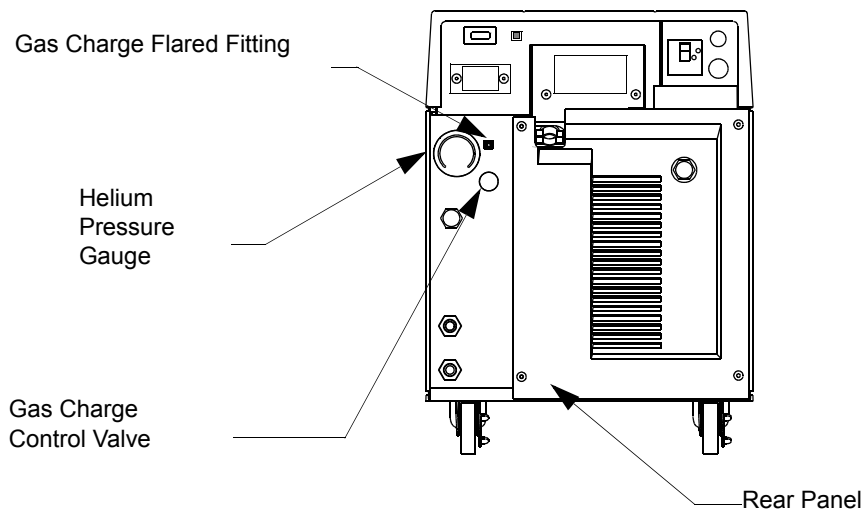

Figure 5-3: Helium Pressure Control Components

2. Open the gas charge control valve *very slowly* to allow a slight amount of helium to escape. Leave the valve open until the helium pressure gauge indicates one of the following:
 - To the appropriate value in Table 4-1 if the compressor is OFF and acclimated to a temperature between 60° F and 80° F

(15.5° C - 26.6° C).

- To the value previously recorded in the “Compressor Operation” procedure in “Section 4 - Operation” if the compressor is ON.
3. Close the gas charge control valve and install the flare cap.

Increasing Helium Pressure

Use the following procedure to increase the helium pressure if the indicated pressure is below the appropriate value as shown in [Table 4-1](#).

CAUTION

If helium is being added more than once every several months, check for leaks caused by improperly connected self-sealing connections or any mechanical joint in the Compressor.

Adding Helium

NOTE: You must obtain the normal system operating pressure from the “Compressor Operation” procedure in “Section 4 - Operation” in order to perform this procedure. If the normal system operating pressure is unknown, then shut the compressor OFF and perform the “OFF Condition Helium System Pressure Verification” procedure in “Section 4 - Operation” instead.

This procedure ensures that both the regulator and the charging line will be purged of air and that the air trapped in the regulator will not diffuse back into the helium bottle. For best results, BROOKS-CRYOGENICS suggests a dedicated helium bottle, regulator, and line, which are never separated, for adding helium.

NOTE: You are required to supply the helium charging line terminating in a 1/4-inch female flare fitting, and a two-stage pressure regulator rated at 0-3000/0-400 psig for this operation.

CAUTION

Use only 99.999% pure helium gas. Helium circuit contamination may result if a lower quality of helium is used.

1. Attach a regulator (0-3000/0-400 psig) and charging line to a helium bottle (99.999% pure).

NOTE: *Do not open the bottle at this time.*

2. Purge the regulator and charging lines as follows:
 - a. Open the regulator a small amount by turning the adjusting knob clockwise until it contacts the diaphragm, then turn approximately 1/8 to 1/4 turn more, so that the regulator is barely open.
 - b. Loosely connect the charge line to the helium pressure regulator.
 - c. Slowly open the bottle valve, and purge the regulator and line for 10 to 15 seconds. Turn the regulator knob counterclockwise until the helium stops flowing.
3. Remove the flare cap of the gas charge flared fitting on the rear of the Compressor.
4. Loosely connect the charging line from the helium pressure regulator to the 1/4-inch male flare fitting installed on the helium charge valve. Purge the charge line again, as in step a, for 30 seconds, and tighten the charge line flare fitting onto the gas charge fitting while the helium is flowing.
5. Set the helium pressure regulator to 300 psig (20.7 bars). If the compressor is ON, proceed with step a. If the compressor is OFF, proceed with step b.
 - a. Obtain the previously recorded *normal system operating pressure* from the “Compressor Operation” procedure in “Section 4 - Operation”. Open the gas charge control valve *very slowly* and allow helium to flow until the compressor gauge reading is the same as the value obtained from “Section 4 - Operation”. Quickly close the gas charge control valve.
 - b. Obtain the appropriate (50 or 60 Hz) (“OFF” Condition) *system operating pressure* from Table 4-1. Open the gas charge control valve *very slowly* and allow helium to flow until the compressor gauge reading is the same as the appropriate value in Table 4-1. Quickly close the gas charge control valve.
6. Ensure that the helium charge valve on the Compressor is tightly closed. Shut off the helium pressure regulator on the helium bottle and remove the charging line from the male flare fitting. Reinstall the flare cap.

This Page Intentionally Left Blank

Appendix A: Customer Brooks Automation Technical Support Information

When contacting Brooks Automation for Technical Support, please have the following information available.

1. Record the part number and serial number from the equipment.
2. Provide the installed location of the equipment.
3. Provide name, e-mail address, and telephone number of the person to contact.
4. List any error codes received during the failure.
5. Prepare a detailed description of the events relating to the error.
 - Time that the equipment has been in operation
 - Work that was done on the equipment prior to the error
 - Functions that the equipment was performing when the error occurred
 - Actions taken after the error and the results of those actions
 - Other information that may assist the Specialist
6. Contact Brooks Automation Technical Support at these numbers:

Brooks Location	GUTS [®] Contact Number
North America	1-800-FOR-GUTS (1-800-367-4887) US/Canada +1-978-262-2900
Europe	+49 1804 CALL GUTS (+49 1804 2255 4887)
Japan	+81-45-477-5980
China	+86-21-5131-7066
Taiwan	+886-3-552-5225
Korea	+82-31-288-2500
Singapore	+65-6464-1481

For additional contact information, please go to the Brooks Automation web site at www.brooks.com or send an E-mail to techsupport@brooks.com.

This Page Intentionally Left Blank

Appendix B - Flow Diagram

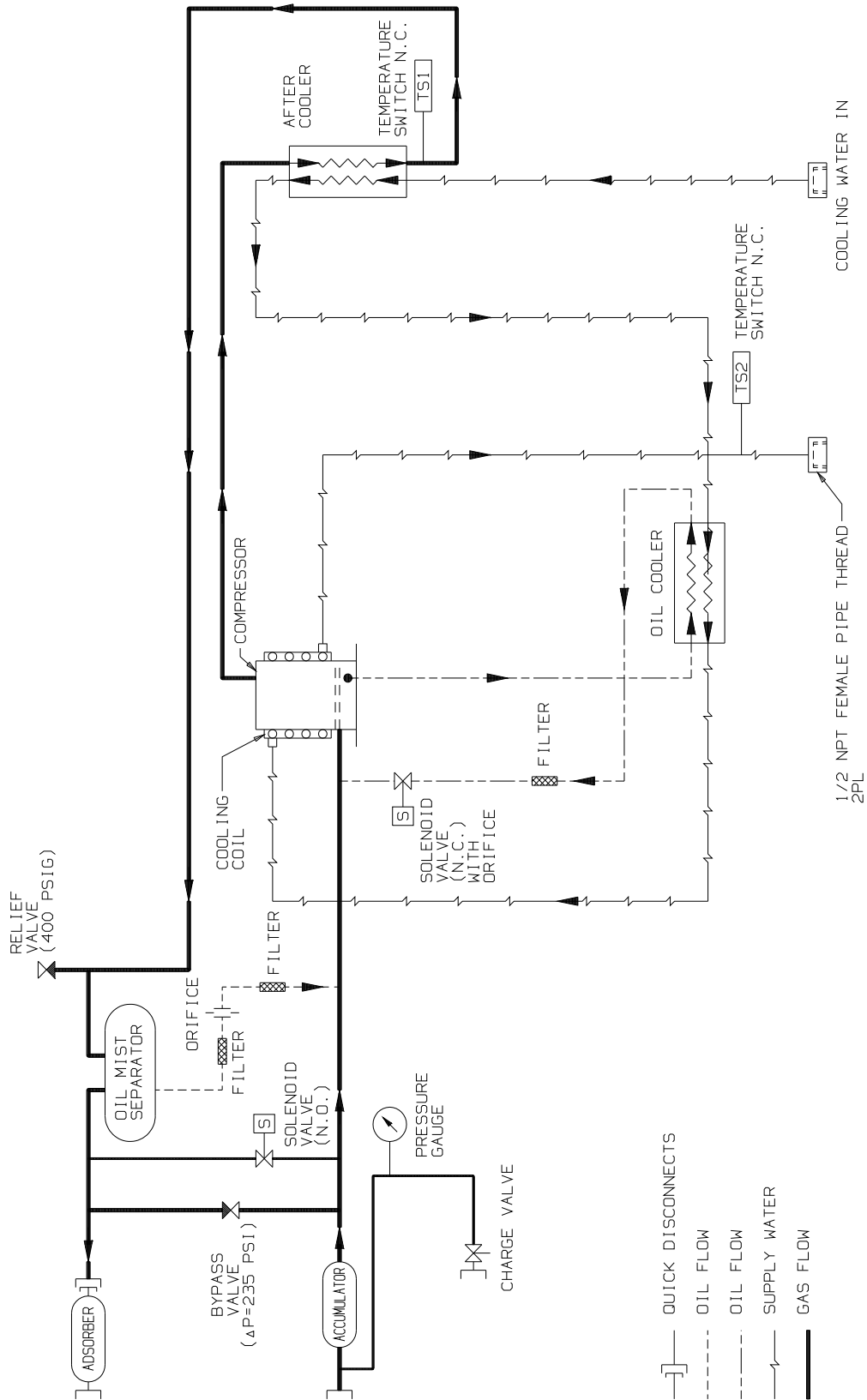

Figure B-1: 9600 Compressor Flow Diagram P/N 8135001 Rev. A

Appendix C - Troubleshooting Procedures

Troubleshooting the Compressor

The compressor troubleshooting procedures are summarized in [Table C-1](#).

Technical Inquiries

Please refer to “[Appendix A: Customer Brooks Automation Technical Support Information](#)” of this manual for a complete list of the

BROOKS-CRYOGENICS’ world wide customer support centers.



CAUTION

Disconnect the compressor before performing any troubleshooting procedures. The compressor pump is hot after operating. Wait for the pump to cool down before working on the inside of the compressor

Do not change or modify any compressor internal wiring circuits, this may cause failure of the compressor and cold head due to improper phasing.

Table C-1: Compressor Troubleshooting Procedures

Problem	Possible Cause	Corrective Action
1) System circuit breaker (CB1) trips immediately to the OFF (0) position when switched to the ON (1) position.	1) Incorrect phasing of input power.	1) Check phasing of input power. Refer to “ Phase Check ” in “ Section 3 - Installation ”.
2) System (CB1) and Control Circuit (CB2) circuit breakers remain in the ON (1) position when switched ON but the compressor will not run.	1) No power coming from source. 2) Insufficient power 3) Remote control jumper plug not in place. This will apply only if remote circuit <i>is not</i> being used. 4) Improperly wired external remote control circuit. NOTE: Only applies if remote control feature is being used.	1) Check source fuses, circuit breakers, and wiring associated with the power source. Repair as needed. 2) Verify adequate phase-to-phase input voltage. Refer to Table 1-2 . 3) Check to insure that remote jumper plug is fully seated. See Figure 1-4 for location. Refer to “ Compressor Remote Connector ” in “ Section 1 - 9600 Compressor Description ” for more information. 4) Verify correct installation of remote control feature. Refer to Table 1-6 .

Table C-1: Compressor Troubleshooting Procedures (Continued)

Problem	Possible Cause	Corrective Action
<p>3) System circuit breaker (CB1) will not remain in the ON (1) position when switched ON. The Control Circuit circuit breaker (CB2) trips when excessive current is being drawn by the cold head or 24 volt compressor control circuits.</p>	<p>1) Damaged On-Board power cable, connectors, or drive motor.</p> <p>2) Damaged component in the compressor power or control circuit.</p>	<p>1) Check for compressor operation with cryopump cable disconnected from compressor. Refer to “Appendix A: Customer Brooks Automation Technical Support Information” to contact the Customer Support Center if the compressor operates improperly.</p> <p>2) Refer to “Appendix A: Customer Brooks Automation Technical Support Information” to contact the Customer Support Center.</p>
<p>4) System circuit breaker (CB1) remains in the ON (1) position and the compressor stops after several minutes of operation and remains OFF (0).</p>	<p>1) Thermal protective switches are open.</p> <p>2) Very cold water has caused a restriction of oil flow through the oil injection orifice during start-up.</p>	<p>1) Check for inadequate water cooling. Refer to Table 1-3.</p> <p>2) Recheck for proper cooling water temperature. Refer to Table 1-3. Restart compressor repeatedly until continuous operation is achieved.</p>
<p>5) System circuit breaker (CB1) trips after a period of running.</p>	<p>1) Loss or degradation of power from the source.</p> <p>2) Defective motor windings.</p>	<p>1) Check that line voltage is correct on all phases.</p> <p>2) Check running current on all phases.</p> <p>3) Refer to “Appendix A: Customer Brooks Automation Technical Support Information” to contact the local Customer Support Center.</p>

This Page Intentionally Left Blank

Appendix D - Schematic

Introduction

The schematic in Appendix D supports the 9600 (High Voltage) Compressor BROOKS-CRYOGENICS P/N 8135164P002.

Table D-1: Basic Control Assembly Legend

Identifier	Description
1M	Compressor Motor
CB1	Main Circuit Breaker (15A)
CB2	Control Circuits Circuit Breaker (4A)
ETM	Elapsed Time Meter
ETM1	Elapsed Time Meter
J15	Module Power Receptacle
J1/P1	Autoset Power Connector
J2/P2	Unload Solenoid Connector
J3/P3	Oil Solenoid Connector
J4/P4	Helium Thermal Switch
J5/P5	Water Thermal Switch
J6/P6	Compressor Contactor Coil
J7/P7	Autoset Input Connector
J8	ETM Connector
M1	Contactor 7.5 HP IEC
J9/P9	LT1 Connector
J10/P10	Control Transformer
J11	Open
J12	Module Signal Connector
J13/P13	Phase Monitor
J14	Open

Table D-1: Basic Control Assembly Legend (Continued)

Identifier	Description
K2	Over Temperature Lockout Relay
LT1	Lamp, 24-28V LED Green
M1OL	Relay, Overload (10-16A - set at 10A)
PM1	Phase Monitor OMRON RDR-TFY-M
PWB1	PWB Autoset
T3	Transformer Assembly Control

Table D-2: On-Board/Cryo Electrical Module P/N 8135127G002 Legend

Identifier	Description
JT1	Open
JT2	Open
JT3/PT3	T2 Cold Head Supply, 2 phase
JT4/PT4	T1 Cold Head Supply, 2 phase
JT5/PT5	T2 Cold Head Transformer Output
JT6/PT6	T1 Cold Head Transformer Output
JT7/PT7	T4 Supply
JT8/PT8	T4 Low Voltage Output (23/26 VCT)
J18	Power Output
J19	Signal Output
P12	Signal Input Connector
P15	Power Input Connector
K1	Cold Head Voltage Relay
K2	Signal Voltage Relay
K3	Cryo Power Relay
T1-T2	Cold Head Motor Transformers
T4	On-Board Logic Power Transformer
T5	On-Board Heater Power Transformer

Table D-3: On-Board Output Module P/N 8135148G001 Legend

Identifier	Description
J30	On-Board Output Receptacle
J31	Remote Control Receptacle
P18	Power Connector
P19	Signal Connector
P31	Remote Jumper

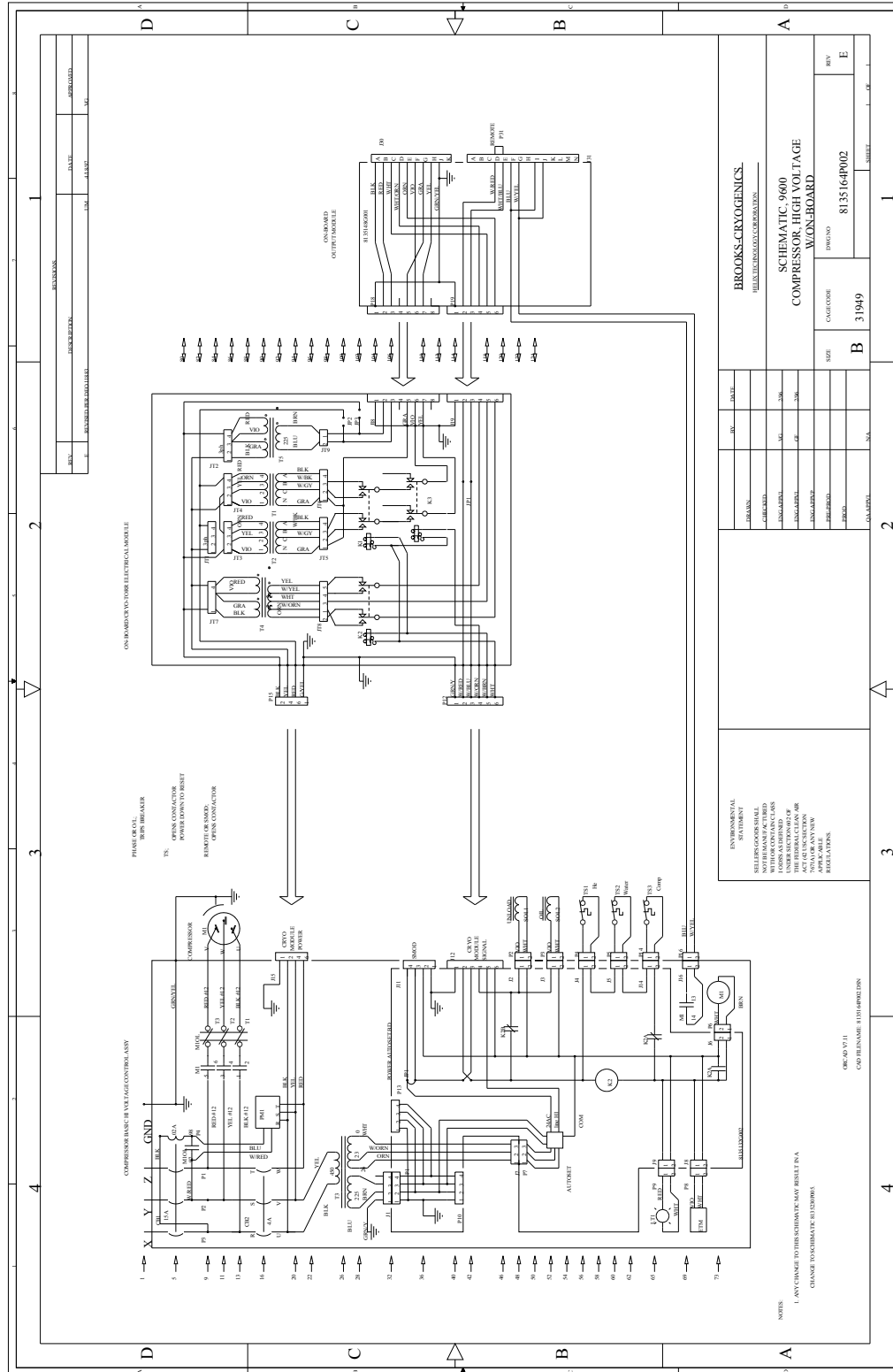

Figure D-1: 9600 High Voltage Compressor

Index

A

Adsorber
replacing, 5-2

B

Brooks Automation
contact information, Front-ii

C

Components
compressor remote connector, 1-11
control circuit breaker, 1-9
cooling water IN, 1-10
cooling water OUT, 1-10
Cryopump electrical outlet, 1-10
description, 1-8
elapsed time meter, 1-9
gas charge flared fitting, 1-9
helium pressure gauge, 1-10
power inlet, 1-10
power ON indicator, 1-9
return gas coupling, 1-10
supply gas coupling, 1-11
system circuit breaker, 1-9

Compressor
description, 1-1
installing, 3-1
operation, 4-2
schematic, D-4

Compressor remote connector, 1-11

Control circuit breaker, 1-9

Cooling water IN, 1-10

Cooling water OUT, 1-10

Cryopump electrical outlet, 1-10

E

Elapsed time meter, 1-9

Electrical
connecting, 3-4

F

Flow diagram, B-1

G

Gas charged
flared fitting, 1-9

H

Helium
adding, 5-6
refrigeration system, 1-1
Helium circuit components
replacing, 4-3
Helium flex lines
connecting/disconnecting, 3-7
Helium pressure
increasing, 5-6
reducing, 5-5
system, adjusting, 4-1
Helium pressure gauge, 1-10
Helium pressure, system
adjusting, 5-5

M

Maintenance, 5-1–5-7
Multiple Cryo-Torr connections, 1-13
Multiple Cryo-Torr pumps
connecting, 3-14
Multiple On-Board Cryopump
connections, 1-12
Multiple On-Board Cryopumps
connecting, 3-11

O

OFF condition helium system pressure
verifying, 4-1

P

Phase checks

performing, 3-6
Power inlet, 1-10
Power ON indicator, 1-9

R

Return gas coupling, 1-10

S

Safety precautions, S-1
Schematic, D-1, D-4
 basic control assembly legend, D-1
 On-Board output module legend, D-3
 On-Board/Cryo electrical module legend, D-2
Single On-Board Cryopumps
 connecting, 3-8
Specifications, 1-4
Supply and return water lines
 connecting, 3-3
Supply gas coupling, 1-11
System circuit breaker, 1-9

T

Troubleshooting, C-1–C-3

U

Unpacking, 2-1–2-2