

4 Installation Procedure

General Information	40
Preparation for Installation	41
Installation	43
Use	44
Operating Procedure	45
Maintenance	47
Disposal	47

Original Instructions



Agilent Technologies

General Information

This equipment is destined for use by professionals. The user should read this instruction manual and any other additional information supplied by Agilent before operating the equipment. Agilent will not be held responsible for any events occurring due to non-compliance, even partial, with these instructions, improper use by untrained persons, non-authorized interference with the equipment or any action contrary to that provided for by specific national standards.

The VacIon Plus series pumps are ion pumps commonly used to create ultra-high vacuum, due to their cleanliness, ability to pump different gases, and maintenance- and vibration-free operation.

The following paragraphs contain all the information necessary to guarantee the safety of the operator when using the equipment. Detailed information is supplied in the appendix "Technical Information".

This manual uses the following standard protocol:

WARNING!



The warning messages are for attracting the attention of the operator to a particular procedure or practice which, if not followed correctly, could lead to serious injury.

CAUTION!

The caution messages are displayed before procedures which, if not followed, could cause damage to the equipment.

NOTE

The notes contain important information taken from the text.

Preparation for Installation

The pump is supplied in a special protective packing. If this shows signs of damage which may have occurred during transport, contact your local sales office. When unpacking the pump, be sure not to drop it and avoid any kind of sudden impact or shock vibration to it. Do not dispose of the packing materials in an unauthorized manner. The material is 100 % recyclable and complies with EEC Directive 85/399.

CAUTION!

In order to prevent outgassing problems, do not use bare hands to handle components which will be exposed to vacuum. Always use gloves or other appropriate protection.

NOTE

Normal exposure to the environment cannot damage the pump. Nevertheless, it is advisable to keep it closed until it is installed in the system, thus preventing any form of pollution by dust.

4 Installation procedure

Preparation for Installation

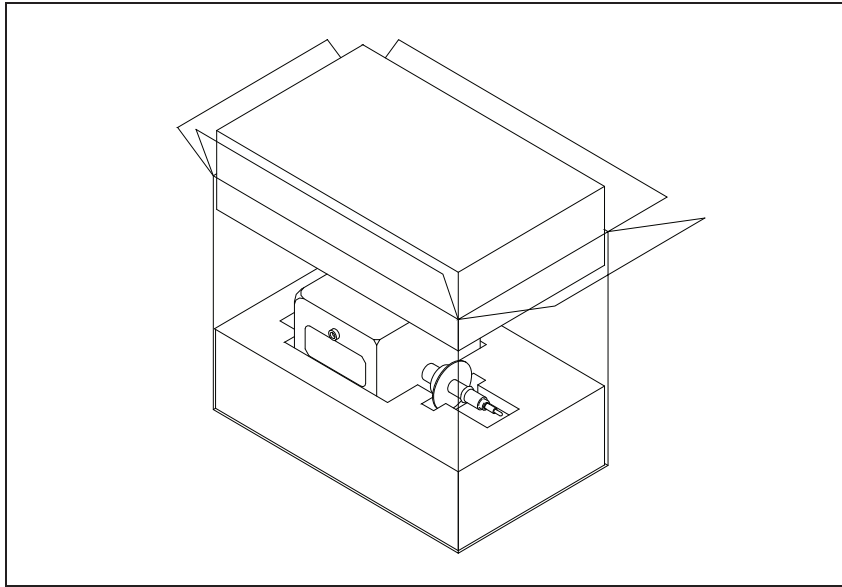

Figure 1

Installation

Do not install or use the pump in an environment exposed to atmospheric agents (rain, snow, ice), dust, aggressive gases, or in explosive environments or those with a high fire risk. During operation, to obtain the specified operation, the ambient temperature must be between 0 °C and +85 °C.

CAUTION!

The pump should be kept sealed with its pinch-off tubulation until it is ready for attachment to the vacuum system.

WARNING!

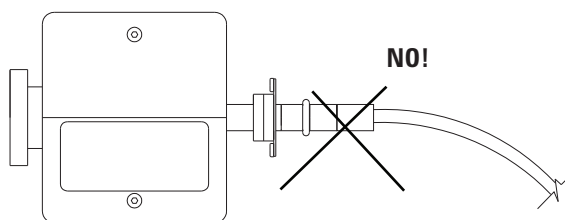

To avoid injury, never connect the high voltage to the pump before it is installed into the system and all the inlet flanges are properly connected or blanked off.

The pump operation is optimized using one of the special Agilent controllers (Dual, MidiVac or MiniVac) only.

4 Installation procedure

Use

CAUTION!

The safety specifications agreement using the pump is guaranteed using the Agilent controller only.

The VacIon Plus pump can be installed in any position. For convenience, a pump is usually mounted vertically with the inlet up. Pumps can be supported by the mounting flange in any position. For detailed information about the pump installation, see the appendix “Technical Information”.

Use

All the instructions for the correct use of the VacIon Plus pumps are contained in the control unit manual. Read the manual carefully before using the pump. Rough pumping down to 1×10^{-4} Torr (mbar) is recommended for the most rapid starting. Roughing with an oil-sealed mechanical pump is not desirable, but when used, a trap in the roughing line is recommended to reduce pressure due to water vapor and oils from the mechanical pump. Be careful to minimize the time that this pump is open to the system and ion pump, since mechanical pump vapors will start diffusing into the system at pressures below 1×10^{-1} Torr (mbar) and cause contamination. In systems where oils must be completely eliminated, turbopump roughing pumps should be used. Hygroscopic deposits and hydrogen absorption into titanium may cause starting times to increase with age. During exposure to air, the deposits of titanium compound absorb water vapor. In subsequent start ups, pump heating causes release of the water vapor and some previously pumped hydrogen; thus, the starting time may be lengthened.

Operating Procedure

Check that the controller HV polarity is correct for the pump: positive polarity for Diode pumps and negative for StarCell or Triode pumps. Refer to the relevant pump control unit instruction manual and follow the procedure below when operating the pump:

- 1 With a clean roughing pump, establish a minimum starting pressure in the vacuum system per the table on page 9 for the type of ion pump.
- 2 Plug the control unit into a suitable power source and switch the power ON.
- 3 Observe the voltage, current, and roughing pressure. If started at 5×10^{-2} Torr (mbar), a controller voltage of approximately 300 to 400 volts is typical. A current value near the short-circuit current of the control unit could indicate that an unconfined flow discharge exists in the pump and system. A temporary rise in roughing pressure will usually be noticed during any starting procedure.
- 4 Allow the roughing valve to remain open after turning on the ion pump until an adequate starting pressure is reached. If the ion pump voltage drops after closing the roughing valves, reopen the valve for additional rough pumping. As the pressure decreases, the voltage again will rise, and the roughing valve may be closed.
- 5 When the voltage has increased to 2-3 kV, place the control unit in the PROTECT condition. The system is now automatically protected against pressure increases to 10^{-4} Torr (mbar) when the pump is left unattended. If such an increase should occur, the control unit will be turned off automatically.
- 6 The pressure in the pump can also be determined by reading the current and converting this reading to pressure with the appropriate pressure versus current graph shown in the appendix "Technical Information" of this manual.

4 Installation procedure

Operating Procedure

NOTE

The steps on the pressure – current charts are a characteristic of the Dual step voltage operation. When the current drawn by the Vaclon pump reaches the specified values, the controller will change the high voltage output to a lower applied voltage.

- 7 When venting the pump, use dry nitrogen. This will avoid water vapor absorption on the pump walls.
-

WARNING!



When employing the pump for pumping toxic, flammable, or radioactive gases, please follow the required procedures for each gas disposal. Do not use the pump in presence of explosive gases.

WARNING!



When the heating element is installed, do not touch the pump during the heating and cooling phases. The high temperature may cause a serious damage.

CAUTION!

Do not put any electronic device near the pump otherwise the magnetic field around it may cause a device malfunctioning.

Maintenance

The VacIon Plus series pump does not require any maintenance. Any work performed on the pump must be carried out by authorized personnel.

WARNING!



Before carrying out any work on the pump, disconnect it from the High Voltage supply.

If a pump is to be scrapped, it must be disposed of in accordance with the specific national standards.

Disposal

Meaning of the "WEEE" logo found in labels.

The following symbol is applied in accordance with the EC WEEE (Waste Electrical and Electronic Equipment)

Directive. This symbol (**valid only in countries of the European Community**) indicates that the product it applies to must NOT be disposed of together with ordinary domestic or industrial waste but must be sent to a differentiated waste collection system.

The end user is therefore invited to contact the supplier of the device, whether the Parent Company or a retailer, to initiate the collection and disposal process after checking the contractual terms and conditions of sale.

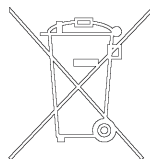

4 Installation procedure

Disposal



5 Technical Information

Description of the Vaclon Pump	51
Technical Specification	53
Vaclon Plus 20 Starcell	55
Vaclon Plus 20 Noble Diode	57
Vaclon Plus 20 Diode	59
Outline Drawing	60
Stray Magnetic Field	61
Vaclon Plus Pump Installation	63
Inspection Procedure	63
Visual Inspection	63
Vacuum Evaluation	64
Short Circuits	65
Typical Installation	66
Inlet Flange Connection	68
Control Unit Connection	71
Safety Interlock	72
Heater Installation	72
Heater Replacement	74

Original Instructions



5 Technical Information

Disposal

Bakeout Operation	74
Bakeout of Vaclon Pump with the Integral Heaters	75
Operating Procedure	76
Maintenance	77
Exchange of the High Voltage Feedthrough	78
Leakage Current Check	79
High-potting	80
Pump Troubleshooting	81
Vaclon Plus Pump Replacement Parts and Accessories	82
Vaclon Plus Pump Controllers	83

Description of the VacIon Pump

The Agilent VacIon Plus 20 pumps are ion pumps and are available in three types:

- StarCell
- Noble Diode
- Diode

They operate in the pressure range from 10^{-2} to below 10^{-11} mbar. Virtually all gases and vapors can be pumped successfully with the ion pump. The pumping speed will vary depending on the system pressure, the gas type, and the applied operating voltage. The latter can be optimized using Agilent controllers to achieve the lowest possible operating pressure.

The VacIon Plus StarCell pump allows starting from as high as 5×10^{-2} mbar, because ions are prevented from bombarding the system and pump walls at starting pressures, and have high speed for inert gases. The VacIon Plus Diode and Noble Diode pumps require a lower starting pressure (i.e. 10^{-4} mbar).

The tantalum in the Noble Diode pump enhances the noble gas pumping capacity, although it somewhat reduces the high getterable gas pumping speed that the standard diode pump provides.

The VacIon Plus StarCell is the latest variation of the Triode configuration. Its patented design makes this ion pump the only one that can handle a high amount of Noble Gases (better than Noble Diode and Triode) and Hydrogen (comparable to the Diode).

A positive polarity, high voltage supply is required to operate Diode and Noble Diode pumps. A negative polarity high voltage supply is required to operate StarCell pumps since the anode is grounded and the cathode is held at negative potential.

The inlet ConFlat flange is a 8" (NW 150).

5 Technical Information

Description of the Vaclon Pump

Fig. 2 shows the Vaclon Plus 20 pump, Fig. 3 shows the main assemblies of the pump.

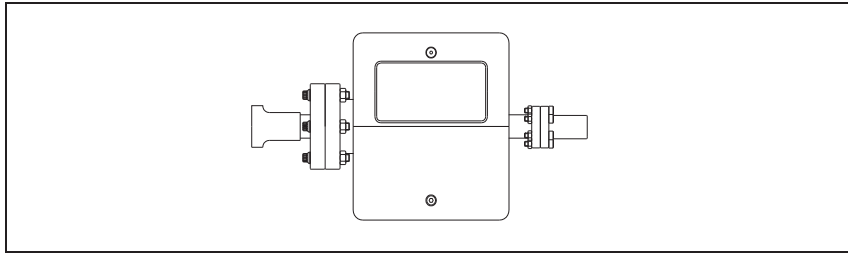

Figure 2 Vaclon Plus 20 pump

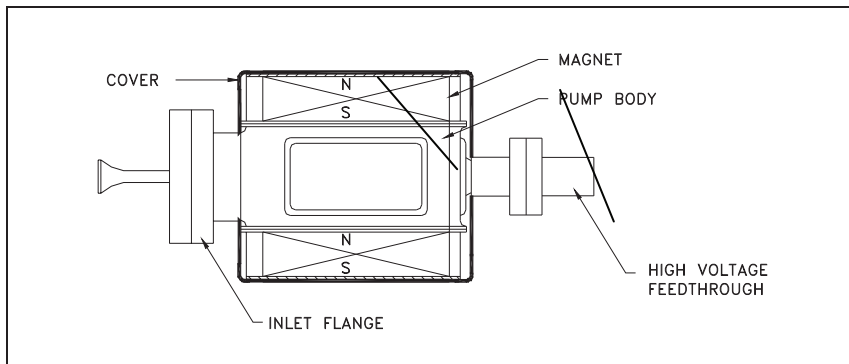

Figure 3 Pump main assemblies

Technical Specification

The following table details the main technical specifications of the VacIon Plus 20 pumps.

Tab. 1

Specification	Model		
	StarCell	Noble Diode	Diode
Nominal pumping speed for Nitrogen (*) (l/s)	20	22	27
Operating life at 1x10 ⁻⁶ mbar (hours)	80,000	50,000	50,000
Operating voltage (max)	-7000 Vdc +/- 10 %		+7000 Vdc +/- 10 %
Max starting current		150 mA	
Max baking current		10 mA	
Protect current		20 mA	
Maximum starting pressure (mbar)	≤5x10 ⁻²		≤1x10 ⁻³
Ultimate pressure		Below 10 ⁻¹¹ mbar	
Inlet flange	2 3/4" CFF (NW 35) AISI 304 ESR SST		
Internal volume (litres)		0.9	
Maximum baking temperature (°C)		350	
Temperature limits (°C):			
Pump		400	
Magnet (ferrite)		350	
Flange		500	
Material: Body		AISI 304 SST	
Cathode	Titanium	Titanium/ Tantalum	Titanium
Anode		AISI 304 SST	
Magnet		Ferrite or Sm-Co	
Weight, lbs (kg)			
with ferrite magnet		7 (11)	
with Sm-Co magnet		5 (8)	

(*) Tested according to ISO/DIS 3556-1-1992

5 Technical Information

Technical Specification

Figures 4 to 11 show the pumping speed vs. pressure diagrams for saturated and unsaturated pumps and the pressure vs. current diagrams for the same pump. The diagrams are for pumps controlled by means of a Dual controller.

The pumping speed of a newly regenerated (i.e. baked) sputter ion pump decreases during operation until it reaches a stabilized level known as "saturation" (nominal pumping speed). To saturate the VacIon Plus 20 pumps, it normally requires an amount of gas equal to 0,6 mbar-liters. Consequently, pumps can operate for extended periods of time at low pressures in the non-saturated state, if they are properly conditioned.

Vaclon Plus 20 Starcell

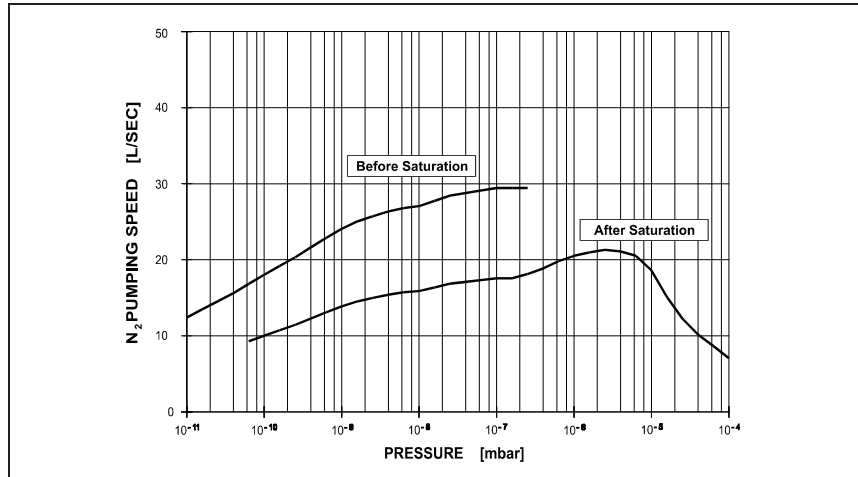

Figure 4 Pumping speed vs pressure for Nitrogen

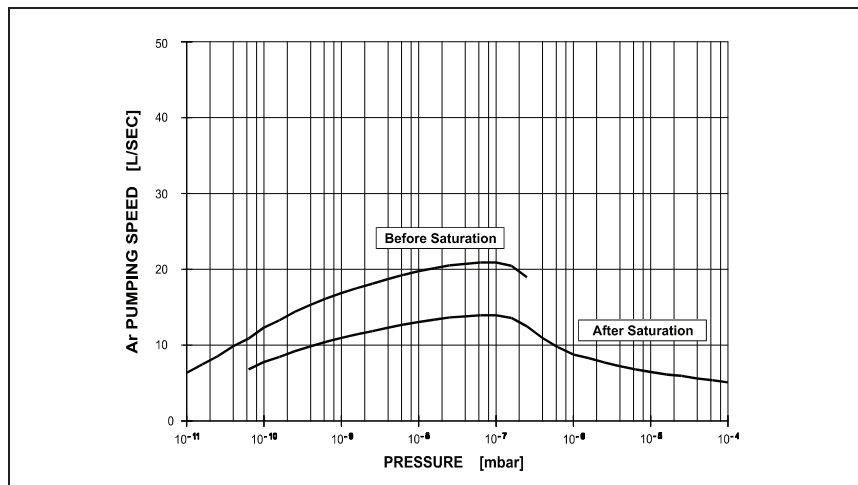

Figure 5 Pumping speed vs pressure for Argon

5 Technical Information
Vaclon Plus 20 Starcell

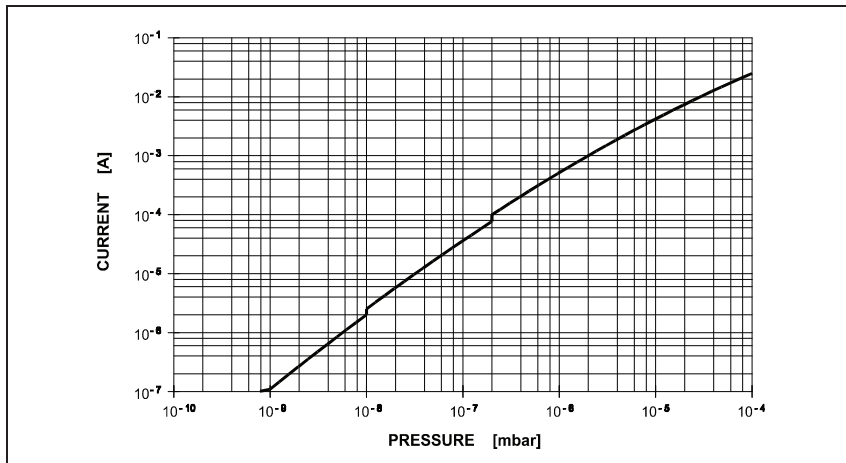

Figure 6 Pressure vs current diagram

Vaclon Plus 20 Noble Diode

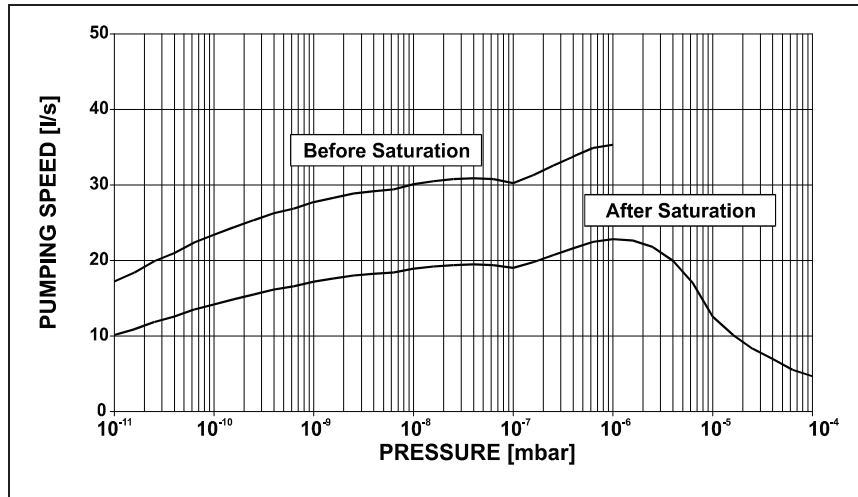

Figure 7 Pumping speed vs pressure for Nitrogen

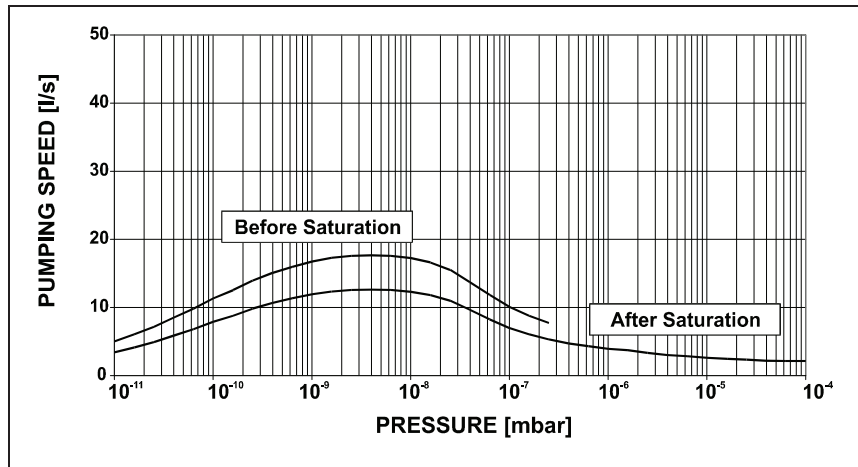

Figure 8 Pumping speed vs pressure for Argon

5 Technical Information
Vaclon Plus 20 Noble Diode

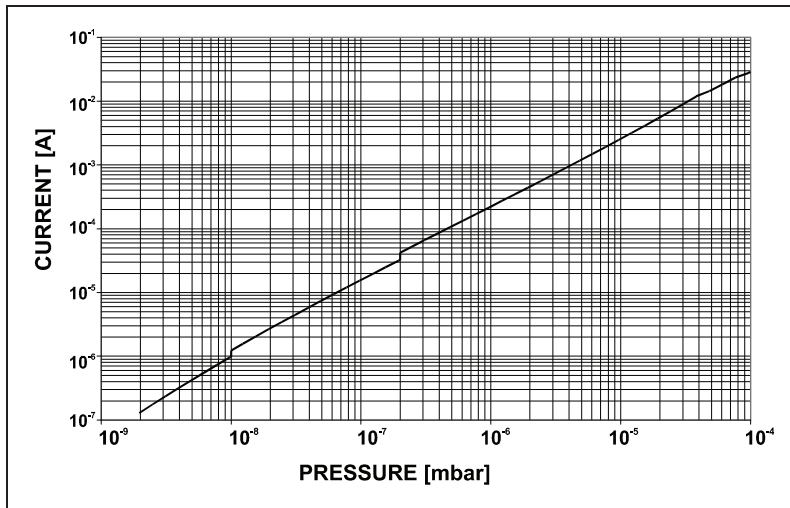

Figure 9 Pressure vs current diagram

Vaclon Plus 20 Diode

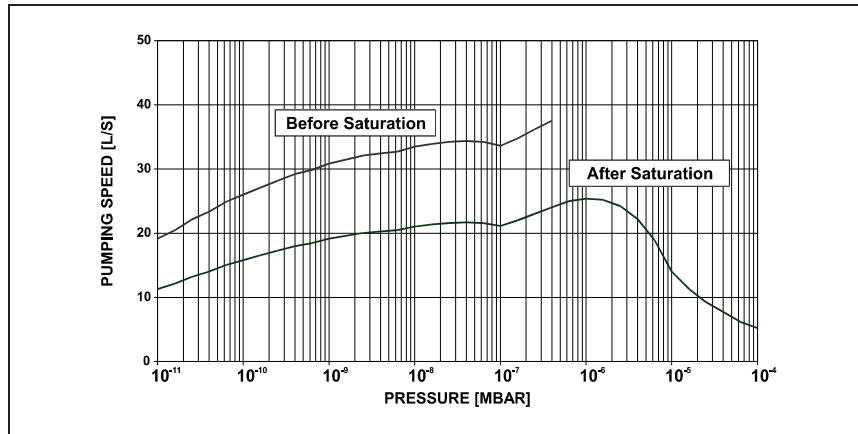

Figure 10 Pumping speed vs pressure for Nitrogen

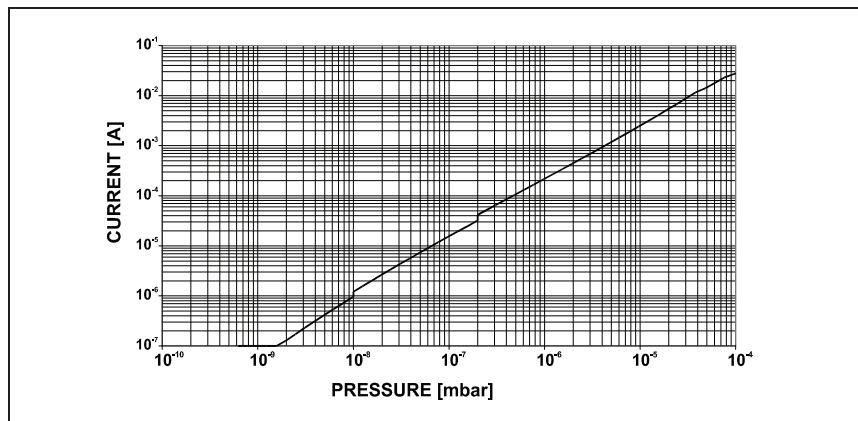

Figure 11 Pressure vs current diagram

Outline Drawing

The following figure shows the outline drawing for the Vaclon Plus pump.

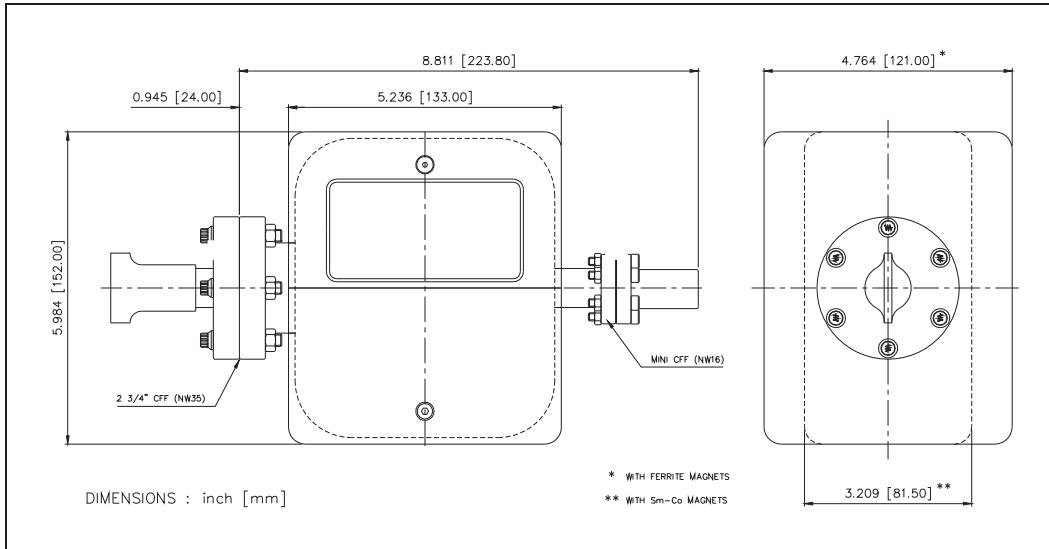

Figure 12 Vaclon Plus pump outline drawing

Stray Magnetic Field

Curves of stray magnetic field strength along the centre line of the pump and in the plane of the flange as a function of distance from the pump are shown in Figs. 14, 15 and 16.

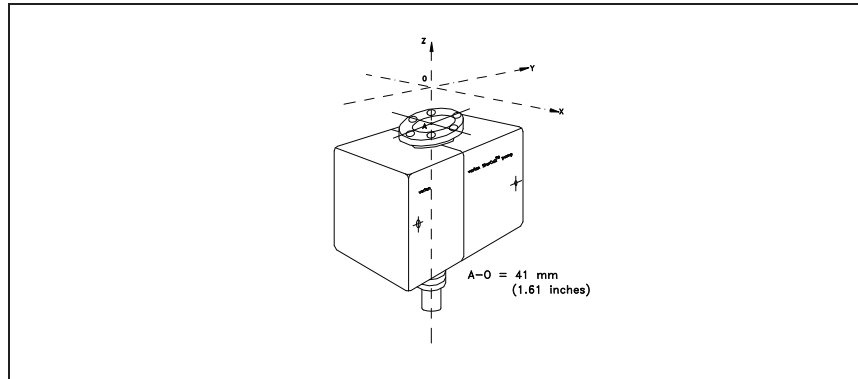

Figure 13 Vaclon Plus pump axis identification

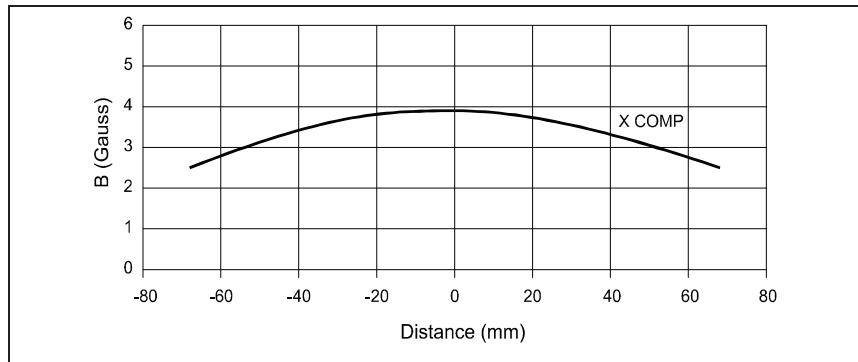

Figure 14 Stray magnetic field along X axis

5 Technical Information

Stray Magnetic Field

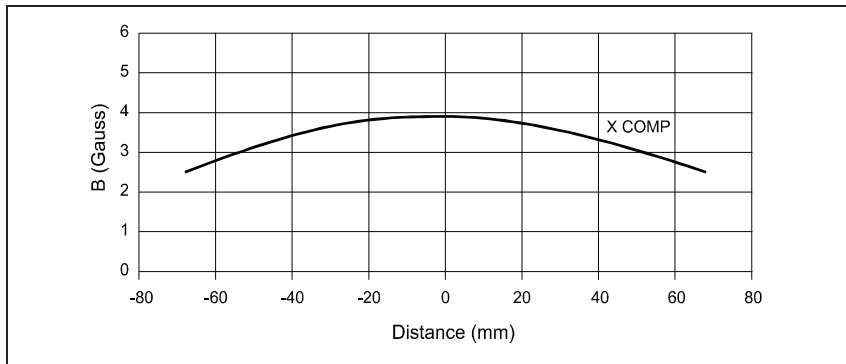

Figure 15 Stray magnetic field along Y axis

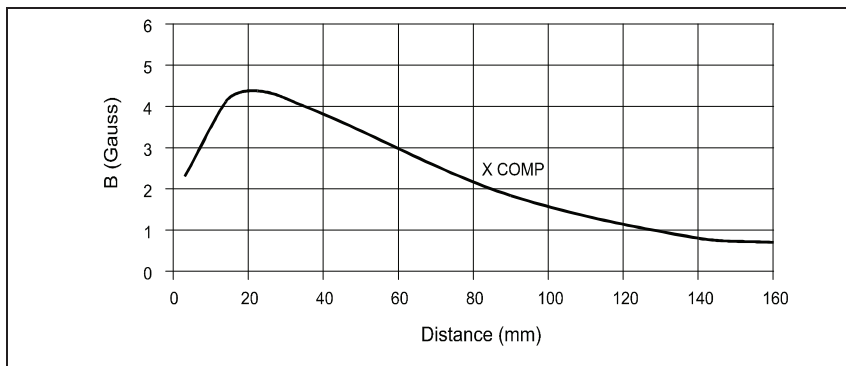

Figure 16 Stray magnetic field along Z axis

VacIon Plus Pump Installation

Inspection Procedure

VacIon Plus pumps are evacuated, baked out, sealed and leak-checked at below 1×10^{-10} mbar prior shipping. The following information and procedures can be used to optimize the vacuum integrity of a VacIon Plus pump before installation.

Visual Inspection

Inspect the pump and magnet for physical damage which may have occurred during shipment. Inspect the pinch-off seal. If it is open, the pump is at atmospheric pressure.

WARNING!

The pinch-off seal is extremely sharp. Be careful.



A VacIon Plus pump that has been exposed to atmosphere during shipment, or while in storage, will operate properly if it has not been damaged.

The pump is not harmed by such exposure, although it is good practice to keep it under vacuum when not in use to exclude dust and the accumulation of water vapor from the environment.

Vacuum Evaluation

The ion pump is shipped in an evacuated condition. Before removing the shipping flange for installation on a vacuum system, it is recommended that the pump be started briefly to verify vacuum integrity and proper operation.

To verify the vacuum integrity of the new pump before venting:

- 1 Connect the pump to the control unit as directed in the instruction manual of the control unit.

WARNING!



The high voltage which is present in the ion pump from the control unit can cause severe injury or death.

Be sure that the high voltage cable is proper connected to the ion pump and its power unit. Make sure that the pump is well grounded.

-
- 2 With the main power switch in the OFF position, plug the control unit into a suitable power source.
 - 3 Turn the power to ON.
 - 4 Observe the reading for an indication of one of the following conditions:
 - a If the pump is free of leaks and is at a low pressure, the pressure indication shall within 10 minutes fall to or below the 10^{-8} mbar range as the volume of gas is pumped.
 - b If the pressure inside the pump is at or near atmospheric level, an arc may strike inside the high voltage feedthrough giving a popping sound and the pump current will fluctuate. If this occurs, turn the power OFF immediately.
 - 5 If the vacuum integrity has been lost, the pump should be leak-checked with a mass spectrometer leak detector before installation on the system.

Short Circuits

If there is a short circuit between the anode and cathodes in the pump (or cathode to pump body), the short-circuit current of the control unit will be drawn and low voltage will be indicated. If a short circuit exists in the control unit or high voltage cable and connector, low voltage will also be observed when the high voltage connector is disconnected from the pump (refer to the control unit manuals). An ohm meter reading on the pump feedthrough may not be effective in finding a short. Short circuits may be caused by mechanical shock to the pump. If the pump is shorted, contact Agilent.

Typical Installation

A typical installation is shown in figure 17 and consists of:

1. VacIon Plus pump.
2. A Valve to seal off the pump from the rest of the system (if required).
3. The control unit.
4. A clean roughing pump (i.e. turbo or sorption).
5. A thermocouple gauge capable of indicating pressure from atmosphere to 10^{-3} mbar range.
6. A valve to seal off the roughing pump from the vacuum chamber. Roughing lines are usually made of stainless steel or copper tubing, or other low vapor pressure material.
7. High voltage cable.
8. Backing pump (diaphragm or scroll).

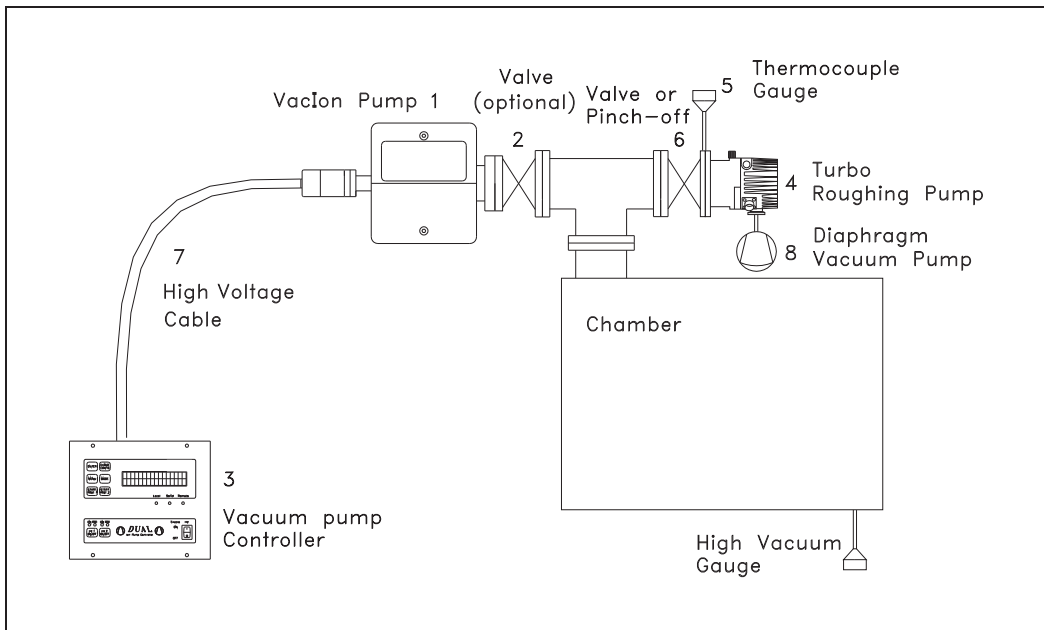

Figure 17 Typical installation

Inlet Flange Connection

The pump should be mounted allowing a sufficient clearance for installation and removal of the high voltage connector.

The pump should be kept sealed with its pinch-off tubulation until it is ready for attachment to the vacuum system. This avoids accumulation of dust and other undesirable materials. Before breaking the pinch-off seal, consult the inspection procedure (see preceding paragraph).

Vent the ion pump by opening the pinch-off tubulation in a clean area free from smog, dust, pollen, etc. Venting with dry nitrogen gas is further recommended. This can be done by placing a clean polyethylene bag over the ion pump flange. Small pumps can be placed inside of the bag. Purge the bag with clean, dry nitrogen for several minutes, then reach into the bag and release the internal vacuum using pliers to open the copper tube pinch-off.

CAUTION!

Do not open the pinch off-seal with a saw or grinder. These methods will cause metal particles to be drawn into the pump by the inrushing air as the pump is opened.

WARNING!



The pinch-off seal is extremely sharp. Be careful when opening. Watch your fingers.

Use appropriate procedures to maintain the clean condition of the pump and vacuum system.

Unscrew the main flange bolts and lift the blank flange with the help of a bolt screwed into the available threaded hole. Remove the ConFlat flange and the copper gasket plate. Some particles of copper oxide may adhere to the outer edge of the flange gasket. Be careful not to allow them or any other foreign materials to fall into the pump.

Connect the ion pump to the vacuum chamber with a short length and large diameter tubulation in order to retain as much pumping speed as possible. Proceed as follows:

- 1** Inspect the mating flanges for cleanliness and absence of scratches on the knife edge.
- 2** Place a new copper gasket between pump flange and vacuum chamber flange.
- 3** Bolt mating flanges of the pump to the chamber with the screws provided with the ion pump. For flanges over NW 35 (2.75" o.d.) also mount washers below the nuts and screw heads.
- 4** Use silver-plated screws or apply high temperature lubricant to the screw threads. Lubrication simplifies sealing and disassembly. A recommended lubricant is Fel-Pro C-100.

NOTE

Lubrication is essential to prevent galling of the nut and screw after bakeout.

- 5** Attach the nuts and tighten each one to 6 – 11 Nm (4.5 - 8 ft.-lbs) of torque. After tightening a nut, always tighten the opposite nut with respect to the center of the flange. This will partially close the gap between the flange faces.
- 6** Repeat the sequential tightening for two more cycles.
- 7** Continue tightening the bolts until the flange faces meet and a pronounced increase in torque is felt.

Note that it's not possible to install the screws from the lower side, but only from the upper side of the flange. To allow complete flexibility in the installation, a stud mounting kit is available (see Fig. 18). For ordering information refer to the "VacIon Plus Pump Replacement Parts and Accessories" paragraph.

5 Technical Information
Inlet Flange Connection

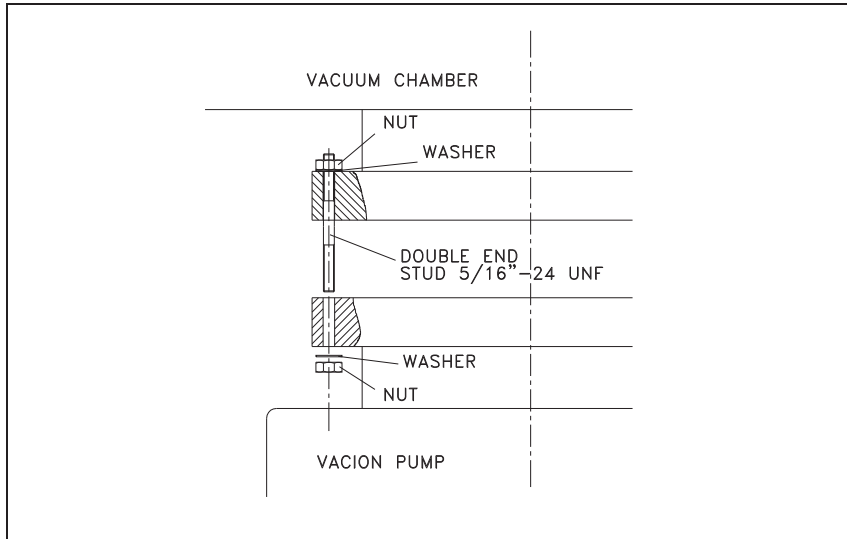

Figure 18 Stud mounting kit

Control Unit Connection

WARNING!



The high voltage present in the high voltage cable which connects the control unit to the ion pump, can cause severe injury or death. Before mounting the high voltage connector of the cable on the pump high voltage feedthrough, or before removing it, be sure the main power is removed from the control unit.

WARNING!



To avoid injury, never connect the high voltage to the pump before it is installed into the system and all the inlet flanges are properly connected or blanked off. Make sure that the pump is well connected to the grounded vacuum system.

WARNING!



Before removing the high voltage connector of the cable from the control unit, be sure the main power is removed from the control unit. Wait at least 10 seconds after removing the main power from the control unit, to allow capacitors to discharge completely.

To disconnect the coaxial high voltage cable from the controller, slide the safety locking sleeve (very little sleeve travel is required) from the control unit and at the same time pull on the male end of the cable connector to remove it from the socket on the control unit.

Safety Interlock

The VacIon Plus pump feedthrough in conjunction with the cable P/N 929-0705, -0707, 0708 and -0709, when used with the Agilent MidiVac, DUAL and 4UHV control units, allows the operation of the “High Voltage Cable Safety Interlock” feature.

When the high voltage cable connector is disconnected from the VacIon Plus pump feedthrough, the high voltage is automatically switched off by the control unit.

Heater Installation

The heating element is a coaxial resistance heater shaped to fit the bottom of the pump body.

To install the element proceed as follows (Fig. 19):

- 1 Disassemble half of the cover by loosening the two screws;
- 2 Remove the pump from the magnet;

WARNING!



If some shock occur to the magnet assembly, when the pump is removed, the magnets can attract each other with the possibility of trapping fingers, shattering the magnets or damaging the equipment.

In order to avoid this insert a piece of wood or plastic in place of the pump body to keep the magnets separated.

-
- 3 Install the heater around the pump body;
 - 4 Reinstall the pump body and the cover.

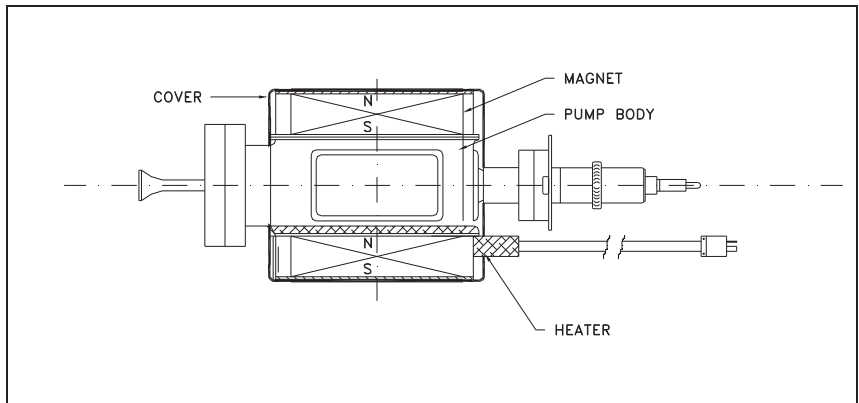

Figure 19 Heater element mounting (cover removed)

Heater Replacement

To replace the pump heaters, first remove the faulty heater following, in the reverse order, the instructions of the paragraph “HEATER INSTALLATION”, and then reassembly the new heater following the instructions of the above mentioned paragraph.

Bakeout Operation

When a VacIon pump does not reach the desired base pressure, and there are no leaks, it is necessary to bake the system. This is done by heating the pump and all the components in the system, and is generally required to achieve base pressure less than 10^{-8} mbar.

- 1 Heat the pump body and the system with a bakeout oven unit or heating strips to temperatures between 150 °C and 220 °C (220 °C is the maximum allowable for most bakeable high voltage cables). This temperature is high enough to degas the pump surfaces of water vapor without damaging the magnet and high voltage connector. Note that the system components must be compatible with the bakeout temperature. The heating must be approximately even on all surfaces or evaporated water will condense on the colder surfaces resulting in an incomplete bake and preventing achievement of UHV vacuum pressure.
- 2 Leave the pump control unit on and monitor the pressure. Agilent recommends that current during bake not exceed 50 mA; if this value is exceeded, turn the bakeout off and then on again when low pressure is restored.
To control the heaters and to monitor the high pressure limit during bakeout, an automatically controlled relay may be used.
- 3 Bake the VacIon Plus pump for at least 24 hours. Longer bakeout periods are recommended when the pump has been used with heavy gas loads or when UHV pressure, 10^{-9} mbar or less is desired.
- 4 As the pump and system cool down to room temperature, a drop in pressure should be observed.

Note that the ion pump can be also baked when switched off, into an external turbo pump through a bakeable isolation valve.

Bakeout of Vaclon Pump with the Integral Heaters

- 1 The integral heaters are to be powered with the appropriate voltage. (Please refer to the inscription on the heaters to apply correct voltage).
- 2 The integral heaters are designed to provide a temperature of 250 °C to 300 °C when the pump is wrapped in a 3-fold aluminium foil.

NOTE

A three-layer foil wrapping is advisable and sufficient to achieve full bakeout/regeneration if the standard European heaters (230 Vac) are operated at 240 Vac, thus preventing overheating.

-
- 3 Bakeout the Vaclon pump for 24 hours. If the pump is used in heavy gas load applications, it is recommended to bakeout the pump for a longer period.
 - 4 Wait until the pump cools down to room temperature and recovers its base pressure before using it in the application.

WARNING!

Do not touch the pump during the heating and cooling phases. The high temperature may cause serious damage.



Operating Procedure

- 1** Using a clean roughing pump, evacuate the system to a minimum starting pressure as stated by the technical specification. 10^{-6} mbar or less is recommended. To reach this pressure the use of an oil free turbo-molecular roughing pump is recommended.
- 2** When starting an ion pump, a slight increase in vacuum pressure is normal as the internal components are heated and outgassed. If possible leave the roughing pump connected to the system while starting the ion pump. This will make the startup faster and easier.
- 3** Connect the control unit to a suitable power source and switch the power on.
- 4** Switch on high voltage to the pump and observe the current and voltage. Fastest starting is obtained using a high applied voltage, 7 kilovolts for example. The applied voltage may be reduced later to optimize pumping and achieve the lowest vacuum pressure.
- 5** If started at 10^{-4} mbar, the voltage will start at approximately 800 volts and increase to full voltage as the pump starts operating. The current will start at several milliamps and slowly decrease to microamps or nanoamps as low vacuum pressure is achieved.
- 6** When first starting the pump, if the voltage de-creases instead of increasing, reduce the vacuum pressure then start the ion pump again.
- 7** When the pump reaches its full operating volt-age, you may close the roughing valve.
- 8** If the pump does not start after 30 minutes of pumping, see the section PUMP TROUBLE-SHOOTING.
- 9** Once the pump reaches its base pressure with stable voltage and current, the ion pump may be baked at high temperature if required per the section titled BAKEOUT OPERATION.
- 10** To stop the ion pump, simply switch off the high voltage. The pump surfaces will continue to pump for a few minutes depending on the system pressure.

- 11 When venting the pump use clean, dry nitrogen. This will avoid water absorption on the pump surfaces and make subsequent pump downs easier.

Maintenance

WARNING!



The high voltage present in the high voltage cable which connects the control unit to the ion pump, can cause severe injury or death. Before mounting the high voltage connector of the cable on the pump high voltage feedthrough, or before removing it, be sure the main power is removed from the control unit.

Before removing the high voltage connector of the cable from the control unit, be sure the main power is removed from the control unit. Wait at least 10 seconds after removing the main power from the control unit, to allow capacitors to discharge completely.

VacIon Plus pumps are maintenance free. In case of life time expiry or premature failure of the pump, please contact your nearest Agilent sales/service office for repair.

The VacIon Plus 20 pumps are designed with exchangeable high-voltage feedthrough and pump elements.

Exchange of the High Voltage Feedthrough

CAUTION!

The high voltage feedthrough contains a ceramic insulator that can be damaged if excessive force is applied in torque, in bending, or in tension. When installing or removing the feedthrough, the applied torque should not exceed 2 Nm. Rotate the feedthrough gently when making the threaded connection to avoid excessive force.

- 1 Remove the 6 bolts of the Mini-ConFlat flange connection (see Fig. 20).
- 2 Remove the cable connection disc.
- 3 Gently relieve the feedthrough from the metal gasket connection and turn the feedthrough counterclockwise until it is completely detached from the internal high voltage threaded connection.
- 4 Replace the feedthrough and the copper gasket, making sure that the feedthrough is connected to the pumps internal connector. Check that the feedthrough is not shorted.
- 5 Bake out the pump while it is operating, and leave it to cool down; then verify that the base pressure is below 10^{-9} mbar.

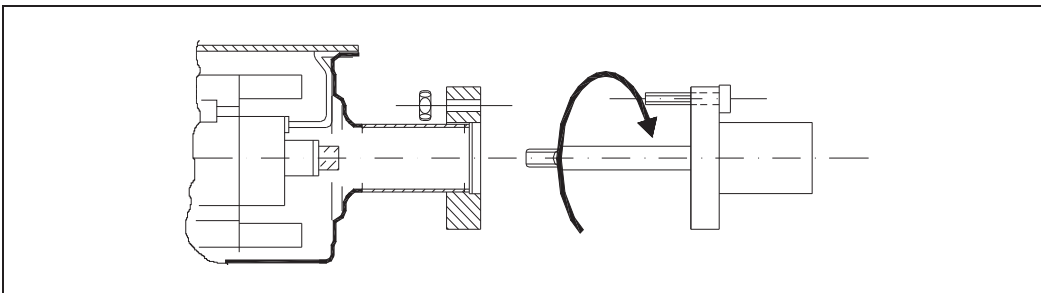

Figure 20 High voltage feedthrough connection

Leakage Current Check

If the pump current reading is to be used as pressure measurement, check the pump leakage currents as follows:

- 1** Turn off the pump control unit.
- 2** Remove the pump magnet.
- 3** Turn on the pump control unit and wait for current stabilization. The current reading should not be higher than 50 nA. Make sure that the control unit and the high voltage cable leakage current is negligible.
- 4** If leakage current comes from the pump, perform "high-potting" per the following procedure; then recheck the pump and install the magnet.
- 5** If it is not possible to "high-pot" the pump, the pressure reading is biased by the leakage current value.

High-potting

A constant pump current when no vacuum leak exists is often caused by field emission currents which prevent the use of the pump current as a UHV pressure indicator. To reduce this field emission current, "high-potting" should be performed. "High-potting" is the term used to describe the application of higher than normal operating voltage (8 kV AC, max. 50 mA) for the purpose of burning off "whiskers" (sharp edges) on the pump cathode.

High-potting should be done under vacuum and preferably without pump magnets installed (to reduce the drawn current).

High-potting must be done carefully and in voltage steps since uncontrolled arcing inside the pump can cause permanent damage. Therefore slowly increase the applied voltage and watch the current meter for indication of arcing inside the pump as whiskers are burned away. If arcing occurs wait at this voltage until the current is stable again. Then slowly increase voltage again in steps up to a maximum voltage. The maximum voltage may be applied to the pump for a period of about 15 seconds. This should effectively remove any "whiskers" or sharp edges on the pump cathode.

WARNING!



Voltages developed in the High Potter power supply are potentially lethal. Use caution during operation and ensure correct grounding connection.

Pump Troubleshooting

Tab. 2

Symptom	Possible cause	Correction procedure
1) – Slow starting	Starting vacuum pressure too high.	Reduce pressure to 10 ⁻⁵ mbar recommended 10 ⁻⁴ mbar minimum.
2) – Slow starting (more than 30 minutes).	Air leaks which limit pressure to above 10 ⁻⁶ mbar and cause longer starting time.	Leak check the vacuum system with a helium leak detector.
3) – Slow pump-down due to long exposure of viton parts to air.	Viton releases considerable gas after long exposure to air. (A bell-jar system which reached 2 x 10 ⁻⁸ mbar in 24 hours after 30 minutes air exposure, will only reach 1 x 10 ⁻⁷ mbar in 24 hours after 20 hours air exposure).	With the system under vacuum, pump for several days, or heat to 100-150 °C for up to 15 hours.
4) – Slow pump-down due to absorption of vapours on pump and system walls.	Vapours and gases admitted to a system are absorbed on the walls of the system and pump. Subsequent reduction in pressure depends on the rate of depletion of this vapour. Heavy hydrocarbons are most troublesome because of their relative low vapour pressure and they are very difficult to remove, even by baking.	Bake the system walls, thereby accelerating the desorption process. Baking mobilizes the vapours so they can be cracked and pumped by discharge (see section "BAKEOUT OPERATION").
5) – Slow starting or slow pump-down.	High voltage feedthrough is leaking.	Replace the feedthrough.
6) – Current higher than expected at any given pressure.	Ion pump leakage current causing higher pressure reading.	Highpot the pump.

5 Technical Information

Vaclon Plus Pump Replacement Parts and Accessories

Symptom	Possible cause	Correction procedure
7) – System fails to achieve desired UHV vacuum pressure.	System not fully baked. Water vapor limits base pressure.	Bake the system walls, thereby accelerating the desorption process. Baking mobilizes the vapours so they can be cracked and pumped by discharge (see section “BAKEOUT OPERATION”).
8) – System fails to achieve desired UHV vacuum pressure.	System not appropriately cleaned for UHV. Excessive outgassing from walls limits base pressure.	Clean all components for UHV and bake the system again.

Vaclon Plus Pump Replacement Parts and Accessories

Tab. 3

	Part Number			
	Diode	Noble Diode	Starcell	Starcell with Sm-Co magnets
Basic pump	919-1115	919-1125	919-1145	919-1146
Cables and accessories				
HV radiation resistant cable with interlock			929-0705	
Replacement parts				
HV Feedthrough			959-5125	
Pump without magnets	919-1114	919-1124		919-1144
Ferrite magnets	919-0040	919-0039	919-0035	--
Samarium-Cobalt magnets	--	--	--	919-0036
Heaters (120V)			919-0044	
(220V)			919-0043	

Copper gasket for 2 3/4" inlet flange (10-pack, individually sealed)	FG-0275-CI
Nut and bolt set for 2 3/4" inlet flange, 1/4 – 28 x 1 1/4 (25-pack)	FB-0275-C12
Copper gasket for 1 1/3" CF feedthrough flange (10-pack, individually sealed)	FG-0133-CI
Nut and bolt set for 1 1/3" CF feedthrough flange, 8-32x3/4 (25-pack)	FB-0133-C

For a complete overview of Agilent's extensive vacuum product line, please refer to the Agilent Vacuum Catalogue.

VacIon Plus Pump Controllers

The following controller series are available to supply the VacIon Plus pumps:

- MiniVac
- Dual
- 4UHV

Please refer to the Agilent Vacuum Catalogue to choose the correct controller for each pump.

5 Technical Information
Vaclon Plus Pump Controllers



Agilent Technologies

Vacuum Products Division

Dear Customer,

Thank you for purchasing an Agilent vacuum product. At Agilent Vacuum Products Division we make every effort to ensure that you will be satisfied with the product and/or service you have purchased.

As part of our Continuous Improvement effort, we ask that you report to us any problem you may have had with the purchase or operation of our products. On the back side you find a Corrective Action request form that you may fill out in the first part and return to us.

This form is intended to supplement normal lines of communications and to resolve problems that existing systems are not addressing in an adequate or timely manner.

Upon receipt of your Corrective Action Request we will determine the Root Cause of the problem and take the necessary actions to eliminate it. You will be contacted by one of our employees who will review the problem with you and update you, with the second part of the same form, on our actions.

Your business is very important to us. Please, take the time and let us know how we can improve.

Sincerely,

Giampaolo LEVI

***Vice President and General Manager
Agilent Vacuum Products Division***

Note: Fax or mail the Customer Request for Action (see backside page) to Agilent Vacuum Products Division (Torino) – Quality Assurance or to your nearest Agilent representative for onward transmission to the same address.

CUSTOMER REQUEST FOR CORRECTIVE / PREVENTIVE / IMPROVEMENT ACTION

TO: AGILENT VACUUM PRODUCTS DIVISION TORINO – QUALITY ASSURANCE

FAX N°: XXXX-011-9979350

ADDRESS: AGILENT TECHNOLOGIES ITALIA S.p.A. – Vacuum Products Division –
Via F.lli Varian, 54 – 10040 Leinì (TO) – Italy

E-MAIL: vpd-qualityassurance_pdl-ext@agilent.com

NAME _____	COMPANY _____	FUNCTION _____
ADDRESS: _____		
TEL. N° : _____ FAX N° : _____		
E-MAIL: _____		
PROBLEM / SUGGESTION : _____ _____ _____ _____		
REFERENCE INFORMATION (model n°, serial n°, ordering information, time to failure after installation, etc.): _____ _____ _____ DATE _____		
CORRECTIVE ACTION PLAN / ACTUATION (by AGILENT VPD) _____ _____ _____ _____ _____		LOG N° _____

XXX = Code for dialing Italy from your country (es. 01139 from USA; 00139 from Japan, etc.)





**Vacuum Products Division
Instructions for returning products**

Dear Customer:

Please follow these instructions whenever one of our products needs to be returned.

- 1) Complete the attached Request for Return form and send it to Agilent Technologies (see below), taking particular care to identify all products that have pumped or been exposed to any toxic or hazardous materials.
- 2) After evaluating the information, Agilent Technologies will provide you with a Return Authorization (RA) number via email or fax, as requested.
Note: Depending on the type of return, a Purchase Order may be required at the time the Request for Return is submitted. We will quote any necessary services (evaluation, repair, special cleaning, eg).
- 3) **Important steps for the shipment of returning product:**
 - Remove all accessories from the core product (e.g. inlet screens, vent valves).
 - Prior to shipment, drain any oils or other liquids, purge or flush all gasses, and wipe off any excess residue.
 - If ordering an Advance Exchange product, please use the packaging from the Advance Exchange to return the defective product.
 - Seal the product in a plastic bag, and package product carefully to avoid damage in transit. You are responsible for loss or damage in transit.
 - Agilent Technologies is not responsible for returning customer provided packaging or containers.
 - **Clearly label package with RA number.** Using the shipping label provided will ensure the proper address and RA number are on the package. Packages shipped to Agilent without a RA clearly written on the outside cannot be accepted and will be returned.
- 4) Return only products for which the RA was issued.
- 5) **Product being returned under a RA must be received within 15 business days.**
- 6) **Ship to the location specified on the printable label, which will be sent, along with the RA number, as soon as we have received all of the required information.** Customer is responsible for freight charges on returning product.
- 7) Return shipments must comply with all applicable **Shipping Regulations** (IATA, DOT, etc.) and carrier requirements.

RETURN THE COMPLETED REQUEST FOR RETURN FORM TO YOUR NEAREST LOCATION:

EUROPE:	NORTH AMERICA:	PACIFIC RIM:
Fax: 00 39 011 9979 330	Fax: 1 781 860 9252	please visit our website for individual
Fax Free: 00 800 345 345 00	Toll Free: 800 882 7426, Option 3	office information
Toll Free: 00 800 234 234 00	vpl-ra@agilent.com	http://www.agilent.com
vpt-customer@agilent.com		



Please read important policy information on Page 3 that applies to all returns.

1) CUSTOMER INFORMATION

Form with fields: Company Name, Contact Name, Tel, Email, Fax, Customer Ship To, Customer Bill To, Europe only: VAT reg. Number, USA/Canada only: Taxable, Non-taxable

2) PRODUCT IDENTIFICATION

Table with 4 columns: Product Description, Agilent P/N, Agilent S/N, Original Purchasing Reference

3) TYPE OF RETURN (Choose one from each row and supply Purchase Order if requesting a billable service)

- 3A. Non-Billable, Billable, New PO # (hard copy must be submitted with this form)
3B. Exchange, Repair, Upgrade, Consignment/Demo, Calibration, Evaluation, Return for Credit

4) HEALTH and SAFETY CERTIFICATION

AGILENT TECHNOLOGIES CANNOT ACCEPT ANY PRODUCTS CONTAMINATED WITH BIOLOGICAL OR EXPLOSIVE HAZARDS, RADIOACTIVE MATERIAL, OR MERCURY AT ITS FACILITY. Call Agilent Technologies to discuss alternatives if this requirement presents a problem. The equipment listed above (check one): HAS NOT pumped or been exposed to any toxic or hazardous materials. OR HAS pumped or been exposed to the following toxic or hazardous materials. List all toxic/hazardous materials. Include product name, chemical name, and chemical symbol or formula: NOTE: If a product is received at Agilent which is contaminated with a toxic or hazardous material that was not disclosed, the customer will be held responsible for all costs incurred to ensure the safe handling of the product, and is liable for any harm or injury to Agilent employees as well as to any third party occurring as a result of exposure to toxic or hazardous materials present in the product. Print Name: Authorized Signature: Date:

5) FAILURE INFORMATION:

Failure Mode (REQUIRED FIELD. See next page for suggestions of failure terms):
Detailed Description of Malfunction: (Please provide the error message)
Application (system and model):

I understand and agree to the terms of Section 6, Page 3/3.
Print Name: Authorized Signature: Date:



Please use these Failure Mode to describe the concern about the product on Page 2.

TURBO PUMPS and TURBO CONTROLLERS

APPARENT DEFECT/MALFUNCTION	POSITION	PARAMETERS
- Does not start - Does not spin freely - Does not reach full speed - Mechanical Contact - Cooling defective	- Noise - Vibrations - Leak - Overtemperature - Clogging	- Vertical - Horizontal - Upside-down - Other:
		Power: Rotational Speed: Current: Inlet Pressure: Temp 1: Foreline Pressure: Temp 2: Purge flow: OPERATING TIME:

ION PUMPS/CONTROLLERS

- Bad feedthrough	- Poor vacuum
- Vacuum leak	- High voltage problem
- Error code on display	- Other

VALVES/COMPONENTS

- Main seal leak	- Bellows leak
- Solenoid failure	- Damaged flange
- Damaged sealing area	- Other

LEAK DETECTORS

- Cannot calibrate	- No zero/high background
- Vacuum system unstable	- Cannot reach test mode
- Failed to start	- Other

INSTRUMENTS

- Gauge tube not working	- Display problem
- Communication failure	- Degas not working
- Error code on display	- Other

SCROLL AND ROTARY VANE PUMPS

- Pump doesn't start	- Noisy pump (describe)
- Doesn't reach vacuum	- Over temperature
- Pump seized	- Other

DIFFUSION PUMPS

- Heater failure	- Electrical problem
- Doesn't reach vacuum	- Cooling coil damage
- Vacuum leak	- Other

Section 6) **ADDITIONAL TERMS**

Please read the terms and conditions below as they apply to all returns and are in addition to the Agilent Technologies Vacuum Product Division – Products and Services Terms of Sale.

- Customer is responsible for the freight charges for the returning product. Return shipments must comply with all applicable **Shipping Regulations** (IATA, DOT, etc.) and carrier requirements.
- Customers receiving an Advance Exchange product agree to return the defective, rebuildable part to Agilent Technologies **within 15 business days**. Failure to do so, or returning a non-rebuildable part (crashed), will result in an invoice for the non-returned/non-rebuildable part.
- Returns for credit toward the purchase of new or refurbished Products are subject to prior Agilent approval and may incur a restocking fee. Please reference the original purchase order number.
- Units returned for evaluation will be evaluated, and a quote for repair will be issued. If you choose to have the unit repaired, the cost of the evaluation will be deducted from the final repair pricing. A Purchase Order for the final repair price should be issued within 3 weeks of quotation date. Units without a Purchase Order for repair will be returned to the customer, and the evaluation fee will be invoiced.
- A Special Cleaning fee will apply to all exposed products per Section 4 of this document.
- If requesting a calibration service, units must be functionally capable of being calibrated.

Sales and Service Offices

United States

**Agilent Technologies
Vacuum Products Division**
121 Hartwell Avenue
Lexington, MA 02421 - USA
Tel.: +1 781 861 7200
Fax: +1 781 860 5437
Toll-Free: +1 800 882 7426

Benelux

**Agilent Technologies Netherlands B.V.
Vacuum Products Division**
Herculesweg 8
4338 PL Middelburg
The Netherlands
Tel.: +31 118 671570
Fax: +31 118 671569
Toll-Free: 00 800 234 234 00

Canada

**Central coordination through: Agilent Technologies
Vacuum Products Division**
121 Hartwell Avenue
Lexington, MA 02421 - USA
Tel.: +1 781 861 7200
Fax: +1 781 860 5437
Toll-Free: +1 800 882 7426

China

**Agilent Technologies (China) Co. Ltd
Vacuum Products Division**
No.3, Wang Jing Bei Lu,
Chao Yang District,
Beijing, 100102
China
Tel.: +86 (10) 6439 7718
Toll-Free: 800 820 6556

France

**Agilent Technologies France
Vacuum Products Division**
7 Avenue des Tropiques
Z.A. de Courtaboeuf - B.P. 12
91941 Les Ulis cedex - France
Tel.: +33 (0) 1 69 86 38 84
Fax: +33 (0) 1 69 86 29 88
Toll free: 00 800 234 234 00

Germany and Austria

**Agilent Technologies
Vacuum Products Division**
Alsfelder Strasse 6 Postfach 11
14 35
64289 Darmstadt – Germany
Tel.: +49 (0) 6151 703 353
Fax: +49 (0) 6151 703 302
Toll free: 00 800 234 234 00

India

**Agilent Technologies India Pvt. Ltd.
Vacuum Product Division**
G01. Prime corporate Park,
230/231, Sahar Road, Opp. Blue Dart Centre,
Andheri (East), Mumbai – 400 099.India
Tel: +91 22 30648287/8200
Fax: +91 22 30648250
Toll Free: 1800 113037

Italy

**Agilent Technologies Italia S.p.A.
Vacuum Products Division**
Via F.lli Varian, 54
10040 Leini, (Torino) - Italy
Tel.: +39 011 997 9111 Fax: +39 011 997 9350
Toll-Free: 00 800 234 234 00

Japan

**Agilent Technologies Japan, Ltd.
Vacuum Products Division**
8th Floor Sumitomo Shibaura Building
4-16-36 Shibaura Minato-ku Tokyo 108-0023 - Japan
Tel.: +81 3 5232 1253
Fax: +81 3 5232 1710
Toll-Free: 0120 655 040

Korea

**Agilent Technologies Korea, Ltd.
Vacuum Products Division**
Shinsa 2nd Bldg. 2F 966-5 Daechi-dong
Kangnam-gu, Seoul
Korea 135-280
Tel.: +82 2 3452 2452
Fax: +82 2 3452 2451
Toll-Free: 080 222 2452

Mexico

**Agilent Technologies
Vacuum Products Division**
Concepcion Beistegui No 109 Col Del Valle
C.P. 03100 – Mexico, D.F.
Tel.: +52 5 523 9465
Fax: +52 5 523 9472

Singapore

**Agilent Technologies Singapore Pte. Ltd,
Vacuum Products Division**
Agilent Technologies Building,
1 Yishun Avenue 7,
Singapore 768923
Tel : (65) 6215 8045
Fax : (65) 6754 0574

Southeast Asia

**Agilent Technologies Sales Sdn Bhd
Vacuum Products Division**
Unit 201, Level 2 uptown 2,
2 Jalan SS21/37, Damansara Uptown
47400 Petaling Jaya,
Selangor, Malaysia
Tel : +603 7712 6106
Fax: +603 6733 8121

Taiwan

**Agilent Technologies Taiwan Limited
Vacuum Products Division (3F)**
20 Kao-Shuang Rd.,
Pin-Chen City, 324
Taoyuan Hsien , Taiwan, R.O.C.
Tel. +886 34959281
Toll Free: 0800 051 342

UK and Ireland

**Agilent Technologies UK, Ltd.
Vacuum Products Division**
6 Mead Road Oxford Industrial Park
Yarnton, Oxford OX5 1QU – UK
Tel.: +44 (0) 1865 291570
Fax: +44 (0) 1865 291571
Toll free: 00 800 234 234 00

Other Countries

**Agilent Technologies Italia S.p.A.
Vacuum Products Division**
Via F.lli Varian, 54 10040 Leini, (Torino) -
Italy
Tel.: +39 011 997 9111
Fax: +39 011 997 9350
Toll-Free: 00 800 234 234 00

Customer Support & Service

NORTH AMERICA:

Toll Free: 800 882 7426, Option 3
vpl-ra@agilent.com

EUROPE:

Toll Free: 00 800 234 234 00
vpt-customer@agilent.com

PACIFIC RIM:

please visit our website for individual office
information <http://www.agilent.com>

Worldwide Web Site, Catalog and Order On-line:

www.agilent.com
Representative in most countries
12/10

© Agilent Technologies, Inc. 2011

Printed in ITALY
05/2011
Publication Number: 87-900-106-01 (E)



Agilent Technologies