

PT

**Turbomolecular
Pump Systems**

30 - 400 l · s⁻¹

Calibration Systems

178.01.02

Excerpt from the Oerlikon Leybold Vacuum Full Line Catalog

Product Section C10

Edition 2010

Contents

General

General	C10.03
Applications and Accessories	C10.03

Products

Global Versions

Turbomolecular Pump Systems	
Oil sealed	
PT 50	C10.04
PT 151 / PT 361	C10.08
PT 50 KIT	C10.12
PT 151 / PT 361 KIT	C10.12
Dry	
PT 80 Dry	C10.14
TURBOLAB 80	C10.16
PT 151 Dry / PT 361 Dry	C10.20
PT 300 Dry	C10.22
CS Calibration Systems	C10.24

Accessories

Control Unit for Turbomolecular Pump Systems	C10.26
Adsorption Traps with Aluminium Oxide Insert	C10.27

Products

Versions for the North and South American Continents

Turbomolecular Pump Systems	
PT-Flex	C10.28

Accessories

TSC - TurboSystem Controller	C10.32
TPC - TurboPump Controller	C10.34

General

The requirements of production or research engineers concerning the vacuum technology they have to employ are usually widely different. In most cases pumping speed and operating pressure must be accurately matched to suit a particular process. The wide range of vacuum pumps and standard accessories available offers many options.

Sometimes it is just this flexibility which causes difficulties when having to decide between the various configurations of a particular pump system. Based on our experience and by listening to our customers' demands, we have therefore compiled a range of turn-key vacuum systems based on standard components. Before leaving the factory they are subjected to both functional

tests and leak tests. By adding components from our standard range of accessories they may be easily adapted to meet specific requirements.

Application and Accessories

Pump systems	Pump systems										
	PT 50	PT 151 / PT 361	PT 50 KIT	PT 151 KIT	PT 361 Kit	TURBOLAB 80	PT 151 Dry	PT 361 Dry	PT 300 Dry	PT-Flex	
Application											
Microbalances	■	■	■	■	■	■	■	■	■	■	■
Sputtering	■	■	■	■	■	■	■	■	■	■	■
Spectroscopy	■	■	■	■	■	■	■	■	■	■	■
Production of TV and monitor picture tubes	■	■	■	■	■	■	■	■	■	■	■
Surface refining	■	■	■	■	■	■	■	■	■	■	■
Evaporation coating systems	■	■	■	■	■	■	■	■	■	■	■
Beam guidance systems	■	■	■	■	■	■	■	■	■	■	■
Laboratory pump systems	■	■	■	■	■	■	■	■	■	■	■
Accessories											
	Page										
Control unit for turbomolecular pump systems	-	■	■			■		■	■	■	■
Air cooling unit	-	■	■	■	■	■		■	■	■	■
Flange heater	-	■	■	■	■	■		■	■	■	■
Venting valve	-	■	■	■	■	■	■	■	■	■	■
Power failure venting valve	-	■	■	■	■	■		■	■	■	■
Purge gas and venting valve	-		■		■			■	■	■	■
Adsorption traps with aluminium oxide insert	C10.26	■	■	■	■	■					■
Exhaust filter	-	■	■	■	■	■					■
Water cooling unit	-			■		■				■	

Products

Oil Sealed Pump Systems

PT 50 Turbomolecular Pump System



This turbomolecular pump system is a fully assembled and ready-to-operate ultra high vacuum system as a table top unit for processes which require hydrocarbon-free high and ultra high vacuum.

Advantages to the User

- High effective pumping speed
- Low ultimate pressure ($< 10^{-8}$ mbar ($< 0.75 \times 10^{-8}$ Torr))
- High pumping speed of the backing pump
- Compact, small, rugged unit
- Simple to operate
- High level of reliability
- Maintenance-friendly design
- For use world-wide
- Installation of standard vacuum components in an open frame
- Components such as the backing pump, frequency converter, vacuum gauge and power failure venting valve are controlled via a rotary switch
- Service friendly assembly for maintenance without the need to disassemble backing or high vacuum pump
- The high vacuum pump can be removed from the pump system
- CE approval

The turbomolecular pump system consists of the following principal components:

- Grease lubricated turbomolecular pump TURBOVAC 50 with ceramic ball bearings, convection cooling and splinter guard
- Electronic frequency converter NT 10
- Dual-stage, oil sealed rotary vane vacuum pump TRIVAC D 2,5 E as backing pump
- Switchbox with rotary switch for driving the backing pump, the turbomolecular pump, a vacuum gauge (optional) and a power failure venting valve (optional)
- Mains connection 230 V, 50 Hz with EURO plug
- Rugged table top unit which may also carry heavy assemblies
- All required connecting and sealing components are located within the pump system assembly

The pump system is prepared for installation of further components:

- Vacuum gauge
- Power failure venting valve
- Air cooling unit
- Assembly on the intake side with manifold, valves, gauge heads etc.
- Adsorption trap
- Exhaust filter
- Rotatable castors
- Mains cable with connection plug for UK, US, Switzerland, Japan

Typical Applications

- Spectroscopy
- Tube manufacturing
- Beam guidance systems
- Micro balances
- Sputtering and evaporation systems
- Surface physics
- Laboratory pump systems
- Production of gas Lasers

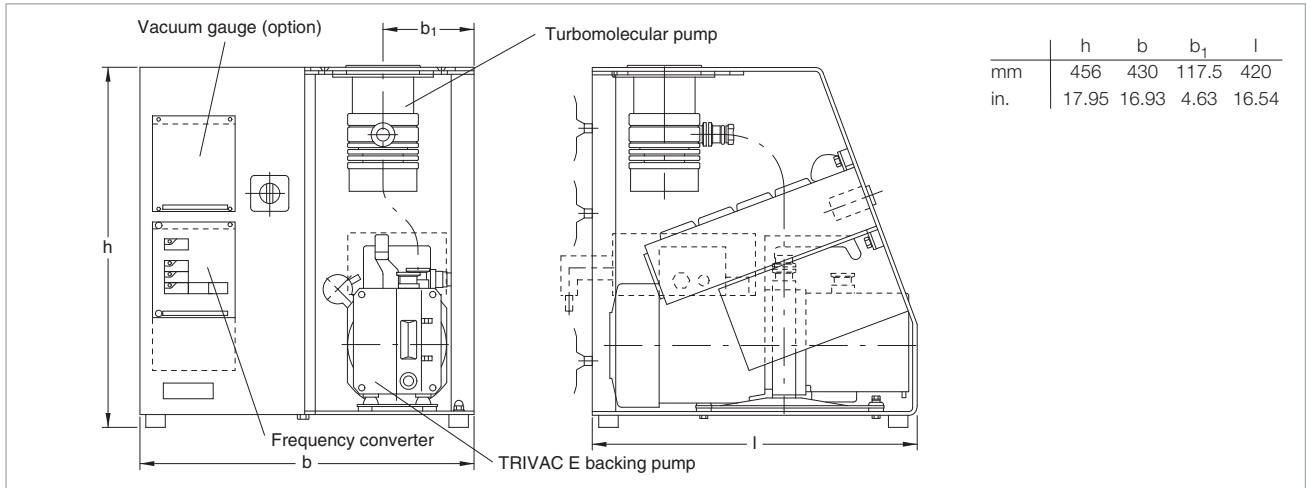

Dimensional drawing for the PT 50 turbomolecular pump system

Technical Data

PT 50

Turbomolecular pump		TURBOVAC 50	TURBOVAC 50	TURBOVAC 50
High vacuum connection	DN	40 KF	63 ISO-K	63 CF
Pumping speed for N ₂	l x s ⁻¹	33	55	55
Compression for N ₂ / H ₂		2 x 10 ⁷ / 10 ²	2 x 10 ⁷ / 10 ²	2 x 10 ⁷ / 10 ²
Speed of the TURBOVAC	rpm	72 000	72 000	72 000
Dual-stage rotary vane vacuum pump		TRIVAC D 2,5 E	TRIVAC D 2,5 E	TRIVAC D 2,5 E
nominal pumping speed				
acc. to PNEUROP	m ³ x h ⁻¹ (cfm)	2.7 (1.6)	2.7 (1.6)	2.7 (1.6)
Ultimate total pressure	mbar (Torr)	10 ⁻³ (0.75 x 10 ⁻³)	10 ⁻³ (0.75 x 10 ⁻³)	10 ⁻³ (0.75 x 10 ⁻³)
Attainable ultimate pressure				
with FPM (FKM) gasket	mbar (Torr)	10 ⁻⁷ (0.75 x 10 ⁻⁷)	10 ⁻⁷ (0.75 x 10 ⁻⁷)	10 ⁻⁷ (0.75 x 10 ⁻⁷)
with aluminum or Cu gasket ¹⁾	mbar (Torr)	–	–	10 ⁻⁹ (0.75 x 10 ⁻⁹)
Main supply, 50/60 Hz	V	100-120 / 200-240 ± 5%	100-120 / 200-240 ± 5%	100-120 / 200-240 ± 5%
Rated power consumption, approx.	VA	500	500	500
Dimensions (W x H x D)	mm (in.)	430 x 456 x 420 (16.93 x 17.95 x 16.54)	430 x 456 x 420 (16.93 x 17.95 x 16.54)	430 x 456 x 420 (16.93 x 17.95 x 16.54)
Weight, approx.	kg (lbs)	27 (59.4)	27 (59.4)	27 (59.4)

¹⁾ use only for CF flanges

Ordering Information

PT 50

PT 50 turbomolecular pump system DN 40 KF DN 63 ISO-K DN 63 CF	Part No. 128 80 - -	- Part No. 128 81 -	- - Part No. 128 83
Air cooling unit 100 V 115 V 230 V	- Part No. 854 06 Part No. 854 05	Part No. 800152V0015 Part No. 854 06 Part No. 854 05	Part No. 800152V0015 Part No. 854 06 Part No. 854 05
Flange heater DN 63 CF, 115 V DN 63 CF, 230 V	Part No. 854 07 Part No. 854 04	Part No. 854 07 Part No. 854 04	Part No. 854 07 Part No. 854 04
Venting valve, DN 10 KF manually operated	Part No. 173 24	Part No. 173 24	Part No. 173 24
Power failure venting valve, DN 10 KF 24 V DC 230 V, 50/60 Hz	Part No. 174 46 Part No. 174 26	Part No. 174 46 Part No. 174 26	Part No. 174 46 Part No. 174 26
Adsorption trap, DN 16 KF Adsorbent	Part No. 854 14 Part No. 854 10	Part No. 854 14 Part No. 854 10	Part No. 854 14 Part No. 854 10
Exhaust filter AF 8	Part No. 190 50	Part No. 190 50	Part No. 190 50
Mains cord US/Japan 115 V, 50/60 Hz US/Japan 230 V, 50/60 Hz CH 230 V, 50/60 Hz UK 230 V, 50/60 Hz	Part No. 200 81 090 Part No. 200 81 141 Part No. 200 81 099 Part No. 200 81 097	Part No. 200 81 090 Part No. 200 81 141 Part No. 200 81 099 Part No. 200 81 097	Part No. 200 81 090 Part No. 200 81 141 Part No. 200 81 099 Part No. 200 81 097
Connecting cable for operating the TURBOVAC outside the pump system 3 m (7.0 ft) 5 m (17.5 ft) 10 m (35.0 ft) 15 m (52.5 ft)	Part No. 121 08 Part No. 121 09 Part No. 161 10 Part No. 119 90	Part No. 121 08 Part No. 121 09 Part No. 161 10 Part No. 119 90	Part No. 121 08 Part No. 121 09 Part No. 161 10 Part No. 119 90
Control unit for turbomolecular pump systems (see Section "Accessories")			

PT 151/PT 361 Turbomolecular Pump Systems



These turbomolecular pump systems are ready-to-operate vacuum units for generating a vacuum in the high and ultra-high vacuum range which is free of hydrocarbons.

When pumping aggressive or abrasive process gases, a purge gas facility must be used for the pumps.

Advantages to the User

- Low ultimate pressure ($< 10^{-7}$ mbar /Torr), free of hydrocarbons
- High effective pumping speed
- Compact, mobile unit
- Simple to operate
- High level of reliability
- Purge gas and venting ports
- Components such as backing pump, frequency converter and TURBOVAC, as well as venting or degassing are controlled via a single multi function switch
- Service friendly assembly for maintenance without the need to disassemble backing or high vacuum pump
- Pump systems prepared for installation of larger backing pumps (for barrier gas operation, for example)
- Additional mains sockets for accessories
- CE approval

The turbomolecular pump systems consists of the following principal components:

- Grease lubricated turbomolecular pump TURBOVAC 151 or 361 with splinter guard
- Electronic frequency converter TD 20 classic
- Dual-stage, oil sealed TRIVAC D 4 B or D 16 B rotary vane vacuum pump as backing pump
- Switch box with mains power outlet and rotary switch to operate the connected units

The pump systems are prepared for installation of further components:

- Vacuum gauges (up to two):
- Adsorption trap
- Exhaust filter
- Air cooling unit
- Flange heater
- Venting valve

Typical Applications

- Spectroscopy
- Tube manufacturing
- Beam guidance systems
- Microbalances
- Sputtering and evaporation systems
- Surface physics

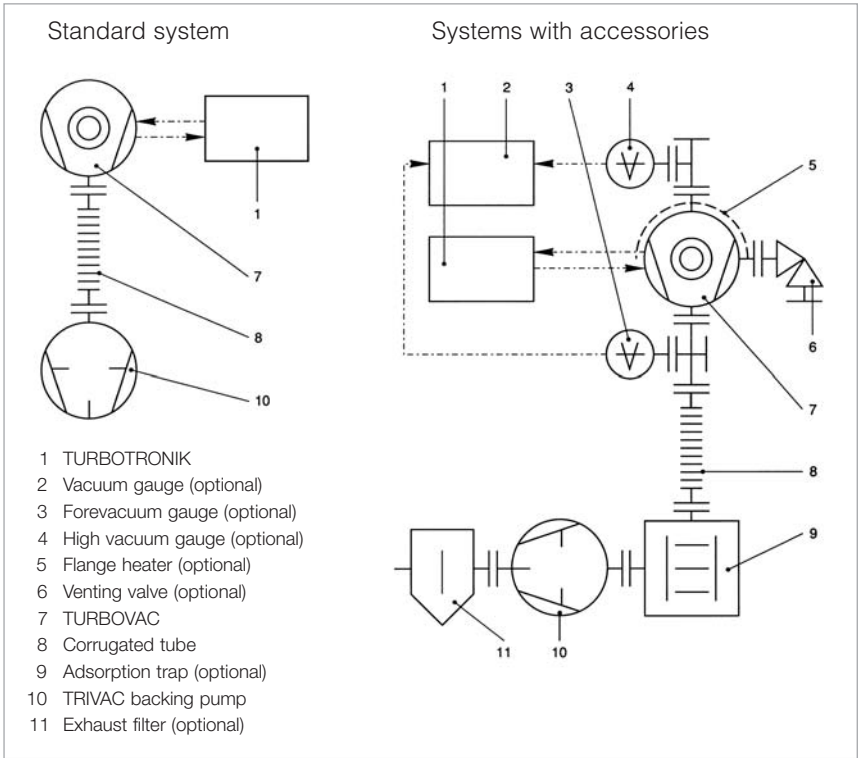

Vacuum diagram of the PT 151/PT 361 turbomolecular pump systems

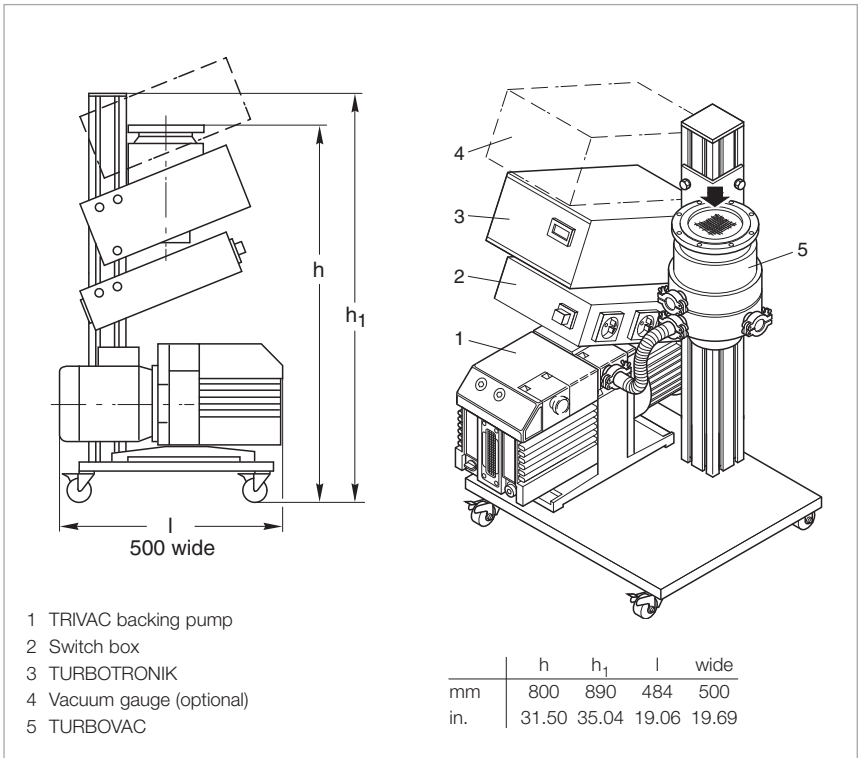

PT 151 turbomolecular pump system

Technical Data
PT 151
PT 361

		TURBOVAC 151	TURBOVAC 151	TURBOVAC 361	TURBOVAC 361
Turbomolecular pump					
High vacuum connection	DN	100 ISO-K	100 CF	100 ISO-K	100 CF
Pumping speed for N ₂	l x s ⁻¹	145	145	345	345
Compression for N ₂ /H ₂		> 10 ⁹	8.5 x 10 ²	> 10 ⁹	3.5 x 10 ³
Speed of the TURBOVAC	rpm	50000	50000	50000	50000
Dual-stage rotary vane vacuum pump		TRIVAC D 4 B	TRIVAC D 4 B	TRIVAC D 16 B	TRIVAC D 16 B
Nominal pumping speed (DIN 28 400)	m ³ x h ⁻¹ (cfm)	4.8 (2.83)	4.8 (2.83)	18.9 (11.13)	18.9 (11.13)
Exhaust connection	DN	16 KF	16 KF	25 KF	25 KF
Attainable ultimate pressure					
with FPM (FKM) gasket	mbar (Torr)	10 ⁻⁸ (0.75 x 10 ⁻⁸)	10 ⁻⁸ (0.75 x 10 ⁻⁸)	10 ⁻⁸ (0.75 x 10 ⁻⁸)	10 ⁻⁸ (0.75 x 10 ⁻⁸)
with Cu seal	mbar (Torr)	–	10 ⁻¹⁰ (0.75 x 10 ⁻¹⁰)	–	10 ⁻¹⁰ (0.75 x 10 ⁻¹⁰)
Cooling water consumption	l/h	20	20	20	20
Cooling water connection, hose nozzle, outside dia.	mm (in.)	11 (0.43)	11 (0.43)	11 (0.43)	11 (0.43)
Power consumption	kW	0.7	0.7	1.5	1.5
Main supply					
EURO version		230 V, 50 Hz	230 V, 50 Hz	230 V, 50 Hz	230 V, 50 Hz
US version		115 V, 60 Hz	115 V, 60 Hz	115 V, 60 Hz	115 V, 60 Hz
Dimensions (W x H x D)	mm (in.)	500 x 890 x 484 (19.69 x 35.04 x 19.06)	500 x 890 x 484 (19.69 x 35.04 x 19.06)	500 x 890 x 484 (19.69 x 35.04 x 19.06)	500 x 890 x 484 (19.69 x 35.04 x 19.06)
Weight, approx.	kg (lbs)	45 (99.2)	45 (99.2)	62 (136.7)	62 (136.7)

Ordering Information**PT 151****PT 361**

Turbomolecular pump system EURO version, 230 V / 50 Hz, Schuko plug DN 100 ISO-K DN 100 CF	Part No. 128 84	Part No. 128 86
	Part No. 128 85	Part No. 128 88
US version, 115 V / 60 Hz, US plug DN 100 ISO-K DN 100 CF	Part No. 152 57	Part No. 152 59
	Part No. 152 58	Part No. 152 60
Air cooling unit 100 V 115 V 230 V	Part No. 800152V0016	Part No. 800152V0016
	Part No. 894 08	Part No. 894 08
	Part No. 855 31	Part No. 855 31
Flange heater, DN 100 CF 115 V 230 V	Part No. 854 28	Part No. 854 28
	Part No. 854 27	Part No. 854 27
Venting valve, DN 10 KF manually operated	Part No. 173 24	Part No. 173 24
Power failure venting valve, DN 10 KF 24 V DC 230 V, 50/60 Hz	Part No. 174 46	Part No. 174 46
	Part No. 174 26	Part No. 174 26
Adsorption trap DN 16 KF DN 25 KF	Part No. 854 14	-
	-	Part No. 854 15
Adsorbent	Part No. 854 10	Part No. 854 10
Exhaust filter AF 4-8 AF 16-25	Part No. 189 06	-
	-	Part No. 189 11
Purge gas and venting valve, 230 V 0.2 mbar x l x s ⁻¹	Part No. 855 19	Part No. 855 19
Control unit for turbomolecular pump systems (see Section "Accessories")	upon request	upon request

Turbomolecular Pump Systems

PT 50 KIT, PT 151 KIT, PT 361 KIT

Under the motto “Do-it-yourself and save money” you may assemble the turbomolecular pump systems PT 50 KIT, PT 151 KIT and PT 361 KIT yourself.

The turbomolecular pump systems PT 50 KIT, PT 151 KIT and PT 361 KIT are made of the same components as used for the turn-key systems:

- Base panel with column
- Turbomolecular pump TURBOVAC 50 (PT 50 KIT) or 151 or 361 (PT 151 KIT or PT 361 KIT)
- Rotary vane vacuum pump TRIVAC D 2,5 E (PT 50 KIT) or D 4 B or D 16 B (PT 151 KIT or PT 361 KIT)
- TURBOTRONIK NT 10 electronic frequency converter (PT 50 KIT) or NT 20 (PT 151 KIT and PT 361 KIT)
- All necessary mounting parts, connection parts and gaskets are supplied
- Simple and accurate assembly instructions
- Detailed exploded view
- Description which is easy to understand
- Additional detailed knowledge is gained about the product by assembling it yourself
- CE approval

The technical data, the areas of application and the design characteristics correspond to the turbomolecular pump systems PT 50, PT 151 and PT 361 described on the preceding pages.

Typical Applications

- Spectroscopy
- Tube manufacturing
- Beam guidance systems
- Microbalances
- Sputtering and evaporation systems
- Surface physics
- Laboratory pump systems
- Production of gas lasers

PT 50 KIT



Unpacking, 15 minutes, approx.



After further 20 minutes



After further 20 minutes



After further 30 minutes

PT 151 KIT/PT 361 KIT

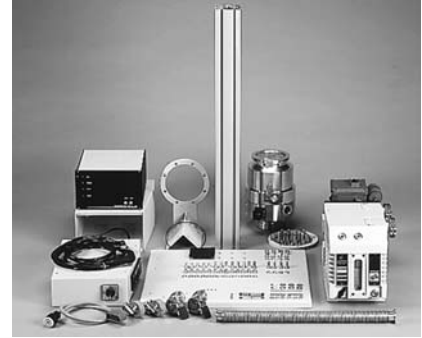

Unpacking, 15 minutes, approx.

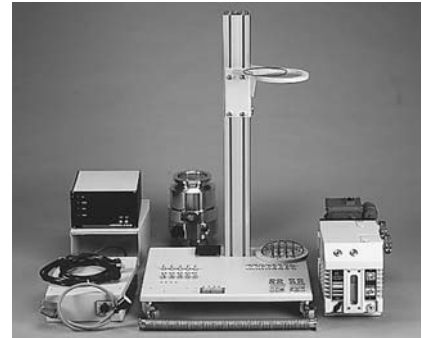

After further 30 minutes



After further 30 minutes



After further 50 minutes

Ordering Information

PT 50 KIT

PT 151 KIT

PT 361 KIT

PT 50 KIT turbomolecular pump system			
DN 40 KF	Part No. 128 70	-	-
DN 63 ISO-K	Part No. 128 71	-	-
DN 63 CF	Part No. 128 73	-	-
PT 151 KIT turbomolecular pump system, water-cooled			
DN 100 ISO-K	-	Part No. 128 74	-
DN 100 CF	-	Part No. 128 75	-
PT 361 KIT turbomolecular pump system, water-cooled			
DN 100 ISO-K	-	-	Part No. 128 76
DN 100 CF	-	-	Part No. 128 78
DN 160 ISO-K	-	-	upon request
DN 160 CF	-	-	upon request
Air cooling unit			
230 V	Part No. 854 05	Part No. 855 31	Part No. 855 31
115 V	Part No. 854 06	Part No. 894 08	Part No. 894 08
100 V	Part No. 800152V0015	Part No. 800152V0016	Part No. 800152V0016
Water cooling unit for the TURBOVAC	Part No. 800135V0003	-	-
Flange heater			
DN 63 CF, 230 V	Part No. 854 04	-	-
DN 63 CF, 115 V	Part No. 854 07	-	-
DN 100 CF, 230 V	-	Part No. 854 27	Part No. 854 27
DN 100 CF, 115 V	-	-	Part No. 854 28
Adsorption trap			
DN 16 KF	Part No. 854 14	Part No. 854 14	-
DN 25 KF	-	-	Part No. 854 15
Adsorbent	Part No. 854 10	Part No. 854 10	Part No. 854 10
Exhaust filter			
AF 4-8	-	Part No. 189 06	-
AF 8	Part No. 190 50	-	-
AF 16-25	-	-	Part No. 189 11
Venting valve, DN 10 KF manually operated	Part No. 173 24	Part No. 173 24	Part No. 173 24
Purge gas and venting valve, 230 V 0.2 mbar x l x s ⁻¹	-	Part No. 855 19	Part No. 855 19
Power failure venting valve, DN 10 KF			
24 V DC	Part No. 174 46	Part No. 174 46	Part No. 174 46
230 V, 50/60 Hz	Part No. 174 26	Part No. 174 26	Part No. 174 26
Water cooling unit for the TURBOVAC	Part No. 854 08	-	-
Mains cord			
US/Japan 115 V, 50/60 Hz	Part No. 200 81 090	-	-
US/Japan 230 V, 50/60 Hz	Part No. 200 81 141	Part No. 200 81 141	Part No. 200 81 141
CH 230 V, 50/60 Hz	Part No. 200 81 099	Part No. 200 81 099	Part No. 200 81 099
UK 230 V, 50/60 Hz	Part No. 200 81 097	Part No. 200 81 097	Part No. 200 81 097
Connecting cable for operating the TURBOVAC outside the pump system			
3 m (7.0 ft)	Part No. 121 08	-	-
5 m (17.5 ft)	Part No. 121 09	Part No. 857 66	Part No. 857 66
10 m (35.0 ft)	-	Part No. 857 67	Part No. 857 67

Dry Pump Systems

PT 80 Dry Turbomolecular Pump System



PT 80 Dry with diaphragm vacuum pump

The PT 80 Dry turbomolecular pump system is a fully assembled and ready-to-operate high vacuum system designed as a table top unit.



PT 80 Dry with scroll pump and options (measuring instrument, power failure venting valves and intake section)

Advantages to the User

- Absolutely oil-free
- Low ultimate pressure free of hydrocarbons (10^{-8} mbar/Torr)
- High effective pumping speed
- Compact, small unit
- Simple operation
- High level of reliability
- Maintenance-friendly design
- Air cooling
- Installation of standard vacuum components in an open frame
- Components such as the diaphragm backing pump and turbomolecular pump are controlled via switches
- Service-friendly assembly for maintenance without the need to disassemble backing or high vacuum pump
- The high vacuum pump can be removed (installation in any orientation)
- The pump systems are subjected to a full functional test and a leak test before delivery

The turbomolecular pump system consists of the following principal components:

- SL 80 wide range turbomolecular pump system featuring
- Integrated frequency converter
- Integrated air cooling

- Ceramic ball bearings
- Grease lubrication
- Pumping speed for nitrogen: 65 l x s^{-1}
- High vacuum connection: DN 63 ISO-K or DN 63 CF
- Integrated splinter guard
- TURBO.POWER 300 power supply. The power supply supplies the frequency converter with 24 V DC
- Dual-stage, absolutely oil-free DIVAC 0.8 T diaphragm vacuum pump used as the backing pump respectively scroll pump SCROLLVAC SC 5D as the backing pump
- All required connection and sealing components are located within the pump system assembly

The pump system is prepared for installation of further components.

- Vacuum gauges
- Venting valve / Power failure venting valve
- Junction box

Typical Applications

- Spectroscopy
- Valve manufacturing
- Beam guidance systems
- Micro balances
- Sputtering and evaporation systems
- Surface physics
- Laboratory pump systems

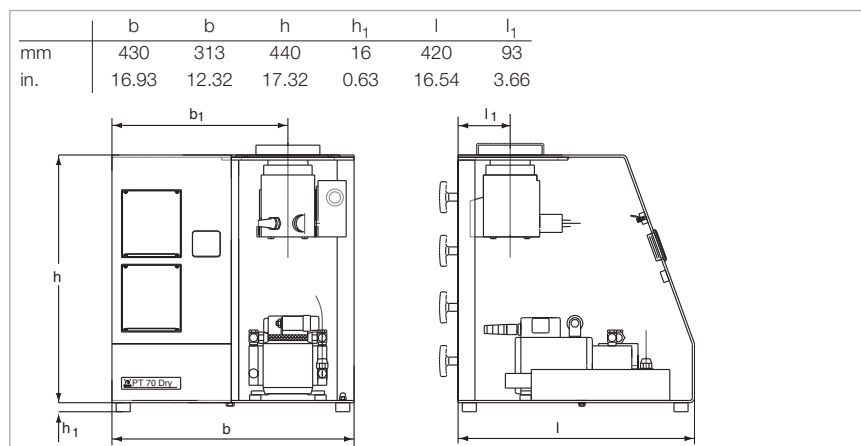

Dimensional drawing for the PT 80 Dry turbomolecular pump system

Technical Data

PT 80 Dry

Wide range turbomolecular pump		TURBO VAC SL 80	TURBO VAC SL 80
High vacuum connection	DN	63 ISO-K	63 CF
Pumping speed for N ₂	l x s ⁻¹	65	65
Diaphragm pump		DIVAC 0.8 T	DIVAC 0.8 T
Pumping speed, approx.	m ³ x h ⁻¹ (cfm)	0.6 (0.35)	0.6 (0.35)
Ultimate pressure, approx.	mbar (Torr)	< 3 (< 2.3)	< 3 (< 2.3)
Scroll vacuum pump		SCROLLVAC SC 5 D	SCROLLVAC SC 5 D
Pumping speed, approx.	m ³ x h ⁻¹ (cfm)	5.4 (3.18)	5.4(3.18)
Ultimate pressure, approx.	mbar (Torr)	< 0.05(0.03)	< 0.05(0.03)
Attainable ultimate pressure	mbar (Torr)	10 ⁻⁷ (0.75 x 10 ⁻⁷)	10 ⁻⁸ (0.75 x 10 ⁻⁸)
Main supply, 50/60 Hz	V	230 / 115	230 / 115
Rated power consumption, approx.			
with diaphragm vacuum pump	W	350	350
with scroll vacuum pump	W	450	450
Dimensions (W x H x D)	mm (in.)	430 x 456 x 420 (16.93 x 17.95 x 16.54)	430 x 456 x 420 (16.93 x 17.95 x 16.54)
Weight, approx.			
with diaphragm vacuum pump	W	20 (44.15)	20 (44.15)
with scroll vacuum pump	W	28(61.6)	28(61.6)

Ordering Information

PT 80 Dry

PT 80 Dry turbomolecular pump system with diaphragm vacuum pump, without switch box		
DN 63 ISO-K 230 V, 50 Hz	Part No. 502 500	-
DN 63 ISO-K 115 V, 60 Hz	upon request	-
DN 63 CF 230 V, 50 Hz	-	Part No. 502 501
DN 63 CF 115 V, 60 Hz	-	upon request
with scroll vacuum pump, switch box and EURO mains cord for switchbox		
DN 63 ISO-K 115/230 V, 50/60 Hz	upon request	upon request
DN 63 CF 115/230 V, 50/60 Hz	upon request	upon request
Switch box, without mains cord	Part No. 200 06 393	Part No. 200 06 393
Mains adapter Schuko/US	Part No. 200 11 119	Part No. 200 11 119
Mains cord for junction box		
EURO 230 V, 50 Hz	Part No. 200 81 091	Part No. 200 81 091
CH 230 V, 50/60 Hz	Part No. 200 81 099	Part No. 200 81 099
UK 230 V, 50/60 Hz	Part No. 200 81 097	Part No. 200 81 097
US/Japan 230 V, 50/60 Hz	Part No. 200 81 141	Part No. 200 81 141
US/Japan 115 V, 60 Hz	Part No. 200 81 090	Part No. 200 81 090
Power failure venting valve 230 V, 50/60 Hz	Part No. 174 26	Part No. 174 26
24 V DC mains cord		
3 m (7.0 ft)	Part No. 800094V0300	Part No. 800094V0300
5 m (17.5 ft)	Part No. 800094V0500	Part No. 800094V0500
10 m (35.0 ft)	Part No. 800094V1000	Part No. 800094V1000
20 m (70.0 ft)	Part No. 800094V2000	Part No. 800094V2000
Control unit for turbomolecular pump systems (see Section "Accessories")	upon request	upon request

Turbomolecular Pump System

TURBOLAB 80



Turbomolecular pump system TURBOLAB 80 Basic (left) and TURBOLAB 80 Full Featured (right)

The TURBOLAB 80 turbomolecular pump system is a fully assembled and ready-to-operate high vacuum system designed as a table top unit.

Advantages to the User

- Absolutely oil-free
- Low ultimate pressure free of hydrocarbons (10^{-8} mbar/Torr)
- High effective pumping speed
- Compact and small unit
- Simple operation
- High level of reliability
- Maintenance-friendly design
- Air cooling
- Installation of standard vacuum components in a portable sheet metal frame enclosure

Only TURBOLAB 80 Basic:

- Manual operation
- Pressure measurement as an option via ITR 90 with display

Only TURBOLAB 80 Full Featured:

- Graphic display of pressure curves
- Menu navigation in different languages
- Parameters of the turbomolecular pump and pressures can be saved to a computer
- PTR 90 or TTR 90 gauge heads can be connected
- Displaying pressures is possible
- Manual or automatic operation

- Operation parameter indication
- Forevacuum pressure measurement optional (possible)
- Venting is possible (optional)

The turbomolecular pump system consists of the following principal components:

- SL 80 wide range turbomolecular pump system featuring:
- Integrated frequency converter
- Integrated air cooling
- Ceramic ball bearings
- Grease lubrication

- Pumping speed for nitrogen: 65 l x s^{-1}

- High vacuum connection: DN 63 ISO-K or DN 63 CF

- Integrated splinter guard

- Dual-stage, absolutely oil-free DIVAC 0.8 T diaphragm vacuum pump used as the backing pump with the following specifications:

Pumping speed:
 $0.7 \text{ m}^3 \times \text{h}^{-1}$ (0.41 cfm)

Ultimate pressure:
 $\leq 3 \text{ mbar}$ ($\leq 2.25 \text{ Torr}$)

- All required connection and sealing components are located within the pump system assembly

The pump system is prepared for installation of further components:

- Vacuum gauges
- Venting valve

For operating the TURBOLAB 80 Full Featured version, an ITR 90 high vacuum gauge (without display) and a 5 m (17.5 ft) long sensor cable are needed.

The pressure is read out through the display of the pump system. The 24 V DC power supply for operating an ITR 90, respectively PTR 90 gauge is supplied by the pump system.

Typical Applications

- Spectroscopy
- Valve manufacturing
- Beam guidance systems
- Micro balances
- Sputtering and evaporation systems
- Surface physics
- Laboratory pump systems

Technical Data

TURBOLAB 80 Basic

TURBOLAB 80 Full Featured

Hybrid turbomolecular pump		TURBOVAC SL 80	TURBOVAC SL 80
High vacuum connection	DN	63 ISO-K / 63 CF	63 ISO-K / 63 CF
Pumping speed for N ₂	l x s ⁻¹	65	65
Diaphragm pump		DIVAC 0.8 T	DIVAC 0.8 T
Pumping speed, approx.	m ³ x h ⁻¹ (cfm)	0.7 (0.41)	0.7 (0.41)
Ultimate pressure, approx.	mbar (Torr)	3 (2.25)	3 (2.25)
Attainable ultimate pressure	mbar (Torr)	10 ⁻⁷ (0.75 x 10 ⁻⁷) / 10 ⁻⁸ (0.75 x 10 ⁻⁸)	10 ⁻⁷ (0.75 x 10 ⁻⁷) / 10 ⁻⁸ (0.75 x 10 ⁻⁸)
Run-up time, approx.	min	1.5	1.5
Main supply, 50/60 Hz	V	88 bis 264	88 bis 264
Rated power consumption, approx.	W	300	300
Dimensions (W x H x D)	mm (in.)	255 x 355 x 355 (10.04 x 13.98 x 13.98)	255 x 355 x 355 (10.04 x 13.98 x 13.98)
Weight, approx.	kg (lbs)	14.5 (32.01)	14.5 (32.01)

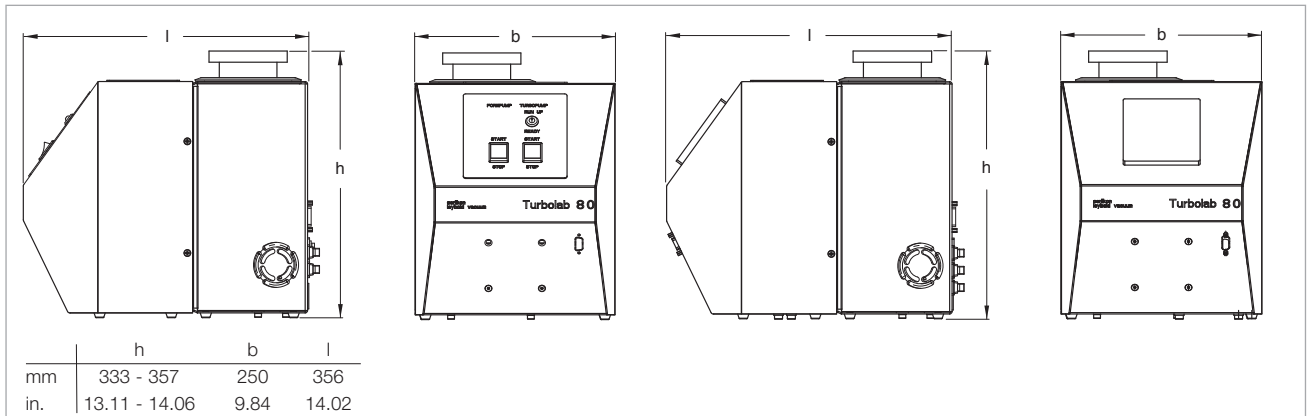

Dimensional drawing for the turbomolecular pump system TURBOLAB 80 Basic (left) and TURBOLAB 80 Full Featured (right)

Ordering Information

TURBOLAB 80 Basic

High vacuum connection

- DN 63 ISO-K
- DN 63 CF

Sensor

- without sensor
- ITR 90/DN 25 KF
- with display and 5 m (17.5 ft) cable
- ITR 90/DN 40 CF
- with display and 5 m (17.5 ft) cable

Venting valve

- without venting valve
- in the forevacuum line
- with venting valve
- in the forevacuum line

Part No. 501590

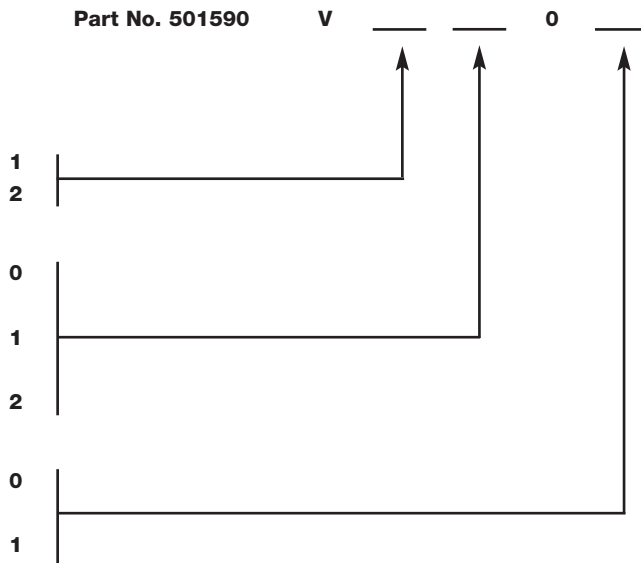

Ordering Information

TURBOLAB 80 Full Featured

High vacuum connection

- DN 63 ISO-K
- DN 63 CF

Sensor

- without sensor, without cable
- ITR 90/DN 25 KF
- with display and 5 m (17.5 ft) cable
- without display and 5 m (17.5 ft) cable
- ITR 90/DN 40 CF
- with display and 5 m (17.5 ft) cable
- without display and 5 m (17.5 ft) cable
- PTR 90/DN 25 KF
- with cable and adapter
- PTR 90/DN 40 KF
- with cable and adapter
- PTR 90/DN 40 CF
- with cable and adapter

Sensor TTR 91

- without sensor
- in the forevacuum line
- with sensor
- in the forevacuum line

Venting valve

- without venting valve
- in the forevacuum line
- with venting valve
- in the forevacuum line

Part No. 501591

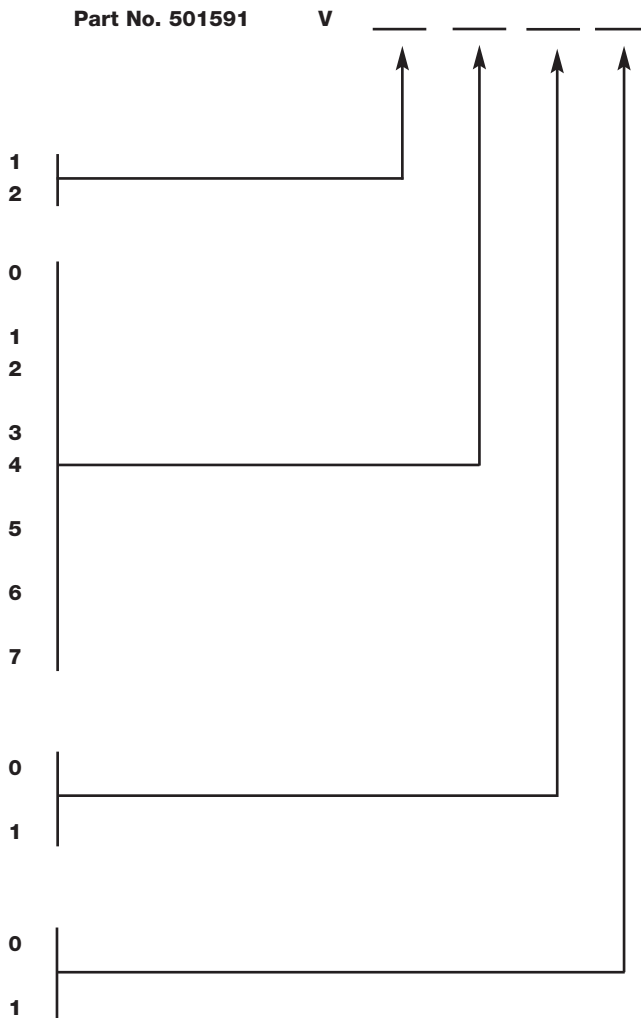

Parts for Converting/Expanding Existing Systems

Ordering Information Conversion	TURBOLAB 80 Basic	TURBOLAB 80 Full Featured
Venting valve 24 V DC, normally open	-	Part No. 500 004 590
Sensor TTR 90 1/2" Rohr	-	Part No. 230 039
Sensor ITR 90 DN 25 KF with display DN 40 CF with display ITR sensor cable, 5 m (17.5 ft)	Part No. 120 91 Part No. 120 94 Part No. 124 55	Part No. 120 91 Part No. 120 94 Part No. 124 55
Sensor PTR 90 DN 25 KF DN 40 KF DN 40 CF PTR sensor cable, 5 m (17.5 ft) ¹⁾ Adapter cable TURBOLAB 80/PTR sensor ¹⁾	- - - - -	Part No. 230 070 Part No. 230 071 Part No. 230 072 Part No. 124 26 Part No. 500 008 229

¹⁾ Required for fitting a PTR 90

PT 151 Dry / PT 361 Dry Turbomolecular Pump Systems



PT 361 Dry with scroll pump with options
(measuring instrument, forevacuum valve)

These turbomolecular pump systems are ready-to-operate vacuum units for generating a vacuum in the high and ultra-high vacuum range which is free of hydrocarbons.

When pumping aggressive or abrasive process gases, a purge gas facility must be used for the pumps.

Typical Applications

- Spectroscopy
- Tube manufacturing
- Beam guidance systems
- Microbalances
- Sputtering and evaporation systems
- Surface physics

Advantages to the User

- Low ultimate pressure (< 10^{-7} mbar /Torr), free of hydrocarbons
- High effective pumping speed
- Compact, mobile unit
- Simple to operate
- High level of reliability
- Purge gas and venting ports
- Components such as backing pump, frequency converter and TURBOVAC, as well as venting or degassing are controlled via a single multi function switch

- Service friendly assembly for maintenance without the need to disassemble backing or high vacuum pump
- Pump systems prepared for installation of larger backing pumps (for barrier gas operation, for example)
- Additional mains sockets for accessories
- CE approval

The turbomolecular pump systems consists of the following principal components:

- Grease lubricated turbomolecular pump TURBOVAC 151 or 361 with splinter guard

- Electronic frequency converter TD 20 classic
- Dry compressing scroll pump SCROLLVAC SC 15 D or SC 30 D
- Switch box with mains power outlet and rotary switch to operate the connected units

The pump systems are prepared for installation of further components:

- Vacuum gauges (up to two):
- Air cooling unit
- Flange heater
- Venting valve

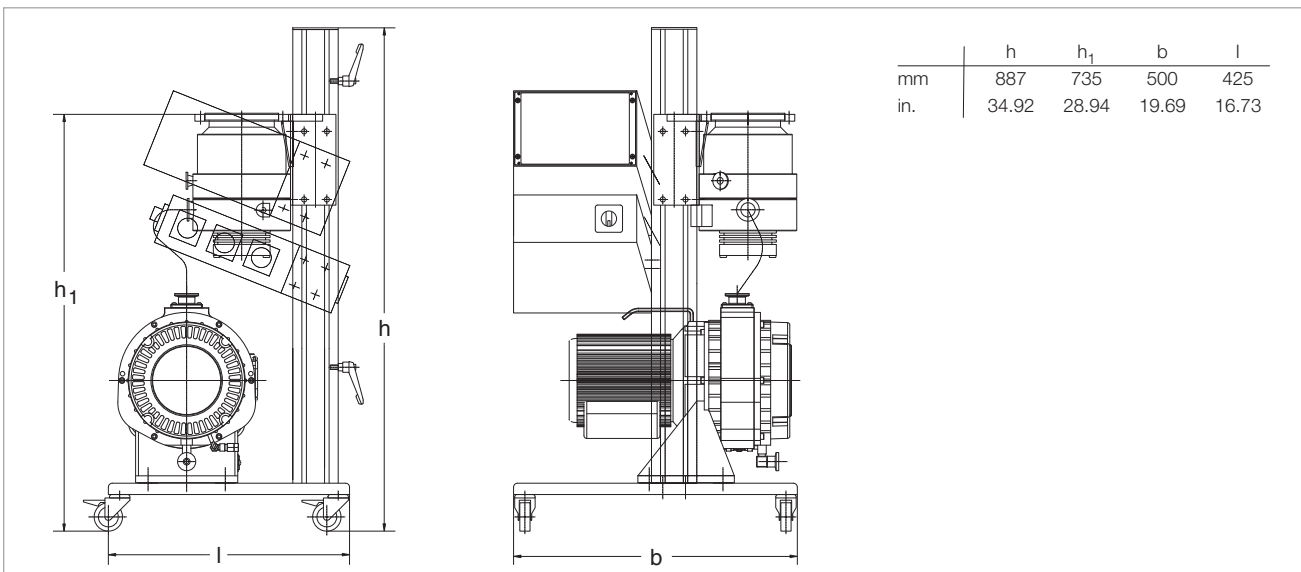

PT 151 / 361 Dry turbomolecular pump system with scroll vacuum pump SCROLLVAC

Technical Data

PT 151 Dry

PT 361 Dry

Turbomolecular pump	TURBOVAC	151	151	361	361
High vacuum connection	DN	100 ISO-K	100 CF	100 ISO-K	100 CF
Pumping speed for N ₂	l x s ⁻¹	145	145	345	345
Compression for N ₂ /H ₂		> 10 ⁹	8.5 x 10 ²	> 10 ⁹	3.5 x 10 ³
Speed of the TURBOVAC	rpm	50000	50000	50000	50000
Scroll vacuum pump	SCROLLVAC	SC 5 D	SC 5 D	SC 15 D	SC 15 D
Nominal pumping speed (DIN 28 400)	m ³ x h ⁻¹ (cfm)	15	15	30	30
Exhaust connection	DN	16 KF	16 KF	25 KF	25 KF
Attainable ultimate pressure with FPM (FKM) gasket	mbar (Torr)	10 ⁻⁸ (0.75 x 10 ⁻⁸)	10 ⁻⁸ (0.75 x 10 ⁻⁸)	10 ⁻⁸ (0.75 x 10 ⁻⁸)	10 ⁻⁸ (0.75 x 10 ⁻⁸)
with Cu seal	mbar (Torr)	–	10 ⁻¹⁰ (0.75 x 10 ⁻¹⁰)	–	10 ⁻¹⁰ (0.75 x 10 ⁻¹⁰)
Cooling water consumption	l/h	20	20	20	20
Cooling water connection, hose nozzle, outside dia.	mm (in.)	11 (0.43)	11 (0.43)	11 (0.43)	11 (0.43)
Power consumption	kW	0.7	0.7	1.5	1.5
Main supply					
EURO version		230 V, 50 Hz	230 V, 50 Hz	230 V, 50 Hz	230 V, 50 Hz
US version		115 V, 60 Hz	115 V, 60 Hz	115 V, 60 Hz	115 V, 60 Hz
Dimensions (W x H x D)	mm (in.)	500 x 890 x 484 (19.69 x 35.04 x 19.06)	500 x 890 x 484 (19.69 x 35.04 x 19.06)	500 x 890 x 484 (19.69 x 35.04 x 19.06)	500 x 890 x 484 (19.69 x 35.04 x 19.06)
Weight, approx.	kg (lbs)	51 (112.6)	51 (112.6)	80 (176.6)	80 (176.6)

Ordering Information

PT 151 Dry

PT 361 Dry

Turbomolecular pump system 230 V, 50/60 Hz / 115 V, 60 Hz with Schuko plug DN 100 ISO-K DN 100 CF	Part No. 502 440 Part No. 502 441	Part No. 502 442 Part No. 502 443
Mains cord CH 230 V, 50 Hz UK 230 V, 50/60 Hz US/Japan 230 V, 50/60 Hz US/Japan 115 V, 60 Hz	Part No. 200 81 099 Part No. 200 81 097 Part No. 200 81 141 Part No. 200 81 090	Part No. 200 81 099 Part No. 200 81 097 Part No. 200 81 141 Part No. 200 81 090
Air cooling unit 115 V 230 V	Part No. 894 08 Part No. 855 31	Part No. 894 08 Part No. 855 31
Flange heater, DN 100 CF 115 V 230 V	Part No. 854 28 Part No. 854 27	Part No. 854 28 Part No. 854 27
Venting valve, DN 10 KF manually operated	Part No. 173 24	Part No. 173 24
Power failure venting valve, DN 10 KF 24 V DC 230 V, 50/60 Hz	Part No. 174 46 Part No. 174 26	Part No. 174 46 Part No. 174 26
Purge gas and venting valve, 230 V 0.2 mbar x l x s ⁻¹	Part No. 855 19	Part No. 855 19
Control unit for turbomolecular pump systems (see Section "Accessories")	upon request	upon request

PT 300 Dry Turbomolecular Pump System



The PT 300 Dry turbomolecular pump system is a fully assembled, ready-to-operate and mobile high vacuum pump system which is based on a column design.

Advantages to the User

- Absolutely oil-free
- Low ultimate pressure free of hydrocarbons (10^{-9} mbar/Torr)
- High effective pumping speed
- Compact, mobile unit
- Simple operation
- High level of reliability
- Maintenance-friendly design
- Installation in any orientation for SL 300
- Air cooling
- Installation of standard vacuum components in an open frame with installation column and castors
- Components such as the diaphragm backing pump and turbomolecular pump as well as venting or degassing are controlled via a single rotary switch
- Service-friendly assembly for maintenance without the need to disassemble backing or high vacuum pump
- Pump systems prepared for installation of larger backing pumps
- Additional mains sockets for accessories
- The pump systems are subjected to a full functional test and a leak test before delivery

The turbomolecular pump system consists of the following principal components:

- SL 300 wide range turbomolecular pump
- Two-stage, absolutely oil-free scroll pump SCROLLVAC SC 5D as the backing pump
- Switchbox for driving and interlocking of the two vacuum pumps
- Mobile base plate with column
- All required connection and sealing components are located within the pump system assembly

The pump systems are prepared for installation of further components:

- Vacuum gauges
- Flange heater
- Venting valve

Typical Applications

- Spectroscopy
- Valve manufacturing
- Beam guidance systems
- Micro balances
- Sputtering and evaporation systems
- Surface physics
- Laboratory pump systems

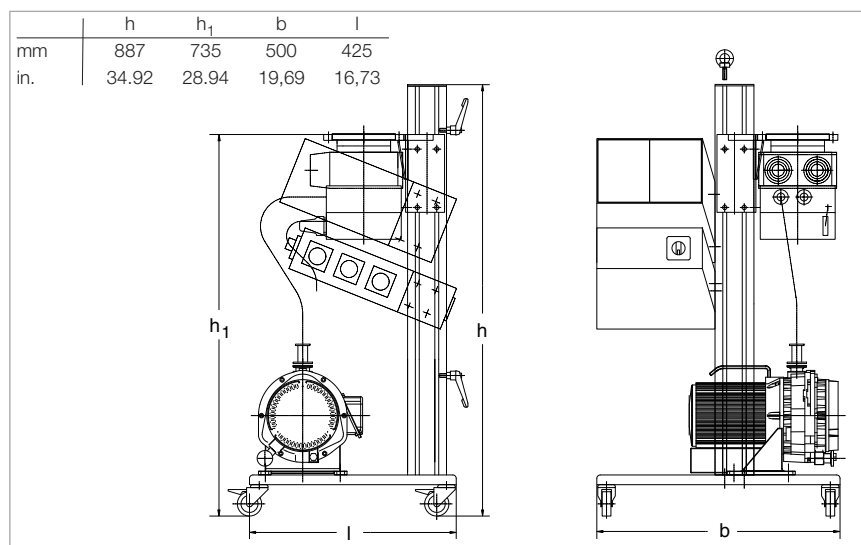

Dimensional drawing for the PT 300 Dry turbo molecular pump system

Technical Data

PT 300 Dry

Wide range turbomolecular pump		TURBOVAC SL 300	TURBOVAC SL 300
High vacuum connection	DN	100 ISO-K	100 CF
Pumping speed for N ₂	l x s ⁻¹	270	270
Scroll vacuum pump		SCROLLVAC SC 5 D	SCROLLVAC SC 5 D
Pumping speed, approx.	m ³ x h ⁻¹ (cfm)	5.4 (3.18)	5.4 (3.18)
Ultimate pressure, approx.	mbar (Torr)	< 0.05 (0.03)	< 0.05 (0.03)
Attainable ultimate pressure	mbar (Torr)	10 ⁻⁹ (0.75 x 10 ⁻⁹)	10 ⁻⁹ (0.75 x 10 ⁻⁹)
Main supply, 50/60 Hz	V	230 / 115	230 / 115
Rated power consumption, approx.	W	600	600
Dimensions (W x H x D)	mm (in.)	500 x 887 x 425 (19.68 x 34.92 x 16.73)	500 x 887 x 425 (19.68 x 34.92 x 16.73)
Weight, approx.	kg (lbs)	44 (97.13)	44 (97.13)

Ordering Information

PT 300 Dry

PT 300 Dry turbomolecular pump system			
DN 100 ISO-K 230 V, 50/60 Hz / 115 V, 60 Hz		Part No. 502 502	-
DN 100 CF 230 V, 50/60 Hz / 115 V, 60 Hz		-	Part No. 502 503
Mains adapter Schuko/US		Part No. 200 11 119	Part No. 200 11 119
Mains cord for junction box			
CH 230 V, 50/60 Hz		Part No. 200 81 099	Part No. 200 81 099
UK 230 V, 50/60 Hz		Part No. 200 81 097	Part No. 200 81 097
US/Japan 230 V, 50/60 Hz		Part No. 200 81 141	Part No. 200 81 141
US/Japan 115 V, 60 Hz		Part No. 200 81 090	Part No. 200 81 090
Power failure venting valve, DN 10 KF			
24 V DC		Part No. 800120V0021	Part No. 800120V0021
230 V, 50/60 Hz		Part No. 174 26	Part No. 174 26
Flange heater for flange DN 100 CF,			
115 V		-	Part No. 854 28
230 V		-	Part No. 854 27
Water cooling unit		Part No. 800135V0002	Part No. 800135V0002
24 V DC mains cord			
3 m (7.0 ft)		Part No. 800094V0300	Part No. 800094V0300
5 m (17.5 ft)		Part No. 800094V0500	Part No. 800094V0500
10 m (35.0 ft)		Part No. 800094V1000	Part No. 800094V1000
20 m (70.0 ft)		Part No. 800094V2000	Part No. 800094V2000
Copper sealing rings for CF flanges (set of 10 pieces)		-	Part No. 839 45
Control unit for turbomolecular pump systems (see Section "Accessories")		upon request	upon request

CS Calibration Systems

The requirements imposed on vacuum engineering with regard to accuracy of the measurements, reproducibility and unambiguity of the determined vacuum pressures have increased significantly over the last years.

Routine calibrations of vacuum gauges are an important component of quality assurance schemes. The calibration systems from Oerlikon Leybold Vacuum put the customer in a position to check and recalibrate on his own the specified and necessary accuracy of his vacuum gauges.

Calibration systems are available for this purpose which cover a calibration range from 1000 mbar to 1×10^{-7} mbar (750 to 0.75×10^{-7} Torr).

Each system is equipped with several certified reference pressure sensors (transmitter standards), which each cover a part of the specified range of calibration pressures. In the pump system, turbomolecular pumps with TRIVAC rotary vane or DIVAC diaphragm pumps are used. A variable leak valve is used to admit the gas into the calibration chamber. In the case of the calibration system CS7, the gas inlet line is, moreover, equipped with it's own pump system.

The CS7 is equipped with a heater for the vacuum chamber, for the purpose of attaining lower chamber pressures more rapidly. The temperature of the heating collars can be controlled whereby the maximum degassing temperature will depend on the components installed (flanges, pressure sensors, valves).

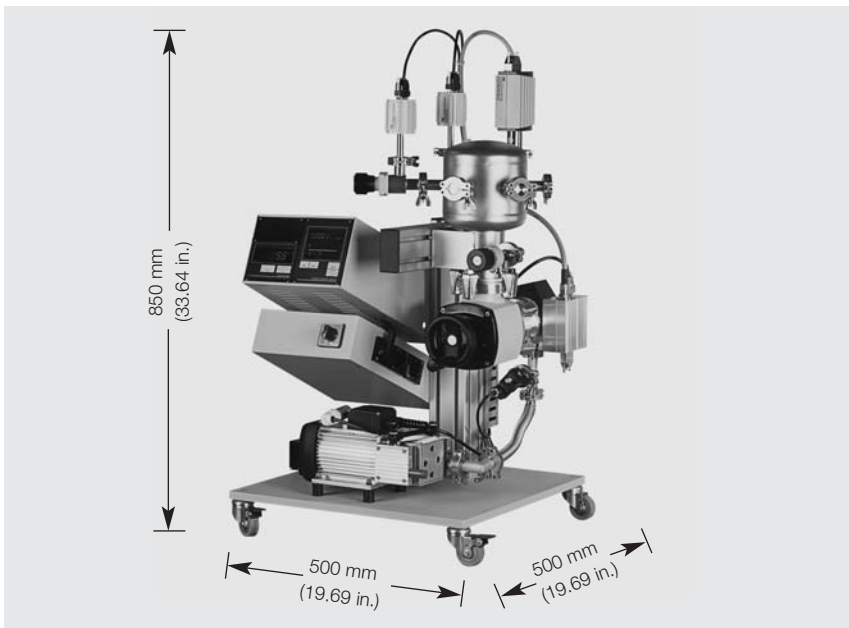

CS3 calibration system

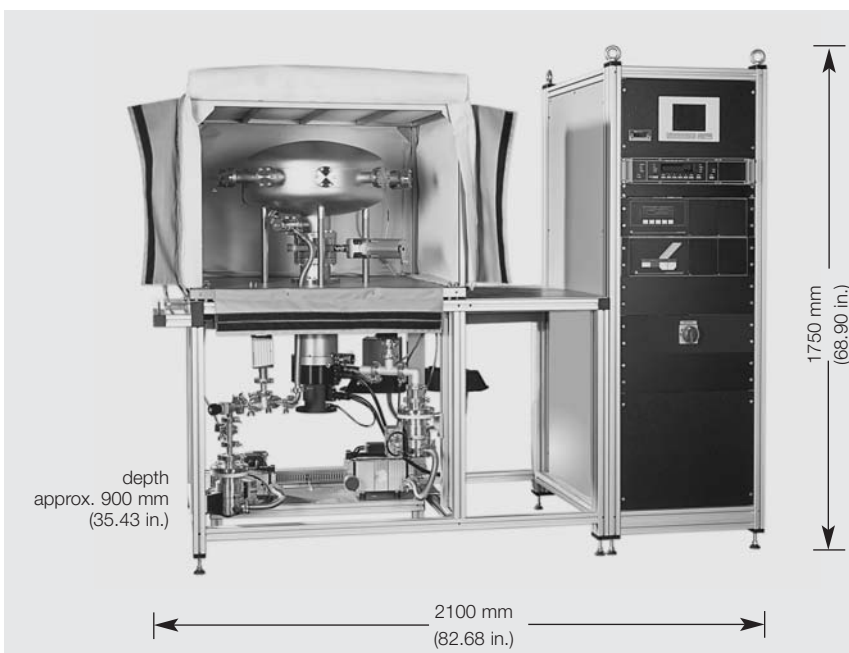

CS7 calibration system

Advantages to the User

- Vacuum gauges and measurement systems of any make may be calibrated
- Designed in accordance with DIN 28 418/ISO/DIS 3567
- Transfer standards with PTB-, DKD- or factory certificate
- Easier DIN/ISO 9000 approval
- Reliable and reproducible measurements
- Quick start-up
- Measurement system free of hydrocarbons when using dry compressing vacuum pumps
- Simple operation
- CE approval

Technical Data

Calibration System

		CS3	CS7
Calibration range	mbar (Torr)	1000 to 1×10^{-3} (750 to 0.75×10^{-3})	1000 to 1×10^{-7} (750 to 0.75×10^{-7})
Pressure measurement range	mbar (Torr)	1000 to 2×10^{-6} (750 to 1.5×10^{-6})	1000 to 2×10^{-9} (750 to 1.5×10^{-9})
Vacuum chamber connections (in brackets: quantity available on the side of the customer's system)		5 (3) x DN 16 KF 1 (0) x DN 25 KF	6 (3) x DN 16 CF 6 (4) x DN 40 CF
Admitting gas		via variable leak valve	via variable leak valve
Extra pump system for admitting gas		no	yes
Heater for the vacuum chamber		no	yes

Application examples:

Which pressure sensors may be calibrated with which system?

Typ of Sensor

Calibration System

	CS3	CS7
Diaphragm sensors		
BOURDONVAC	■	■
Capsule vacuum gauges	■	■
DIAVAC DV 1000	■	■
DI 200, DI 2000	■	■
CTR 90, CTR 91, CTR 100 (1000 - 1 Torr full scale)	■	■
CTR 91 (0.1 Torr full scale)		■
THERMOVAC sensors		
TR 301, TR 306	■	■
TR 211, TR 216, TTR 211, TTR 216, TTR 90, TTR 91, TTR 96, TTR 100	■	■
VISCOVAC sensor (spinning rotor viscosity gauge)		
VK 201		■
PENNINGVAC sensors		
PR 25, PR 26, PR 27, PR 35, PR 36, PR 37, PTR 90, PTR 225		■
IONIVAC sensors		
ITR 90, ITR 100, ITR 200		■
IE 414, IE 514		■

Ordering Information

Calibration System

	CS3	CS7
Ordering information and options	upon request	upon request

Accessories

Control Unit for Turbomolecular Pump Systems



Control unit for turbomolecular pump systems

The control unit is suited for operation in connection with turbomolecular pump systems PT 50, PT 80 Dry, PT 151/361, PT 151/361 Dry, PT 300 Dry; as well as custom pump systems.

The graphic monochrome display with its blue LED backlight offers excellent visibility also under difficult conditions.



Control unit installed in the PT 80 Dry pump system

Advantages to the User

- Either automatic/manual operation
- Pressure readout for forevacuum and high vacuum is possible
- Selectable pressure units: mbar, torr, Pa
- Graphic display of the pressure curve
- Connectable high vacuum sensors: PTR and ITR
- Setting up the cut-in pressure for the turbomolecular pump is possible
- Venting of the pump system through a delayed venting function
- Memory card for recording data is connectable
- Data recording through a PC is possible
- Menu navigation in different languages

Ordering Information

Control Unit for Turbomolecular Pump Systems

Control unit for turbomolecular pump systems

upon request

Adsorption Traps with Aluminium Oxide Insert

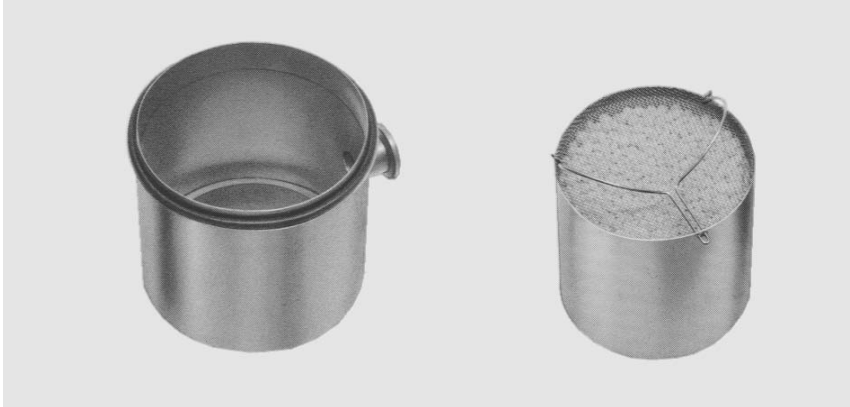

Adsorption trap (left) and insert (right)

Adsorption traps are installed in all those cases where an oil-free vacuum is to be produced with oil-sealed vacuum pumps.

Advantages to the User

- Backstreaming of oil is reduced by 99%
- Longer service life
- High conductance
- Filling can be easily exchanged
- Improvement in the ultimate pressure attained by backing pumps by one order of magnitude
- Stainless steel housing and insert
- NBR seal

Typical Applications

- Product of an oil-free vacuum

Supplied Equipment

- Complete with insert
- Without adsorbent

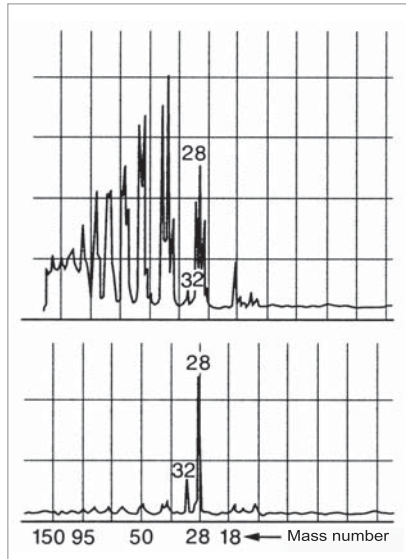

Residual gas spectrum; top ahead of a rotary vacuum pump, bottom ahead of a rotary vacuum pump with adsorption trap

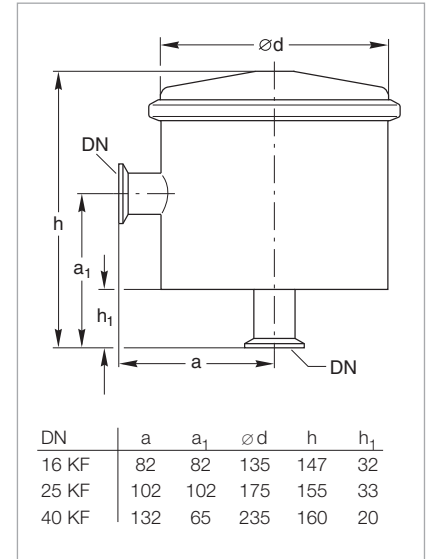

Dimensional drawing for the adsorption traps

Technical Data

		Adsorption Trap		
		16 KF	25 KF	40 KF
Conductance at 10 ⁻² mbar (Torr)	l x s (l x sec)	4	6	12
Service live with Al oxide	Months	3	3	3
Al oxide filling	l (qts)	0.5 (0.53)	1.0 (1.06)	2.0 (2.1)
Weight, approx.	kg (lbs)	1.3 (2.9)	1.3 (2.9)	4.0 (8.8)

Ordering Information

		Adsorption Trap		
		16 KF	25 KF	40 KF
Adsorption trap		Part No. 854 14	Part No. 854 15	Part No. 854 16
Activated aluminum oxide in tin 1.6 l (approx. 1.2 kg (2.65 lbs))		Part No. 854 10	Part No. 854 10	Part No. 854 10

Only available for purchase in North and South America

PT-FLEX Dry Turbomolecular Pump System



PT-FLEX pumping systems provide unique flexibility, allowing the user to define the optimum combination of performance and price.

PT-FLEX pump systems are offered with three sizes Compound Turbo-molecular pumps, three sizes dry Scroll backing pumps, a basic or full-featured system controller and the ability to incorporate and control multiple valves, vacuum gauges, flange heaters and other peripheral equipment.

PT-FLEX systems can be specially configured with classic turbo pumps and rotary vane forevacuum pumps. Please consult Oerlikon Leybold Vacuum for details.

Advantages to the User

- Oil free high vacuum
- Compact, mobile
- Air cooled
- Adjustable height
- Fully assembled and tested

Configuration and Capabilities

- Three sizes turbo pump
- Three sizes dry scroll forevacuum pump
- Manual or powered height adjustment
- Ability to power and control multiple peripheral devices (sold separately)
- Basic or full-featured TSC system controller
- Allows mounting of one or two rack gauge controllers

PT-FLEX with BASIC Controller

- Mains ON/OFF
- Mains switch activated 115 V AC output for use with vent valve or gauge controller
- Start / Stop switch for both pumps
- Manual control and power for
 - Pumps
 - Vent valves
 - Vacuum isolation valves
 - Flange heater
- Provides additional 115 V AC and 24 V DC outputs to power additional peripheral devices
- Vacuum Ion Gauge degas function for gauge model ITR 90
- Turbo operation indicator

PT-FLEX with TSC Controller

(see separate catalog page for in-depth description of features and capabilities)

- One button auto system control
- Monitors and displays all turbo pump operating and diagnostic parameters
- Acts as display for up to 3 "smart" vacuum gauge sensors
- All features of PT-Flex BASIC controller
- Additional power and control capabilities for peripheral equipment

Technical Data

PT-FLEX

Turbomolecular pump High vacuum connection	DN	TURBOVAC SL 80 63 ISO-K 63 CF	TURBOVAC SL 300 100 ISO-K 100 CF
Backing pumps		SCROLLVAC SC 5 D	SCROLLVAC SC 5 D SCROLLVAC SC 15 D
Cooling		Air	Air (water option)
Max. current requirements (dependent on forepump)	V AC Phase Hz A	115 1 50/60 15	115 1 50/60 15
Controller		<p>TSC Turbo System Controller AUTO operation with gauge selection or Manual TW monitoring status Gauge sensor display with smart gauge selection</p> <p>Accessory Control Inlet, foreline and roughing valve Vent/purge valve Flange heater (CF flange only) Ion sensor degas</p> <p>Basic System Controller Manual Start/Stop operation</p> <p>Accessory Control Vacuum valve Vent valve Flange heater (CF flange only) Ion sensor degas Column height adjustment (option)</p>	

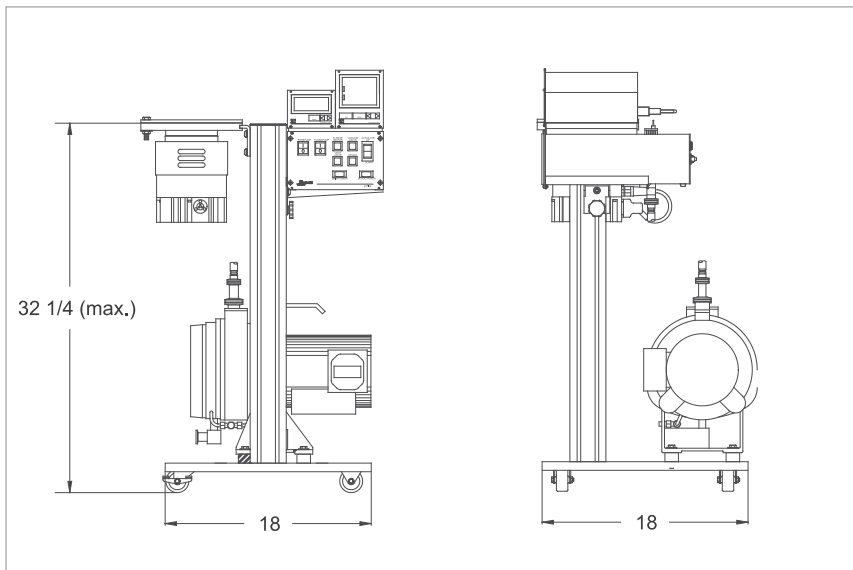

Dimensional drawing for the PT-Flex (manual post)

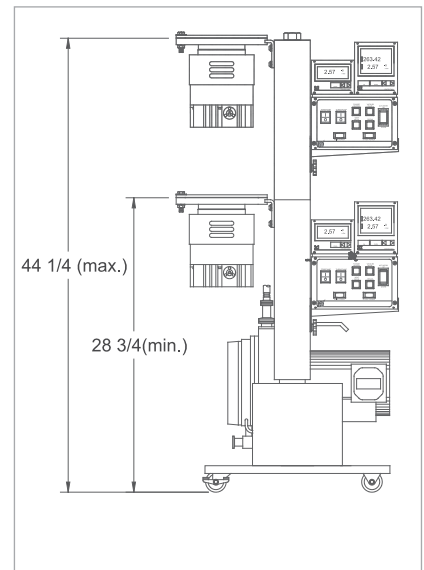

Dimensional drawing (front view) for the PT-Flex (powered support)

Ordering Information

PT-Flex

Base number

Manual controls

- manual height adjustment
- electric height adjustment

Automated controls

- manual height adjustment

Turbomolecular pump

- SL 80 with DN 63 ISO-K inlet
- SL 80 with DN 63 CF inlet
- SL 300 with DN 100 ISO-K inlet
- SL 300 with DN 100 CF inlet
- TW 250S with DN 100 ISO-K inlet
- TW 250S with DN 100 CF inlet

Dry scroll pump

- Not used
- SC 5 D
- Reserved for future use
- SC 15 D (SL 300 only)

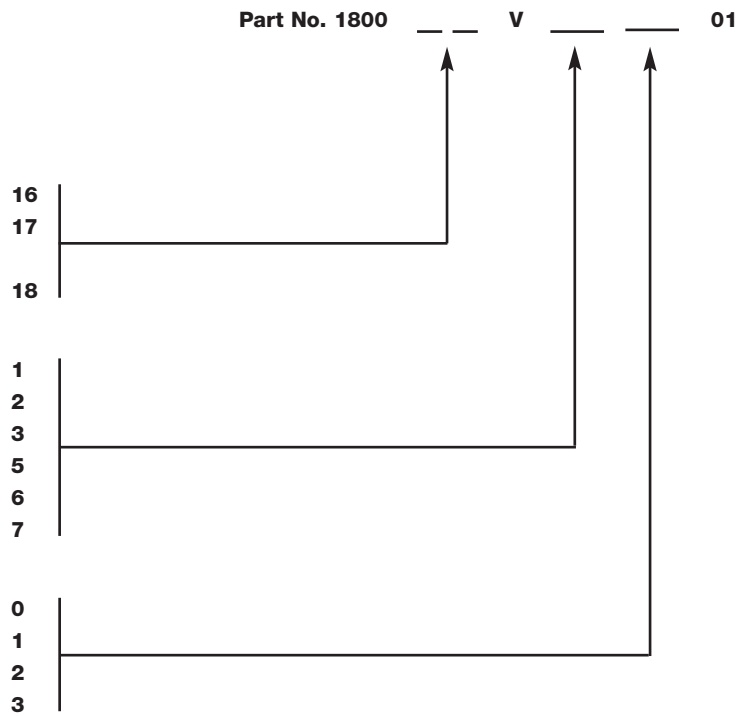

Only available for purchase in North and South America

TSC-TurboSystem Controller

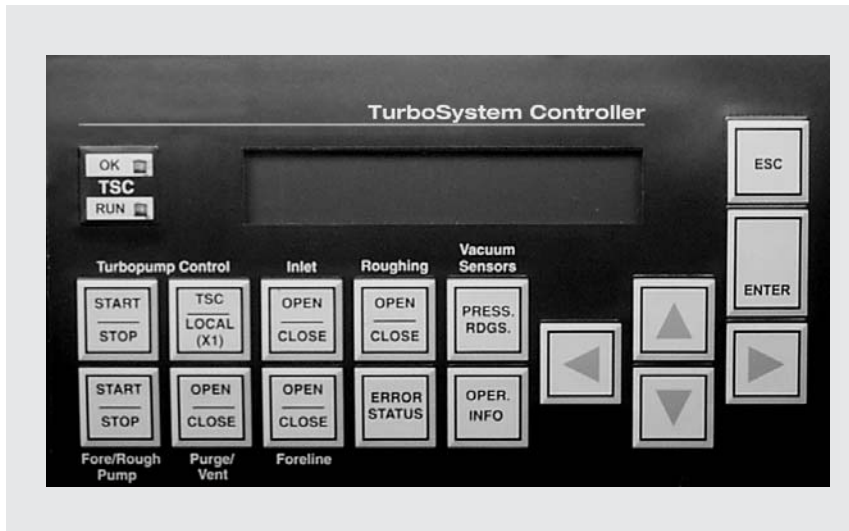

The TSC controller will:

- Display all relevant turbo information:
 - Connected pump model
 - Rotation frequency (Hz)
 - Rotation speed (rpm)
 - Bearing temperature (°C)
 - Motor current (Amps)
 - Motor temperature (°C)
 - Supply voltage (V)
 - Heatsink temperature (°C)
 - Cumulative operating time (hours)
- Power the turbomolecular pump
- Power the fore/rough pump (up to TRIVAC D 16 B or ECODRY M 15, 115 V single phase)
- Power and display up to three of any manufacturer's smart gauges (must have 0 - 10 V or 4 - 20 mA output capability)
- Provide degas capability for a hot-cathode ion gauge sensor
- Power up to three system valves (electropneumatic with 24 V DC coils; electromagnetic valves on request) – typically an inlet valve, foreline valve and roughing valve
- Power a turbomolecular pump vent or purge/vent valve
- Power an inlet flange heater (CF flanged pumps only)
- Control the turbomolecular pump, fore/rough pump and all valves

Technical Data

TSC - TurboSystem Controller

For operating turbomolecular pump		
TSC-S TurboSystem Controller	TURBOVAC TW 300 / TW 70 H	-
TSC-L TurboSystem Controller	-	TURBOVAC TW 700

Ordering Information

TSC - TurboSystem Controller

TSC - TurboSystem Controller		
115 V, RS 485 C		
TSC-S	Part No. 899 287	-
TSC-L	-	Part No. 899 288
115 V, RS 232 C		
TSC-S	Part No. 899 289	-
TSC-L	-	Part No. 899 290
Venting valve		
24 V DC, normally open	Part No. 899 813	Part No. 899 813
24 V DC, normally closed	Part No. 899 814	Part No. 899 814

Note:

All controllers include:

15 ft. (5 m) long cables between TSC controller and turbomolecular pump (power & communication)

6 ft. (2 m) power cord

Mating connectors for all accessorizing outlets

Operating manual, electrical schematic, and spare parts list

Only available for purchase in North and South America

TPC-TurboPump Controller

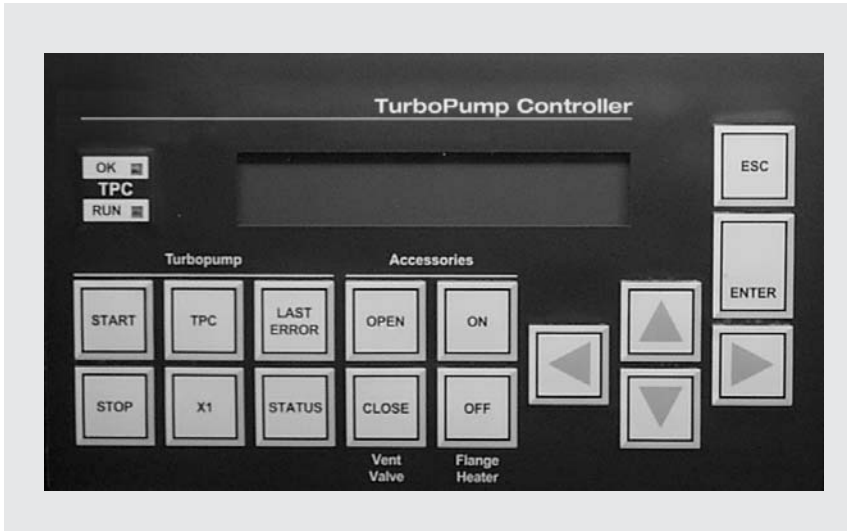

The TPC controller will:

- Display all relevant turbo information:
 - Connected pump model
 - Rotation frequency (Hz)
 - Rotation speed (rpm)
 - Bearing temperature (°C)
 - Motor current (Amps)
 - Motor temperature (°C)
 - Supply voltage (V)
 - Heatsink temperature (°C)
 - Cumulative operating time (hours)
- Power the turbomolecular pump
- Power a turbomolecular pump vent or purge/vent valve
- Power an inlet flange heater (CF flanged pumps only)
- Control the turbomolecular pump, flange heater and purge/vent valve

Technical Data

TPC - TurboPump Controller

For operating turbomolecular pump			
TPC-S TurboPump Controller	TURBOVAC TW 300 TURBOVAC TW 70 H	-	-
TPC-L TurboPump Controller	-	TURBOVAC TW 700	-
TPC-1600 TurboPump Controller	-	-	TURBOVAC T 1600 TURBOVAC TW 1600

Ordering Information

TPC - TurboPump Controller

TPC - TurboPump Controller			
115 V, RS 485 C			
TPC-S	Part No. 899 281	-	-
TPC-L	-	Part No. 899 282	-
115 V, RS 232 C			
TPC-S	Part No. 899 283	-	-
TPC-L	-	Part No. 899 284	-
115 V, RS 485 C			
TPC-1600	-	-	Part No. 899 285
115 V, RS 232 C			
TPC-1600	-	-	Part No. 899 286
230 V, RS 485 C			
TPC-1600	-	-	Part No. 899 295
230 V, RS 232 C			
TPC-1600	-	-	Part No. 899 296
Venting valve			
24 V DC, normally open	Part No. 899 813	Part No. 899 813	Part No. 899 813
24 V DC, normally closed	Part No. 899 814	Part No. 899 814	Part No. 899 813

Note:

All controllers include:

15 ft. (5 m) long cables between TSC controller and turbomolecular pump (power & communication)

6 ft. (2 m) power cord

Mating connectors for all accessory, outlets

Operating manual, electrical schematic, and spare parts list

Sales and Service

Germany

Oerlikon
Leybold Vacuum GmbH
Bonner Strasse 498
D-50968 Cologne
Phone: +49-(0)221-347 1234
Fax: +49-(0)221-347 1245
sales.vacuum@oerlikon.com
www.oerlikon.com

Oerlikon
Leybold Vacuum GmbH
Sales Area North/Northeast
Branch Office Berlin
Industriestrasse 10b
D-12099 Berlin
Phone: +49-(0)30-435 609 0
Fax: +49-(0)30-435 609 10
sales.vacuum.bn@oerlikon.com

Oerlikon
Leybold Vacuum GmbH
Sales Area South/Southwest
Branch Office Munich
Karl-Hammerschmidt-Strasse 34
D-85609 Aschheim-Dornach
Phone: +49-(0)89-357 33 9-10
Fax: +49-(0)89-357 33 9-33
sales.vacuum.mn@oerlikon.com
service.vacuum.mn@oerlikon.com

Oerlikon
Leybold Vacuum GmbH
Sales Area West & Benelux
Branch Office Cologne
Bonner Strasse 498
D-50968 Cologne
Phone: +49-(0)221-347 1270
Fax: +49-(0)221-347 1291
sales.vacuum.kn@oerlikon.com

Oerlikon
Leybold Vacuum GmbH
Service Competence Center
Emil-Hoffmann-Strasse 43
D-50996 Cologne-Suerth
Phone: +49-(0)221-347 1439
Fax: +49-(0)221-347 1945
service.vacuum.kn@oerlikon.com

Oerlikon
Leybold Vacuum GmbH
Mobil Customer Service
Emil-Hoffmann-Strasse 43
D-50996 Cologne-Suerth
Phone: +49-(0)221-347 1765
Fax: +49-(0)221-347 1944
service.vacuum.kn@oerlikon.com

Oerlikon
Leybold Vacuum
Dresden GmbH
Service Competence Center
Zur Wetterwarte 50, Haus 304
D-01109 Dresden
Service:
Phone: +49-(0)351-88 55 00
Fax: +49-(0)351-88 55 041
info.vacuum.dr@oerlikon.com

Europe

Belgium
Oerlikon
Leybold Vacuum Nederland B.V.
Belgisch bijkantoor
Leuvensesteenweg 542-9A
B-1930 Zaventem
Sales:
Phone: +32-2-711 00 83
Fax: +32-2-720 83 38
sales.vacuum.zv@oerlikon.com
Service:
Phone: +32-2-711 00 82
Fax: +32-2-720 83 38
service.vacuum.zv@oerlikon.com

France
Oerlikon
Leybold Vacuum France S.A.
7, Avenue du Québec
Z.A. de Courtaboeuf 1 - B.P. 42
F-91942 Courtaboeuf Cedex
Sales and Service:
Phone: +33-1-69 82 48 00
Fax: +33-1-69 07 57 38
info.vacuum.ctb@oerlikon.com
sales.vacuum.ctb@oerlikon.com

Oerlikon
Leybold Vacuum France S.A.
Valence Factory
640, Rue A. Bergès
B.P. 107 640
F-26501 Bourg-lès-Valence Cedex
Service:
Phone: +33-4-75 82 33 00
Fax: +33-4-75 82 92 69
marketing.vacuum.vc@oerlikon.com

Great Britain
Oerlikon
Leybold Vacuum UK LTD.
Silverglade Business Park
Leatherhead Road Unit 2
KT9 2QL Chessington, Surrey
(London)
Sales:
Phone: +44-13-7273 7300
Fax: +44-13-7273 7301
sales.vacuum.ln@oerlikon.com
Service:
Phone: +44-20-8971 7030
Fax: +44-20-8971 7003
service.vacuum.ln@oerlikon.com

Italy
Oerlikon
Leybold Vacuum Italia S.r.l.
Via Trasimeno 8
I-20128 Milano
Sales:
Phone: +39-02-27 22 31
Fax: +39-02-27 20 96 41
sales.vacuum.mi@oerlikon.com
Service:
Phone: +39-02-27 22 31
Fax: +39-02-27 22 32 17
service.vacuum.mi@oerlikon.com

Netherlands
Oerlikon
Leybold Vacuum Nederland B.V.
Proostwetering 24N
NL-3543 AE Utrecht
Sales and Service:
Phone: +31-(30) 242 6330
Fax: +31-(30) 242 6331
sales.vacuum.ut@oerlikon.com
service.vacuum.ut@oerlikon.com

Spain
Oerlikon
Leybold Vacuum Spain, S.A.
C/ Huelva 7
E-08940 Cornellà de Llobregat
(Barcelona)
Sales:
Phone: +34-93-666 43 11
Fax: +34-93-666 43 70
sales.vacuum.ba@oerlikon.com
Service:
Phone: +34-93-666 46 16
Fax: +34-93-685 43 70
service.vacuum.ba@oerlikon.com

Sweden
Oerlikon
Leybold Vacuum Scandinavia AB
Box 9084
SE-40092 Göteborg
Sales and Service:
Phone: +46-31-68 84 70
Fax: +46-31-68 39 39
info.vacuum.gt@oerlikon.com
sales.vacuum.gt@oerlikon.com
Visiting/delivery address:
Datavägen 57B
SE-43632 Askim

Switzerland
Oerlikon
Leybold Vacuum Schweiz AG
Leutschenbachstrasse 55
CH-8050 Zürich
Sales:
Phone: +41-44-308 40 50
Fax: +41-44-302 43 73
sales.vacuum.zh@oerlikon.com
Service:
Phone: +41-44-308 40 62
Fax: +41-44-308 40 60
service.vacuum.zh@oerlikon.com

America

USA
Oerlikon
Leybold Vacuum USA Inc.
5700 Mellon Road
USA-Export, PA 15632
Phone: +1-724-327-5700
Fax: +1-724-325-3577
info.vacuum.ex@oerlikon.com
Sales:
Eastern & Central time zones
Phone: +1-724-327-5700
Fax: +1-724-333-1217
Pacific, Mountain, Alaskan &
Hawaiian time zones
Phone: +1-408-436-2828
Fax: +1-408-436-2849
Service:
Phone: +1-724-327-5700
Fax: +1-724-325-3577

Latin America
Oerlikon
Leybold Vacuum USA Inc.
Brazilian Office
Av. Dória 360 cj. 12 Campo Belo
04635-070 São Paulo SP BRAZIL
Sales:
Phone: +55 11-3554 3117
Fax: +55 11-3554 3117
nelson.batistucci@oerlikon.com

Oerlikon
Leybold Vacuum GmbH
Bonner Strasse 498
D-50968 Cologne
Phone: +49-(0)221-347 0
Fax: +49-(0)221-347 1250
info.vacuum@oerlikon.com

Asia

P.R. China
Oerlikon
Leybold Vacuum (Tianjin)
International Trade Co. Ltd.
Beichen Economic
Development Area (BEDA),
No.8 Western Shuangchen Road
Tianjin 300400
China
Sales and Service:
Phone: +86-22-2697 0808
Fax: +86-22-2697 4061
Fax: +86-22-2697 2017
info.vacuum.tj@oerlikon.com
sales.vacuum.tj@oerlikon.com
service.vacuum.tj@oerlikon.com

Oerlikon
Leybold Vacuum
(Tianjin) Co. Ltd.
Beichen Economic
Development Area (BEDA),
No.8 Western Shuangchen Road
Tianjin 300400
China
Sales and Service:
Phone: +86-22-2697 0808
Fax: +86-22-2697 4061
info.vacuum.tj@oerlikon.com
sales.vacuum.tj@oerlikon.com
service.vacuum.tj@oerlikon.com

Oerlikon
Leybold Vacuum (Tianjin)
International Trade Co. Ltd.
Shanghai Branch:
No.33
76 Fu Te Dong San Road
Waigaoqiao Free Trade Zone
Shanghai 200131
China
Sales and Service:
Phone: +86-21-5064-4666
Fax: +86-21-5064-4668
info.vacuum.sh@oerlikon.com
sales.vacuum.sh@oerlikon.com
service.vacuum.sh@oerlikon.com

Oerlikon
Leybold Vacuum (Tianjin)
International Trade Co. Ltd.
Guangzhou Office and
Service Center
1st F, Main Building
Science City Plaza,
No.111 Science Revenue,
Guangzhou Science City
(GZSC) 510663, Guangzhou,
China
Sales:
Phone: +86-20-223 23 980
Fax: +86-20-223 23 990
info.vacuum.gz@oerlikon.com
sales.vacuum.gz@oerlikon.com
service.vacuum.gz@oerlikon.com

Oerlikon
Leybold Vacuum (Tianjin)
International Trade Co. Ltd.
Beijing Branch:
1-908, Beijing Landmark Towers
8 North Dongsanhuan Road
Beijing 100004
China
Sales:
Phone: +86-10-6590-7622
Fax: +86-10-6590-7607
sales.vacuum.bj@oerlikon.com
service.vacuum.bj@oerlikon.com

India
Oerlikon
Leybold Vacuum India Pvt Ltd.
EL 22, J-Block
MIDC Bhosari
Pune 411026
India
Sales and Service:
Phone: +91-20-3061 6000
Fax: +91-20-2712 1571
sales.vacuum.pu@oerlikon.com
service.vacuum.pu@oerlikon.com

Japan
Oerlikon
Leybold Vacuum
Japan Co., Ltd.
Headquarter
23-3, Shin-Yokohama
3-chome
Tobu A.K. Bldg. 4th Floor
Kohoku-ku
Yokohama-shi 222-0033
Sales:
Phone: +81-45-471-3330
Fax: +81-45-471-3323
info.vacuum.yh@oerlikon.com
sales.vacuum.yh@oerlikon.com

Oerlikon
Leybold Vacuum
Japan Co., Ltd.
Osaka Sales Office
3F, Shin-Osaka Terasaki
No.3 Bldg.
1-5-28 Nishi-Miyahara
Yodogawa-ku, Osaka-shi
Osaka 532-0004
Phone: +81-6-6399-6271
Fax: +81-6-6399-6273
info.vacuum.os@oerlikon.com
sales.vacuum.os@oerlikon.com

Oerlikon
Leybold Vacuum
Japan Co., Ltd.
Tsukuba Technical Service Center
Kogyo Danchi
21, Kasuminosato,
Ami-machi, Inashiki-gun
Ibaraki-ken, 300-0315
Service:
Phone: +81-298 89 2841
Fax: +81-298 89 2838
info.vacuum.iik@oerlikon.com
sales.vacuum.iik@oerlikon.com

South Korea
Oerlikon
Leybold Vacuum Korea Ltd.
3F, Jellzone 2 Tower
Jeongja-dong 159-4
Bundang-gu Sungnam-si
Gyeonggi-do
Bundang 463-384, Korea
Sales:
Phone: +82-31 785 1367
Fax: +82-31 785 1359
sales.vacuum.bd@oerlikon.com

Service:
623-7, Upsung-Dong
Cheonan-Si
Chungcheongnam-Do
Korea 330-290
Phone: +82-41 589 3035
Fax: +82-41 588 0166
service.vacuum.cn@oerlikon.com

Singapore
Oerlikon
Leybold Vacuum
Singapore Pte Ltd.
1 Science Park Road
Singapore Science Park 2
#02-12, Capricorn Building
Singapore 117528
Sales and Service:
Phone: +65-6303 7000
Fax: +65-6773 0039
sales.vacuum.sg@oerlikon.com
service.vacuum.sg@oerlikon.com

Taiwan
Oerlikon
Leybold Vacuum Taiwan Ltd.
No 416-1, Sec. 3
Chungshin Road., Chutung
Hsinchu County 310
Taiwan, R.O.C.
Sales and Service:
Phone: +886-3-500 1688
Fax: +886-3-583 3999
sales.vacuum.hc@oerlikon.com
service.vacuum.hc@oerlikon.com

oerlikon
leybold vacuum
www.oerlikon.com/leyboldvacuum