

NOTICE: This document contains references to Varian. Please note that Varian, Inc. is now part of Agilent Technologies. For more information, go to [www.agilent.com/chem](http://www.agilent.com/chem).



# Ion Pumps

Features and Benefits - Pumps  
2-3

Features and Benefits - Controllers  
4-5

Features and Benefits - SEM Pumps  
6-7

Typical Applications  
8-11

Pump Models  
12-38

Technical Notes  
39-49

Service and Support Plan  
50-51

VARIAN V.FLLI VARIAN 54

LEINI (TO) MADE IN ITALY CE  
EX9191440 #203721



# Ion Pump Features and Benefits

## Ion Pump Evolution

- Since the late 1950's, when the ion pump was invented at Varian, many changes and technical improvements have taken place. Virtually all of the major innovations have come from Varian, from the first Diode Vaclon pump to the Triode, then to the StarCell® series pumps, and the Vaclon *Plus*.



## Vaclon *Plus*

- Vaclon *Plus* is a complete family of ion pumps, controllers, options, and accessories, designed to provide solutions to every application. Parameters such as operating pressure, the gas mixture to be pumped, the starting pressure, etc. can vary so dramatically that Varian decided to develop dedicated ion pump solutions (including controllers and all other accessories) for different applications.
- The Vaclon *Plus* family includes Diode, Noble Diode, and StarCell® pump versions that allow Varian to provide the best technology for each field of application. The family is complemented by the MiniVac and Dual Ion Pump controllers, that provide different power levels and interface capabilities.

## Titanium Sublimation Combination Pumps (TSP)

- The titanium sublimation creates extra high getterable gas pumping speed while the ion pumping mechanisms handle the non-getterable gases such as argon and methane. The combination pump includes the cylindrical cryopanel and TSP source mounted to the extra port. Customized pump configurations are also available.



### Element Cells and Insulators

- Cells' sizes and geometries are optimized in order to:
  - maximize the discharge intensity
  - maximize the pumping speed.
- The special design of the ceramic insulators allows:
  - no buildup of sputtered conductive coating
  - longer pump life.



### Application Specific Solutions for SEM:

a complete line of ion getter pumps dedicated to Electron Microscopy.



### Vacuum Processing

In order to ensure cleanliness, all pumps are:

- Factory processed at high temperature (400°) in ultra-high vacuum for a thorough outgassing of the body and all internal components.
- Shipped under vacuum, and an RGA spectrum can be provided with each pump.



### Wide Pumping Speed Range

- Miniature/Appendage pumps from 0.2 to 8 l/s.
- Small/Medium pumps from 20 to 75 l/s.
- Large size pumps from 150 to 1000 l/s.
- TSP/Combi pumps.
- Custom solutions available.

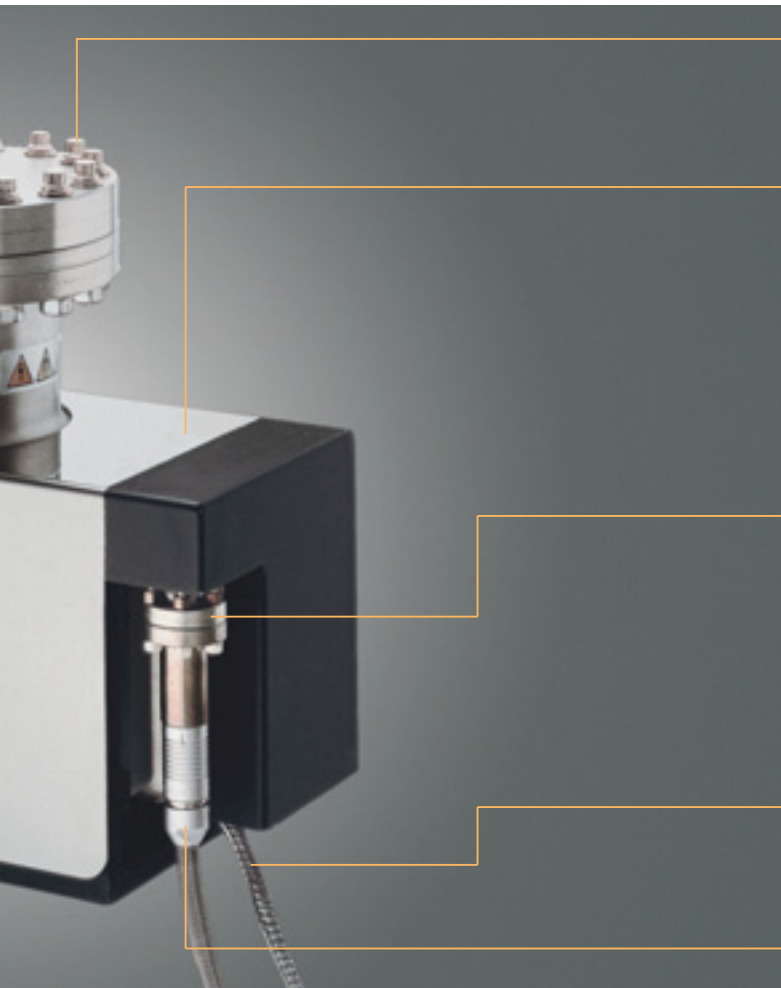

### Custom Design

The pump body can be configured to meet optional requirements including:

- Cryopanel and TSP side or bottom mounted.
- NEG modules.
- Integral heaters.
- Additional roughing ports.



### Feedthroughs

- Eliminate corrosion.
- Implement the "High Voltage Cable Interlock".
- Provide an easy connection.
- Prevent unintentional extraction.
- Minimize overall dimensions.



### Heaters

- The pump can be supplied with heaters designed to perform the pump baking.
- Minimize operational costs.



### Pumping Elements

Three different types of pumping elements are available to cover all possible gas mixtures and optimize the application specific performances:

- Diode.
- Noble Diode.
- The unique StarCell®.



### Cables

- The new cables have an "HV Safety Interlock" that prevents any chance of electrical shock.
- If the cable is disconnected from the pump, the voltage is automatically cut off.
- Available in different lengths.

# Ion Pump Controller Features and Benefits

## More Choice and Flexibility

- The Vaclon *Plus* pump family is complemented by the MiniVac and Dual Ion Pump controllers, that provide different power levels and interface capabilities.
- A dedicated TSP controller is also available.
- The new series of IPCU controller units completes Varian's offer (see next pages).
- The existing range of ion pump controllers offers more choice and flexibility than ever before. With the latest in design features, they are simple and easy to operate. You can select just the right controller to fit your specific application, whether it is the low-cost MiniVac, or the Dual.
- The Dual controller is designed to power any size and type of ion pump, featuring single- or dual-voltage outputs for independent and simultaneous control of two ion pumps.



### "Dual" Controller

- A very compact instrument, only 1/2 rack across.
- Can drive 2 independent pumps.
- Can drive 2 UHV gauges simultaneously.



### Application Specific Solutions for SEM:

a line of ion pump controllers dedicated to Electron Microscopy.

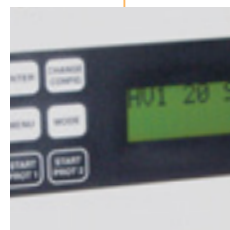

### Pre-programmed Parameters

- The Controller reads the Ion Pump Parameters V, A and P from a selection menu, for any Vaclon pump or fully programmable spare pump.

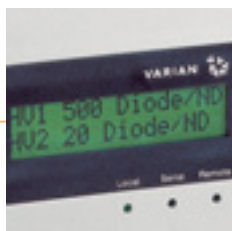

**Display**

- 10 nA current resolution guarantees an accurate reading.

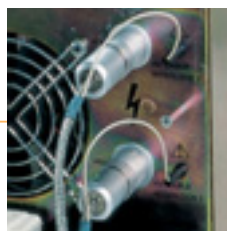

**Cables**

- The new cables have an "HV Safety Interlock" that prevents any chance of electrical shock since the voltage is automatically cut off as soon as the cable is disconnected from the pump.



**I/O Pinout**

- External interlock capability allows easy setup of safety precautions for the ion pump operation.

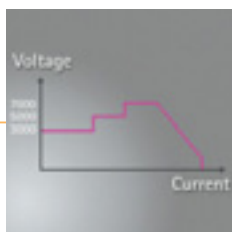

**Step Voltage**

The applied High Voltage is automatically optimized in order to:

- Improve pumping speed performance.
- Provide a more accurate pressure reading.



**Serial Connector Interface**

- Allows any standard communication (RS232, RS485, RS422) command and signals.

# SEM Ion Pump and Controller Features and Benefits

## The Varian Advantage: Dedicated Solutions for SEM Applications

- Varian is the only manufacturer to offer specially designed SEM ion pumps. These pumps are ideal for the high vacuum guns where stable vacuum and low leakage current is required to control and preserve the charged particle filament.
- The key to this superior performance is Varian's patented anode design which uses contoured cells and simplified electrical elements. This insures stable current readings and lower particle generation.
- When combining the SEM ion pump on the gun with a StarCell ion pump on the lower column, Varian ion pumps can offer a powerful combination optimised for modern E-beam columns.

SEM Ion Pumps are available on request; please ask Varian for technical details.



Supply Chain Partner  
Carl Zeiss SMT AG

Carl Zeiss SMT, global leader in light, electron and ion-optical technologies for industry and R&D, has designated Varian Vacuum Technologies as a Carl Zeiss SMT Supply Chain Partner.

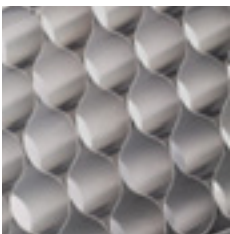

### Innovative SEM Anode Geometry

- Better current stability.
- Lowest leakage current in the industry (< 10 nA).
- Double Shielded Ceramics.
- Longer pump life.
- Longer pressure stability.
- Maximum uptime.



### Very Compact Design

- Improved design for:
- Lighter pump weight.
  - Fast magnets replacement.
  - Easy maintenance.

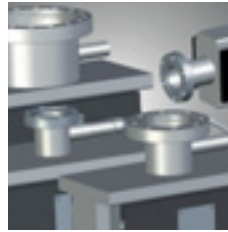

### Wide, Dedicated Range

- A complete range of SEM ion pumps from 10 to 75 l/s, tailored to your specific vacuum needs.
- Small footprint for easier system integration.

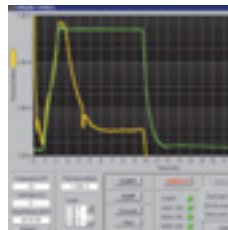

### RGA Guaranteed Ultimate Vacuum

- The pump is vacuum processed at 450 °C to outgas most of gases out of the pump body.
- The pump is shipped under vacuum.
- An RGA spectrum is available for each pump, to guarantee its performance and the cleanliness of the manufacturing process.

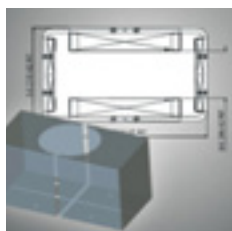

**Dedicated Magnetic Stray Shields**

- External magnetic shields for stray magnetic field reduction available.



**New Feedthrough and New Cables**

- New HV Safety Interlock prevents any chance of electrical shock.
- The voltage is automatically cut off as soon as the cable is disconnected from the pump.
- Safer pump operation.



**Dedicated Heaters**

- Dedicated Heater for every pump size.
- The new heaters are designed to perform a more effective pump baking.
- Lower power and operational costs.



**Optical Baffle**

Built-in Optical Baffle (optional) for:

- Minimized particle emission.
- Minimum conductance reduction.
- Total column protection.
- Maximum e-gun life.

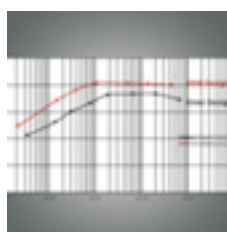

**Higher Pumping Speed**

- Optimized magnetic circuit for max. performance in a very compact package.
- Faster pump down.

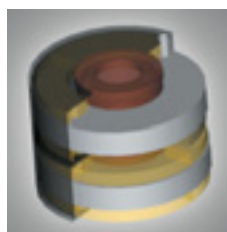

**Available in Round Shape**

Integrated ion pump/column allows:

- Optimum mass balancing.
- Improved pumping conductance.
- Compact and modular design.
- Symmetric weight distribution for rugged column integration.



**Battery Power Supply**

- Enables service without breaking vacuum.
- Allows for column shipping under vacuum.



**IPCU3 / IPCU 2 Power Supplies**

Two versions available: 3 or 2 supply channels.

- Special low noise electronics for better SEM imaging.
- Battery backup (optional): up to 30 days 24/7 of battery life.
- Pressure reading down to  $10^{-10}$  range.
- Optional display and front panel.



# Typical Applications for Vaclon *Plus* Pumps

## High Energy Physics

### Particle Accelerators & Synchrotron Light Sources

In these machines, electrically charged particles (electrons for the production of synchrotron light or ions for particle accelerators) are forced to follow a curved trajectory in a ring called a storage ring. Charged particles circulate for hours in the storage ring, at constant energy, in an ultra-high vacuum environment.

Before their injection into the storage ring, the particles first have to be accelerated inside an injection system composed of one or two accelerators (the Linac and the Booster). All along their path within the machine, the particles (electrons or ions) have to circulate inside a vacuum chamber. Otherwise, they would collide with the air molecules and would be absorbed very rapidly.

- **Linac**

The linac is a linear accelerator. The charged particles enter into a first RF cavity which accelerates them and at the same time groups them into bunches. They are then accelerated by a succession of RF cavities throughout the length of the linac. Vacuum within the linac can be created by Varian Vaclon *Plus* pumps from 20 l/s to 70 l/s.

- **Booster**

Charged particles, which have already been accelerated in the linac, are accelerated even more strongly by the booster. The acceleration is produced by RF cavities through which the charged particles pass many times, gaining in energy at each pass. Once the level of maximum energy has been reached, the beam of particles is transferred from the booster to the storage ring.



Courtesy: LBNL Advanced Light Source.

Vacuum in the booster is generally produced by small pumps. Small Varian Vaclon *Plus* pumps fit this application perfectly.

- **Storage Ring**

Charged particles circulate inside the storage ring at constant energy. All along the ring there are curved



Courtesy CERN.

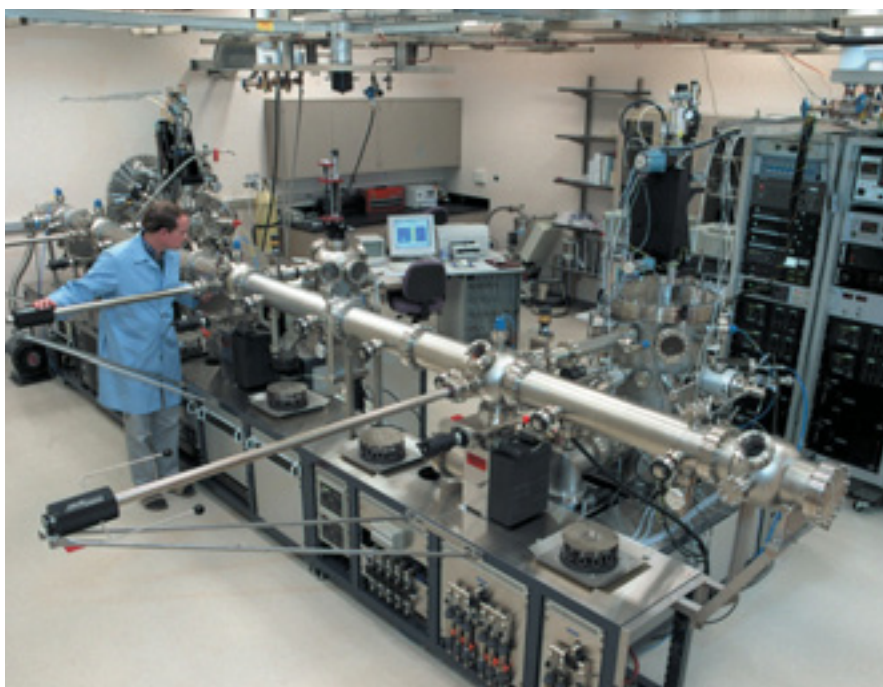

Courtesy Pacific Northwest National Laboratory.

sections as well as straight sections. The storage ring is placed inside a tunnel with very thick concrete walls in order to contain emitted radiation in case of beam loss. Ultra high vacuum is an absolute necessity in this part of the machine since the particles travel through the storage ring for hours. The less residual gas there is, the more focused the beam remains. Large Varian Vaclon *Plus* pumps, in the 300 - 500 l/s range are used for this demanding application.

- **Front Ends**

The front end is the pipe work which transports the particles under a vacuum from the extraction zone up to the beamline outside of the tunnel of the ring. There you can find a beam shutter as well as devices allowing the isolation of the vacuum of the ring from that of the beamline, which is often of lower pressure. Varian large pumps, as in for the storage ring, can be used in this part of the machine.

- **Beam Lines**

The experimental hall, around the storage ring, houses the beamlines built tangentially to the ring. The beamlines are usually specialized in a field of research (such as biology, polymers, and magnetism) or an experimental method (such as diffraction, EXAFS, and imaging). Some of the longest beamlines are built outside the experimental hall. Generally, large pumps are used in this part, from 300 l/s to 500 l/s. They can be combined with TSP and cryopanel in order to pump even the lightest molecules.

- **Miscellaneous Projects**

Some fundamental research projects that use very sensitive



Courtesy P. Ginter - ESRF Grenoble.



Courtesy P. Ginter - ESRF Grenoble.

equipment (necessitating ultra-high vacuum with no mechanical vibration) will find the solution in Varian Vaclon *Plus* pumps. The new gravitational waves detectors (GWD) such as VIRGO in Italy and LIGO in the USA use Varian pumps to produce and maintain the required vacuum.

## Instrumentation

- Analytical systems that use focused charged particle beams (CPB) and certain types of mass spectrometers such as magnetic sector or Fournier Transfer often require ultra-high vacuum.
- These applications have very stringent performance requirements for sensitivity, resolution, sample throughput and measurement repeatability. These requirements are driven by the need to analyze ever-smaller samples, especially in semiconductor, manufacturing, and other high-tech applications.
- In general these applications require very clean vacuum pumping, and only Vaclon pumps can certify the required level of cleanliness because Varian is the only ion pump manufacturer that bakes each pump in a vacuum furnace, and supply each pump with an RGA scan.



Courtesy PSI SLS.

# Typical Applications for Vaclon *Plus* Pumps

- Varian offers a full range of pumps, from 0.4 l/s up to 500 l/s, as well as combination and custom pumps so analytical system designers can meet all their vacuum requirements from one supplier.
- 50 years of ion pump experience makes Varian uniquely qualified to supply customized solutions for special applications.

## Nanotechnologies

- Varian's line of high performance Vaclon ion pumps are well suited for the vacuum requirements of Transmission Electron Microscopes (TEM), Scanning Electron Microscopes (SEM), Focused Ion Beam (FIB) and Surface Analysis equipments.
- **Varian is the only manufacturer to offer SEM application specific ion pumps.**
- The Diode SEM pump with its extremely low leakage current is ideal for the gun section of the column.
- The StarCell® pump element with its unique design is the ideal solution for the high pressure operation of the columns. StarCell is also the best pump for noble gases or hydrogen.
- Varian completes its offering to the microscope manufacture with a full line of controller/power supplies including the low cost power supplies and the full feature, multiple controllers.
- With the addition of Varian complete line of turbo pumps – ideal for sample chamber vacuum requirements – and roughing pumps, Varian can supply all the vacuum components required for electron microscopes.



Supply Chain Partner  
Carl Zeiss SMT AG

- Carl Zeiss SMT, global leader in light, electron and ion-optical technologies for industry and R&D, has designated Varian Vacuum Technologies as a Carl Zeiss SMT Supply Chain Partner.

## Industrial Vacuum Processes

Different applications in industrial sectors such as telecommunication, defense, medical and others make use of Vaclon pumps to process and maintain essential components under vacuum. Most of the core equipment in these sectors requires the use of different electron devices including:

- **Microwave tubes and devices**
- **Power grid tubes**
- **X-ray imaging tubes and devices**
- **X-ray sources**

In the processing cycle of these types of electron devices, small ion pumps from 8 l/s to 50 l/s are being used. Special tube sizes or special applications may require even bigger ion pumps up to 300-500 l/s. Vaclon pumps are often being used in combination with Turbo Molecular Pumps, backing pumps and other components out of the wide range of Varian products.

After processing, frequently these electron devices are being equipped with so-called appendage ion pumps in the range of 0.2 l/s to 8 l/s for the purpose of maintaining the electron tube under vacuum for its operational lifetime. The first ion pump was invented by Varian in the late 1950's,



Supply Chain Partner  
Carl Zeiss SMT AG

for the production of high-quality vacuum tubes used in radar technology. From this point on, Vaclon pumps set the pace in the industrial field for a wide range of applications using vacuum processed electron devices used worldwide in:

- **Space**

Electron devices are essential to various space programs, from satellite services and earth observation satellites to space probes. Microwave tubes and devices are vital tools, which link people and satellites in order to enable global communications. Spaceborne tubes are the power generators for the transponders carried on satellites. They retransmit TV or telecommunication signals back to the ground. The electron tubes used for this application are Travelling Wave Tubes. In these tubes, amplification is produced under vacuum by the interaction between a beam of electrons and the Radio-Frequency (RF) wave.

- **Telecommunications**

Microwave tubes, devices like Traveling Wave Tubes (TWTs) and Klystrons (powerful radio vacuum tubes) are widely used in civil and military telecommunication networks and equipment used for:

- **Satellite and terrestrial communication**
- **High data-rate transmissions for High Speed Internet and Wireless Cable**
- **Broadband high speed data**
- **Point-to-point and point-to-multipoint microwave links**

- **Broadcast**

Radio and TV broadcasters and transmitter manufacturers use electron devices in their equipment to enable high power transmission or digital broadcasting. Power grid tubes or microwave tubes are being used in AM radio, FM radio, VHF TV, UHF TV or digital TV transmitters and amplifiers.

- **Medical**

Radiological equipment manufacturers use electron devices for critical components in the radiological chain, such as X-ray

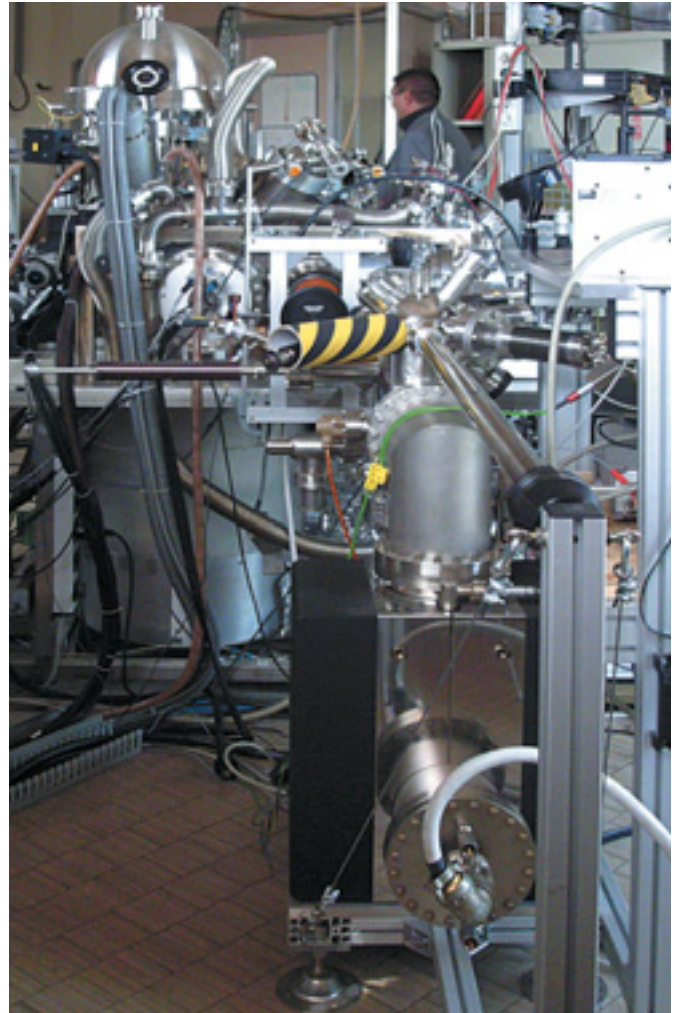

*Courtesy University of Modena.*

image intensifiers and radiological imaging units for diagnostics, as well as medical linear accelerators for radiation therapy. Typical fields of application include:

- **Medical Imaging (X-ray image tubes and devices)**
- **Radiation Therapy (high power Klystrons, LINAC)**
- **Magnetic Resonance Imaging**

- **Defense**

Microwave tubes and devices are key components in equipment and systems used for different defense applications:

- **Radar (ground based or airborne)**
- **Electronic Countermeasures (ECM)**
- **Smart Weapons & Electronic Warfare**
- **Missile guidance & Missile seekers**

- **Industrial and Others**

Several industrial processes make use of RF & Microwave tubes. Some examples are heat treating, Plastic welding, Food processing, Textile manufacturing, Film curing & drying. Other applications make use of X-ray tubes for non-destructive testing methods.

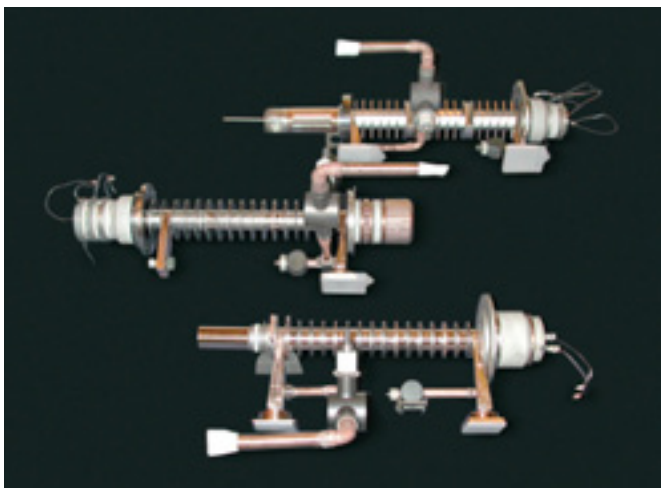

*Courtesy CPI.*

# Pump Models

	Miniature Pump	2 lt/sec Pump	8 lt/sec Pump	Vaclon Plus 20			Vaclon Plus 40		
Inlet Flange				2 3/4" OD CFF (NW 35)			2 3/4" OD CFF (NW 35)		
Element Type	Diode	Diode	Diode	StarCell®	Noble Diode	Diode	StarCell®	Noble Diode	Diode
Pumping Speed (L/S) (Saturated Pump at 1 <sup>-6</sup> mbar)									
Nitrogen	0.2	2	8	20	22	27	34	36	40
Operating Life (Hours) (at 1 <sup>-6</sup> mbar)	N/A	8,000	40,000	80,000	50,000	50,000	80,000	50,000	50,000
Maximum Starting Pressure (mbar)	1 x 10 <sup>-4</sup>	1 x 10 <sup>-4</sup>	≤ 1 x 10 <sup>-4</sup>	<10 <sup>-2</sup>	<10 <sup>-3</sup>	<10 <sup>-3</sup>	<10 <sup>-2</sup>	<10 <sup>-3</sup>	<10 <sup>-3</sup>
Maximum Baking Temperature (°C)	400 (without magnet) 150 (with magnet)	400 (without magnet) 150 (with magnet)	350	350	350	350	350	350	350
Weight kg (lbs)	Net 0.3 (0.66) Shipping 0.6 (1.33)	Net 0.3 (0.66) Shipping 0.6 (1.33)	Without magnet 4 (9)	Net 7 (15) Shipping 11 (24)			Net 17 (37) Shipping 21 (46)		
SEM Version Available on Request	-	-	-			•			•
<b>Controllers</b>									
Dual	-	-	-			•			•
MiniVac	•	•	•			•			•



Vaclon Plus 55			Vaclon Plus 75			Vaclon Plus 150			Vaclon Plus 300			Vaclon Plus 500		
4 1/2" OD CFF (NW 63)			6" OD CFF (NW 100)			6" OD CFF (NW 100)			8" OD CFF (NW 150)			8" OD CFF (NW 150)		
StarCell®	Noble Diode	Diode	StarCell®	Noble Diode	Diode	StarCell®	Noble Diode	Diode	StarCell®	Noble Diode	Diode	StarCell®	Noble Diode	Diode
50	53	55	65	68	75	125	135	150	240	260	300	410	440	500
80,000	50,000	50,000	80,000	50,000	50,000	80,000	50,000	50,000	80,000	50,000	50,000	80,000	50,000	50,000
<10 <sup>-2</sup>	<10 <sup>-3</sup>	<10 <sup>-3</sup>	<10 <sup>-2</sup>	<10 <sup>-3</sup>	<10 <sup>-3</sup>	<10 <sup>-2</sup>	<10 <sup>-3</sup>	<10 <sup>-3</sup>	<10 <sup>-2</sup>	<10 <sup>-3</sup>	<10 <sup>-3</sup>	<10 <sup>-2</sup>	<10 <sup>-3</sup>	<10 <sup>-3</sup>
350	350	350	350	350	350	350	350	350	350	350	350	350	350	350
Net 18 (39) Shipping 22 (48)			Net 19 (42) Shipping 23 (51)			Net 43 (94) Shipping 53 (110)			Net 69 (149) Shipping 84 (185)			Net 120 (264) Shipping 135 (297)		
•			•			-			-			-		
•			•			•			•			•		
•			•			-			-			-		



Ion Pumps

# Vaclon Plus 20

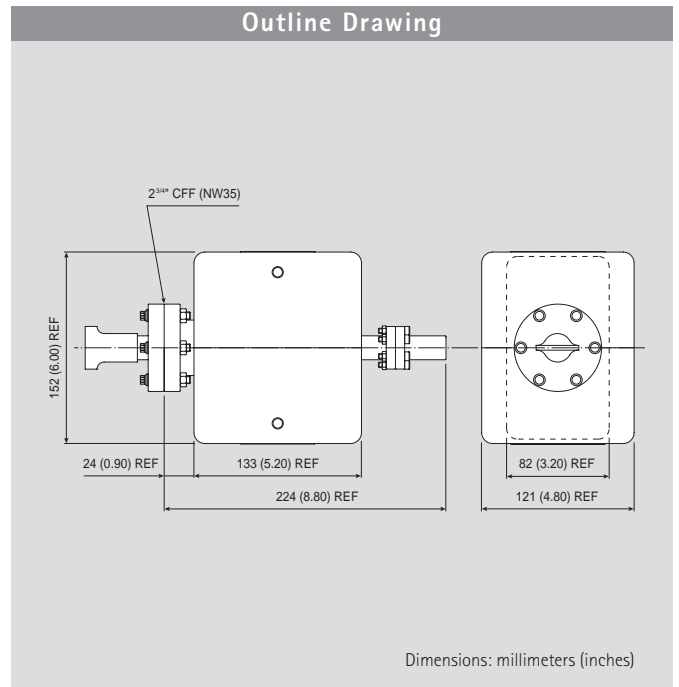

## Technical Specifications

	StarCell®	Noble Diode	Diode
Nominal pumping speed for Nitrogen (*) (l/s)	20	22	27
Operating life at 1x10 <sup>-6</sup> mbar (hours)	80,000	50,000	50,000
Maximum starting pressure (mbar)	≤ 5x10 <sup>-2</sup>	≤ 1x10 <sup>-3</sup>	
Ultimate pressure	Below 10 <sup>-11</sup>		
Inlet flange	2 3/4" CFF (NW 35) AISI 304 ESR SST		
Maximum baking temperature (°C)	350		
Weight, kg (lbs) (with ferrite magnet)	Net 7 (15), Shipping 11 (24)		

(\*) Tested according to ISO/DIS 3556-1-1992

SEM version available on request

Vaclon Plus 20 - Pumping Speed vs Pressure

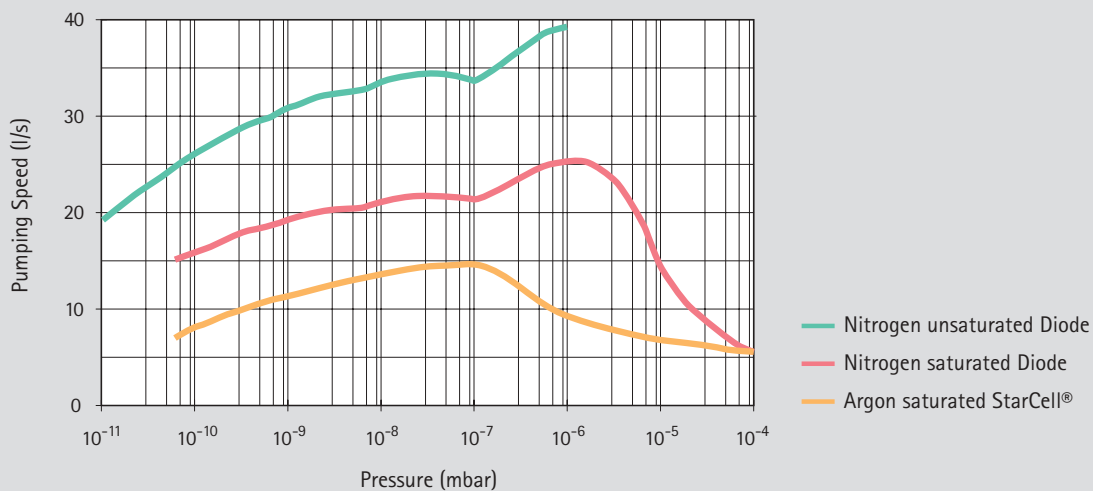

Ordering Information

Description	Part Number	
<b>Pumps</b>		
Diodewith Ferrite magnets	120 V	9191115
Diode without magnets	120 V	9191114
StarCell® with Ferrite magnets	120 V	9191145
StarCell® without magnets	120 V	9191144
<i>Noble Diode versions available on request</i>		
<b>Dual Controller</b> See also pages 31-32		
One Pump Negative	120 V	9297000
Two Pumps Negative	120 V	9297001
One Pump Positive	120 V	9297002
Two Pumps Positive	120 V	9297003
One Pump Negative	220 V	9297004
Two Pumps Negative	220 V	9297005
One Pump Positive	220 V	9297006
Two Pumps Positive	220 V	9297007
<b>MiniVac Controller</b> See also page 33		
MiniVac	120 V	9290191
MiniVac	220 V	9290290

Description	Part Number	
<b>HV Cables</b>		
HV Bakeable cable, radiation resistant, 4 m (13 ft.) long, with interlock		9290705
HV Bakeable cable, radiation resistant, 7 m (23 ft.) long, with interlock		9290707
HV Bakeable cable, radiation resistant, 10 m (33 ft.) long, with interlock		9290708
HV Bakeable cable, radiation resistant, 20 m (66 ft.) long, with interlock		9290709
<b>Replacement Parts</b>		
HV Feedthrough with interlock		9595125
Vaclon Plus 20 Diode Ferrite magnet assembly		9191001
Vaclon Plus 20 Noble Diode Ferrite magnet assembly		9191002
Vaclon Plus 20 StarCell® Ferrite magnet assembly		9191004
Heaters* (Input Power 140 W)	120 V	9191110
Heaters* (Input Power 140 W)	220 V	9191111

\*To order heaters for replacement or upgrading of existing pumps, please contact your local Varian Vacuum Technologies representative.

Diode, Noble Diode	positive
StarCell®, Triode	negative
(see page 40)	

# Vaclon Plus 40

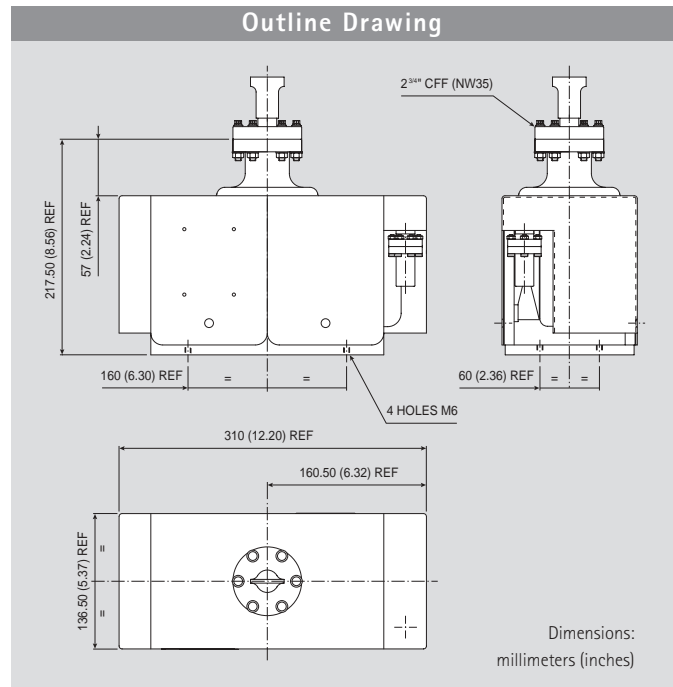

## Technical Specifications

	StarCell®	Noble Diode	Diode
Nominal pumping speed for Nitrogen (*) (l/s)	34	36	40
Operating life at 1x10 <sup>-6</sup> mbar (hours)	80,000	50,000	50,000
Maximum starting pressure (mbar)	≤ 5x10 <sup>-2</sup>	≤ 1x10 <sup>-3</sup>	
Ultimate pressure	Below 10 <sup>-11</sup>		
Inlet flange	2 3/4" CFF (NW 35) AISI 304 ESR SST		
Maximum baking temperature (°C)	350		
Weight, kg (lbs)	17 (37)		

(\*) Tested according to ISO/DIS 3556-1-1992

SEM version available on request

Vaclon Plus 40 - Pumping Speed vs Pressure

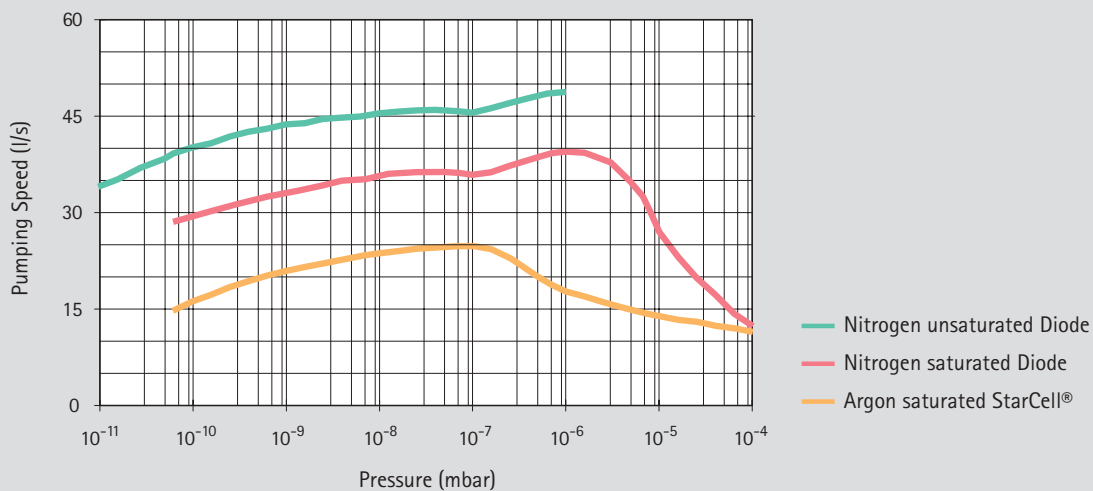

Ordering Information

Description	Part Number
<b>Pumps</b>	
Diode	9191210
Diode with additional 2 3/4" CFF port	9191213
Diode without magnets	9191214
StarCell®	9191240
StarCell® with additional 2 3/4" CFF port	9191243
StarCell® without magnets	9191244
<i>Noble Diode versions available on request</i>	
<b>Dual Controller</b> See also pages 31-32	
One Pump Negative	120 V 9297000
One Pump Negative	220 V 9297004
One Pump Positive	120 V 9297002
One Pump Positive	220 V 9297006
<b>MiniVac Controller</b> See also page 33	
MiniVac	120 V 9290191
MiniVac	220 V 9290290

Description	Part Number
<b>HV Cables</b>	
HV Bakeable cable, radiation resistant, 4 m (13 ft.) long, with interlock	9290705
HV Bakeable cable, radiation resistant, 7 m (23 ft.) long, with interlock	9290707
HV Bakeable cable, radiation resistant, 10 m (33 ft.) long, with interlock	9290708
HV Bakeable cable, radiation resistant, 20 m (66 ft.) long, with interlock	9290709
<b>Replacement Parts</b>	
HV Feedthrough with interlock	9595125
Heaters*/** (Input Power 250 W)	120 V 9190071
Heaters*/** (Input Power 250 W)	220 V 9190070

\* To order heaters for replacement or upgrading of existing pumps, please contact your local Varian Vacuum Technologies representative.

\*\*cCSAus marked version available on request.

Diode, Noble Diode	positive
StarCell®, Triode	negative
(see page 40)	

# Vaclon Plus 55

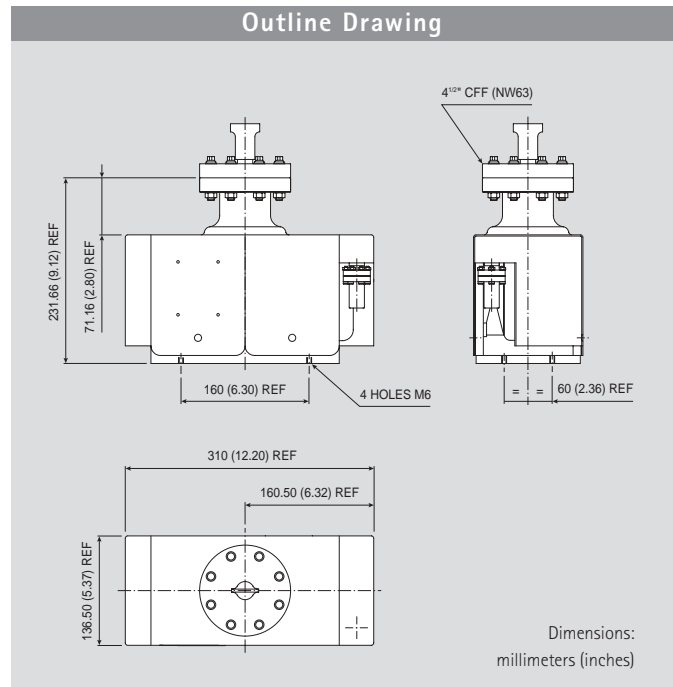

## Technical Specifications

	StarCell®	Noble Diode	Diode
Nominal pumping speed for Nitrogen (*) (l/s)	50	53	55
Operating life at 1x10 <sup>-6</sup> mbar (hours)	80,000	50,000	50,000
Maximum starting pressure (mbar)	≤ 5x10 <sup>-2</sup>	≤ 1x10 <sup>-3</sup>	
Ultimate pressure	Below 10 <sup>-11</sup>		
Inlet flange	4 1/2" CFF (NW 63) AISI 304 ESR SST		
Maximum baking temperature (°C)	350		
Weight, kg (lbs)	18 (39)		

(\*) Tested according to ISO/DIS 3556-1-1992

SEM version available on request

Vaclon Plus 55 - Pumping Speed vs Pressure

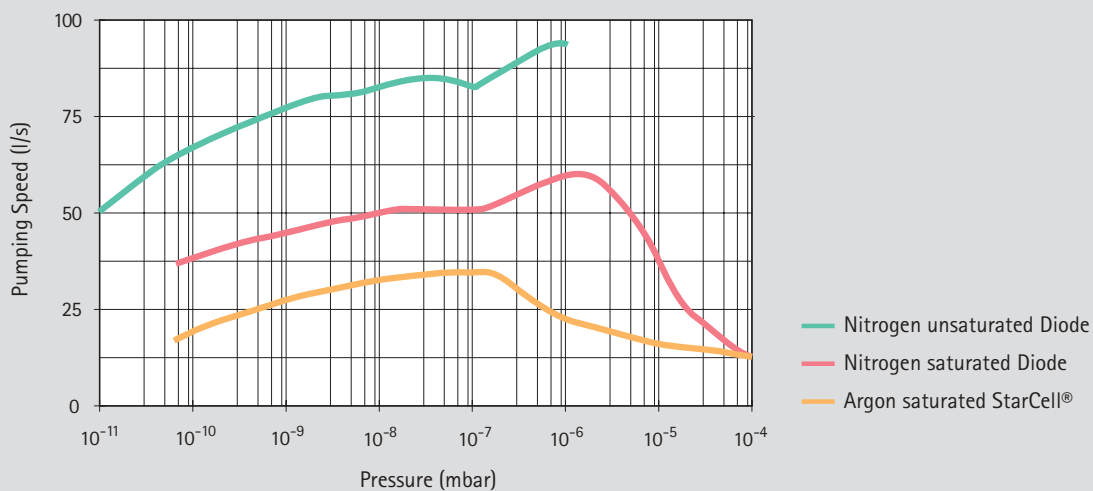

Ordering Information

Description	Part Number
<b>Pumps</b>	
Diode	9191310
Diode with additional 2 3/4" CFF port	9191313
Diode without magnets	9191314
StarCell®	9191340
StarCell® with additional 2 3/4" CFF port	9191343
StarCell® without magnets	9191344
<i>Noble Diode versions available on request</i>	
<b>Dual Controller</b> See also pages 31-32	
One Pump Negative	120 V 9297000
One Pump Negative	220 V 9297004
One Pump Positive	120 V 9297002
One Pump Positive	220 V 9297006
<b>MiniVac Controller</b> See also page 33	
MiniVac	120 V 9290191
MiniVac	220 V 9290290

Description	Part Number
<b>HV Cables</b>	
HV Bakeable cable, radiation resistant, 4 m (13 ft.) long, with interlock	9290705
HV Bakeable cable, radiation resistant, 7 m (23 ft.) long, with interlock	9290707
HV Bakeable cable, radiation resistant, 10 m (33 ft.) long, with interlock	9290708
HV Bakeable cable, radiation resistant, 20 m (66 ft.) long, with interlock	9290709
<b>Replacement Parts</b>	
HV Feedthrough with interlock	9595125
Heaters*/** (Input Power 250 W)	120 V 9190071
Heaters*/** (Input Power 250 W)	220 V 9190070

\* To order heaters for replacement or upgrading of existing pumps, please contact your local Varian Vacuum Technologies representative.

\*\*cCSAus marked version available on request.

Diode, Noble Diode	positive
StarCell®, Triode	negative
(see page 40)	

# Vaclon Plus 75

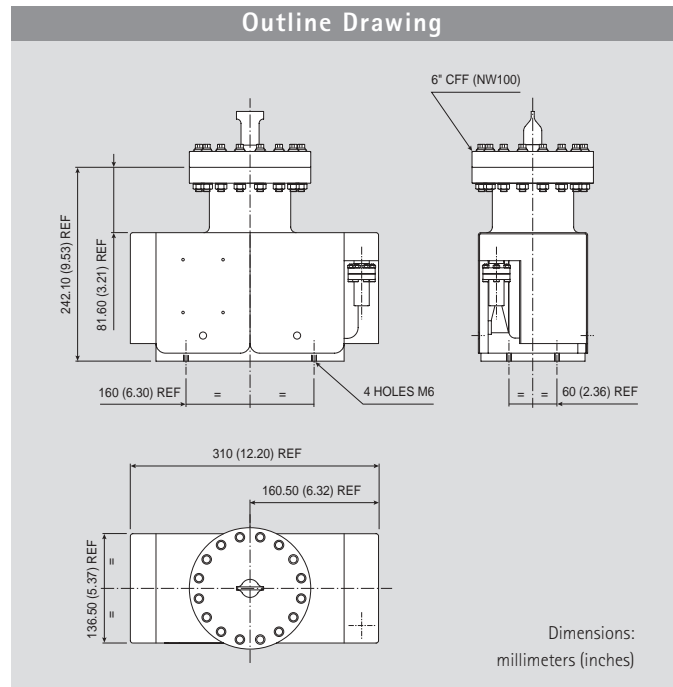

## Technical Specifications

	StarCell®	Noble Diode	Diode
Nominal pumping speed for Nitrogen (*) (l/s)	65	68	75
Operating life at 1x10 <sup>-6</sup> mbar (hours)	80,000	50,000	50,000
Maximum starting pressure (mbar)	≤ 5x10 <sup>-2</sup>	≤ 1x10 <sup>-3</sup>	
Ultimate pressure	Below 10 <sup>-11</sup>		
Inlet flange	6" CFF (NW 100) AISI 304 ESR SST		
Maximum baking temperature (°C)	350		
Weight, kg (lbs)	19 (42)		

(\*) Tested according to ISO/DIS 3556-1-1992

SEM version available on request

Vaclon Plus 75 - Pumping Speed vs Pressure

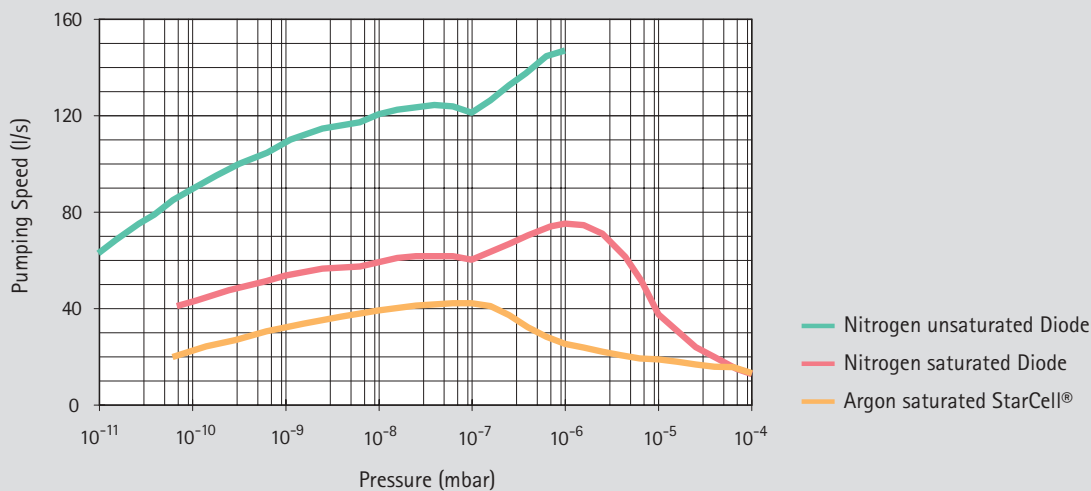

Ordering Information

Description	Part Number
<b>Pumps</b>	
Diode	9191410
Diode with additional 2 3/4" CFF port	9191413
Diode without magnets	9191414
StarCell®	9191440
StarCell® with additional 2 3/4" CFF port	9191443
StarCell® without magnets	9191444
<i>Noble Diode versions available on request</i>	
<b>Dual Controller</b> See also pages 31-32	
One Pump Negative	120 V 9297000
One Pump Negative	220 V 9297004
One Pump Positive	120 V 9297002
One Pump Positive	220 V 9297006
<b>MiniVac Controller</b> See also page 33	
MiniVac	120 V 9290191
MiniVac	220 V 9290290

Description	Part Number
<b>HV Cables</b>	
HV Bakeable cable, radiation resistant, 4 m (13 ft.) long, with interlock	9290705
HV Bakeable cable, radiation resistant, 7 m (23 ft.) long, with interlock	9290707
HV Bakeable cable, radiation resistant, 10 m (33 ft.) long, with interlock	9290708
HV Bakeable cable, radiation resistant, 20 m (66 ft.) long, with interlock	9290709
<b>Replacement Parts</b>	
HV Feedthrough with interlock	9595125
Heaters*/** (Input Power 250 W)	120 V 9190071
Heaters*/** (Input Power 250 W)	220 V 9190070

\* To order heaters for replacement or upgrading of existing pumps, please contact your local Varian Vacuum Technologies representative.

\*\*cCSAus marked version available on request.

Diode, Noble Diode	positive
StarCell®, Triode	negative
(see page 40)	

# Vaclon Plus 150

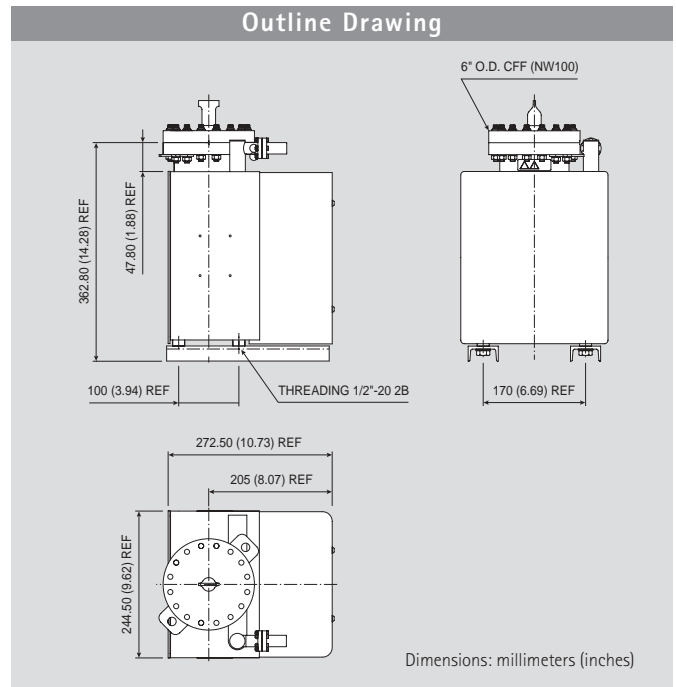

## Technical Specifications

	StarCell®	Noble Diode	Diode
Nominal pumping speed for Nitrogen (*) (l/s)	125	135	150
Operating life at 1x10 <sup>-6</sup> mbar (hours)	80,000	50,000	50,000
Maximum starting pressure (mbar)	≤ 1x10 <sup>-2</sup>	≤ 1x10 <sup>-3</sup>	
Ultimate pressure	Below 10 <sup>-11</sup>		
Inlet flange	6" CFF (NW 100) AISI 304 ESR		
Maximum baking temperature (°C)	350		
Weight, kg (lbs)	43 (94)		

(\*) Tested according to ISO/DIS 3556-1-1992

Vaclon Plus 150 – Pumping Speed vs Pressure

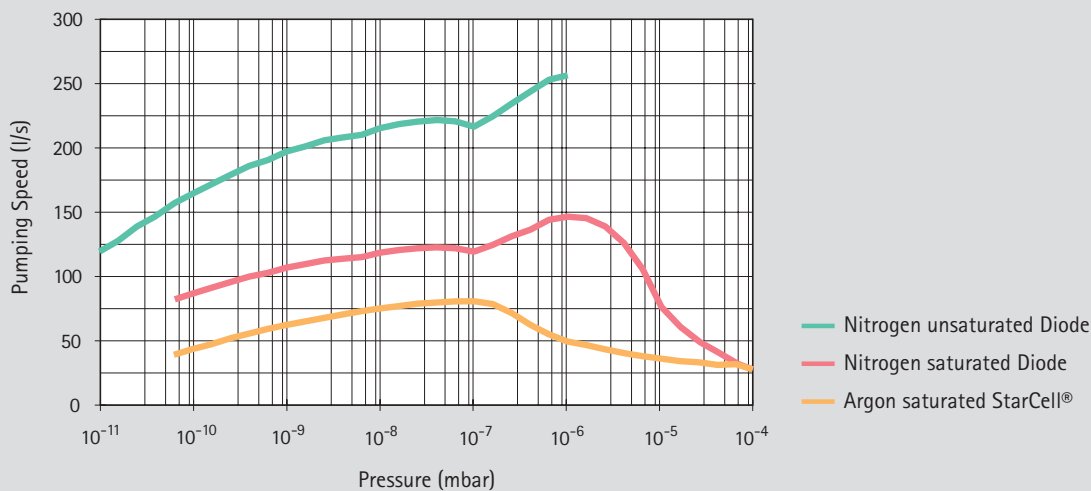

Ordering Information

See pages 28-30 for Vaclon Plus combination pumps.

Description	Part Number
<b>Pumps</b>	
Diode	9191510
Diode with heaters installed	120 V 9191511
Diode with heaters installed	220 V 9191512
Diode double-ended	9191550
Diode double-ended with heaters installed	120 V 9191551
Diode double-ended with heaters installed	220 V 9191552
StarCell®	9191540
StarCell® with heaters installed	120 V 9191541
StarCell® with heaters installed	220 V 9191542
StarCell® double-ended	9191580
StarCell® double-ended with heaters installed	120 V 9191581
StarCell® double-ended with heaters installed	220 V 9191582
<i>Noble Diode versions available on request</i>	
<b>Dual Controller</b> See also pages 31-32	
One Pump Negative	120 V 9297000
One Pump Negative	220 V 9297004
One Pump Positive	120 V 9297002
One Pump Positive	220 V 9297006

Description	Part Number
<b>MiniVac Controller</b> See also page 33	
MiniVac	120 V 9290191
MiniVac	220 V 9290290
<b>HV Cables</b>	
HV Bakeable cable, radiation resistant, 4 m (13 ft.) long, with interlock	9290705
HV Bakeable cable, radiation resistant, 7 m (23 ft.) long, with interlock	9290707
HV Bakeable cable, radiation resistant, 10 m (33 ft.) long, with interlock	9290708
HV Bakeable cable, radiation resistant, 20 m (66 ft.) long, with interlock	9290709
<b>Replacement Parts</b>	
HV Feedthrough with interlock	9595125
Pumping element* Diode	9199040
Pumping element* Noble Diode	9199045
Pumping element* StarCell®	9199030
Heaters** (Input Power 480 W)	120 V 9190073
Heaters** (Input Power 480 W)	220 V 9190072

\* Quantity required: 2.

\*\*To order heaters for replacement or upgrading of existing pumps, please contact your local Varian Vacuum Technologies representative.

Diode, Noble Diode	positive
StarCell®, Triode	negative
(see page 40)	

# Vaclon Plus 300

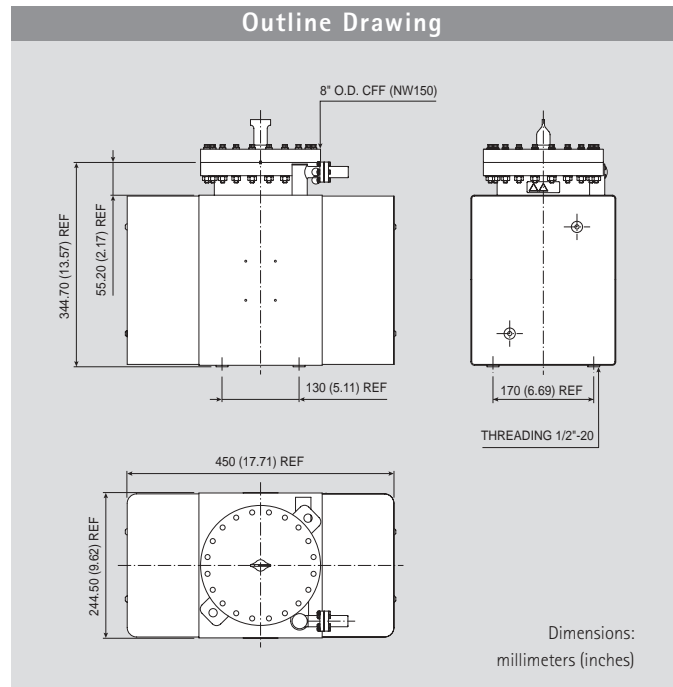

## Technical Specifications

	StarCell®	Noble Diode	Diode
Nominal pumping speed for Nitrogen (*) (l/s)	240	260	300
Operating life at 1x10 <sup>-6</sup> mbar (hours)	80,000	50,000	50,000
Maximum starting pressure (mbar)	≤ 1x10 <sup>-2</sup>	≤ 1x10 <sup>-3</sup>	
Ultimate pressure	Below 10 <sup>-11</sup>		
Inlet flange	8" CFF (NW 150) AISI 304 ESR		
Maximum baking temperature (°C)	350		
Weight, kg (lbs)	69 (149)		

(\*) Tested according to ISO/DIS 3556-1-1992

Vaclon Plus 300 – Pumping Speed vs Pressure

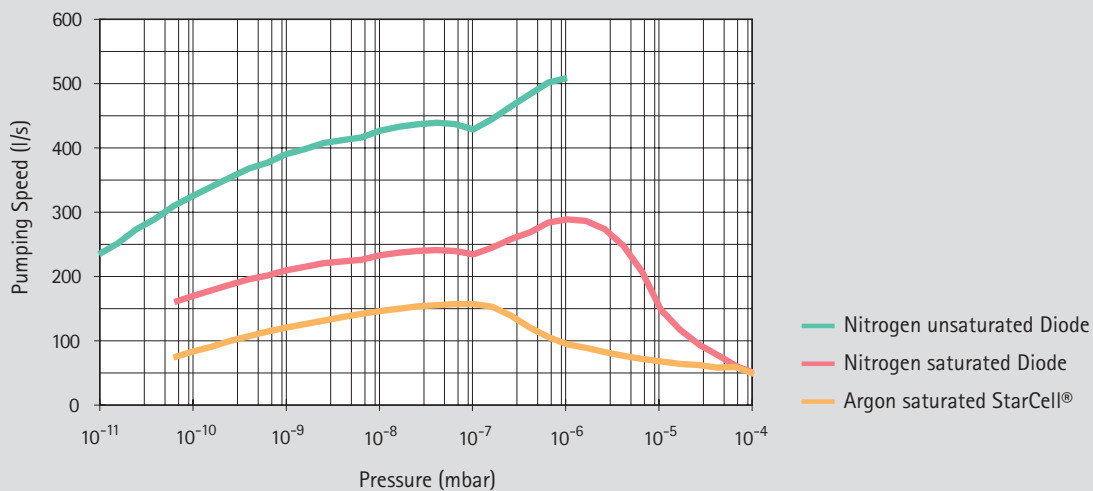

Ordering Information

See pages 28-30 for Vaclon Plus combination pumps.

Description	Part Number
<b>Pumps</b>	
Diode	9191610
Diode with heaters installed 120 V	9191611
Diode with heaters installed 220 V	9191612
Diode double-ended	9191650
Diode double-ended with heaters installed 120 V	9191651
Diode double-ended with heaters installed 220 V	9191652
StarCell®	9191640
StarCell® with heaters installed 120 V	9191641
StarCell® with heaters installed 220 V	9191642
StarCell® double-ended	9191680
StarCell® double-ended with heaters installed 120 V	9191681
StarCell® double-ended with heaters installed 220 V	9191682
<i>Noble Diode versions available on request</i>	
<b>Dual Controller</b> See also pages 31-32	
One Pump Negative 120 V	9297000
One Pump Negative 220 V	9297004
One Pump Positive 120 V	9297002
One Pump Positive 220 V	9297006

Description	Part Number
<b>MiniVac Controller</b> See also page 33	
MiniVac 120 V	9290191
MiniVac 220 V	9290290
<b>HV Cables</b>	
HV Bakeable cable, radiation resistant, 4 m (13 ft.) long, with interlock	9290705
HV Bakeable cable, radiation resistant, 7 m (23 ft.) long, with interlock	9290707
HV Bakeable cable, radiation resistant, 10 m (33 ft.) long, with interlock	9290708
HV Bakeable cable, radiation resistant, 20 m (66 ft.) long, with interlock	9290709
<b>Replacement Parts</b>	
HV Feedthrough with interlock	9595125
Pumping element* Diode	9199040
Pumping element* Noble Diode	9199045
Pumping element* StarCell®	9199030
Heaters** (Input Power 580 W) 120 V	9190075
Heaters** (Input Power 580 W) 220 V	9190074

\* Quantity required: 4.

\*\*To order heaters for replacement or upgrading of existing pumps, please contact your local Varian Vacuum Technologies representative.

Diode, Noble Diode	positive
StarCell®, Triode	negative
(see page 40)	

# Vaclon Plus 500

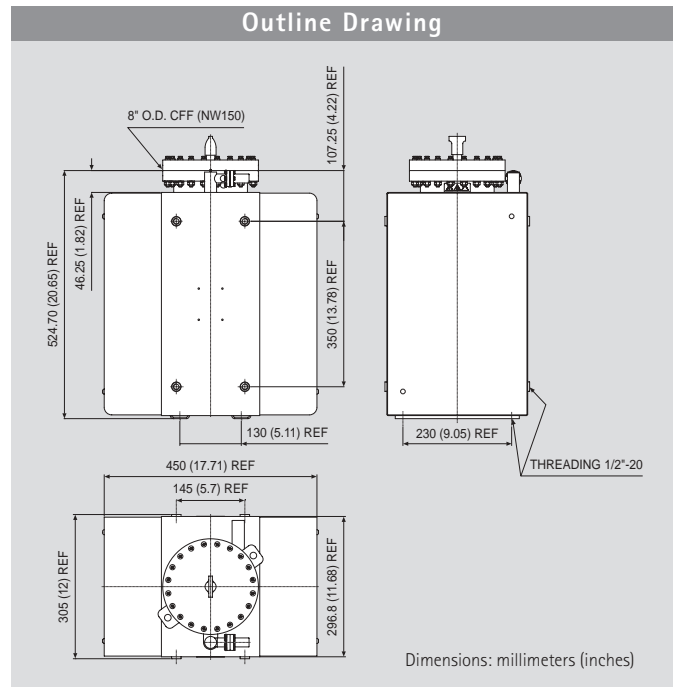

## Technical Specifications

	StarCell®	Noble Diode	Diode
Nominal pumping speed for Nitrogen (*) (l/s)	410	440	500
Operating life at 1x10 <sup>-6</sup> mbar (hours)	80,000	50,000	50,000
Maximum starting pressure (mbar)	≤ 1x10 <sup>-2</sup>	≤ 1x10 <sup>-3</sup>	
Ultimate pressure	Below 10 <sup>-11</sup>		
Inlet flange	8" CFF (NW 150) AISI 304 ESR		
Maximum baking temperature (°C)	350		
Weight, kg (lbs)	120 (264)		

(\*) Tested according to ISO/DIS 3556-1-1992

Vaclon Plus 500 – Pumping Speed vs Pressure

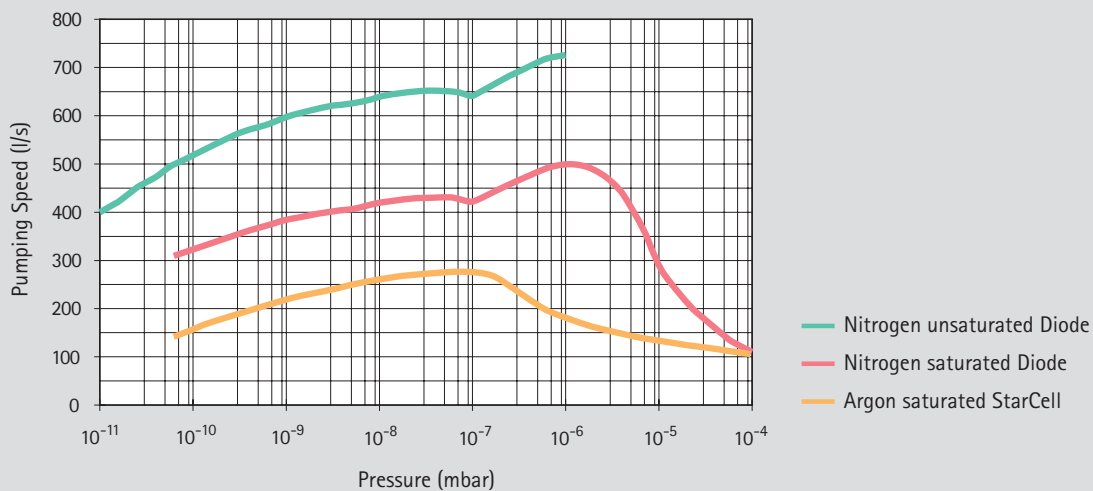

Ordering Information

See pages 28-30 for Vaclon Plus combination pumps.

Description	Part Number
<b>Pumps</b>	
Diode	9191710
Diode with heaters installed 120 V	9191711
Diode with heaters installed 220 V	9191712
Diode double-ended	9191750
Diode double-ended with heaters installed 120 V	9191751
Diode double-ended with heaters installed 220 V	9191752
StarCell®	9191740
StarCell® with heaters installed 120 V	9191741
StarCell® with heaters installed 220 V	9191742
StarCell® double-ended	9191780
StarCell® double-ended with heaters installed 120 V	9191781
StarCell® double-ended with heaters installed 220 V	9191782
<i>Noble Diode versions available on request</i>	
<b>Dual Controller</b> See also pages 31-32	
One Pump Negative 120 V	9297000
One Pump Negative 220 V	9297004
One Pump Positive 120 V	9297002
One Pump Positive 220 V	9297006

Description	Part Number
<b>MiniVac Controller</b> See also page 33	
MiniVac 120 V	9290191
MiniVac 220 V	9290290
<b>HV Cables</b>	
HV Bakeable cable, radiation resistant, 4 m (13 ft.) long, with interlock	9290705
HV Bakeable cable, radiation resistant, 7 m (23 ft.) long, with interlock	9290707
HV Bakeable cable, radiation resistant, 10 m (33 ft.) long, with interlock	9290708
HV Bakeable cable, radiation resistant, 20 m (66 ft.) long, with interlock	9290709
<b>Replacement Parts</b>	
HV Feedthrough with interlock	9595125
Pumping element* Diode	9199040
Pumping element* Noble Diode	9199045
Pumping element* StarCell®	9199030
Heaters** (Input Power 780 W) 120 V	9190077
Heaters** (Input Power 780 W) 220 V	9190076

\* Quantity required: 8.  
 \*\*To order heaters for replacement or upgrading of existing pumps, please contact your local Varian Vacuum Technologies representative.

Diode, Noble Diode	positive
StarCell®, Triode	negative
(see page 40)	

# Vaclon *Plus* Combination Pumps



## Titanium Sublimation Combination Pumps

- Ion-Sublimation combination pumps have been a popular choice for many years for creating ultra high vacuum environments. The titanium sublimation creates extra high getterable gas pumping speed while the ion pumping mechanisms handle the non-getterable gases such as argon and methane.
- This combination pump is a Vaclon *Plus* 150, 300, or 500 with an extra side or bottom-mounted 8" ConFlat® port. The combination pump includes the cylindrical cryopanel and TSP source mounted to the extra port. Getterable gases enter the end of the cylindrical cryopanel and are pumped by being combined with the freshly-deposited titanium there. Liquid nitrogen cooling the cryopanel increases the efficiency of the getting process and adds greatly to the water pumping speed.
- The Varian Vaclon *Plus* series combination pumps allow addition of a cryopanel from the bottom of the pump or from the side. This can be a significant advantage in situations where height restrictions are present. Customized pump configurations are also available.

### Technical Specifications

Nominal net pumping speed at 20°C (l/s) with StarCell® elements (water cooled cryopanel)

Vaclon <i>Plus</i> 150	N <sub>2</sub> - 610 H <sub>2</sub> - 1,380
Vaclon <i>Plus</i> 300	N <sub>2</sub> - 720 H <sub>2</sub> - 1,580
Vaclon <i>Plus</i> 500	N <sub>2</sub> - 880 H <sub>2</sub> - 1,930

For cryopanel specifications, refer to pages 37-38.

### Outline Drawing

#### Vaclon *Plus* 150 Combination Pump (side-mounted TSP)

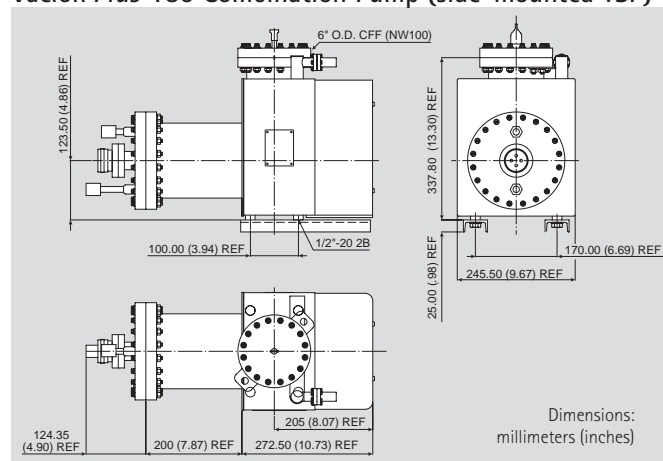

#### Vaclon *Plus* 300 Combination Pump (side-mounted TSP)

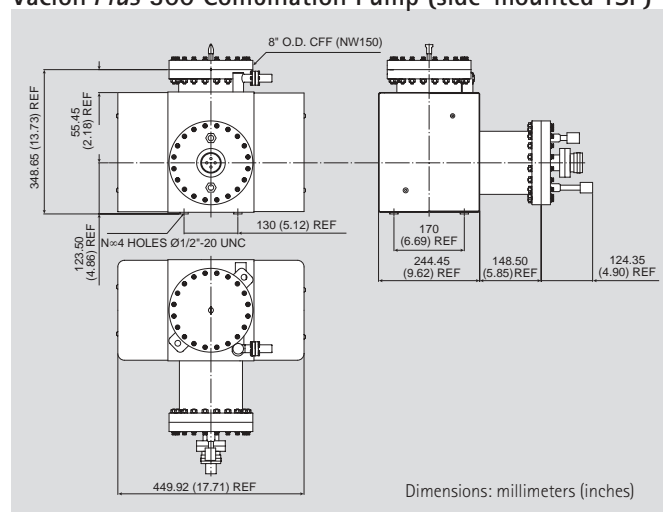

#### Vaclon *Plus* 500 Combination Pump (side-mounted TSP)

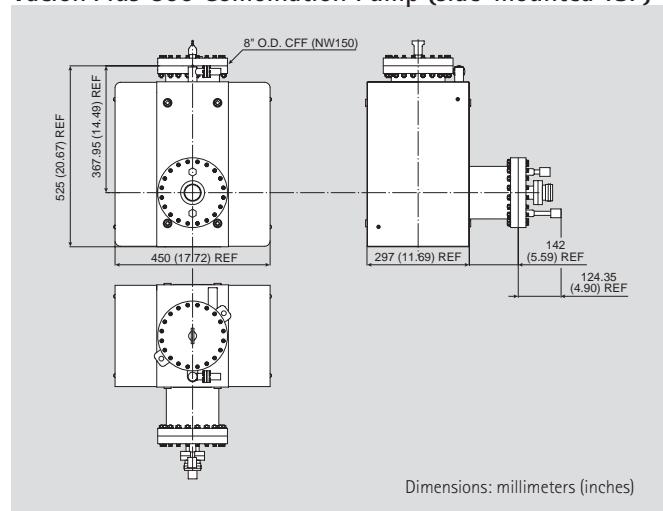

Outline Drawing

Vaclon Plus 300 Combination Pump (bottom-mounted TSP)

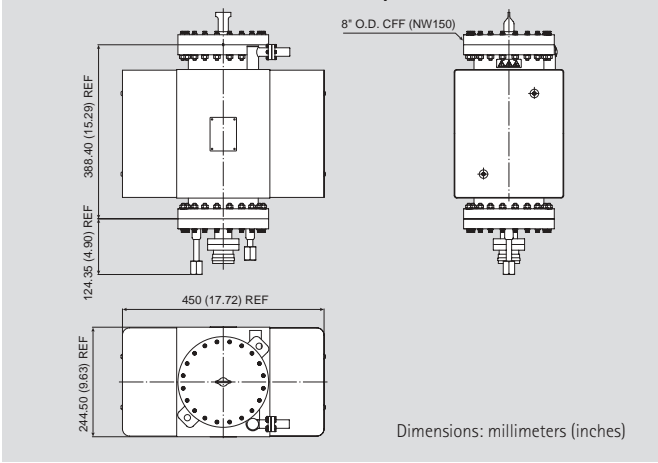

Vaclon Plus 500 Combination Pump (bottom-mounted TSP)

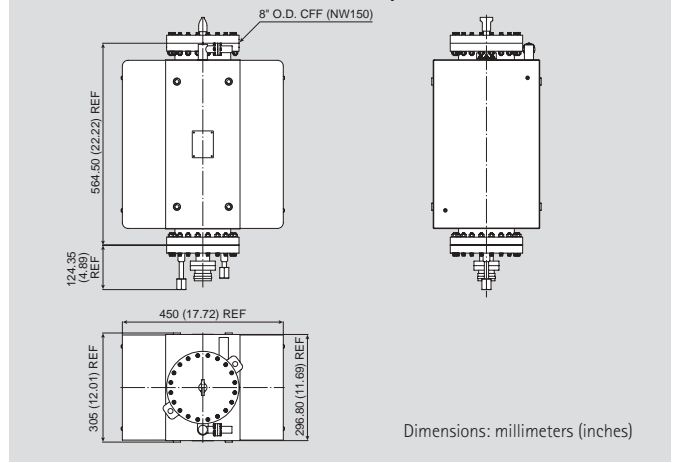

Combination Pumps Pumping Speed

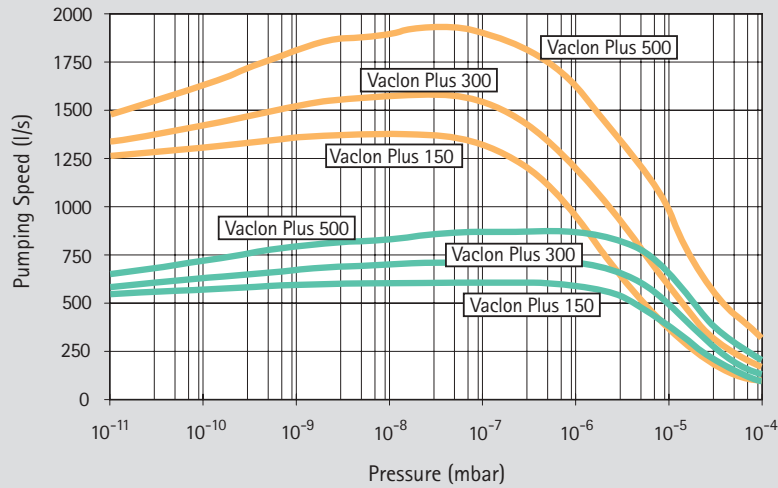

Ion Pumps

# Vaclon *Plus* Combination Pumps

## Ordering Information

The Vaclon *Plus* 500, 300, and 150 pumps can be supplied with the sublimation cryopanel factory-installed and TSP cartridge included. Cables and controllers are to be ordered separately. For basic pump part number, see pages 22 - 27.

Description		Part Number
<b>Vaclon <i>Plus</i> 500, 300, or 150 combination pump</b>		
Vaclon <i>Plus</i> 150 Diode, with Side-Mounted Cryopanel, with TSP Cartridge and with Installed Heater	120V	9192510
Vaclon <i>Plus</i> 150 Diode, with Side-Mounted Cryopanel, with TSP Cartridge and with Installed Heater	220V	9192511
Vaclon <i>Plus</i> 150 Noble Diode, with Side-Mounted Cryopanel, with TSP Cartridge and with Installed Heater	120V	9192520
Vaclon <i>Plus</i> 150 Noble Diode, with Side-Mounted Cryopanel, with TSP Cartridge and with Installed Heater	220V	9192521
Vaclon <i>Plus</i> 150 Starcell®, with Side-Mounted Cryopanel, with TSP Cartridge and with Installed Heater	120V	9192540
Vaclon <i>Plus</i> 150 Starcell®, with Side-Mounted Cryopanel, with TSP Cartridge and with Installed Heater	220V	9192541
Vaclon <i>Plus</i> 300 Diode, with Side-Mounted Cryopanel, with TSP Cartridge and with Installed Heater	120V	9192610
Vaclon <i>Plus</i> 300 Diode, with Side-Mounted Cryopanel, with TSP Cartridge and with Installed Heater	220V	9192611
Vaclon <i>Plus</i> 300 Noble Diode, with Side-Mounted Cryopanel, with TSP Cartridge and with Installed Heater	120V	9192620
Vaclon <i>Plus</i> 300 Noble Diode, with Side-Mounted Cryopanel, with TSP Cartridge and with Installed Heater	220V	9192621
Vaclon <i>Plus</i> 300 Starcell®, with Side-Mounted Cryopanel, with TSP Cartridge and with Installed Heater	120V	9192640
Vaclon <i>Plus</i> 300 Starcell®, with Side-Mounted Cryopanel, with TSP Cartridge and with Installed Heater	220V	9192641
Vaclon <i>Plus</i> 300 Diode, with Bottom-Mounted Cryopanel, with TSP Cartridge and with Installed Heater	120V	9192612
Vaclon <i>Plus</i> 300 Diode, with Bottom-Mounted Cryopanel, with TSP Cartridge and with Installed Heater	220V	9192613
Vaclon <i>Plus</i> 300 Noble Diode, with Bottom-Mounted Cryopanel, with TSP Cartridge and with Installed Heater	120V	9192622
Vaclon <i>Plus</i> 300 Noble Diode, with Bottom-Mounted Cryopanel, with TSP Cartridge and with Installed Heater	220V	9192623
Vaclon <i>Plus</i> 300 Starcell®, with Bottom-Mounted Cryopanel, with TSP Cartridge and with Installed Heater	120V	9192642
Vaclon <i>Plus</i> 300 Starcell®, with Bottom-Mounted Cryopanel, with TSP Cartridge and with Installed Heater	220V	9192643
Vaclon <i>Plus</i> 500 Diode, with Side-Mounted Cryopanel, with TSP Cartridge and with Installed Heater	120V	9192710
Vaclon <i>Plus</i> 500 Diode, with Side-Mounted Cryopanel, with TSP Cartridge and with Installed Heater	220V	9192711
Vaclon <i>Plus</i> 500 Noble Diode, with Side-Mounted Cryopanel, with TSP Cartridge and with Installed Heater	120V	9192720
Vaclon <i>Plus</i> 500 Noble Diode, with Side-Mounted Cryopanel, with TSP Cartridge and with Installed Heater	220V	9192721
Vaclon <i>Plus</i> 500 Starcell®, with Side-Mounted Cryopanel, with TSP Cartridge and with Installed Heater	120V	9192740
Vaclon <i>Plus</i> 500 Starcell®, with Side-Mounted Cryopanel, with TSP Cartridge and with Installed Heater	220V	9192741
Vaclon <i>Plus</i> 500 Diode, with Bottom-Mounted Cryopanel, with TSP Cartridge and with Installed Heater	120V	9192712
Vaclon <i>Plus</i> 500 Diode, with Bottom-Mounted Cryopanel, with TSP Cartridge and with Installed Heater	220V	9192713
Vaclon <i>Plus</i> 500 Noble Diode, with Bottom-Mounted Cryopanel, with TSP Cartridge and with Installed Heater	120V	9192722
Vaclon <i>Plus</i> 500 Noble Diode, with Bottom-Mounted Cryopanel, with TSP Cartridge and with Installed Heater	220V	9192723
Vaclon <i>Plus</i> 500 Starcell®, with Bottom-Mounted Cryopanel, with TSP Cartridge and with Installed Heater	120V	9192742
Vaclon <i>Plus</i> 500 Starcell®, with Bottom-Mounted Cryopanel, with TSP Cartridge and with Installed Heater	220V	9192743

Description		Weight kg (lbs)	Part Number
<b>Replacement Parts and Accessories</b>			
TSP Filament Cartridge on 2 3/4" CFF		2.7 (6.0)	9160050
Replacement filaments, package of 12 each		0.4 (2.0)	9160051
Titanium Sublimation Pump Control Unit (Order cables separately)	120V	17.7 (39.0)	9290022
Titanium Sublimation Pump Control Unit (Order cables separately)	220V	17.7 (39.0)	9290023
TSP Cartridge cable, 3.5 m (12 ft.)		9.1 (20.0)	9240730
Sublimation Cryopanel on 8" CFF		10.5 (23.0)	9190180

# Dual Controller



The new Dual ion pump controller is a state-of-the-art unit able to operate two different ion pumps simultaneously and independently. It is suited to start and operate ion pumps of any type (Diode, Noble Diode, StarCell®) and size (from 20 to 500 l/s). A large two line LCD display allows simultaneous reading of individual pump voltage, current and pressure, while the

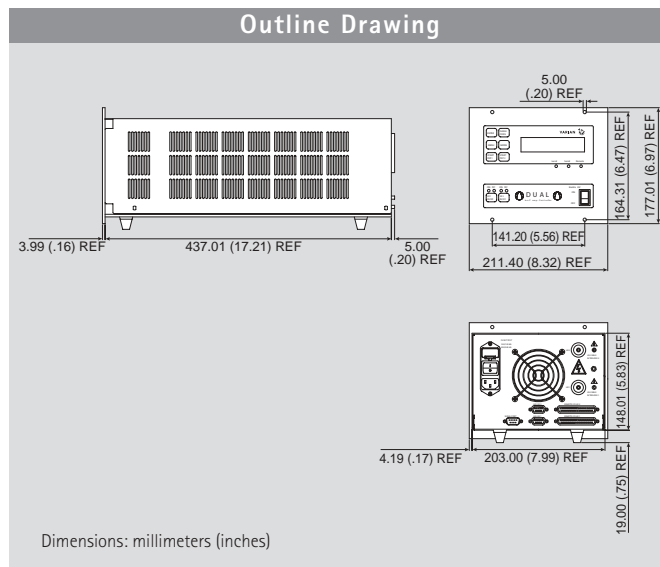

variable voltage feature allows optimum pumping speed and pressure readings in the whole operating pressure range. The unit features built-in set points, remote operation, and optional RS232 computer interface.

## Technical Specifications

### Input Voltage

90 to 130 VAC or 180 to 265 VAC not selectable

### Input Frequency

47 to 63 Hz

### Dimension

1/2 standard rack: H = 177 mm, W = 211.4 mm, D = 440 mm

### Display

16 characters, 2 lines LCD large display

### Minimum Configuration

1 HV Output, Set Point / Remote Control Card

### Maximum Configuration

2 HV Output, Set Point / Remote Control Card,  
1 Computer Interface, Eyesys Control Interface

### Output Voltage (Open Circuit)

Programmable between  $\pm 3000$  V and  $\pm 7000$  V not selectable

### Output Current (Short Circuit)

Programmable between 100 and 400 mA

### Power (Maximum)

Programmable between 100 and 400 W

### HV Connector

Fischer type 105

### Modes of Operation

Local/Remote, Start/Protect, Fixed/Variable Voltage

### Front Panel Readings

Output Voltage, Pressure (Pascal, mbar, Torr)  
Current (Minimum readable current 10 nA)

### Safety Marks

CE, cCSAus

### Conformity to Norms

EN 55011 Class A Group 1, EN 61000-3-3, EN 61000-4-2,  
EN 61000-4-3, EN 61000-4-4, EN 61010-1

### Output Recorder Signal

Analog,  $\varnothing$  to 5 VDC logarithmic proportional to pressure  
Analog,  $\varnothing$  to 7 VDC linear proportional to voltage

### Set Point / Remote Control Card Inputs

HV ON/OFF command and selection of operating mode  
(Start/Protect, Fixed/Step Voltage)

### Set Point / Remote Control Card Outputs

2 Set Point, High Voltage On, Interlock Ok, Fault, Remote Mode,  
Protect Mode and Voltage for the Remote Input

Diode, Noble Diode	positive
StarCell®, Triode	negative
(see page 40)	

\*For configurations with alternative computer interfaces please contact your local Varian representative.

# Dual Controller

## Dual Advantages

### Pressure Reading

The Dual unit is preprogrammed to automatically convert any Vaclon Plus pump current reading into pressure.

Thanks to its ability to detect ion current as low as 10 nA, and resolving increments as low as 10 nA, it allows pressure measurement in the  $10^{-10}$  mbar range. To ensure a reliable pressure reading (comparable to an ion gauge) down to the UHV region, the Dual optimizes the applied high voltage as a function of pressures. As a result, leakage current is minimized, thus providing more accurate pressure readings.

### Pumping Speed

The optimization of applied High Voltage in accordance with operating pressure, allows improved pumping speed performance. The optimization is based on the fact that the energy with which the ion bombards the cathode is the nominal applied High Voltage, reduced by the space charge effect due to the electron cloud present in the ion pump cell. Since the space charge effect is pressure related, a variable HV is applied to maintain an optimum bombardment energy, resulting in the best possible pumping performance at any pressure.

Typical Current vs Pressure Curve

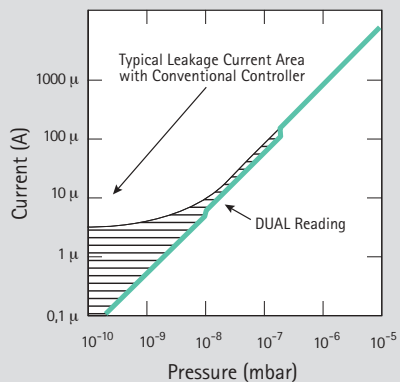

Pumping Speed vs Pressure at Different Voltages

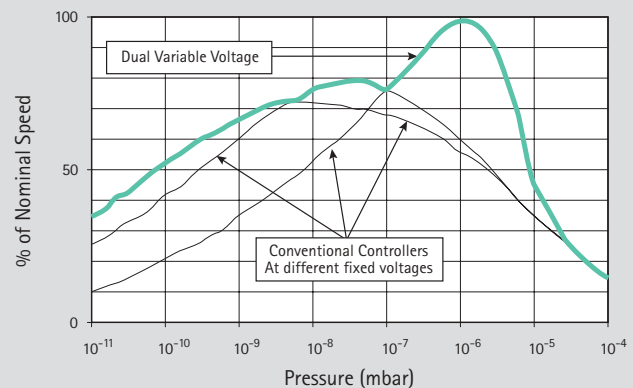

## Ordering Information

Description		Weight kg (lbs)	Part Number
<b>Dual Controller</b>			
One Pump Negative	120 V	10.0 (22.0)	9297000
Two Pumps Negative	120 V	11.5 (25.4)	9297001
One Pump Positive	120 V	10.0 (22.0)	9297002
Two Pumps Positive	120 V	11.5 (25.4)	9297003
One Pump Negative	220 V	10.0 (22.0)	9297004
Two Pumps Negative	220 V	11.5 (25.4)	9297005
One Pump Positive	220 V	10.0 (22.0)	9297006
Two Pumps Positive	220 V	11.5 (25.4)	9297007
One Pump Negative, with RS232 Interface	120 V	10.0 (22.0)	9297008
Two Pumps Negative, with RS232 Interface	120 V	11.5 (25.4)	9297009
One Pump Positive, with RS232 Interface	120 V	10.0 (22.0)	9297010
Two Pumps Positive, with RS232 Interface	120 V	11.5 (25.4)	9297011
One Pump Negative, with RS232 Interface	220 V	10.0 (22.0)	9297012
Two Pumps Negative, with RS232 Interface	220 V	11.5 (25.4)	9297013
One Pump Positive, with RS232 Interface	220 V	10.0 (22.0)	9297014
Two Pumps Positive, with RS232 Interface	220 V	11.5 (25.4)	9297015

Configurations with alternative computer interfaces and gauge control capability available on request.

### Accessories and Cables

Rack adapter 19"		9.1 (20.0)	9290064
HV bakeable cable, radiation resistant, 4 m (13 ft.) long, with Interlock		0.9 (2.0)	9290705
HV bakeable cable, radiation resistant, 7 m (23 ft.) long, with Interlock		1.6 (3.5)	9290707
HV bakeable cable, radiation resistant, 10 m (33 ft.) long, with Interlock		2.2 (5.0)	9290708
HV bakeable cable, radiation resistant, 20 m (66 ft.) long, with Interlock		4.4 (10.0)	9290709
Dual Profibus gateway		0.5 (1.0)	9297016

# MiniVac Controller



The MiniVac Ion Pump Controller is designed to economically operate any Vaclon *Plus* type and size: Diode, Noble Diode, and StarCell®, from Miniature to 500 l/s pumps. The MiniVac is very compact and light, and can be operated in a local or remote mode.

Medium pumps (Vaclon *Plus* 20 to 75) can be operated at any pressure below  $1 \times 10^{-5}$  mbar (continuous operation). Large pumps (Vaclon *Plus* 150 to 500) can be operated at any pressure below  $2 \times 10^{-6}$  mbar (continuous operation).

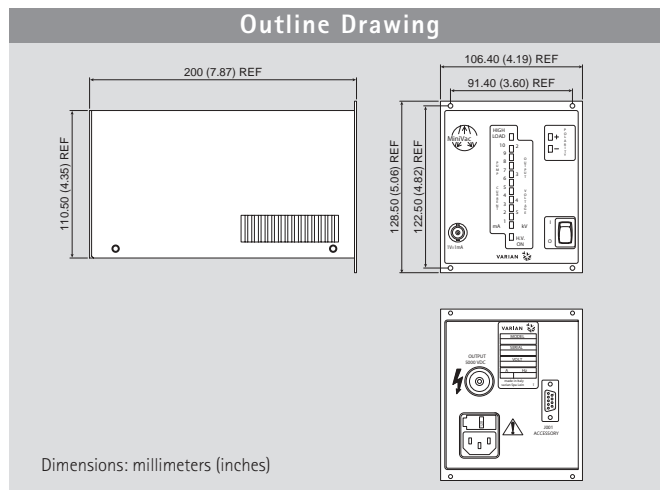

The MiniVac is designed to withstand continuous operation at short circuit conditions, without damaging the ion pump or itself. A 24 V battery-operable version is available for portable applications.

## Technical Specifications

### Input

90 to 130 VAC or 180 to 240 VAC or 24 VDC

### Output

Voltage:  $\pm 5000$  VDC (open load)

Current: 15 mA (short circuit)

Maximum Power: 21 W (3 kV at 7 mA)

### Front Panel

HV ON, HIGH LOAD, and POLARITY LEDs

LED bargraph linear scale for current and voltage indication

Recorder Output 0 to +10 VDC linear proportional to current (10 V = 10 mA)

### Safety Marks

CE, cCSAus

### Conformity to Norms

Safety: EN61010-1

EMI/EMC: EN61000-4-2, EN61000-4-3, EN61000-4-4

### Rear Panel

Nine pin "D" type connector with following available signals and commands Recorder outputs:

- 0 to +5 VDC, linear proportional to HV (1 V = 1 kV)
- 0 to +10 VDC, linear proportional to current (10 V = 10 mA)
- 0 to +10 VDC, linear proportional to current (10 V = 1 mA)

HV ON confirm signal: Contact rating – 1 A at 250 VAC; 0.2 A at 30 VDC

Remote HV ON/OFF (interlock) command

HV connector: Fischer type 105 or King type, 10 kV

## Ordering Information

Description		Weight kg (lbs)	Part Number
<b>MiniVac Controller</b>			
With any Vaclon <i>Plus</i> pump	MiniVac, FISCHER HV connector, US plug, 120 V preset	2.3 (5.0)	9290191
	MiniVac, FISCHER HV connector, European plug, 220 V preset	2.3 (5.0)	9290290
	MiniVac, FISCHER HV connector, 24 VDC	2.3 (5.0)	9290196
With small Vaclon pumps (2 and 8 l/s)	MiniVac, KING HV connector, US plug, 120 V preset	2.3 (5.0)	9290190
	MiniVac, KING HV connector, European plug, 220 V preset	2.3 (5.0)	9290291
	MiniVac, KING HV connector, 24 VDC	2.3 (5.0)	9290197
<b>Accessories and Cables</b>			
With any Vaclon <i>Plus</i> pump	19" Rack adapter	4.5 (10.0)	9699191
	HV bakeable cable, radiation resistant, 4 m (13 ft.) long, with Interlock	0.9 (2.0)	9290705
	HV bakeable cable, radiation resistant, 7 m (23 ft.) long, with Interlock	1.6 (3.5)	9290707
	HV bakeable cable, radiation resistant, 10 m (33 ft.) long, with Interlock	2.2 (5.0)	9290708
With small Vaclon pumps (2 and 8 l/s)	HV bakeable cable, radiation resistant, 20 m (66 ft.) long, with Interlock	4.4 (10.0)	9290709
	HV bakeable cable, radiation resistant, 4 m (13 ft.) long, with Interlock for 2 l/s pump	0.9 (2.0)	9290706
	HV cable, 3 m (10 ft.) long, for 8 l/s Vaclon pumps	0.9 (2.0)	9240741

Diode, Noble Diode	positive	
StarCell®, Triode	negative	(see page 40)

# Miniature and Small Vaclon Pumps and Controllers

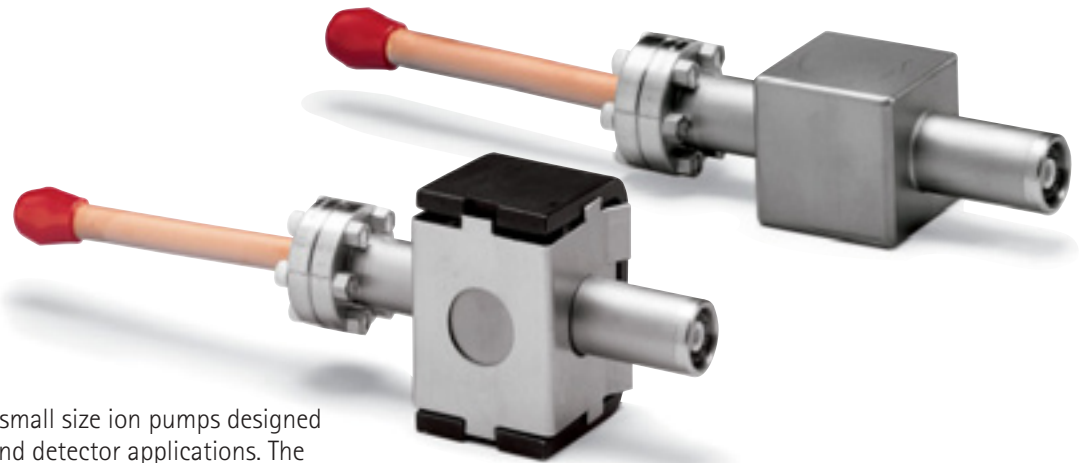

Varian offers a wide variety of small size ion pumps designed especially for electron device and detector applications. The Miniature Vaclon pump is a diode configuration and provides approximately 0.4 l/s of nitrogen pumping speed. The 2 l/s model is a modified diode configuration to enhance starting at low pressure. The 8 l/s pump is a diode configuration with high efficiency for residual gases such as hydrogen. Pumps that are processed are baked to 400° C and pinched off under vacuum, which allows the vacuum integrity to be verified by the user just before use. Non-processed pumps are tested for no vacuum leaks and minimum leakage current.

### Modified and Customized Versions

Modified versions of standard pumps can be provided when different inlet tube lengths, angles, and diameters are required. These pumps can also be customized with different high voltage feedthroughs, body geometries, and pumping cell arrangements. Special testing procedures can be quoted for customers who have specific requirements in this area.

### Ordering Information

See page 33 for controllers, cables, and accessories.

Description	Weight kg (lbs)	Part Number
<b>Miniature Pump</b>		
With 3/8" OD 180° stainless steel tube	0.5 (1.0)	9130038
With 3/8" OD 90° stainless steel tube	0.5 (1.0)	9130041
With 3/8" OD 180° copper tube, vacuum processed	0.5 (1.0)	9130049
With 3/8" OD 90° copper tube, vacuum processed	0.5 (1.0)	9130050
Magnet for Miniature pump	0.5 (1.0)	9130042
HV cable, 2.4 m (8 ft.) long, for Mini Vaclon pumps	0.9 (2.0)	9240122
<b>2 l/s Pump</b>		
With 3/4" OD 180° stainless steel tube	0.9 (2.0)	9190521
With 3/4" OD 180° copper tube, vacuum processed	0.9 (2.0)	9190522
With 3/4" OD 180° stainless steel tube, vacuum processed	0.9 (2.0)	9190523
With 3/4" OD 90° stainless steel tube, tee style	0.9 (2.0)	9190524
With 1 1/3" CFF 180° vacuum processed	0.9 (2.0)	9190520
Magnet for 2 l/s pump	0.9 (2.0)	9190038
HV bakeable cable, radiation resistant, 4 m (13 ft.) long with interlock for 2 l/s pump	0.9 (2.0)	9290706
<b>8 l/s Pump</b>		
8 l/s Vaclon pump, processed, with 2 3/4" CFF	3.6 (8.0)	9115005
Magnet assembly for 8 l/s Vaclon pump	5.0 (11.0)	9110030
HV cable, 3 m (10 ft.) long, for 8 l/s Vaclon pumps	0.9 (2.0)	9240741

Magnets must be ordered separately.

Outline Drawing

Miniature Pump (90 deg. config.)

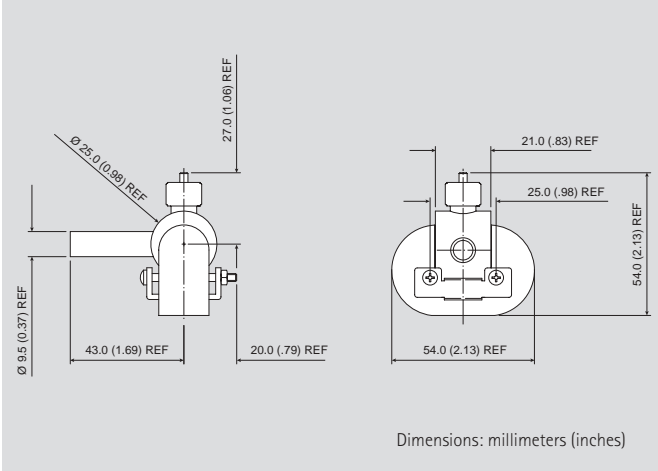

Miniature Pump (180 deg. config.)

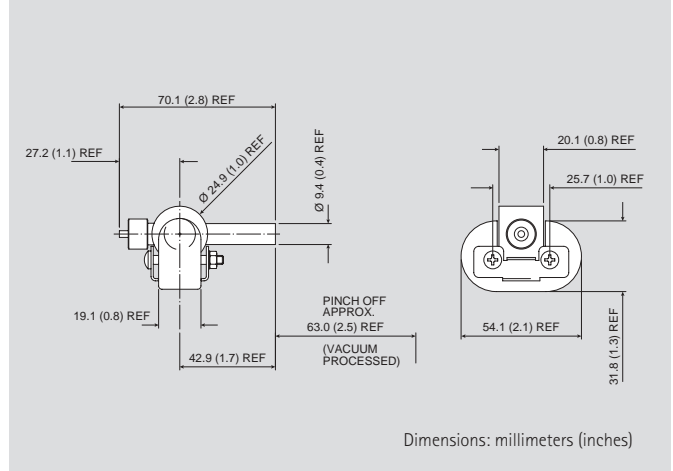

2 I/s Pump

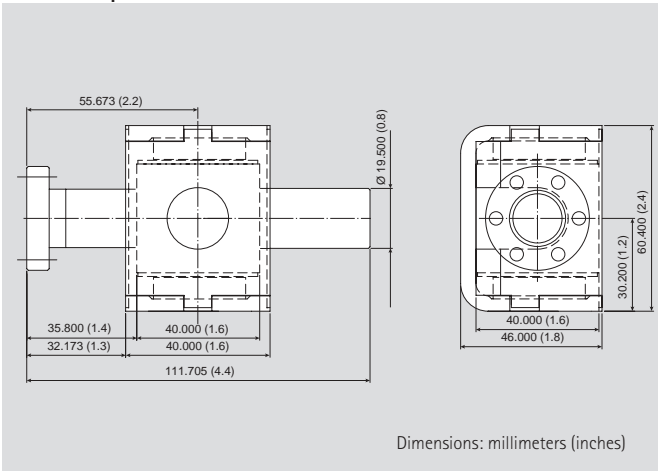

8 I/s Pump

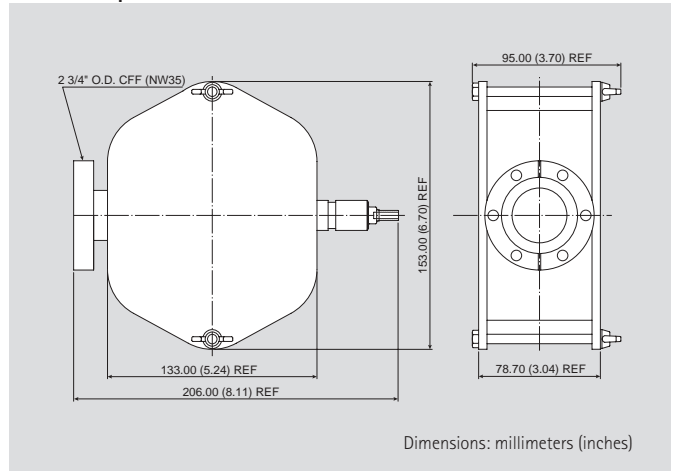

The Miniature and 2 I/s pumps are available with copper or stainless steel inlet tubes in 90- or 180-degree configurations, relative to the high voltage feedthrough.



# Titanium Sublimation Pumps and Controllers

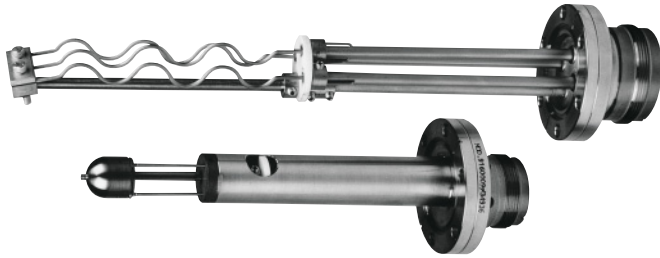

Titanium sublimation pumps (TSPs) are typically used as an effective way to pump getterable gases such as hydrogen and nitrogen in UHV systems. TSPs are often combined with ion pumping, since the ion pump is effective with non-getterable UHV gases such as argon and methane. The TSP can be added to the inside of the ion pump, or as a separate pumping unit. If the TSP is used in conjunction with a liquid nitrogen-cooled cryopanel, extra high water pumping speed will be achieved. Varian offers two different types of titanium sublimation pumps: filament and titanium ball sources. Filament-type TSP sources are most popular with UHV systems since they can be turned off between sublimations and thus do not add thermally-induced outgassing. The ball-type sources contain larger amounts of titanium which means longer life when operated under conditions that use more titanium, such as higher operating pressures. However, the ball sources require standby power between sublimations to prevent cracks from forming in the titanium ball. The factors affecting titanium sublimation pumping efficiency include sublimation rate, frequency, surface area, and temperature. Sublimation pumping speed is generally a constant value below  $10^{-7}$  mbar.

## Outline Drawing

### TSP Cartridge

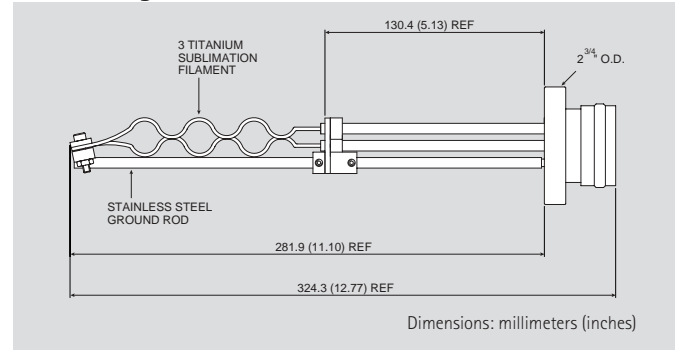

### TSP Cartridge Filament Source

The popular TSP cartridge is provided on a 2 3/4" OD ConFlat® flange and contains three titanium-molybdenum filaments, each with 1.1 grams of usable titanium. The cartridge assembly is bakeable to 400° C. Maximum sublimation is achieved at 300 watts of source power.

## Technical Specifications

Usable Titanium (per filament)	1.1 grams
Total Usable	3.3 grams
Operating Range	$10^{-4}$ to $10^{-12}$ mbar

## Outline Drawing

### Mini Ti-Ball

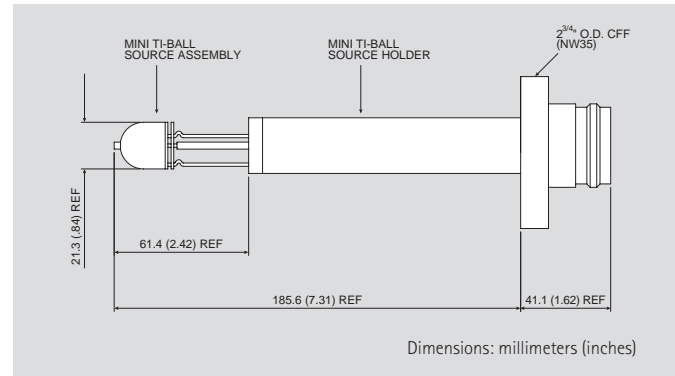

### Mini Ti-Ball Source

The Mini Ti-Ball source provides 15.2 grams of usable titanium and is mounted on a 2 3/4" OD ConFlat® flange. Maximum sublimation is achieved at 300 watts of source power, while the Standby power requirement is 100 watts.

## Technical Specifications

Usable Titanium	15.2 grams
Operating Range	$10^{-4}$ to $10^{-12}$ mbar

# TSP Cryopanel

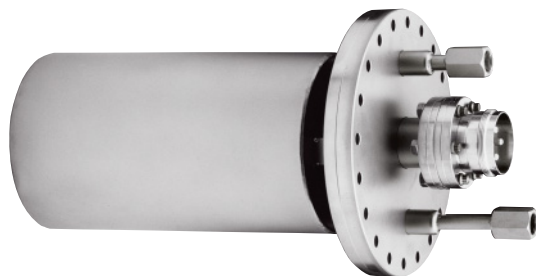

## TSP Cryopanel

Designed for use with the TSP cartridge source\*, this sublimation cryopanel is mounted to an 8" OD ConFlat® flange. It can operate with water cooling, liquid nitrogen, or uncooled if used at UHV. This cryopanel can be mounted to double-ended or side-ported ion pumps and can also be used independently in any 8" (NW 150) CFF port with 11 inch depth/clearance.

*The Cryopanel does not include the cartridge.*

### Technical Specifications

	N <sub>2</sub>	H <sub>2</sub>	H <sub>2</sub> O
Pumping speed at 20 °C water-cooled (l/s)	515	1200	575
Inner pumping surface (cm <sup>2</sup> )	826		
Main flange	8" CF (NW150)		
Reservoir volume (liters)	1.8		
Cooling connection	3/8" G		
Titanium source flange	2 3/4" CF		

### Outline Drawing

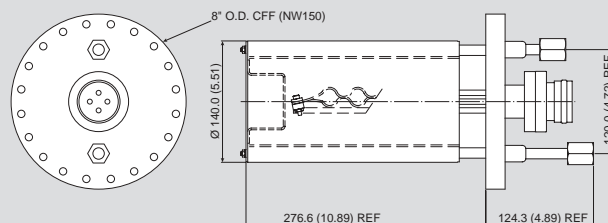

Dimensions: millimeters (inches)

### Pumping Speed vs Pressure at different evaporation rates

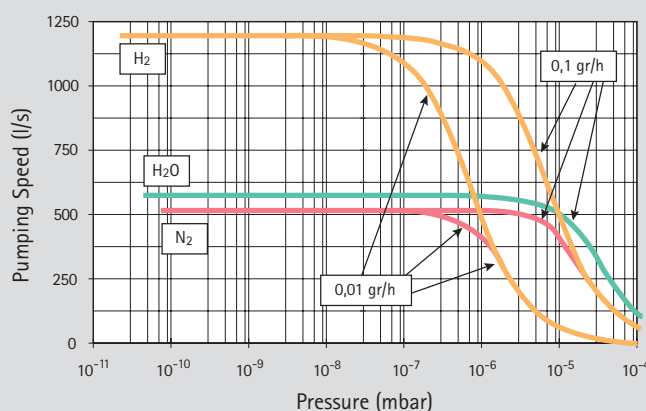

Ion Pumps

# TSP Controller

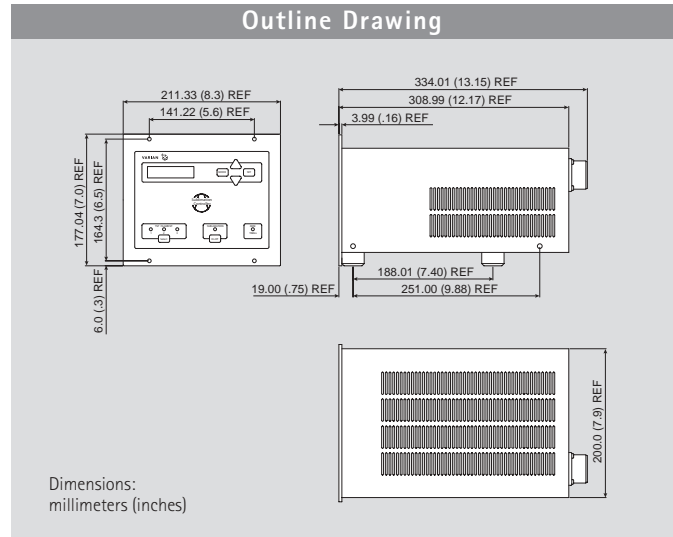

## Features

- Compact design 1/2 standard rack
- Selectable for automatic or manual operation
- Remote control optional via RS232/422/485
- To operate TSP filament cartridge (9160050) or Mini Ti-Ball (9160009)
- Safety Marks: CE, cCSAus

## Technical Specifications

### TSP Cartridge and Mini Ti-Ball – Conventional

Input Power	90 – 130 VAC 180 – 265 VAC 1 phase 50/60 Hz
Output Current	0 to 50A
Output Power	500 W maximum
Operating Mode	Automatic or manual. Programmable sublimation current, run time, and start time.
Power Cable	3 meters
Cables (order separately)	9240730 for TSP filament (9160050) 9240752 for mini Ti-Ball (9160009)

## Ordering Information

Description	Weight kg (lbs)	Part Number
<b>Titanium Sublimation Pumps</b>		
TSP Filament Cartridge on a 2 3/4" CFF	2.7 (6.0)	9160050
Replacement filaments, package of 12 each	0.9 (2.0)	9160051
Mini Ti-Ball Source with Holder on a 2 3/4" CFF	2.3 (5.0)	9160009
Replacement Mini Ti-Ball Source	0.5 (1.0)	9160008
<b>Controllers</b>		
TSP cartridge and Mini Ti-Ball Control unit – 120V (Order cables separately)	17.7 (39.0)	9290022
TSP cartridge and Mini Ti-Ball Control unit – 220V (Order cables separately)	17.7 (39.0)	9290023
RS232 Computer Interface	0.5 (1.0)	9290024
RS422 Computer Interface	0.5 (1.0)	9290025
RS485 Computer Interface	0.5 (1.0)	9290026
Rack Adapter 19"	9.0 (20.0)	9290064
<b>Cables</b>		
3.5 m (12 ft.) TSP Cartridge cable	9.1 (20.0)	9240730
3.5 m (12 ft.) Mini Ti-Ball Cable	6.8 (15.0)	9240752
<b>Titanium Sublimation Cryopanel</b>		
Sublimation Cryopanel on an 8" CFF	10.4 (23.0)	9190180

# Ion Pump Technical Notes

## Historical Notes

Ion pumping is used to remove gases from systems in order to create ultra-high vacuum environments. The earliest evidence of ion pumping was reported by J. Plucker (1858 - Germany) who found that it took ever-increasing voltages to maintain a current in a gas discharge tube.

This, he rightly concluded, is due to a reduction of pressure in the tube by some mechanism involving the cathode.

Later, as an offshoot of his work on electrical discharge in gases, F. Penning (1937 - Holland) developed a cold cathode ionization gauge for measuring pressures in the range of  $10^{-3}$  to  $10^{-5}$  Torr. Due to the sputtering effect of the high voltage, ions were both buried in and "gettered" by the cathode material. (Gettering is the chemical combination of active gases with a suitably reactive substance).

The result of this pumping action was a noticeable pressure reduction. The Penning cell has been used as a commercially available vacuum gauge ever since, but it was not until the late 1950's that its pumping characteristics were exploited by Varian Associates, resulting in the invention of the ion pump. This was done in order to improve the life and performance of microwave tubes by continuous pumping with "appendage" ion pumps.

The invention of the sputter ion pump ushered in the era of ultrahigh vacuum, just in time to make a large contribution to the space age.

The availability of vacuum systems that could routinely achieve pressures in the low  $10^{-11}$  Torr range enhanced R&D efforts. Space hardware and space-compatible materials were tested by simulating many of the conditions they would encounter. Today, ion pumps are used in both research and industrial applications wherever a pristine, oil-free, vibration-free, cost-effective environment is required.

## Operation

Vacuum pumps in general operate on the basis of maintaining a lower gas density within themselves than exists in the environment they are pumping. This results in a net gas migration into the pump due to the random motion of the molecules under molecular flow conditions. Once in the pumps, few escape and they are either displaced or captured, depending on the type of pump.

Rather than being a displacement pump that actually moves molecules of gas through it to the atmosphere, the ion pump instead captures and stores them. As a result, at some point in time the pump must be reconditioned or replaced. This is generally required only after many years of use.

The generic name Sputter Ion Pump (or Ion Getter Pump) comes from the fact that some of the gas molecules undergo ionization and cause sputtering of the gettering agent. This material chemically reacts with the active gases to form

stable compounds that are deposited on the internal walls of the pump. The getter, usually titanium, is provided by a plate or electrode of that material, which is in turn sputtered and eroded by gas ions formed under the influence of the high voltage. These electrical potentials are usually in the range of 3,000 to 7,000 Vdc.

Most ionization devices operate in the same way. Gas molecules are bombarded by high energy electrons when a collision occurs. A molecule may lose one or more of its own electrons and thereby is left as a positively charged ion. Under the influence of a strong electric field, the ion is accelerated into the titanium cathode. The force of this collision is sufficient to cause atoms to be ejected from the cathode and "sputtered" onto the adjacent walls of the pump. Freshly sputtered titanium is extremely reactive and will chemically react with active gases. The resulting compounds accumulate on surfaces of the pump elements and pump walls.

Active gases are those such as oxygen, nitrogen, CO, CO<sub>2</sub>, and water, as opposed to the noble gases like helium, neon, argon, krypton, and xenon, which are nonreactive. The latter are pumped by "ion burial" (ion burial is the "plastering over" of inert gas atoms by the sputtered getter atoms).

The simplest form of ion pump is the Penning cell, which was originally conceived as a cold cathode vacuum gauge. It consists of a central anode wire which is at positive high voltage. In an ion pump the anode can either be a short section of metal tubing or a square, box-like structure, open at each end like a unit of an egg crate. Opposite each open end is a plate of titanium that is connected to the ground to form the cathode structure. An external permanent magnetic circuit generates a magnetic field, usually ranging from 800 to 2,000 G, parallel to the anode cell axis. A cell configured in this way is said to be a diode pump (Figure 1). It is then packaged in a suitable enclosure and the assembly becomes a pump.

To make a higher speed pump, it is now simply a matter of making a package containing more cells with a larger cathode (Figure 2).

The function of the anode cell structure is to contain a "cloud" of high energy electrons which are constrained by the magnetic field.

This field causes the electrons to move in oscillating spiral paths (Figure 3) that increase their chances of striking gas molecules and thereby create positive ions. These ions are accelerated away from the positive anode voltage and collide into the titanium cathode plates (Figure 3). This results in the removal of titanium atoms by "sputtering".

The sputtered titanium is deposited on the internal surfaces of the pump where it reacts with absorbed active gases to form stable compounds.

In summary, the pumping efficiency depends on the electron "cloud" density (which determines the number of ions produced) and on the sputtering yield (which determines the quantity of active getter material produced).

# Ion Pump Technical Notes

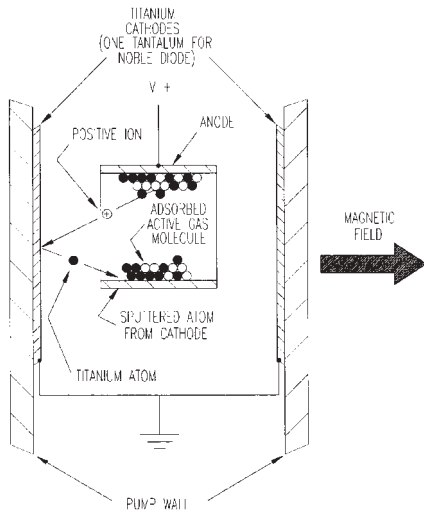

Figure 1



Ion pump cutaway

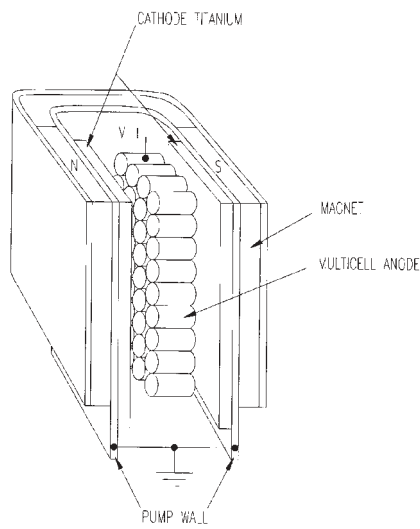

Figure 2

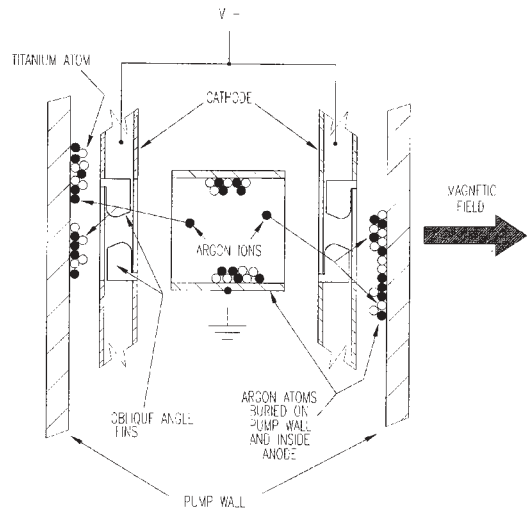

Figure 4

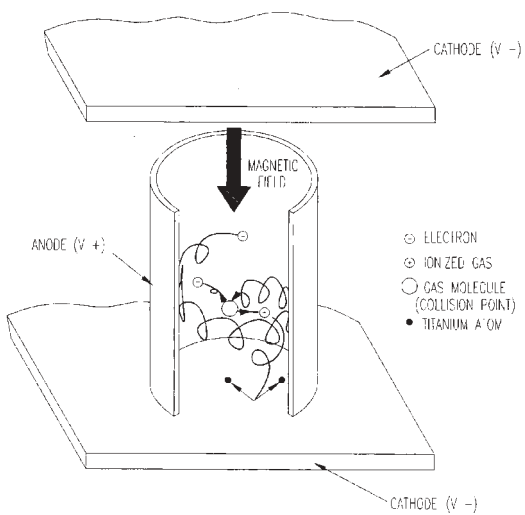

Figure 3

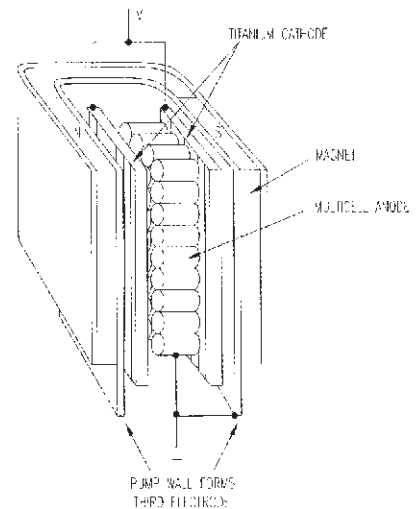

Figure 5

The electron cloud density mainly depends on the Penning cell geometry and on the electric and magnetic field strengths. By adjusting these parameters, the pump performance can be modified according to the application. In particular, using an "intelligent" high voltage power supply, the right voltage can be automatically selected as the pressure changes.

The sputtering efficiency depends on the cathode geometry and material and on the gas species. Thus the cathode configuration can also be optimized for the gas used in the application.

Varian offers three different cathode configurations that will satisfy a wide variety of applications involving different gases and operative pressures.

It should be noted that a few types of gases do not need to be ionized in order to be pumped. Hydrogen, for instance, reacts directly with the titanium cathode plates as well as the sputtered film.

It is the function of the ions to maintain a fresh supply of "gettering" material. In this regard, the ion pump is self-regulating; it only sputters as much getter material as is needed at that particular pressure.

In this way, at low pressures cathode plates are not wasted and electric power is conserved.

Some of the noble gas atoms are pumped as a result of being ionized.

In this case, they are implanted (at least temporarily) in the cathodes by the force of the accelerating voltage. Others are pumped by burial in the sputtered titanium film (Figure 4). Generally, pumping noble gases does not pose a problem because they are present in such small quantities. When it is necessary to deal with considerable amounts of noble gases, a pump of the triode configuration should be used (Figure 5).

In the triode pump, the cathode is at negative potential and built with slits that permit grazing incidence sputtering. Thus, they tend not to be implanted to any appreciable extent and the un-sputtering of previously buried noble gases is largely eliminated. Instead, the gases either react with or are buried by the sputtered film on the walls of the pump body and on the anode.

## Selecting Vaclon Plus Pumps

Ion pumps are commonly used to create Ultra High Vacuum (UHV), due to their cleanliness, ability to pump different gases, and maintenance- and vibration-free operation. Long operating life and ability to read pressure are other important features of ion pumps.

The Vaclon Plus family has been designed to enhance all of these characteristics, and thus offers the most advanced and valuable solution to any ion pumping requirement.

## Cleanliness

To reach very low pressures (i.e.  $10^{-11}$  mbar) in any system, both the chamber and pump outgassing must be minimized. If not cleaned properly, the ion pump itself can be a source of gas at UHV.

In order to ensure cleanliness, Vaclon Plus Pumps are factory processed at high temperature in ultraclean vacuum for a thorough outgassing of the body and all internal components.

The cleanliness of the ion pump element is even more critical, due to the continuous cathode bombardment. Any gas trapped on the surface or in the bulk of the cathode will eventually be released.

## Ion Pump Outgassing System

The ion pump outgassing system is a thermal process of the pump body, completely computer controlled and able to provide an automatic final test of the achieved pump specifications.

The bake-out of the pump is done in a nitrogen-controlled atmosphere to protect the external pump body from oxidation. See Figure 6 for System outline.

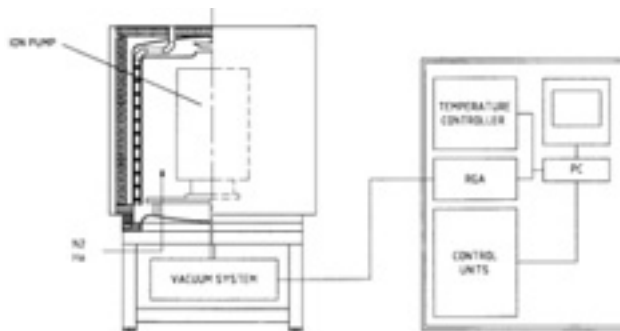

Figure 6 - System outline

The system is based on the principle of thermal outgassing the ion pump internal surfaces through the control of the their intrinsic outgassing. Therefore pressure, not time, is the driving factor of the overall process.

The bake-out time depends on the internal cleaning of the pump components and all the pumps will have, in this way, the same final outgassing rate and base pressure.

Figure 7 shows the working principle. The green curve represents the temperature and the yellow one the pressure read by the gauge located on the vacuum control system placed on the bottom of the outgassing station (see Fig. 6). The temperature is maintained at the set point level until the pressure does not change any more, which means the outgassing of the pump for the defined bake-out temperature is completed.

# Ion Pump Technical Notes

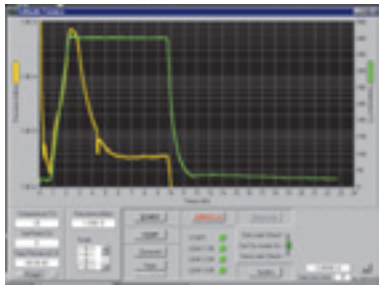

Figure 7 - Thermal process working principle

At the end of the thermal process, once room temperature is achieved, an RGA is performed. The gas analyser, placed on the vacuum system, provides the spectrum of the different gases degassed by the pump. If H<sub>2</sub> and the other peaks normally present in a well-baked vacuum system exceed the acceptance levels, the pump is baked again. Otherwise, it is pinched off and its base pressure monitored. The base pressure is evaluated through the ion current reading.

The current decrease is computer monitored, and the pump is ready to be shipped only after the base current is reached. Figure 8 shows the result of the residual gas analysis performed at the end of the bake-out.

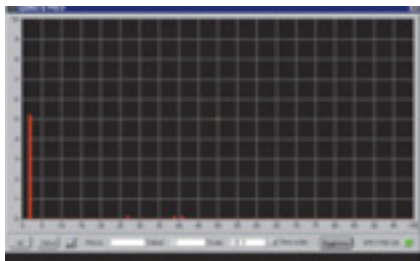

Figure 8 - Residual gas analysis

## Pumping of Different Gases

In general, all ion pumps can pump all gases to some degree. To obtain the best performance and base pressure, different types of ion pumps have been developed with optimized performance in different pressure ranges and with different gases.

Varian's Vaclon *Plus* is a complete product family that offers the choice among three different elements: Diode, Noble Diode and StarCell®.

Whatever the application, there is a Vaclon *Plus* pump designed for it.

## Long Operating Life

All Vaclon *Plus* pumps have rated lives in excess of many thousand of hours at a pressure of  $1 \times 10^{-6}$  mbar (50,000 hours for the Diode pump, and 80,000 hours for the StarCell®).

With many ion pumps, maintenance may be required well before the rated life, due to metallization of insulators or pumping element distortion.

All Vaclon *Plus* elements are designed to minimize cathode distortion (even after repetitive bake-outs and starting at high pressure), and the insulators are protected from sputtered titanium by using a double re-entrant design and a cap shield.

## Pressure Reading

The ability to read pressures using an ion pump is due to the direct proportionality between pump current and operating pressure.

The reliability of pressure readings at very low pressure is limited by leakage current, and the leakage current from field emission is heavily dependent on the voltage applied to the pump.

The Dual controller, designed for use with any Vaclon *Plus* pump, provides the unique ability to adjust the voltage in accordance with the operating pressure. By doing this, the leakage current is minimized at low pressure, providing a reliable pressure reading down to the  $10^{-10}$  mbar range.

## Custom Design and Flexibility

All ion pumps can be mounted in any position, and do not need any isolation valve from the system in case of venting or power failure.

Vaclon *Plus* pumps are the most compact ion pumps in each speed range. The pumps can be configured with additional flanges and can accommodate other pumping systems (like TSP), allowing the best use of available space.

## New Feedthrough

The whole Ion Pump line is provided with an innovative feedthrough.

The improved feedthrough of the ion pump line is a major breakthrough. The greatest advantages of the ion pumps are listed here below:

- **Corrosion Free**

The design of the feedthrough will reduce drastically the corrosion that may occur when the pump is used in humid environments.

Our tests and experience have demonstrated that the corrosion starts and increases with the presence of humidity between feedthrough and connector. The high voltage during the pump operation ionizes the entrapped water vapor; the ions react with the brazing alloy and corrode it. The design of the feedthrough aims to solve these issues:

- On one hand the design structure of the feedthrough presents a negligible quantity of air.
- On the other hand, the brazing is done on the vacuum side so that the brazing alloy surface exposed to air is minimal.

- **High Voltage Cable Interlock**

The feedthrough has been designed for the "HV cable safety

interlock" implementation. This feature avoids any electrical shock since the voltage is automatically cut off as soon as the cable is disconnected from the pump.

Our Ion Pump control unit (Dual) and the HV cable are already able to support this safety feature when connected to an ion pump with the feedthrough.

- **Easy Connection**

The connection of the cable connector to the feedthrough requires simply inserting and pushing the connector. No use of retention screws is required.

- **Safety against Unintentional Extraction**

When the HV cable connector is inserted into the new patented feedthrough, it is firmly and mechanically secured to it. A latch on the cable prevents disconnection.

- **Compactness**

The feedthrough design allows a significant gain of space for the customer.

## The Vaclon *Plus* Family

### Diode Vaclon *Plus*

The diode version of the Vaclon *Plus* pump has the highest pumping speed among all ion pumps for oxygen (O<sub>2</sub>), nitrogen (N<sub>2</sub>), carbon dioxide (CO<sub>2</sub>), carbon monoxide (CO), and any other getterable gas. It provides the highest pumping speed and capacity for hydrogen (H<sub>2</sub>) as well.

Its simple mechanical structure allows a reliable current/pressure reading down to very low pressures, as well as absolutely vibration-free operation. Its geometric and electrical configuration allows it to be used in the vicinity of electron detectors or similar devices.

Diode Vaclon *Plus* pumps are therefore widely and successfully used in general purpose UHV systems, for evacuating electron devices and in the most sensitive electron microscopes. However, diodes are not suggested for applications where noble gases such as argon (Ar), helium (He), and methane (CH<sub>4</sub>) are to be pumped.

### Noble Diode Vaclon *Plus*

The Noble Diode Vaclon *Plus* element is a version of the diode element, in which a tantalum cathode is substituted in place of a titanium cathode. This substitution allows a higher pumping speed and stability for pumping noble gases (mainly argon and helium).

The element is otherwise equivalent to the Diode Vaclon *Plus*.

Noble Diode Vaclon *Plus* pumps are used in any application where pumping of noble gases is an important characteristic. As with the diode configuration, the Noble Diode retains a consistent pumping speed for all gases at very low pressures. However, pumping speed for H<sub>2</sub> and getterable gases is lower than for the corresponding Diode. The Noble Diode Vaclon *Plus* is typically used in UHV applications where a mixture of gas is to be pumped and where the pressure is quite constant

(i.e., no sudden gas burst or systematic high pressure cycling).

Its characteristics of consistent speed for almost any gas even at very low pressures make it ideal whenever the ion pump alone is used to obtain UHV pressures. This is often the situation in particle accelerators or synchrotron rings, as well as in surface analysis applications.

Other Vaclon *Plus* versions are suggested whenever the application requires cycling to higher pressures, pumping of large amounts of H<sub>2</sub>, or when the ion pump is combined with other UHV pumps such as Titanium Sublimation Pumps or Non-Evaporable Getters.

### StarCell® Vaclon *Plus*

The StarCell® Vaclon *Plus* element is the latest variation of the Triode configuration. Its patented design makes this ion pump the only one that can handle a high amount of noble gases (better than Noble Diode) and hydrogen (comparable to the Diode). Furthermore, this pump provides the highest speed and capacity for methane, argon, and helium. Its high total capacity for all the different gases, together with its very good speed performance at relatively higher pressures, makes the StarCell Vaclon *Plus* ideal for applications requiring constant operation at 10<sup>-8</sup> mbar or above. This typically includes Electron Microscopes and Mass Spectrometers.

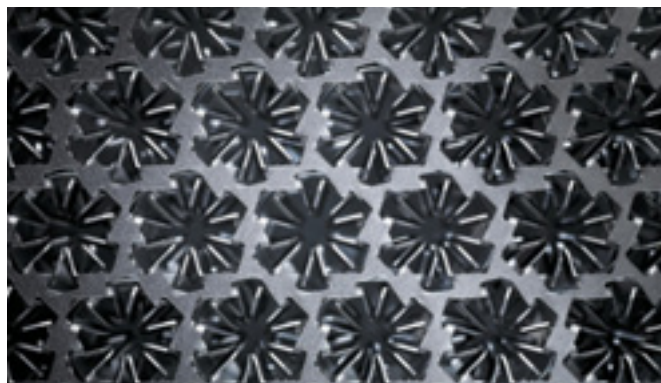

Figure 9 - StarCell pumping element

Its high pumping speed for argon, helium, and methane (the highest of any ion pump at any pressure) has made StarCell® the standard for any application where the ion pump is used in combination with TSP or NEG pumps, where its pumping performance is enhanced. The lowest attainable pressure has been obtained with combinations of StarCell® Vaclon *Plus* and TSP/NEG pumps, thanks to the optimized characteristics of these combinations. Most existing particle accelerators and synchrotron sources, beam lines, transfer lines, and similar devices have used and are successfully using these combinations to obtain the maximum speed for all the gas species.

For more specific information regarding the pumping speeds for different element configurations relevant to different

# Ion Pump Technical Notes

gases, refer to the various curves published in the Vaclon *Plus* Pumping Speed section. The aim of this section is to help you choose the best Vaclon *Plus* configuration. Whatever the application, there is a Vaclon *Plus* version suited for it.

Do not hesitate to contact your local Varian representative if you need more assistance in making the right choice.

*For Vaclon Plus and NEG integrated pumps, please ask Varian for a special quotation.*

## Vaclon *Plus* Pumping Speed

The most common parameter used to express the capability of a pump to remove molecules from a given volume is pumping speed. It is usually measured in liters per second and expresses the volume of gas (at a given pressure) removed per time unit.

In an ion pump, the net pumping effect results from the sum of different phenomena:

- The pumping action of the getter film produced by the sputtering of cathode material by ion bombardment.
- The pumping action due to the ion implantation and diffusion into the cathode.
- Gas burial on the anodes and pump walls.
- The gas re-emission from the cathode due to cathode heating and erosion.

When an ion pump is new or has been regenerated, for example by baking, the surface layer of the cathode is clean and the gas re-emission from it is negligible. In this condition, the ion pump is called "unsaturated" and the pumping effect is due both to the gettering effect as well as to ion implantation and diffusion. As the number of gas molecules implanted into the cathode increases, the re-emission of them due to the ion bombardment increases.

As a consequence, the net pumping speed decreases until an equilibrium condition between ion implantation and gas re-emission is reached. In this condition, the ion pump is "saturated" and the net pumping speed, due only to the gettering action of the material sputtered from the cathode, is about half the pumping speed of the unsaturated pump.

Since the saturation effect depends on the quantity of gas molecules implanted into the cathode, the time required to saturate an ion pump is inversely proportional to the pressure at which the pump is operated. Thus, the lower the pressure, the longer the time before the pump saturation occurs (Figure 10).

In an ion pumped UHV system with a proper bakeout procedure (and consequent pump regeneration), a pressure in the  $10^{-11}$  mbar range is possible. At this pressure, the ion pump will work at the higher (unsaturated) pumping speed values for a few years before it is saturated.

When pump saturation is reached, the pumping speed is

constant and no longer depends on the quantity of pumped gas. The values of the pumping speed curve after saturation are the lowest obtainable at any given pressure.

Generally, the ion pump works in an intermediate condition between the unsaturated and saturated extremes. The "nominal" pumping speed is defined as the maximum point on the pumping speed curve for a saturated pump; the reference gas is usually nitrogen.

The nominal pumping speed thus defines only a part of the characteristics of an ion pump. A more comprehensive description of an ion pump performance is given by the complete pumping speed vs pressure curve. By using these plots and keeping in mind the application, the best pump can be chosen.

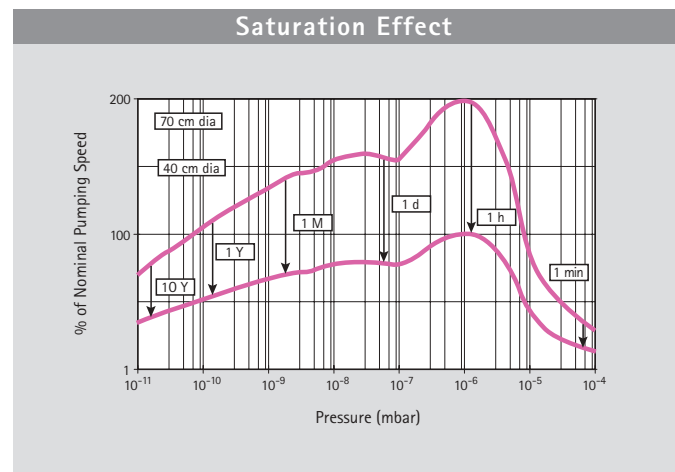

Figure 10

## Active Gases ( $N_2$ , $O_2$ , CO, $CO_2$ ,...)

A characteristic of these gases is their ability to easily react with most metals forming stable compounds. In an ion pump, these active gas molecules react with the fresh titanium film produced by the sputtering of the cathode material. These active gas molecules do not diffuse deeply in the cathode. The saturation effect, due to the re-emission of these molecules trapped on the cathode surface, is very strong.

Diode and Noble Diode elements show a higher pumping speed at low pressure while StarCell® elements perform better at higher pressure, because the Penning discharge is better confined inside the element (Figures 11, 12).

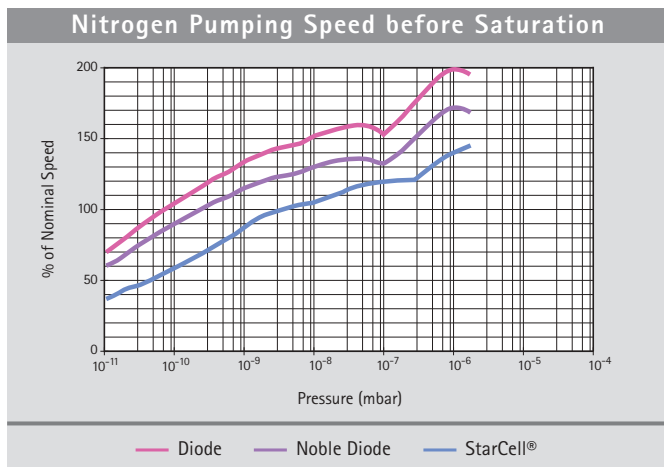

Figure 11

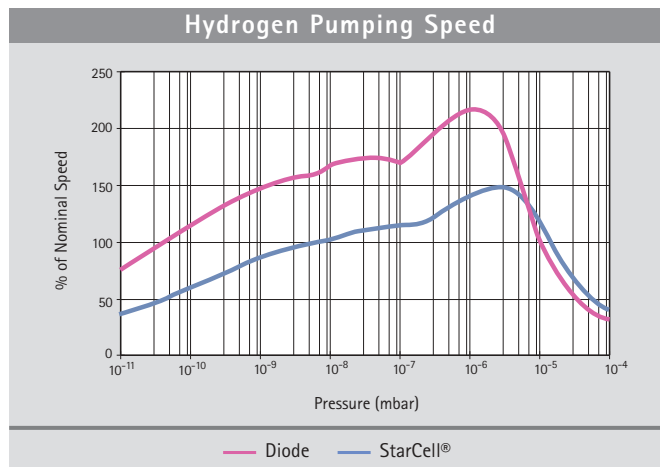

Figure 13

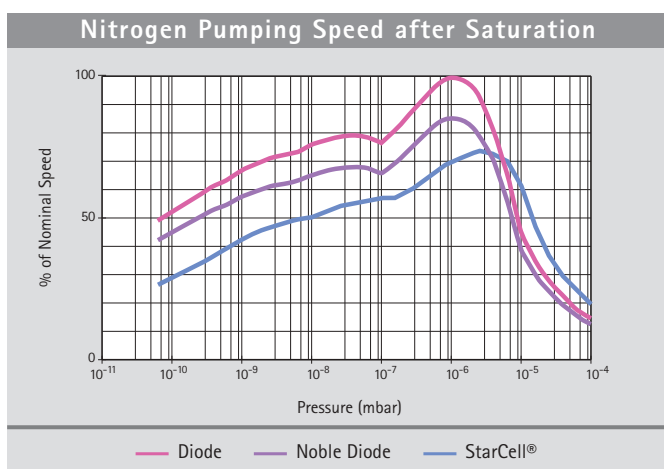

Figure 12

### Hydrogen

Hydrogen is an active gas but, due to its very small mass, the sputtering rate is very low. In spite of this fact, the pumping speed for H<sub>2</sub> is very high because it quickly diffuses into the cathode with negligible re-emission. When pumping H<sub>2</sub>, the ion pump always works in the unsaturated condition. As a result, the nominal speed for H<sub>2</sub> is about twice the corresponding value for nitrogen. Furthermore, if some traces of heavier gases are present, the increased sputtering rate produces an even higher hydrogen pumping speed.

The Diode element shows a higher pumping speed than the Noble Diode since the H<sub>2</sub> solubility in the tantalum cathode is lower than in a titanium cathode. StarCell® elements combine good performance at higher pressures with enhanced capacity for H<sub>2</sub>.

### Noble Gases (He, Ne, Ar,...)

The main characteristic of noble gases is that they do not react with any other element. Therefore, the film produced by the sputtering of cathode material does not provide getter pumping for helium and argon. Moreover, since these gases do not tend to diffuse into the cathode, the pumping effect due to the ion implantation is not permanent. Nevertheless, all the ion pump elements have some capacity to remove these gases.

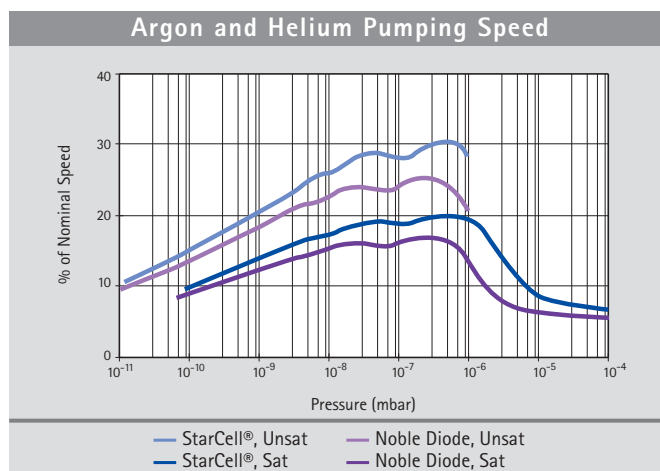

Figure 14

Noble gases are pumped by being buried by titanium. Noble gas ions can be neutralized and scattered from the cathode without losing their energy. These neutral atoms maintain enough energy to implant or stick on the anode and on the pump walls where they will be buried by sputtered titanium and thus permanently pumped.

# Ion Pump Technical Notes

In the Diode configuration, the neutralization and back scattering probability is very small, thus the pumping speed for noble gases is only a small percentage of the N<sub>2</sub> pumping speed. Moreover, when operating at a relatively high argon partial pressure (i.e., higher than 10<sup>-8</sup> mbar), sudden bursts of pressure due to the re-emission of temporarily implanted argon in the cathode is observed. After this occurs, a Diode pump is not able to pump more argon until its source is stopped. This phenomenon is known as "argon instability".

Figure below shows that the StarCell® pump is superior in comparison to diode pumps with differential cathodes. The test was performed at 10<sup>-5</sup> mbar. The differential cathode diode showed instability after pumping about 3 mbar l of argon while the Starcell remained stable after pumping about 70 mbar l of argon, at which point the test was stopped.

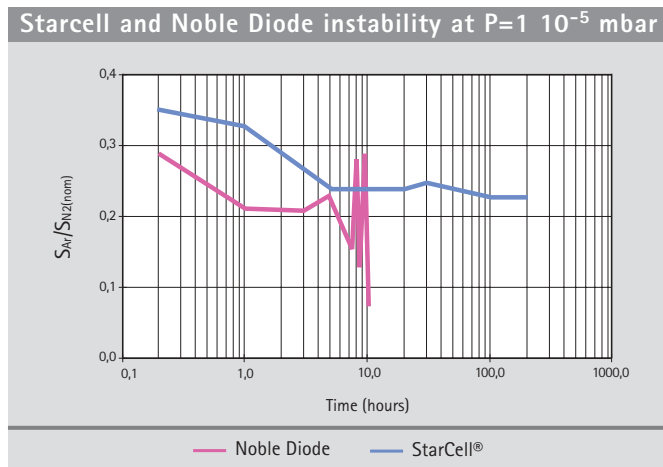

Figure 15

In the Noble Diode element, one titanium cathode is replaced with one tantalum cathode. The high nuclear mass of tantalum increases the back-scattering probability and consequently the pumping speed for noble gases.

The best results in terms of pumping speed of noble gases are obtained using the open cathode structure typical of StarCell® elements. In these configurations, the flat cathode structure has been replaced with a structure that allows glancing collisions with ions.

These are neutralized and then forward scattered toward the pump wall or the anode with a much higher probability than in the flat cathode case. The result is a pumping speed for noble gases of up to 60% of N<sub>2</sub>. Furthermore, due to the unique design that allows optimal use of all the available titanium, the operating life of a StarCell® pump is about 50% longer than all the other pumps.

## Methane

Although methane is not a noble gas, it does not react with any getter material. It is always present to some degree in UHV systems as a reaction product of hydrogen and carbon present in the vacuum system walls. Methane is a particular problem in electron accelerators where it is the main cause of the beam decay.

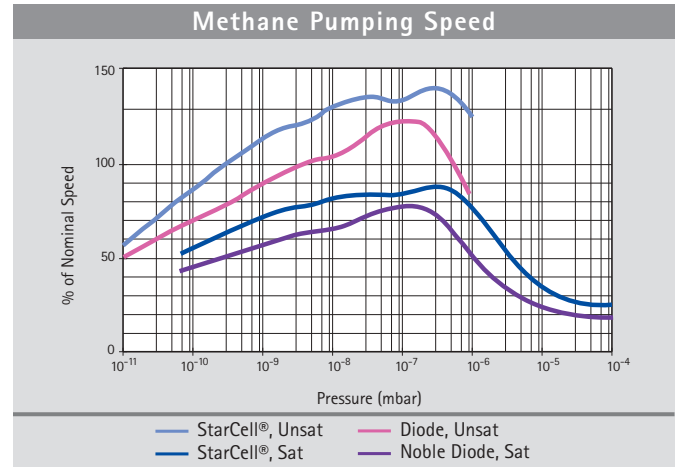

Figure 16

Due to the Penning discharge in ion pumps, the methane molecule (as well as other hydrocarbon molecules) is cracked and transformed into smaller gettable compounds (C, CH<sub>3</sub>, ... H). The result is that the pumping speed for methane and light hydrocarbons is always higher than the speed for N<sub>2</sub>.

## Basic Performance Factors

---

- Pumping speed, as in the case of any high vacuum pump, is one of the factors determining the ultimate (base) pressure of a system. However, ion pumps pump various gases at different rates – from very fast for hydrogen to quite slow for argon. Thus, it is necessary to check specifications to match the pump properly to the application. The pump's history in terms of gas load after a bakeout also influences pumping speed. Varian pumps are rated by their equilibrium or "saturated" speed levels. Unsaturated pumps temporarily deliver higher speeds, especially at UHV. A typical pumping speed vs pressure curve is shown on page 44.
- Maximum throughput of an ion pump is located in the  $10^{-4}$  to  $10^{-5}$  mbar pressure range. Since ion pumps are generally operated at much lower pressures, throughput is generally not a major consideration.
- Starting pressure is the pressure to which the ion pump must first be rough-pumped before the glow discharge will be confined to the anode cell structure and the pumping effect begins. To prevent pump overheating and possible damage when the pump is saturated at higher pressure, the controllers automatically reduce the output voltage to maintain power below a safety level.
- Pump life is determined by various factors, including cathode life; this is limited by cathode erosion, which is proportional to the average operating pressure. At  $10^{-6}$  mbar, cathode life ranges from 35,000 to 80,000 hours.
- Bakeability. In general, baking a UHV system and its ion pump to 200 to 250° C is adequate for outgassing, attaining low pressures after atmospheric exposure. Some processes require higher bakeout temperatures. In general, ion pump bodies can be baked at 450° C when the magnets are removed, or 350° C when the magnets are on the pump. When bakeable cables are connected to the ion pumps, temperature should not exceed 220° C.

# Titanium Sublimation Pump Technical Notes

## Titanium Sublimation Pumps

Thin films of reactive materials have been used for "gas cleanup" or "gettering" for over a century. The early electron tube makers were only able to mechanically pump to about  $1 \times 10^{-4}$  mbar, but through the use of "getters" flashed on the internal surfaces, pressures in the low  $10^{-7}$  mbar scale were attained. These getters were typically metals like barium, titanium, zirconium, or thorium. Gettering materials are still used in tubes today even though pressures of  $1 \times 10^{-8}$  mbar are readily attained by the pumps in the manufacturing process.

Gettering was not employed extensively in vacuum systems until the 1960's, when it was found to be highly compatible with ion pumping. Titanium was the metal commonly used because of its availability and its ability to sublime readily over a moderate temperature range.

### Applications

Due to cleanliness, bakeability, low power consumption, vibration-free operation, long pumping life, and high pumping speed, Titanium Sublimation Pumping (TSP) is the ideal cost-effective companion to ion pumping in ultrahigh vacuum.

Applications for this pumping mode are found in many areas, such as:

- Auger electron spectrometry
- Electron spectroscopy for chemical analysis
- Electron tube manufacturing
- Mass spectrometers
- Materials science conductor R&D
- Nuclear physics
- Outer space simulation
- Particle accelerators
- Secondary ion mass spectroscopy
- Solid state semiconductors

### Basic Performance Factors

- **Pumping Speed.** The pumping speed of a Ti film is proportional to the film area and to the sticking coefficient, that is the probability that an impinging gas molecule reacts with Ti forming a stable compound. The pumping speeds per unit area of a fresh evaporated Titanium film are reported in Table 1. Using these coefficients the intrinsic pumping speed ( $S_i$ ) of a Ti film can be evaluated using the following equation:

$$S_i[l/s] = \text{Coefficient} \times \text{Surface}$$

As the gas molecules react with the surface Ti atoms, the number of active sites decreases and, as a consequence, the pumping speed decreases. A plot of the specific pumping speed vs time at different pressures is reported in Figure 17. Using this plot it is possible to estimate how frequently the Ti film has to be renewed.

It must be noted that the actual pumping speed  $S$  of a TSP depends on the conductance  $C$  between the active surface and the vacuum vessel according to the following equation:

$$1/S = 1/C + 1/S_i$$

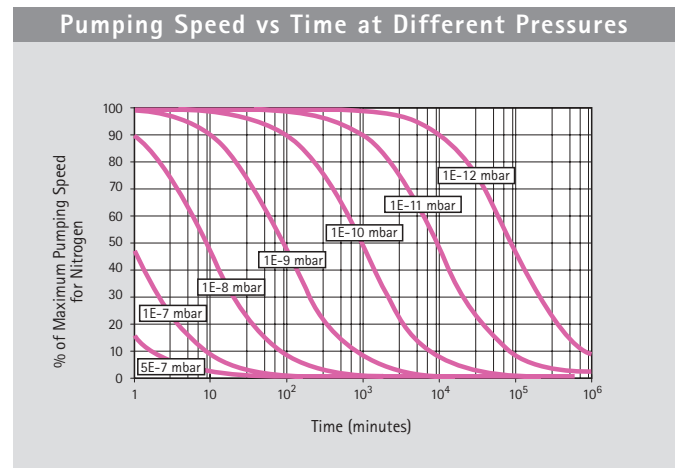

Figure 17

- **Throughput.** When the impingement rate of the gas molecules on the active film becomes higher than the Ti sublimation rate (excess of gas molecules respect the available Ti atoms), the pumping speed does not depend any more on the sticking coefficient. It is simply controlled by the quantity of the available Ti atoms according to stoichiometric reaction.

If  $n$  Ti atoms need to pump a gas molecule (example:  $2Ti + N_2 \rightarrow 2TiN$ ,  $n = 2$ ), the gas throughput  $Q$  is given by:

$$Q [mbar l/s] = \frac{0.13}{n} R \left[ \frac{gr}{h} \right]$$

where  $R$  is the Ti sublimation rate. In this condition the pumping speed is not constant but it depends on the pressure and is directly proportional to the sublimation rate (Figure 18).

Table 1

Typical pumping speeds per square inch (per square centimeter) of titanium sublimation surface for various gases (liters per second)

Gas	H <sub>2</sub>	N <sub>2</sub>	O <sub>2</sub>	CO	CO <sub>2</sub>	H <sub>2</sub> O	CH <sub>4</sub>	Ar	He
Surface Temperature	20 (3.1)	30 (4.7)	60 (9.3)	60 (9.3)	50 (7.8)	20 (3.1)	0	0	0
	-195° C	65 (10.1)	65 (10.1)	70 (10.9)	60 (9.3)	90 (13.9)	0	0	0

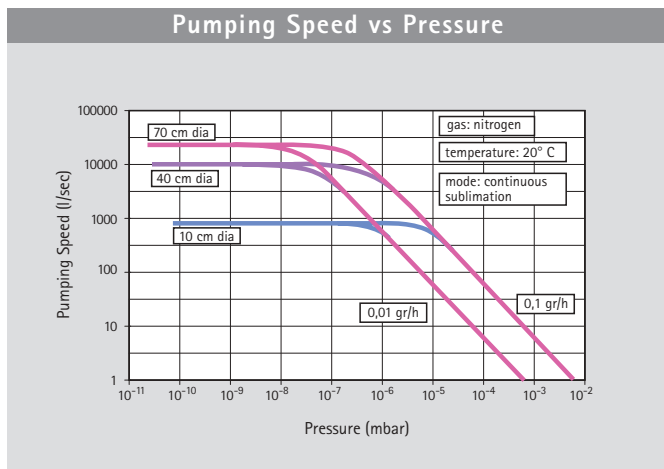

Figure 18

- Other factors. The overall performance of a titanium sublimation pump is a function of several variables, including gas species, pressure, gas temperature, getter film temperature, getter film area, the geometry of the area, sublimation rate, sticking coefficient, and the conductance from the film to the area being evacuated. For further information, write for "Predicting and Evaluating Titanium Sublimation Pump Performance" by D.J. Harra, 1974 (Vacuum Report VR-88).

**Operation**

Titanium Sublimation Pumping is accomplished by coating the inner surfaces of a vacuum system with sublimed titanium films. Since it involves a chemical reaction, this kind of pumping is useful where mainly active gases are present. The pumping speed of a unit area varies with various reactive gas species as shown in the following table. It can also be seen that cooling the substrate to liquid nitrogen temperature markedly increases the speed for hydrogen and water.

The gases thus "gettered" form stable compounds with titanium and are stored in the system as such until they are removed by cleaning. Since there is generally un-reacted pyrophoric titanium buried in the deposits, caution should be used in cleaning. If the desired gas throughput is known (Q = pumping speed x pressure) the maximum theoretical operating time is given by:

$$\text{Operating time [h]} = \frac{0.13 \quad T \text{ [gr]}}{n \quad Q \text{ [mbar l/s]}}$$

where T is the usable Titanium

For example, using our cryopanel at  $1 \times 10^{-8}$  mbar with a three filaments cartridge Ti source, the theoretical operating time is given by:

$$\frac{0.13}{2} \frac{3.6 \text{ [gr]}}{500 \text{ [l/s]} \times 10^{-8} \text{ [mbar]}} = 46,800 \text{ hrs} = \text{about 5 years}$$

After this time the filament cartridge should be replaced.

**Design Features**

- All sources are mounted on 2 3/4" Varian ConFlat Flanges and fit through 1 1/2" ports.
- The three-filament source contains 3.3 grams of useful titanium.
- The Varian Mini Ti-Ball source contains 15.2 grams of useful titanium.



# Ion Pump Service and Support Plan

Varian Vacuum Technologies offers one of the most comprehensive service and support plans in the industry. As a worldwide, first class company we strive to offer added value to our Customers wherever they may be located. Excellence in Service and Support is a key factor in added value.

Support can be accomplished with qualified Engineers and an appropriate logistic infrastructure. Technical skills and infrastructure are two areas where we are continuously making medium and long-term investments. Our daily customer support philosophy is focused on two important factors: quick response and no hassle.

Varian Vacuum Technologies is committed to providing our Customers with the most comprehensive service plans possible. The following pages detail the standard sections of our Ion Pump Service and Support Plan. For more information, or if you have a need for customized solutions, please contact your Varian representative. Often, excellent products are not enough: Varian's constant presence with Customer Service as a responsive partner is what really makes a difference.

## Worldwide Parts Sourcing Plan

### • Exchange and Repair Programs

Varian's Ion Pumps and Controllers offer unmatched reliability, performance and cleanliness. To maximize uptime, and for those occasions where time is essential, Varian offers exchange units for advance shipment. Exchange units are fully remanufactured to the same strict standards as new products. If requested, your Exchange unit can be shipped for overnight delivery. This efficiency is due to our logistic infrastructure and is the result of excellent teamwork among our Service and Customer Service Teams!

The Repair Program is available for those situations where the control of assets is important and when the requested turn around time is less critical. The Exchange and Repair Programs allow global OEMs and End-Users consistent delivery time, pricing, part numbers, and order processing procedures.

### • End User Extended Warranty

The End User Extended Warranty is a Service Agreement that provides coverage extension beyond the standard 12 months warranty of a product. It extends for additional 12 months the coverage from failures due to defects in material and workmanship.

By extending the warranty of purchased products, post-sales satisfaction is guaranteed. This is the result of the relevant cost decrease while cost predictability is increased. The End User Extended Warranty has been designed to cover the needs of the High Energy Physics Ultra High Vacuum applications.

### • Ordering Information for End User Extended Warranty

#### High Energy Physics UHV Applications Pumps

	Part Number
Extd. Warr. HEP 12M Ion Pump 20 l/s class	EW919VIP20
Extd. Warr. HEP 12M Ion Pump 40 l/s class	EW919VIP40
Extd. Warr. HEP 12M Ion Pump 55 l/s class	EW919VIP55
Extd. Warr. HEP 12M Ion Pump 75 l/s class	EW919VIP75
Extd. Warr. HEP 12M Ion Pump 150 l/s class	EW919VIP150
Extd. Warr. HEP 12M Ion Pump 500 l/s class	EW919VIP300
Extd. Warr. HEP 12M Ion Pump 150 l/s class	EW919VIP500
Extd. Warr. HEP 12M Ion Pump (other config.)	EW919VIP

#### Controllers

	Part Number
Extd. Warr. 12M Minivac Controller	EW929MINIVAC
Extd. Warr. 12M Dual Controller 1 Pump	EW929DUAP1P
Extd. Warr. 12M Dual Controller 2 Pumps	EW929DUAP2P
Extd. Warr. 12M TSP Controller	EW929TSP

## Technical Assistance

As a Varian Customer, you can rely on an attentive and professional support staff, dedicated to providing you with the easiest and most personalized service possible.

### • Customer Support

Our toll-free lines, with mother tongue Technical Support Engineers at worldwide locations, allow us to provide you with quick, corrective responses to your needs. Whenever a new problem is identified and solved by our support personnel, it is entered into our technical support system and becomes available to all Varian technical support centers. This system allows all Varian locations to provide excellent first and second level technical support to customers worldwide. In addition, the technical support centers are in daily contact with our R&D departments for third level support.

Call us today for more information.

### Americas

North America: Tel. 1.800.882.7426 (toll-free)  
Tel. 1.800.8VARIAN (toll-free)  
Fax (1) 781.860.5437

Central and South America: Tel. (1) 781.861.7200  
Fax (1) 781.860.5437

### Asia

Japan: Tel. 0120-655-040 (toll-free)  
Fax (81) 3.5232.1710 (dedicated line)

Korea: Tel. 080.222.2452 (toll-free)  
Fax (82) 2.3452.2451 (dedicated line)

Taiwan Tel. 0800-051342 (toll-free)  
Fax (886) 2.2698.9678 (dedicated line)

China Tel. 800.820.6556 (toll-free)  
Fax (86) 21.6375.6848 (dedicated line)

### Europe and Israel

Austria, Belgium, Finland, France, Germany, Holland, Ireland, Israel (\*), Italy, Portugal, Spain, Switzerland, UK:

Tel. 00.800.234.234.00 (toll-free)  
Fax 00.800.345.345.00 (fax free)

(\* From Israel dial 012 instead of initial 00)

### Other Countries

Tel. (39) 011.9979.369 (dedicated line)  
Fax (39) 011.9979.330 (dedicated line)

### • Application Support – Application Training

Varian has a leadership position in vacuum technology with continuous search for innovative solutions through research and development.

To meet the most demanding needs, our Application Engineer Team can bring our knowledge into your factory. Application Support is a project-based activity where our experts assist you towards the solution of your application issues that might arise both at pre and post-sale level. By designing solutions that meet Customers' needs, Varian aims to create a positive and synergetic relationship with customers.

Our experts can keep you well-informed and up-to-date on industrial and scientific applications with the goal of optimizing the use of our products on your system as well as the development of new vacuum techniques.

