

NOTICE: This document contains references to Varian. Please note that Varian, Inc. is now part of Agilent Technologies. For more information, go to www.agilent.com/chem.



Diffusion Pumps

Features and Benefits
2-3

Typical Applications
4-5

Pump Models
6-29

Fluids
30-31

Baffles
32-33

Technical Notes
34-37

Diffusion Pumps Features and Benefits

Varian has earned its position as the leading Diffusion Pump manufacturer in the world by listening to customer needs and by continuously improving the performance and reliability of our benchmark designs. Throughout our more than forty years of leadership in the industry, we have consistently produced pumps that provide the most efficient means of converting heat into pumping throughput.

Our experience has allowed us to optimize the design of every element of the pump. As a result, Varian Diffusion Pumps offer you the lowest cost of ownership available for many high vacuum-pumping applications.



Options to Address Your Needs

Many applications have unique requirements. Varian can provide additional features such as Halo or custom baffles to eliminate additional back-streaming, and a Quick Cool Coil option to accelerate system cycle times.

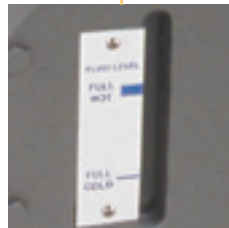

Easy to Maintain

Maintaining uptime is critical so we have simplified operation and maintenance. A sight glass provides visual indication of status when cold or hot and under vacuum. A gauge port facilitates system troubleshooting.



Fully Optimized Jet

Using our long and varied experience Varian designs and produces vapor jets that deliver the highest throughput, pressure stability, and tolerable foreline pressure available, while reducing backstreaming to a minimum.



Built for Production Volumes

Our success is in helping you meet the exacting requirements of your production process. Our pumps deliver superior pumping at high pressure and high gas flow conditions, and handle gas load variations that are typical of large volume production.



Robust Boiler Design

Through optimized boiler design, Varian pumps are stable and reliable under widely varying operating conditions. This temperature stability prolongs fluid life as well. Thermal protection switches prevent system over-temperature conditions.

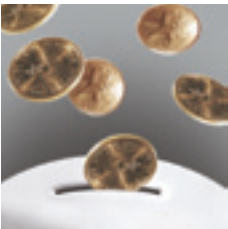

Low Cost of Ownership

By providing the highest throughput available per unit of power, reduced cooling water requirements, and rugged, durable stainless steel construction, Varian delivers large volume pumping at the lowest total cost to you.



World-class Service, Training and Support

Varian's application consulting capability makes use of our unparalleled experience to identify the optimal solution for you. And we invite you to take advantage of our industry leading worldwide service and support programs and award winning Vacuum Training classes to maximize system uptime and productivity.

Diffusion Pump Typical Applications



As the worldwide diffusion pump market leader, Varian produces the most comprehensive family of pumps, ranging from 2 in. to 35 in. in diameter, and is the only broad-line, U.S.-based manufacturer.

The diffusion pump is the most common type of pump for use in high vacuum applications. These vapor jet pumps are one of the oldest and most reliable ways to create a vacuum. Since the chamber itself has no moving parts aside from the oil droplets, a vacuum diffusion pump can operate with stability over long periods.

In all diffusion pumps, a small amount of backstreaming occurs. Backstreaming is the migration of minute levels of oil that move in the opposite direction— toward the inlet of the pump and into the process stream, which may be the stage of an electron microscope or a welding chamber. In some applications, minor backstreaming has no impact; in others, where the purity of materials is critical, backstreaming cannot be tolerated. For this reason, systems typically add an optically dense baffle of varying design to deflect oil particles before they can reach the process stream.

Diffusion pumps are in wide use because they have several advantages: They are reliable, simple in design, operate without noise or vibration, and are relatively inexpensive to operate and maintain. In fact, diffusion pumping is still the most economical means of creating high-vacuum environments. These pumps also tolerate operating conditions such as excess particles and reactive gases that would destroy other types of high-vacuum pumps.

With the proper choice of motive fluids, traps, baffles, and valves, diffusion pumps can be used in a wide variety of applications and over pressure ranges from 1×10^{-3} torr to 2×10^{-11} torr

Key Features of Varian Diffusion Pumps include:

- High pumping speeds
- High throughput
- High forepressure tolerance
- Low ultimate pressure
- Excellent backstreaming characteristics
- Long-term reliability



- **Vacuum Furnaces**

Vacuum furnace applications require pumps that are capable of achieving stable pressures in high gas flow environments. Additionally, furnace operators need shorter cycle times to accomplish efficient processing of heat-treated material batches.

Furnace operators derive these benefits from Varian vapor diffusion pumps, because the high throughput and low backstreaming rates of the pumps accommodate high material outgassing and allow higher cross-over pressures for shorter cycle times.

- **Metallizing**

In web and roll coating systems, Varian diffusion pumps have the ability to pump high gas loads making them the perfect choice for continuous production applications.

- **Large Area Coating /Thin Film Deposition**

Due to its simplicity, high performance and low initial costs, the diffusion pump remains a primary pumping mechanism for large area coating systems. The large pumps used

in this application come equipped with sight glass and drain assemblies and are also available with ASA or ISO flanges.

- **Coatings (Optical, Electronics, Protective)**

With low ultimate pressure, high speed, high throughput and high tolerable forepressure, Varian diffusion pumps are the best choice for developmental and production systems.

- **Molecular Beams**

The foreline ejector stage provides high tolerable forepressure and a large surface area for efficient degassing of compressed fluid, while the foreline baffle minimizes fluid loss even under high throughput conditions.

All Varian pumps incorporate an ejector stage as well as full fractionating jets. HS Series pumps create high speed and low ultimate pressure, high throughput and high tolerable forepressure and low backstreaming combine to make the HS series the best diffusion pump. Additionally, pumps are equipped with full thermal protection.

Diffusion Pump Models

	AX-65	HS-2	VHS-4	VHS-6	VHS-250
Previous Model Number		0160	0183	0184	0178
Pumping speed *, l/s (operating range)					
Air	65	160	750	1,550	2,125
Helium & Hydrogen	90	200	940	1,930	2,660
Pumping speed AVS 4.1 (1963)		285	1,200	2,400	3,700
Maximum forepressure, Torr (mbar)					
No load	0.75 (1.00)	0.55 (0.72)	0.65 (.86)	0.65 (0.85)	0.65 (.85)
Full load	0.60 (0.78)	0.40 (0.52)	0.55 (.73)	0.55 (0.72)	0.55 (0.72)
Maximum throughput,					
T-l/s (mbar-l/s) In operating range	0.19 (0.25)	0.60 (0.80)	1.5 (2.0)	2.4 (3.2)	2.6 (3.5)
@ 1 x 10 ⁻² Torr (1.3 x 10 ⁻² mbar)	0.30 (0.40)	0.70 (0.93)	2.5 (3.2)	3.5 (4.5)	3.5 (4.5)
Minimum recommended backing pump for maximum throughput, cfm (m ³ /hr)	0.15 (0.25)	5.0 (8.5)	10 (17)	17.0 (28.9)	17.0 (28.9)
Backstreaming rate at inlet flange mg/cm ² /min (standard cold cap)**	2 x 10 ⁻⁴	1 x 10 ⁻³	5 x 10 ⁻⁴	5 x 10 ⁻⁴	5 x 10 ⁻⁴
Warmup time, minutes	7	15	10	10	10
Cooldown time, minutes					
With quick cool coil, where applicable	10	10	10	10	10
Fluid charge	30cc	100 cc	300 cc	500 cc	500 cc
Electrical requirements	1 ph 50/60 Hz 90/115/165/220 V	1 ph 50/60 Hz 120/240 V	1 ph 50/60 Hz 120/208/240 V	1 ph 50/60 Hz 120/208/240 V	1 ph 50/60 Hz 120/208/240 V
Power, Watts	200/250	450	1450	2200	2200
Cooling water, U.S. gpm (l/hr) at 60-80° F (15-26 °C)	N/A	0.1 (20)	0.15 (30)	0.25 (50)	0.25 (50)

*For an explanation of pumping speed measurements, please see page 36.

** Refer to page 34 for a description of test methods.



VHS-10	VHS-400	HS-16	HS-20	HS-32	NHS-35
0185	0182	0164	0165	0167	0169
3,650 4,560 5,300	4,500 5,625 8,000	6,000 7,500 10,000	10,000 12,500 17,500	17,300 21,625 32,000	28,000 35,000 50,000
0.65 (.85) 0.55 (0.72)	0.65 (.85) 0.55 (0.72)	0.65 (.85) 0.55 (.72)	0.65 (.85) 0.55 (.72)	0.50 (.65) 0.35 (.45)	0.55 (.71) 0.40 (.52)
6.3 (8.4) 7.5 (10.0)	6.3 (8.4) 7.5 (10.0)	9.5 (11.7) at 8100 W 11.5 (15.3) at 8100 W	12.5 (16.7) 18 (23.4)	30 (40) 35 (45.5)	25 (33) 35 (45.5)
30 (51)	30 (51)	80 (136)	100 (170)	300 (510)	300 (510)
5 x 10 ⁻⁴	1 x 10 ⁻³	1.5 x 10 ⁻³	1.5 x 10 ⁻³	7 x 10 ⁻⁴	5 x 10 ⁻⁴
15	15	30	45	60	60
25	25	30	45	60	60
1,000 cc	1,000 cc	3 U.S. qts. (2.8 liters)	5 U.S. gal. (4.7 liters)	3 U.S. gal. (11.3 liters)	3 U.S. gal. (11.3 liters)
3 ph 50/60 Hz 208/240/380/480 V	3 ph 50/60 Hz 208/240/380/480 V	3 ph 50/60 Hz 240/415/480 V	3 ph 50/60 Hz 240/415/480 V	3 ph 50/60 Hz 240/415/480 V	50/60 Hz 240/415/480 V
4400	4400	8100/9600	12,000	24,000	24,000
0.40 (80)	0.40 (80)	1.5 (300)	1.5 (300)	4.0 (800)	4.0 (800)

Diffusion Pumps



AX-65

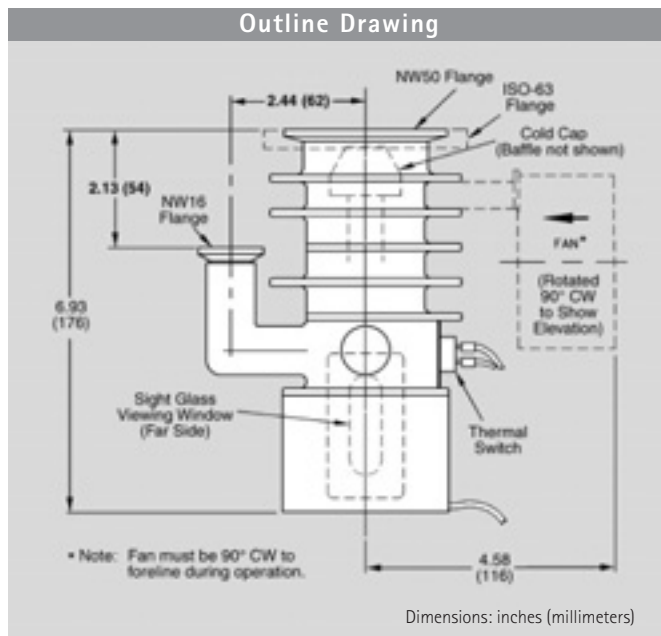

Technical Specifications

Pumping Speed*, Operating Range	65 l/sec Air, 90 l/s He and H ₂
Maximum Throughput	0.19T-l/s (0.25 mbar-l/s) in operating range 0.30T-l/s (0.40 mbar-l/s) @ 0.01 torr
Compression Ratio	4 x 10 ⁷ (Air), 2 x 10 ⁶ (helium)
Operating Range	3 x 10 ⁻³ to <5 x 10 ⁻⁸ torr (3.9 x 10 ⁻³ to 6.5 x 10 ⁻⁸ mbar)
Maximum Forepressure	No load: 0.75 torr (1.00 mbar) Full Load: 0.60 torr (0.78 mbar)
Backstreaming Rate**	With cold cap: < 2 x 10 ⁻⁴ mg/cm ² /min With baffle: < 2 x 10 ⁻⁵ mg/cm ² /min
Recommended Backing Pump	≥ 1.5 cfm (2.5 m ³ /hr)
Warmup Time	7 minutes
Cooldown Time	10 minutes
Fluid Charge	30 cc
Electrical Requirements	1 ph, 50/60 Hz, 90/115/165/220 VAC
Pump Power	200/250 watts
Air Cooling	30 cfm

*For an explanation of pumping speed measurements, please see page 36.

**Refer to page 34 for a description of test methods.

Speed Curve

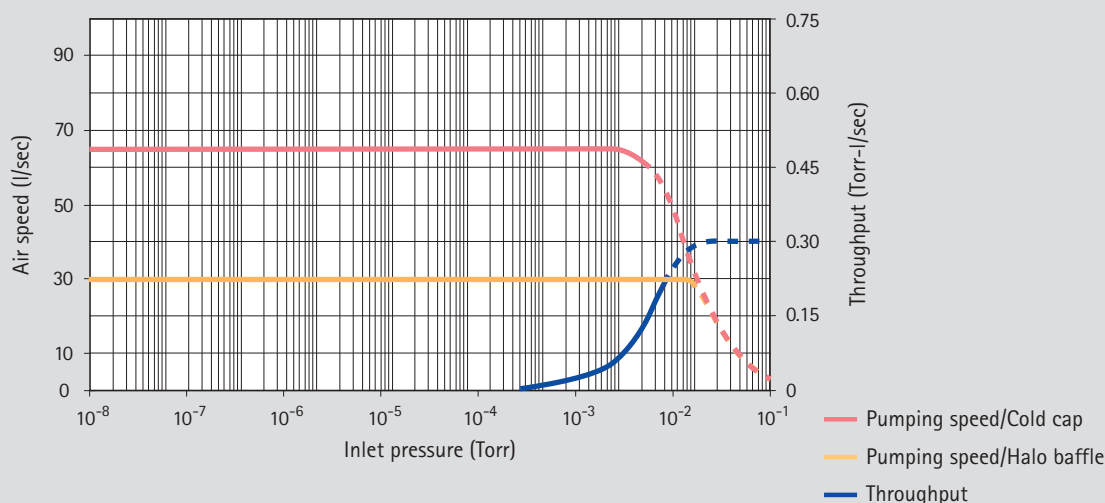

Diffusion Pumps

Ordering Information

Description	Wt. kg (lbs)	Part Number	
		KF-50	ISO-6
AX-65 with standard cold cap, 115 V, 250 W	3.6 (8.0)	L9670301	L9707301
AX-65 with internal baffle, 115 V, 250 W	3.6 (8.0)	L9670311	L9707311
AX-65 with standard cold cap, 220 V, 250 W	3.6 (8.0)	L9670302	L9707302
AX-65 with internal baffle, 220 V, 250 W	3.6 (8.0)	L9670312	L9707312
AX-65 with standard cold cap, 115 V, 200 W	3.6 (8.0)	L9670303	L9707303
AX-65 with internal baffle, 115 V, 200 W	3.6 (8.0)	L9670313	L9707313
AX-65 with standard cold cap, 220 V, 200 W	3.6 (8.0)	L9670304	L9707304
AX-65 with internal baffle, 220 V, 200 W	3.6 (8.0)	L9670314	L9707314
AX-65 with standard cold cap, 90 V, 250 W	3.6 (8.0)	L9670305	L9707305
AX-65 with internal baffle, 90 V, 250 W	3.6 (8.0)	L9670315	L9707315
AX-65 with standard cold cap, 165 V, 250 W	3.6 (8.0)	L9670306	L9707306
AX-65 with internal baffle, 165 V, 250 W	3.6 (8.0)	L9670316	L9707316

- NOTE**
- All pumps have NW-16 foreline
 - See page 30 for Santovac 5 diffusion pump fluid
 - Mounted cooling fan included with each pump (P/N 661300138)
 - Overtemperature thermal switch set to open at 365° F (182 °C)
 - Use 250W heater with polyphenyl ether fluids (such as DC-705 and Santovac 5). Use 200W heater for other fluids.

Description	Wt. kg (lbs)	Part Number
Accessories		
Santovac 5 diffusion pump fluid, 40 cc	0.5 (1.0)	695405001
Santovac 5 diffusion dump fluid, 65 cc	0.9 (2.0)	695405002
DC-704 diffusion pump fluid, 500 cc	1.4 (3.0)	695474005
DC-705 diffusion pump fluid, 500 cc	1.4 (3.0)	695475005
Internal baffle kit	0.9 (2.0)	R1160065
Centering ring for inlet flange, NW50	0.5 (1.0)	KC50SB
Centering ring for inlet flange, ISO-63	0.2 (0.5)	IC063SV
Centering ring for foreline flange, NW16	0.2 (0.5)	KC16SB
Instruction manual		699901062

Replacement Parts (one heater harness required per pump)		
200 W, 115 V heater harness (for use with DC-704 and DC-702)	0.5 (1.0)	L9994307
250 W, 115 V heater harness (for use with DC-705 and Santovac 5)	0.5 (1.0)	L9994303
200 W, 220 V heater harness (for use with DC-704 and DC-702)	0.5 (1.0)	L9994308
250 W, 220 V heater harness (for use with DC-705 and Santovac 5)	0.5 (1.0)	L9994304
250 W, 90 V heater harness (for use with DC-705 and Santovac 5)	0.5 (1.0)	L9994301
250 W, 165 V heater harness (for use with DC-705 and Santovac 5)	0.5 (1.0)	L9994302
Overtemperature thermal switch (included with each heater harness)	0.5 (1.0)	L9964001
Pump ready thermal switch (optional)	0.5 (1.0)	L9964002

HS-2

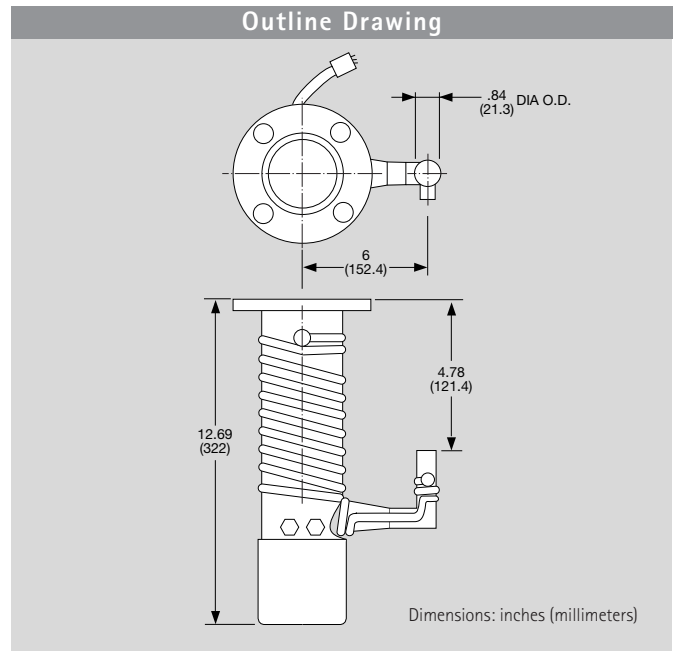

Technical Specifications

Pumping Speed, Operating Range	160 l/s Air, 200 l/s He and H ₂
Pumping Speed*, AVS 4.1 (1963)	285 l/s Air
Maximum Throughput	0.60 T-l/s (0.80 mbar-l/s) in operating range 0.70 T-l/s (0.93 mbar-l/s) @ 0.01 torr
Operating Range	3.7×10^{-3} to $< 5 \times 10^{-8}$ torr, (4.9×10^{-3} to $< 6.5 \times 10^{-8}$ mbar)
Maximum Forepressure	No Load: 0.55 torr (0.71 mbar) Full Load: 0.40 torr (0.52 mbar)
Recommended Backing Pump	≥ 5 cfm (8.5 m ³ /hr)
Backstreaming Rate**, Standard Cold Cap	$< 1 \times 10^{-3}$ mg/cm ² /min
Warmup Time	15 minutes
Cooldown Time	10 minutes (with quick cool coil)
Fluid Charge	100 cc
Electrical Requirements	1 ph, 50/60 Hz, 120/240 VAC
Pump Power	450 watts
Cooling Water Requirements	0.1 gpm (20 l/hr) at 60-80° F (15-26 °C)
Water Connections	1/8 in. FPT

*For an explanation of pumping speed measurements, please see page 36.

**Refer to page 34 for a description of test methods

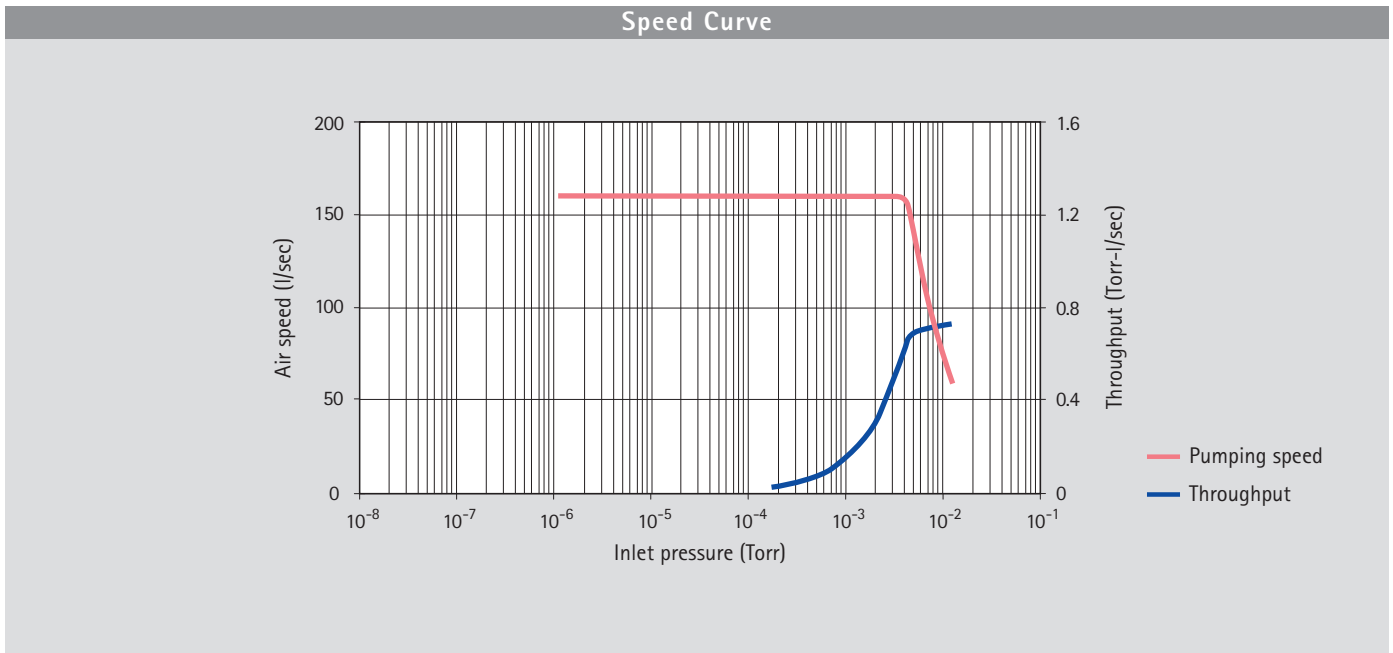

Diffusion Pumps

Ordering Information

Description	Wt. kg (lbs)	Part Number
ASA		
With standard cold cap, 120 V	20.0 (9.0)	82906301
With standard cold cap, 240 V	20.0 (9.0)	82906302
Accessories	Wt. kg (lbs)	Part Number
Water-cooled baffle with ASA flanges	10.0 (4.5)	F9453302
Santovac 5 diffusion pump fluid, 500 cc pump fluid, 500 cc	2.5 (1.1)	695405005
DC-702 diffusion pump fluid, 500 cc	3.0 (1.4)	695472005
DC-704 diffusion pump fluid, 500 cc	3.0 (1.4)	695474005
DC-705 diffusion pump fluid, 500 cc	3.0 (1.4)	695475005
Instruction manual		699901150

Description	Wt. kg (lbs)	Part Number
Replacement Parts (one heater required per pump)		
350 W, 120 V heater (HS2A)	1.0 (0.5)	647301100
350 W, 240 V heater (HS2A)	1.0 (0.5)	647301125
450 W, 120 V heater	1.0 (0.5)	647302125
450 W, 240 V heater	1.0 (0.5)	647302150
Heater block (one required per pump)	1.0 (0.5)	82920001
Heater platen (one required per pump)	1.0 (0.5)	82918301
Replacement o-ring kit, (5 Inlet flange o-rings (butyl 2-338))	1.0 (0.5)	K0377159

- NOTE**
- Inlet flange: nominal 2 in. ASA flange with 6 in. OD
 - Foreline flange: 0.84 in. diameter tube
 - See page 32 for Baffles
 - See page 30 for Santovac 5 diffusion pump fluid

VHS-4

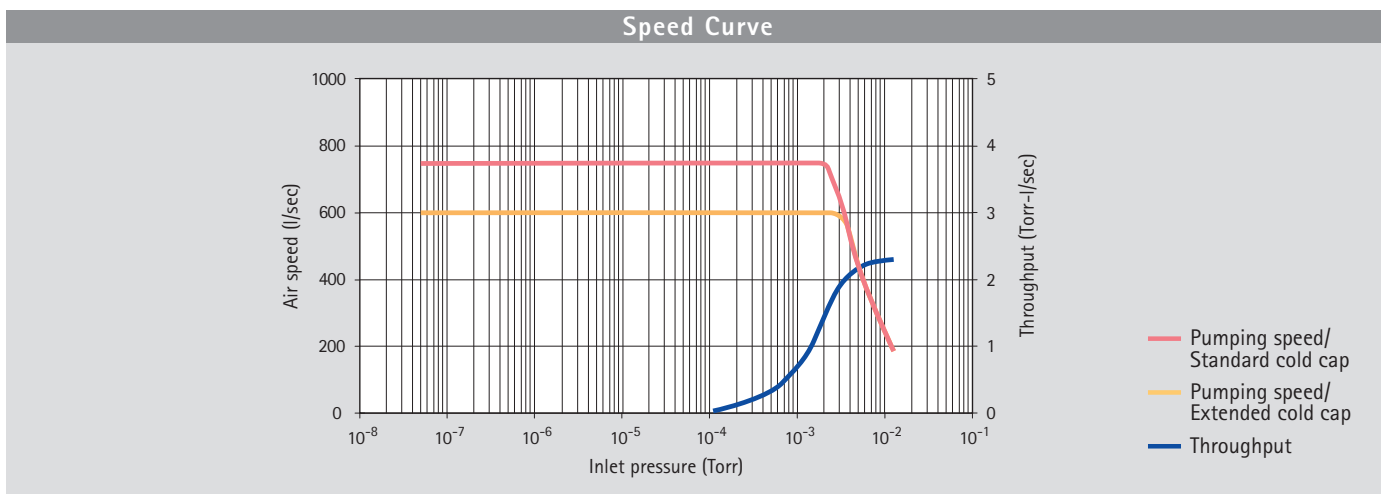
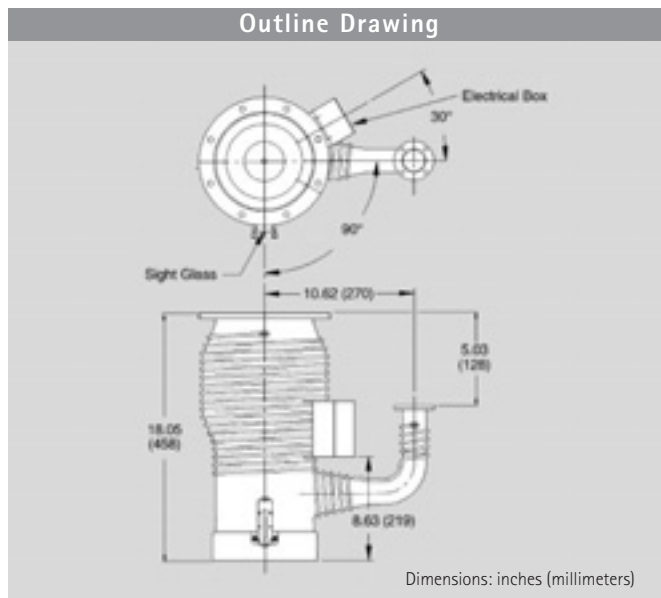

Technical Specifications

Pumping Speed*, Operating Range	750 l/s air, 940 l/s He/H ₂
Pumping Speed*, AVS 4.1 (1963)	1,200 l/s Air
Maximum Throughput	1.5 T-l/s (2.0 mbar-l/s) in operating range, 2.5 T-l/s (3.2 mbar-l/s) @ 0.01 torr
Operating Range	2×10^{-3} to $< 5 \times 10^{-9}$ torr (2.7×10^{-3} to $< 6.5 \times 10^{-9}$ mbar)
Maximum Forepressure	No Load: 0.65 torr (0.86 mbar) Full Load: 0.55 torr (0.73 mbar)
Recommended Backing Pump	≥ 10 cfm (17 m ³ /hr)
Backstreaming Rate**, Standard Cold Cap	$< 5 \times 10^{-4}$ mg/cm ² /min
Warmup Time	10 minutes
Cooldown Time	10 minutes (with quick cool coil)
Fluid Charge	300 cc
Electrical Requirements	1 ph, 50/60 Hz, 120/208/240 VAC
Pump Power	1450 watts
Cooling Water Requirements	0.15 gpm (30 l/hr) at 60-80° F (15-26 °C)
Water Connections	1/8 in. FPT Tee

*For an explanation of pumping speed measurements, please see page 36.

**Refer to page 34 for a description of test methods.

Ordering Information

Description	Voltage	Weight kg (lbs)	Part Number	
			Flange Type ASA	ISO
VHS-4 Pump				
VHS-4 with standard cold cap	120 V	25.0 (55.0)	86460301	L6256301
VHS-4 with extended cold cap	120 V	25.0 (55.0)	86460311	L6256311
VHS-4 with standard cold cap	208 V	25.0 (55.0)	86460306	L6256306
VHS-4 with extended cold cap	208 V	25.0 (55.0)	86460316	L6256316
VHS-4 with standard cold cap	240 V	25.0 (55.0)	86460302	L6256302
VHS-4 with extended cold cap	240 V	25.0 (55.0)	86460312	L6256312
Accessories				
	Page	Weight kg (lbs)	Part Number	
Water-cooled baffle with ASA flanges	32	4.5 (10.0)	F8286304	
Water-cooled baffle with ISO flanges	32	4.5 (10.0)	F8286305	
Centering ring for ISO inlet flange, 160K		0.5 (1.0)	IC160SV	
Centering ring for ISO foreline flange, KF40		0.2 (0.5)	KC40SV	
Santovac 5 diffusion pump fluid, 500 cc	30	1.1 (2.5)	695405005	
DC-702 diffusion pump fluid, 500 cc	30	1.4 (3.0)	695472005	
DC-704 diffusion pump fluid, 500 cc	30	1.4 (3.0)	695474005	
DC-705 diffusion pump fluid, 500 cc	30	1.4 (3.0)	695475005	
Instruction manual			699901021	
Replacement Parts (one heater required per pump)				
1450 W, 120 V heater		0.5 (1.0)	647304205	
1450 W, 208 V heater		0.5 (1.0)	647304210	
1450 W, 240 V heater		0.5 (1.0)	647304250	
Heater clamp (one required per pump)		1.0 (2.0)	88164301	
Replacement nickel heater wire (#10 AWG)		0.5 (0.2)	656179100	
Replacement o-ring kit (kit contains: 3 inlet flange o-rings (butyl 2-258), 10 fill and drain o-rings (Viton 2-113), sight glass o-ring and gasket)		0.5 (1.0)	K0377183	
Thermal switch (set at 300° F – 147 °C)		0.5 (1.0)	642906025	
Extended cold cap	33	0.5 (1.0)	F6898301	
Sight glass repair kit			L8908301	
Basic sight glass cooling kit			R1523301	
Extended sight glass cooling kit			R1208301	

- NOTE**
- Inlet flange 4 in. ASA, foreline flange KF40
 - Inlet flange ISO 160K, foreline flange ISO KF40
 - Pumps with ISO flanges do not include required centering rings

VHS-6

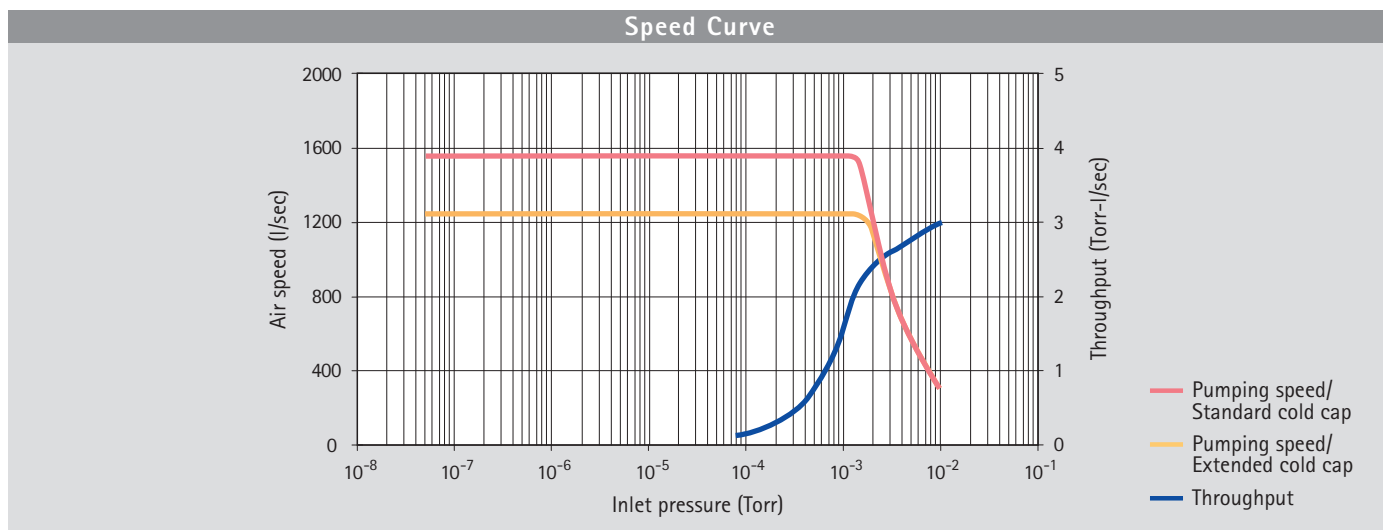
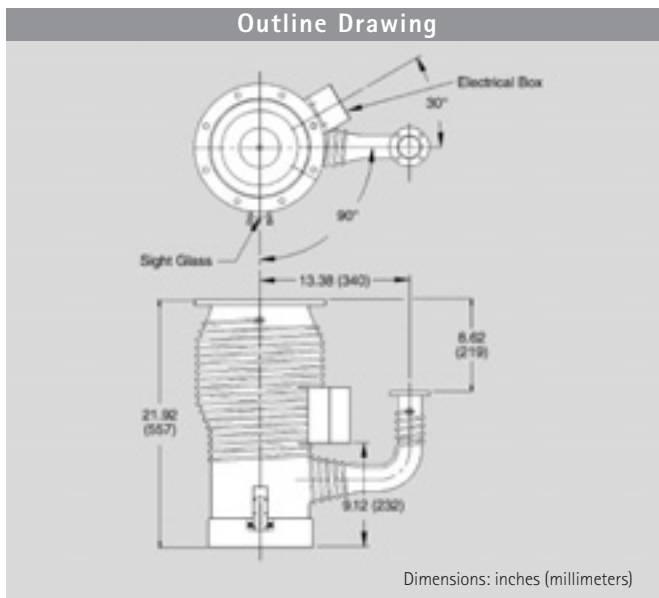

Technical Specifications

Pumping Speed, Operating Range	1,550 l/s Air, 1,930 l/s He/H ₂
Pumping Speed*, AVS 4.1 (1963)	2,400 l/s Air
Maximum Throughput	2.4 T-l/s (3.2 mbar-l/s) in operating range, 3.5 T-l/s (4.5 mbar-l/s) @ 0.01 torr
Operating Range	1.5×10^{-3} to $< 5 \times 10^{-9}$ torr (2×10^{-3} to $< 6.5 \times 10^{-9}$ mbar)
Maximum Forepressure	No Load: 0.65 torr (0.85 mbar) Full Load: 0.55 torr (0.72 mbar)
Recommended Backing Pump	≥ 17 cfm (29 m ³ /hr)
Backstreaming Rate**, Standard Cold Cap	$< 5 \times 10^{-4}$ mg/cm ² /min
Warmup Time	10 minutes
Cooldown Time	10 minutes (with quick cool coil)
Fluid Charge	500 cc – exact fluid charge available
Electrical Requirements	1 ph, 50/60 Hz, 120/208/240 VAC
Pump Power	2200 watts
Cooling Water Requirements	0.25 gpm (50 l/hr) at 60–80° F (15–26 °C)
Water Connections	1/8 in. FPT Tee

*For an explanation of pumping speed measurements, please see page 36.

**Refer to page 34 for a description of test methods.

Ordering Information

Description	Voltage	Weight kg (lbs)	Part Number	
			ASA	ISO
VHS-6 Pump				
VHS-6 with standard cold cap	120 V	34.0 (75.0)	85826301	L6193301
VHS-6 with extended cold cap	120 V	34.0 (75.0)	85826311	L6193311
VHS-6 with standard cold cap	208 V	34.0 (75.0)	85826306	L6193306
VHS-6 with extended cold cap	208 V	34.0 (75.0)	85826316	L6193316
VHS-6 with standard cold cap	240 V	34.0 (75.0)	85826302	L6193302
VHS-6 with extended cold cap	240 V	34.0 (75.0)	85826312	L6193312
Accessories				
	Page	Weight kg (lbs)	Part Number	
Water-cooled baffle with ASA flanges	32	7.0 (15.0)	F8277306	
Water-cooled baffle with ISO flanges	32	7.0 (15.0)	F8277307	
Santovac 5 diffusion pump fluid, 500 cc (exact pump charge)	30	1.1 (2.5)	695405005	
DC-702 diffusion pump fluid, 500 cc (exact pump charge)	30	1.4 (3.0)	695472005	
DC-704 diffusion pump fluid, 500 cc (exact pump charge)	30	1.4 (3.0)	695474005	
DC-705 diffusion pump fluid, 500 cc (exact pump charge)	30	1.4 (3.0)	695475005	
Centering ring for ISO inlet flange, 200K		0.5 (1.0)	IC200SV	
Centering ring for ISO foreline flange, KF50		0.2 (0.5)	KC50SV	
Instruction manual			699901022	
Replacement Parts (one heater required per pump)				
2200 W, 120V heater		0.5 (1.0)	647306125	
2200 W, 208V heater		0.5 (1.0)	647306175	
2200 W, 240V heater		0.5 (1.0)	647306225	
Heater clamping assembly (includes clamping plate, cover plate, insulator)			86643301	
Heater cover plate (one required per pump)		1.0 (2.0)	86088001	
Heater insulator (one required per pump)		0.2 (0.5)	86087001	
Heater clamping plate (one required per pump)		0.5 (1.0)	86086301	
Replacement nickel heater wire		0.5 (1.0)	656179100	
Replacement o-ring kit (kit contains: 3 inlet flange o-rings (butyl 2-267), 3 foreline flange o-rings (butyl 2-332), sight glass o-ring and gasket, 10 fill and drain o-rings (Viton 2-113))		0.5 (1.0)	K0377184	
Thermal switch (set at 300° F – 147 °C)		0.5 (1.0)	642906025	
Extended cold cap	33	0.5 (1.0)	F6455001	

NOTE • Inlet flange 6 in. ASA, foreline flange 1.5 in. ASA
 Inlet flange ISO 200K, foreline flange ISO KF50
 Pumps with ISO flanges do not include required centering rings

VHS-250

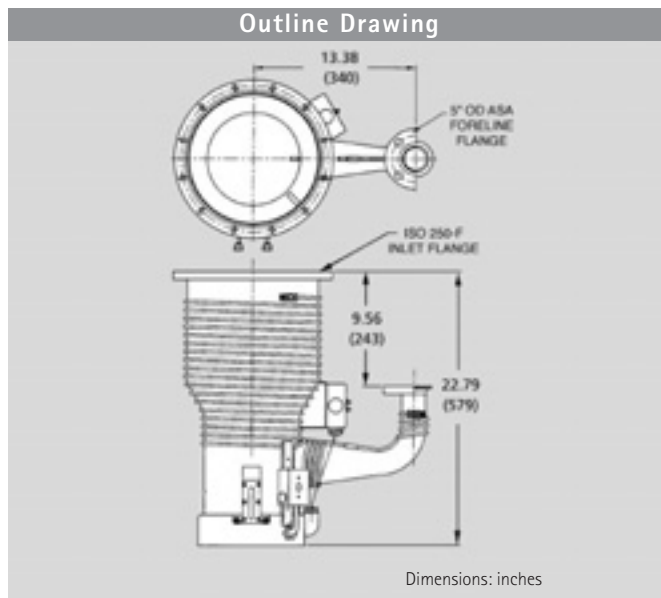

Technical Specifications

Pumping Speed, Operating Range	2,125 l/s Air, 2,660 l/s He/H ₂
Pumping Speed*, AVS 4.1 (1963)	3,700 l/s Air
Maximum Throughput	2.6 T-l/s (3.5 mbar-l/s) in operating range, 3.5 T-l/s (4.5 mbar l/s) @ 0.01 torr
Operating Range	1.2×10^{-3} to $< 5 \times 10^{-9}$ torr (1.6×10^{-3} to $< 6.5 \times 10^{-9}$ mbar)
Maximum Forepressure	No Load: 0.65 torr (0.85 mbar) Full Load: 0.55 torr (0.72 mbar)
Recommended Backing Pump	≥ 17 cfm (29 m ³ /hr)
Backstreaming Rate**, Standard Cold Cap	$< 5.0 \times 10^{-4}$ mg/cm ² /min
Warmup Time	10 minutes
Cooldown Time	10 minutes (with quick cool coil)
Fluid Charge	500 cc – exact fluid charge available
Electrical Requirements	1 ph, 50/60 Hz, 120/208/240 VAC
Pump Power	2200 watts
Cooling Water Requirements	0.25 gpm (50 l/hr)
Water Connections	1/8 in. FPT Tee

*For an explanation of pumping speed measurements, please see page 36.

**Refer to page 34 for a description of test methods.

Speed Curve

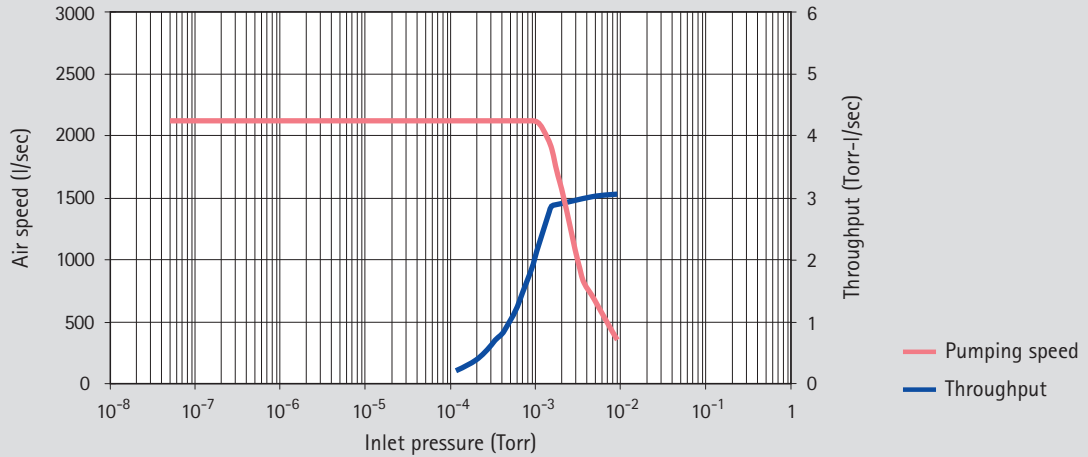

Ordering Information

Description	Voltage	Weight kg (lbs)	Part Number
VHS-250 Pump			
VHS-250 with standard cold cap	120V	34.0 (75.0)	K0543301
VHS-250 with standard cold cap	208V	34.0 (75.0)	K0543306
VHS-250 with standard cold cap	240V	34.0 (75.0)	K0543302
Accessories			
Santovac 5 diffusion pump fluid, 500 cc (exact pump charge)		1.1 (2.5)	695405005
DC-702 diffusion pump fluid, 500 cc (exact pump charge)		1.4 (3.0)	695472005
DC-704 diffusion pump fluid, 500 cc (exact pump charge)		1.4 (3.0)	695474005
DC-705 diffusion pump fluid, 500 cc (exact pump charge)		1.4 (3.0)	695475005
Instruction manual			699901020
Replacement Parts (one heater required per pump)			
2200 W, 120 V heater		0.5 (1.0)	647306125
2200 W, 208 V heater		0.5 (1.0)	647306175
2200 W, 240 V heater		0.5 (1.0)	647306225
Heater cover plate (one required per pump)		1.0 (2.0)	86088001
Heater insulator (one required per pump)		0.2 (0.5)	86087001
Heater clamping plate (one required per pump)		0.5 (1.0)	86086301
Replacement nickel heater wire		0.5 (1.0)	656179100
Replacement o-ring kit (kit contains: 3 inlet flange o-rings (butyl 2-379), 3 foreline flange o-rings (butyl 2-332), sight glass o-ring and gasket, 10 fill and drain o-rings (Viton 2-113))		0.5 (1.0)	K0377178
Thermal switch (set at 300° F - 147 °C)		0.5 (1.0)	642906025

NOTE • Inlet flange: ISO 250F (bolted, o-ring seal)
 • Foreline flange: ASA with 5 in. OD

VHS-10

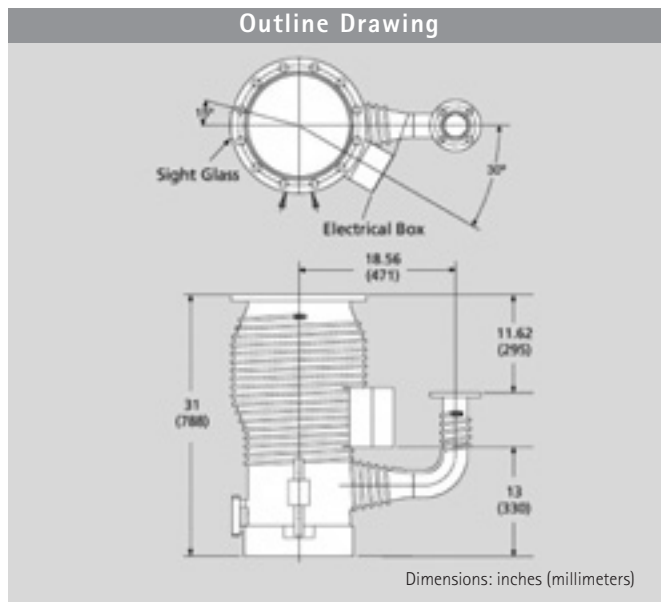

Technical Specifications

Pumping Speed, Operating Range	3,650 l/s Air, 4,560 l/s He/H ₂
Pumping Speed*, AVS 4.1 (1963)	5,300 l/s Air
Maximum Throughput	6.3 T-l/s (8.4 mbar l/s) in operating range 7.5 T-l/s (10.0 mbar l/s) @ 0.01 torr
Operating Range	1.7×10^{-3} to $< 5 \times 10^{-9}$ torr at 4400 W (2.3×10^{-3} to $< 6.5 \times 10^{-9}$ mbar)
Maximum Forepressure	No Load: 0.65 torr (0.85 mbar) Full Load: 0.55 torr (0.72 mbar)
Recommended Backing Pump	≥ 30 cfm (51 m ³ /hr)
Backstreaming Rate**, Standard Cold Cap	$< 5.0 \times 10^{-4}$ mg/cm ² /min
Warmup Time	15 minutes
Cooldown Time	25 minutes
Fluid Charge	1,000 cc
Electrical Requirements	3 ph, 50/60 Hz, 208/240/380/480 VAC
Pump Power	4400 watts
Cooling Water Requirements	0.40 gpm (80 l/hr)
Water Connections	1/8 in. FPT Tee

*For an explanation of pumping speed measurements, please see page 36.

**Refer to page 34 for a description of test methods.

Speed Curve

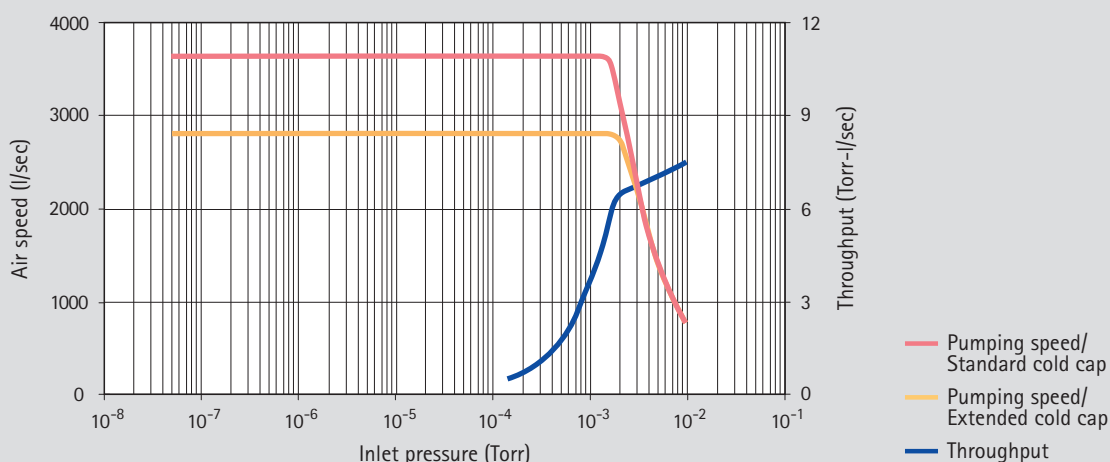

Ordering Information

Description	Wt. kg (lbs)	Part Number	
		ASA	ISO
VHS-10 with standard cold cap, 208 V	68 (150)	F0426307	L5920307
VHS-10 with extended cold cap, 208 V	68 (150)	F0426317	L5920317
VHS-10 with standard cold cap, 240 V	68 (150)	F0426308	L5920308
VHS-10 with extended cold cap, 240 V	68 (150)	F0426318	L5920318
VHS-10 with standard cold cap, 380 V	68 (150)	F0426326	L5920326
VHS-10 with extended cold cap, 380 V	68 (150)	F0426336	L5920336
VHS-10 with standard cold cap, 480 V	68 (150)	F0426309	L5920309
VHS-10 with extended cold cap, 480 V	68 (150)	F0426319	L5920319

Accessories	Wt. kg (lbs)	Part Number
Water-cooled baffle with ASA flanges	9.0 (20.0)	F8600310
Water-cooled baffle with ISO flanges	9.0 (20.0)	F8600311

NOTE

- Inlet flange 10 in. ASA, foreline flange 2 in. ASA
- Inlet flange ISO 320K, foreline ISO 63K
- See page 30 Santovac 5 diffusion pump fluid
- Baffles and extended cold caps can be found on pages 33 and 34 respectively

Description	Wt. kg (lbs)	Part Number
Accessories (Cont'd)		
DC-702 diffusion pump fluid, 500 cc (two required)	2.8 (6.0)	695472005
DC-704 diffusion pump fluid, 500 cc (two required)	2.8 (6.0)	695474005
DC-705 diffusion pump fluid, 500 cc (two required)	2.8 (6.0)	695475005
Centering ring for ISO foreline flange, 63K	0.5 (1.0)	IC063SV
Instruction manual		699901023

Replacement Parts (two heaters required per pump)		
2200 W, 208 V heater	0.5 (1.0)	647310140
2200 W, 240 V heater	0.5 (1.0)	647310150
2200 W, 380 V heater	0.5 (1.0)	647310160
2200 W, 480 V heater	0.5 (1.0)	647310170
2550 W, 208 V heater	0.5 (1.0)	647310145
2550 W, 240 V heater	0.5 (1.0)	647310155
2550 W, 380 V heater	0.5 (1.0)	647310165
2550 W, 480 V heater	0.5 (1.0)	647310175
Heater crush plate (covers both heaters; one required for pump; replace when either heater is replaced)	1.0 (2.0)	K7667001
Heater clamping plate (one required per pump)	0.5 (1.0)	R2667301
Replacement nickel heater wire (#10 AWG)	0.5 (1.0)	656179100
Replacement o-ring kit (kit contains: 1 inlet flange o-ring (butyl F0430001), 1 foreline flange o-ring (butyl 2-338), sight glass o-ring and gasket, 10 fill and drain o-rings (Viton 2-113))	1.0 (0.5)	K0377185
Thermal switch (set at 300° F – 147 °C)	0.5 (1.0)	642906025
Extended cold cap	2.0 (0.9)	L8917301

VHS-400

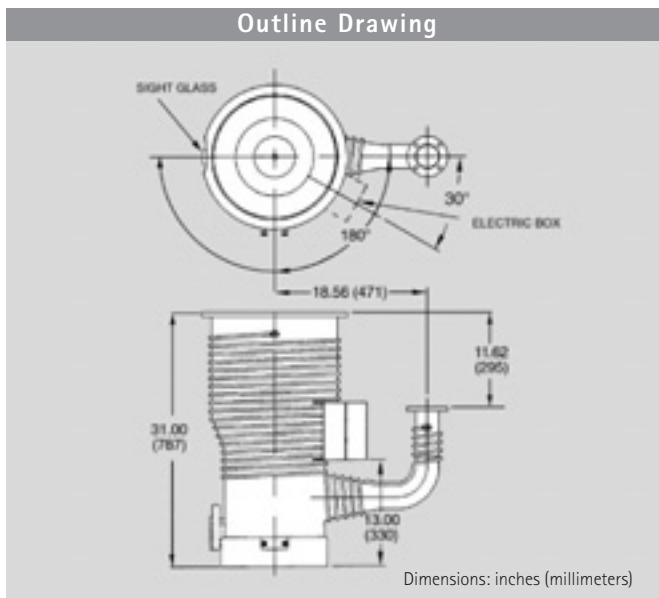

Technical Specifications

Pumping Speed, Operating Range	4,500 l/s Air, 5,625 l/s He/H ₂
Pumping Speed*, AVS 4.1 (1963)	8,000 l/s Air
Maximum Throughput	6.3 T-l/s (8.4 mbar l/s) in operating range 7.5 T-l/s (10.0 mbar l/s) @ 0.01 torr
Operating Range	1.4×10^{-3} to $< 5 \times 10^{-9}$ torr (1.9×10^{-3} to $< 6.5 \times 10^{-9}$ mbar)
Maximum Forepressure	No Load: 0.65 torr (0.85 mbar) Full Load: 0.55 torr (0.72 mbar)
Recommended Backing Pump	≥ 30 cfm (51 m ³ /hr)
Backstreaming Rate**, Standard Cold Cap	$< 1.0 \times 10^{-3}$ mg/cm ² /min
Warmup Time	15 minutes
Cooldown Time	25 minutes
Fluid Charge	1,000 cc
Electrical Requirements	3 ph, 50/60 Hz, 208/380/480 VAC
Pump Power	4400 watts
Cooling Water Requirements	0.40 gpm (80 l/hr)
Water Connections	1/8 in. FPT Tee

*For an explanation of pumping speed measurements, please see page 36.

**Refer to page 34 for a description of test methods.

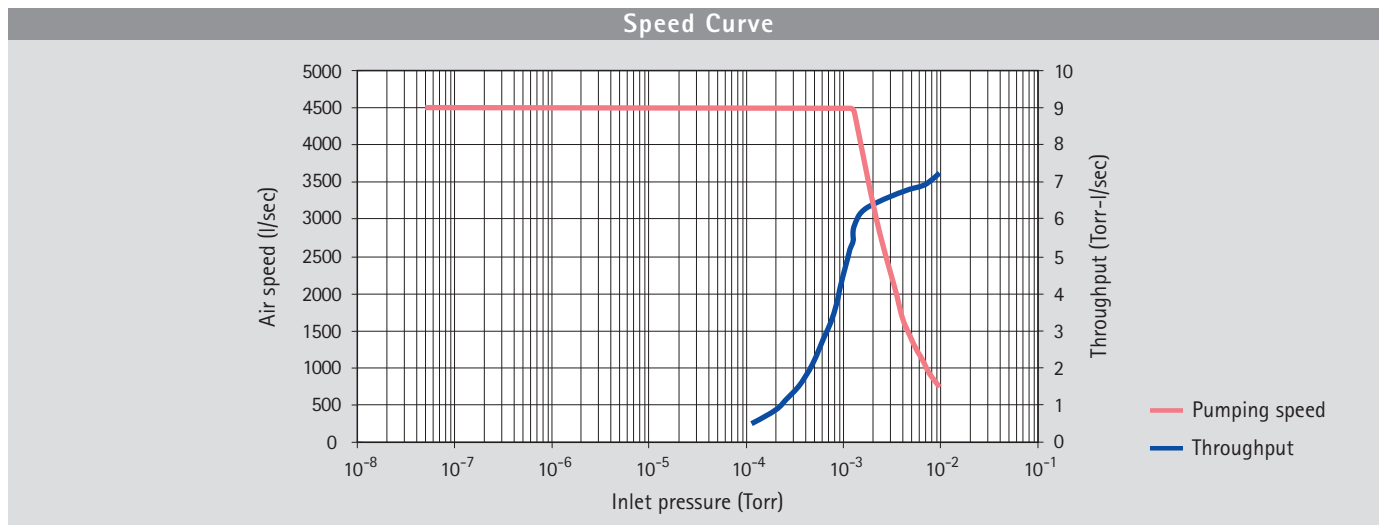

Ordering Information

Description	Voltage	Weight kg (lbs)	Part Number	
			Flange Type ASA	ISO
VHS-400 Pump				
VHS-400 with standard cold cap	208 V	75.0 (180.0)	K4816307	L9767307
VHS-400 with standard cold cap	380 V	75.0 (180.0)	K4816326	L9767326
VHS-400 with standard cold cap	480 V	75.0 (180.0)	K4816309	L9767309
VHS-400 with standard cold cap	240 V	75.0 (180.0)	K4816308	L9767308
Accessories				
	Page	Weight kg (lbs)	Part Number	
DC-702 diffusion pump fluid, 500 cc (two required)	30	2.8 (6.0)	695472005	
DC-704 diffusion pump fluid, 500 cc (two required)	30	2.8 (6.0)	695474005	
DC-705 diffusion pump fluid, 500 cc (two required)	30	2.8 (6.0)	695475005	
Centering ring for ISO Inlet flange, 400K		0.5 (1.0)	IC400SV	
Centering ring for ISO foreline flange, 63K		0.5 (1.0)	IC063SV	
Instruction manual			699901023	
Replacement Parts (two heaters required per pump)				
2200 W, 208 V heater		1.0 (0.5)	647310140	
2200 W, 240 V heater		1.0 (0.5)	647310150	
2200 W, 380 V heater		1.0 (0.5)	647310160	
2200 W, 480 V heater		1.0 (0.5)	647310170	
2550 W, 208 V heater		1.0 (0.5)	647310145	
2550 W, 240 V heater		1.0 (0.5)	647310155	
2550 W, 380 V heater		1.0 (0.5)	647310165	
2550 W, 480 V heater		1.0 (0.5)	647310175	
Heater crush plate (one required per pump; replace when either heater is replaced)		2.0 (1.0)	K7667001	
Heater clamping plate (one required per pump)		1.0 (0.5)	R2667301	
Replacement nickel heater wire		1.0 (0.5)	656179100	
Replacement o-ring kit (kit contains: 1 inlet flange o-ring (butyl 2-385), foreline flange o-ring (butyl 2-338), sight glass o-ring and gasket, 10 fill and drain o-rings (Viton 2-113))		1.0 (0.5)	K0377189	
Thermal switch (set at 300° F – 147 °C)		1.0 (0.5)	642906025	

- NOTE**
- Inlet flange ISO 400K, foreline flange ISO 63-K.
 - Inlet flange non-standard ASA, foreline flange 2 in. ASA.
 - Pumps with ASA flanges include O-Rings for inlet and foreline flanges
 - Pumps with ISO flanges do not include centering rings required for inlet and foreline flanges.

HS-16

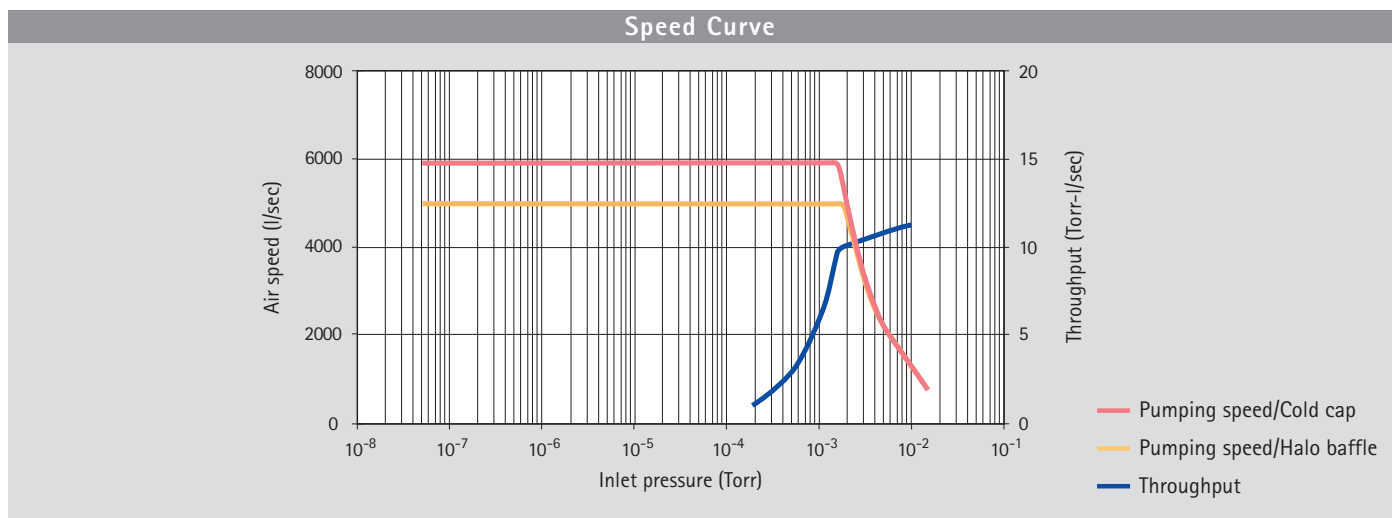
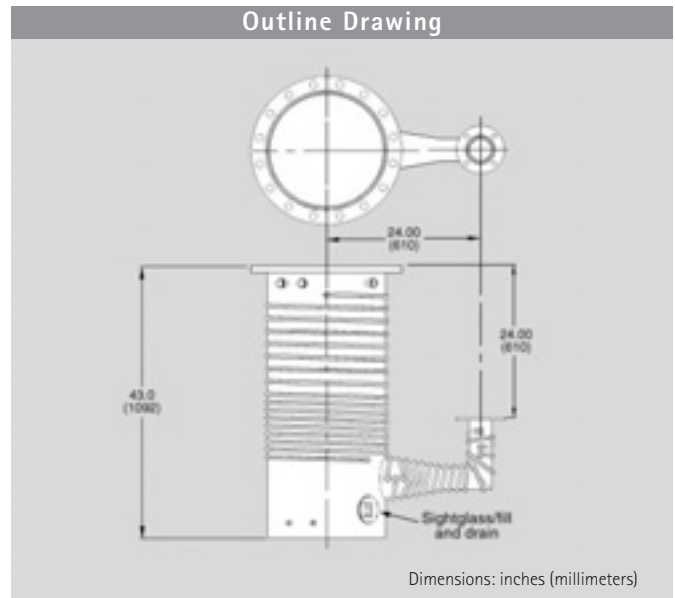

Technical Specifications

Pumping Speed, Operating Range	6,000 l/s air, 7,500 l/s He and H ₂	
Pumping Speed*, AVS 4.1 (1963)	10,000 l/s Air	
Maximum Throughput	8,100 W – 9.5 T-l/s (12.7 mbar l/s) in operating range 13.5 T-l/s (18.0 mbar-l/s) @ 0.01 torr	9,600 W – 12.0 T-l/s (16 mbar l/s) in operating range 11.5 T-l/s (15.3 mbar-l/s) @ 0.01 torr
Operating Range	2 x 10 ⁻³ to < 5 x 10 ⁻⁸ torr at 9,600 W (1.3 x 10 ⁻³ to < 6.5 x 10 ⁻⁸ mbar)	
Maximum Forepressure	No Load – 0.65 torr (0.85 mbar), Full Load – 0.55 torr (0.72 mbar)	
Pump Power	8100/9600 watts	
Recommended Backing Pump	≥ 80 cfm (136 m ³ /hr)	
Backstreaming Rate**, Standard Cold Cap	< 1.5 x 10 ⁻³ mg/cm ² /min	
Warmup Time	30 minutes	
Cooldown Time	48 minutes (30 minutes with optional quick cool coil)	
Fluid Charge	3 quarts (2.8 liters)	
Electrical Requirements	3 ph, 50/60 Hz, 240/415/480 VAC	
Cooling Water Requirements	1.5 gpm (300 l/hr) at 60–80° F (15–26 °C)	
Water Connections	1/4 in. FPT Tee	
Recommended Fluid	DC-704 (see page 30)	

22 *For an explanation of pumping speed measurements, please see page 36.

**Refer to page 34 for a description of test methods.

Ordering Information

Description	Voltage	Weight kg (lbs)	Part Number	
			Flange Type ASA	ISO
HS-16 Pump				
HS-16 with standard cold cap	240 V	218.0 (480.0)	79292308	L5921308
HS-16 with halo baffle	240 V	218.0 (480.0)	79292318	L5921318
HS-16 with standard cold cap	415 V	218.0 (480.0)	79292326	L5921326
HS-16 with halo baffle	415 V	218.0 (480.0)	79292336	L5921336
HS-16 with standard cold cap	480 V	218.0 (480.0)	79292309	L5921309
HS-16 with halo baffle	480 V	218.0 (480.0)	79292319	L5921319

NOTE • The HS-16 can be ordered with 9600 W heaters by increasing the middle number of the 3-digit suffix by two; eg 79292328

Accessories	Page	Weight kg (lbs)	Part Number
Water-cooled halo baffle	32	9.0 (20.0)	K0143316
Centering ring for ISO inlet flange, 500K		0.5 (1.0)	IC500SV
Centering ring for ISO foreline flange, 100K		0.5 (1.0)	IC100SV
Quick cool coil – must be installed in the factory			L6167301
Instruction manual			699901140

Replacement Parts (three heaters required per pump)

2700 W, 240 V/415 V with leads		0.5 (1.0)	647316020
2700 W, 480 V with leads		0.5 (1.0)	647316030
2700 W, 240 V/415 V no leads – used on pumps built before May '90		0.5 (1.0)	647316035
2700 W, 480 V no leads – used on pumps built before May '90		0.5 (1.0)	647316045
3200 W, 240 V/415 V with leads		0.5 (1.0)	647316023
3200 W, 480 V with leads		0.5 (1.0)	647316033
Heater crush plate (replace one with each new heater)		0.5 (1.0)	K4919001
Heater insulator (three required per pump)		0.5 (1.0)	79309001
Heater clamping plate (three required per pump)		4.0 (8.0)	K4917001
Replacement o-ring kit for ASA pumps (kit contains: 1 inlet flange o-ring (buna 48214001), 1 foreline flange o-ring (buna 2-348), sight glass o-ring and gasket, 8 fill and drain o-rings (Viton 2-213))		0.5 (1.0)	K0377164
Sight glass service kit (pumps built before Oct. '95)		1.5 (3.0)	F6097301
Upper (water) thermal switch (set at 185° F/85 °C)		0.5 (1.0)	K9050001
Lower (boiler) thermal switch (set at 390° F/199 °C)		0.5 (1.0)	K9050002
Cold cap gasket/grommet (kit of 4)		0.5 (1.0)	L8839301
Cold cap nut and follower (2 each)		0.5 (1.0)	L8840301

Heater Retrofit Kit (for pumps built before May '90; clamping plates not included)

HS-16, 240		25.0 (11.35)	L6526308
HS-16, 415		25.0 (11.35)	L6526326
HS-16, 480		25.0 (11.35)	L6526309

- NOTE**
- Inlet flange 16 in. ASA, foreline flange 3 in. ASA
 - Inlet flange ISO 500K, foreline flange ISO 100K
 - Not recommended for use with Santovac 5
 - Pumps with ASA flanges include o-rings for inlet and foreline flanges
 - Pumps with ISO flanges do not include centering rings required for foreline and inlet flanges

HS-20

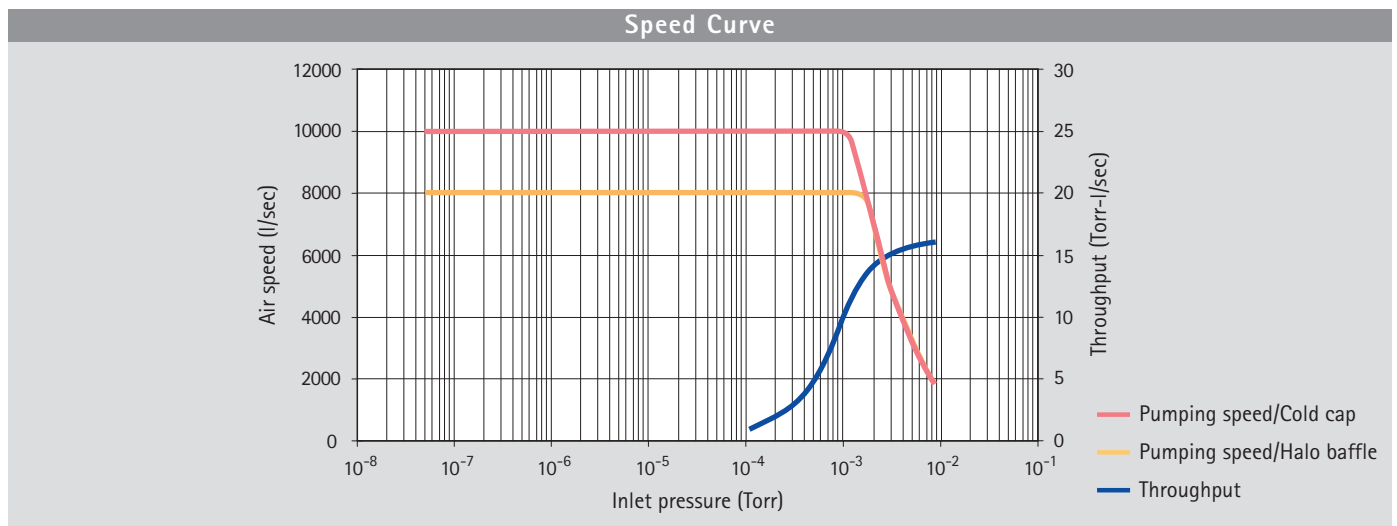
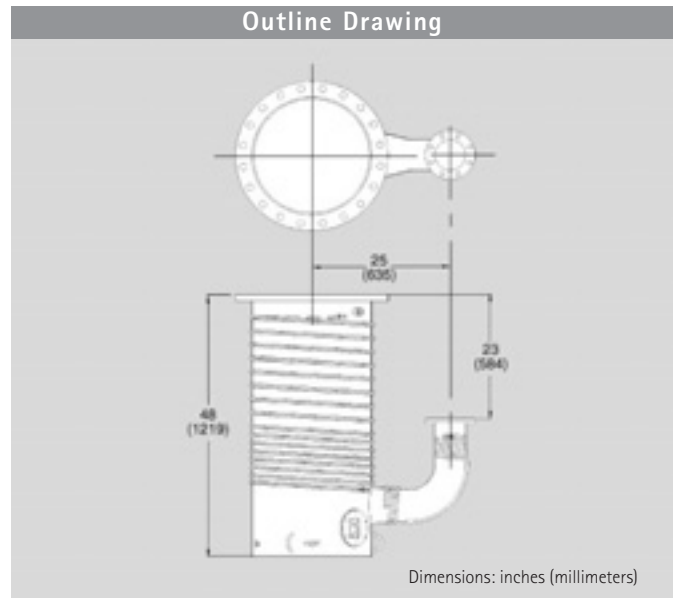

Technical Specifications

Pumping Speed, Operating Range	10,000 l/s air, 12,500 l/s He and H ₂
Pumping Speed*, AVS 4.1 (1963)	17,500 l/s Air
Maximum Throughput	12.5 T-l/s (16.7 mbar l/s) in operating range, 18 T-l/s (23 mbar-l/s) @ 0.01 torr
Operating Range	1.3 x 10 ⁻³ to 5 x 10 ⁻⁸ torr (1.7 x 10 ⁻³ to 6.5 x 10 ⁻⁸ mbar)
Maximum Forepressure	No Load: 0.65 torr (0.85 mbar) Full Load: 0.55 torr (0.72 mbar)
Recommended Backing Pump	≥ 100 cfm (170 m ³ /hr)
Backstreaming Rate**, Standard Cold Cap	< 1.5 x 10 ⁻³ mg/cm ² /min
Warmup Time	45 minutes
Cooldown Time	85 minutes
Fluid Charge	5 quarts (4.7 liters)
Electrical Requirements	3 ph, 50/60 Hz, 240/415/480 VAC
Pump Power	12,000 watts
Cooling Water Requirements	1.5 gpm (300 l/hr) at 60-80° F (15-26 °C)
Water Connections	1/4 in. FPT Tee
Recommended Fluid	DC-704 (see page 30)

24 *For an explanation of pumping speed measurements, please see page 36.

**Refer to page 34 for a description of test methods.

Ordering Information

Description	Voltage	Weight kg (lbs)	Part Number	
			Flange Type ASA	ISO
HS-20 Pump				
HS-20 with standard cold cap	240 V	264.0 (580.0)	84341308	L5922308
HS-20 with halo baffle	240 V	264.0 (580.0)	84341318	L5922318
HS-20 with standard cold cap	415 V	264.0 (580.0)	84341326	L5922326
HS-20 with halo baffle	415 V	264.0 (580.0)	84341336	L5922336
HS-20 with standard cold cap	480 V	264.0 (580.0)	84341309	L5922309
HS-20 with halo baffle	480 V	264.0 (580.0)	84341319	L5922319
Accessories				
Water-cooled halo baffle	Page 32	Weight kg (lbs) 11.0 (25.0)	Part Number K1855320	
Centering ring for ISO foreline flange, 160K		0.5 (1.0)	IC160SV	
Quick cool coil – must be installed in the factory			84884001	
Instruction manual			699901140	
Replacement Part (six heaters required per pump)				
Heater, 2000 W, 240 V/415 V with leads		0.5 (1.0)	647320020	
Heater, 2000 W, 480 V with leads		0.5 (1.0)	647320030	
Heater, 2000 W, 240 V/415 V no leads – used on pumps built before May '90		0.5 (1.0)	647320060	
Heater, 2000 W, 480 V no leads – used on pumps built before May '90		0.5 (1.0)	647320070	
Heater crush plate (replace one with each new heater)		0.5 (1.0)	K7108001	
Heater clamping plate (six required per pump)		4.0 (8.0)	K7107001	
Heater insulator (one required per pump)		0.5 (1.0)	L6514001	
Replacement o-ring kit for ASA pumps (kit contains 1 inlet flange o-ring (butyl 84349002), 1 foreline flange o-ring (buna 2-432), sight glass o-ring and gasket, 8 fill and drain o-rings (Viton 2-213))		0.5 (1.0)	K0377165	
Sight glass service kit (pumps built before Oct. '95)		1.5 (3.0)	F6097301	
Upper (water) thermal switch (set at 185° F/85 °C)		0.5 (1.0)	K9050001	
Lower (boiler) thermal switch (set at 390° F/199 °C)		0.5 (1.0)	K9050002	
Cold cap gasket/grommet (kit of 4)		0.5 (1.0)	L8839301	
Cold cap nut and follower (2 each)		0.5 (1.0)	L8840301	
Heater Retrofit Kit (for pumps built before May '90; clamping plates not included)			K7107001	
HS-20, 240		13.62 (30.0)	L6392308	
HS-20, 415		13.62 (30.0)	L6392326	
HS-20, 480		13.62 (30.0)	L6392309	

- NOTE**
- Inlet flange 20 in. ASA, foreline flange 4 in. ASA
 - Inlet flange ISO 630K, foreline flange ISO 160K
 - Not recommended for use with Santovac 5
 - Pumps with ASA flanges include o-rings for inlet and foreline flanges
 - Pumps with ISO flanges do not include centering rings required for foreline and inlet flanges

Please note that this item is controlled for export by the Nuclear Suppliers Group. Accordingly, you may be required to obtain an export license from the U.S. Department of Commerce prior to exporting this diffusion pump from the United States. Please consult the U.S. Export Administration Regulations, ECCN 2B231, for further guidance.

HS-32

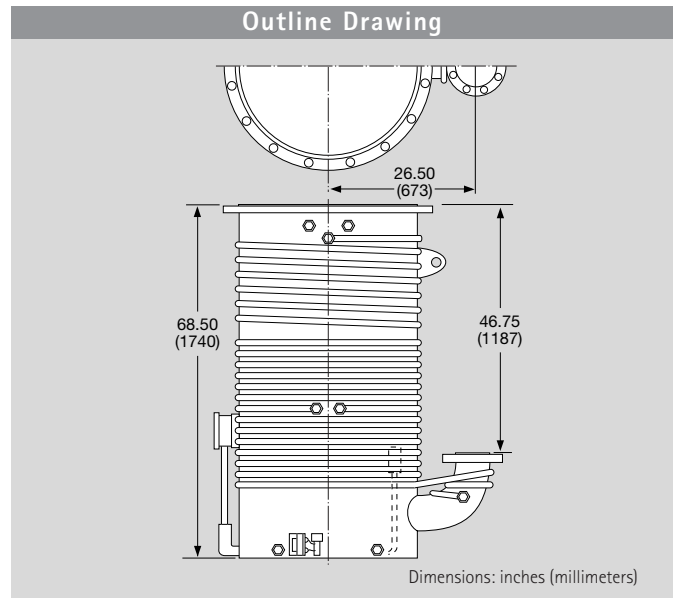

Technical Specifications

Pumping Speed, Operating Range	17,300 l/s Air, 21,625 l/s He and H ₂
Pumping Speed*, AVS 4.1 (1963)	32,000 l/s Air
Maximum Throughput	30 T-l/s (40 mbar l/s) in operating range, 35 T-l/s (45 mbar-l/s) @ 0.01 torr
Operating Range	1.7×10^{-3} to $< 5 \times 10^{-8}$ torr (2.3×10^{-3} to $< 6.5 \times 10^{-8}$ mbar)
Maximum Forepressure	No Load: 0.50 torr (0.65 mbar) Full Load: 0.35 torr (0.45 mbar)
Recommended Backing Pump	≥ 300 cfm (510 m ³ /hr)
Backstreaming Rate**, Standard Cold Cap	$< 7 \times 10^{-4}$ mg/cm ² /min
Warmup Time	60 minutes
Cooldown Time	180 minutes
Fluid Charge	3 U.S. gallons (11.3 liters)
Electrical Requirements	3 ph, 50/60 Hz, 240/415/480 VAC
Pump Power	24,000 watts
Cooling Water Requirements	4 gpm (800 l/hr) at 60-80 °F (15-26 °C)
Water Connections	3/8 in. FPT Tee
Recommended Fluid	DC-704 (see page 30)

*For an explanation of pumping speed measurements, please see page 36.

**Refer to page 34 for a description of test methods.

Speed Curve

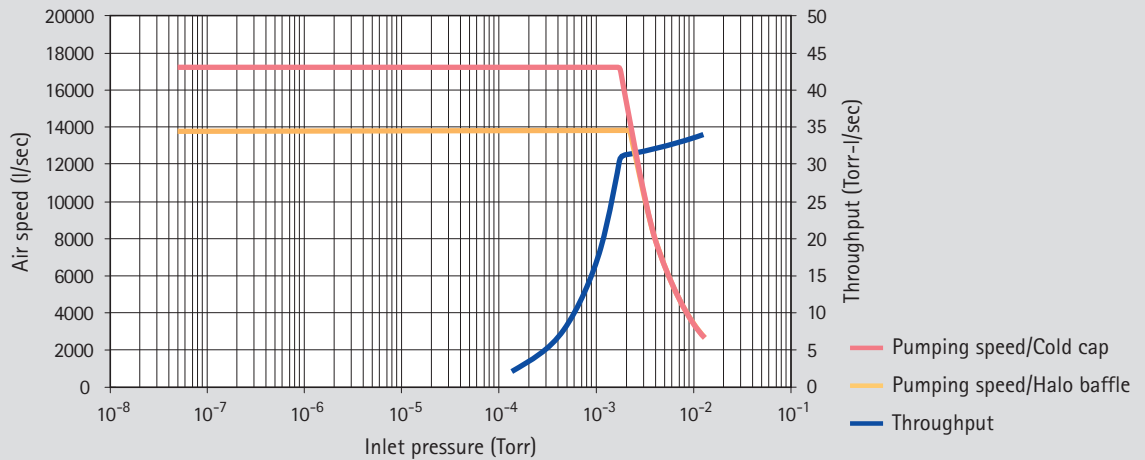

Diffusion Pumps

Ordering Information

Description	Wt. kg (lbs)	Part Number	
HS-32 Pump		ASA	ISO
HS-32 with standard cold cap, 240 V	612 (1,350)	76134308	L5923308
HS-32 with halo baffle, 240 V	612 (1,350)	76134318	L5923318
HS-32 with standard cold cap, 415 V	612 (1,350)	76134326	L5923326
HS-32 with halo baffle, 415 V	612 (1,350)	76134336	L5923336
HS-32 with standard cold cap, 480 V	612 (1,350)	76134309	L5923309
HS-32 with halo baffle, 480 V	612 (1,350)	76134319	L5923319

Accessories	Wt. kg (lbs)	Part Number
Water-cooled halo baffle	16 (35)	K1856332
Quick cool coil – must be installed in the factory		K6175001
Centering ring for ISO foreline flange, 200K	0.5 (1.0)	IC200SV
Instruction manual		699901140

- NOTE**
- Inlet flange 32 in. ASA, foreline flange 6 in. ASA
 - Inlet flange ISO 800F (bolted), foreline flange ISO 200K (clamped)
 - Not recommended for use with Santovac 5
 - ASA pump versions include o-rings for both inlet and foreline flanges
 - ISO pump versions include inlet flange o-ring, but does not include foreline flange centering ring

Please note that this item is controlled for export by the Nuclear Suppliers Group. Accordingly, you may be required to obtain an export license from the U.S. Department of Commerce prior to exporting this diffusion pump from the United States. Please consult the U.S. Export Administration Regulations, ECCN 2B231, for further guidance.

Description	Wt. kg (lbs)	Part Number
Replacement Parts (six heaters required per pump)		
Heater*, 4000 W, 240 V/415 V/480 V with leads	0.5 (1.0)	647332010
Heater*, 4000 W, 240 V/415 V/480 V no leads – used on pumps built before May '90	0.5 (1.0)	647332075
*One heater consists of 2-120V heaters, right and left		
Heater crush plate (replace one with each new heater)	0.5 (1.0)	K7246001
Heater insulator (one required per pump)	0.5 (1.0)	75792001
Heater clamping plate (six required per pump)	4 (8)	K7247001
Replacement o-ring kit for ASA pumps (kit contains: 1 inlet flange o-ring (buna 45390001), 1 foreline flange o-ring (butyl 2-443), sight glass o-ring and gasket, 8 fill and drain o-rings (Viton 2-213))	0.5 (1.0)	K0377167
Sight glass service kit (pumps built before Oct. '95)	1.5 (3.0)	F6097301
ISO inlet flange o-ring	0.5 (1.0)	78536002
Upper (water) thermal switch (set at 550° F/288 °C)	0.5 (1.0)	K9050005
Lower (boiler) thermal switch (set at 220° F/104 °C)	0.5 (1.0)	K9050004
Cold cap gasket/grommet (kit of 4)	0.5 (1.0)	L8839301
Cold cap nut and follower (2 each)	0.5 (1.0)	L8840301

Heater Retrofit Kit (for pumps built before May '90; clamping plates not included)

HS-32, 240	18.16 (40.0)	L6517308
HS-32, 415	18.16 (40.0)	L6517326
HS-32, 480	18.16 (40.0)	L6517309

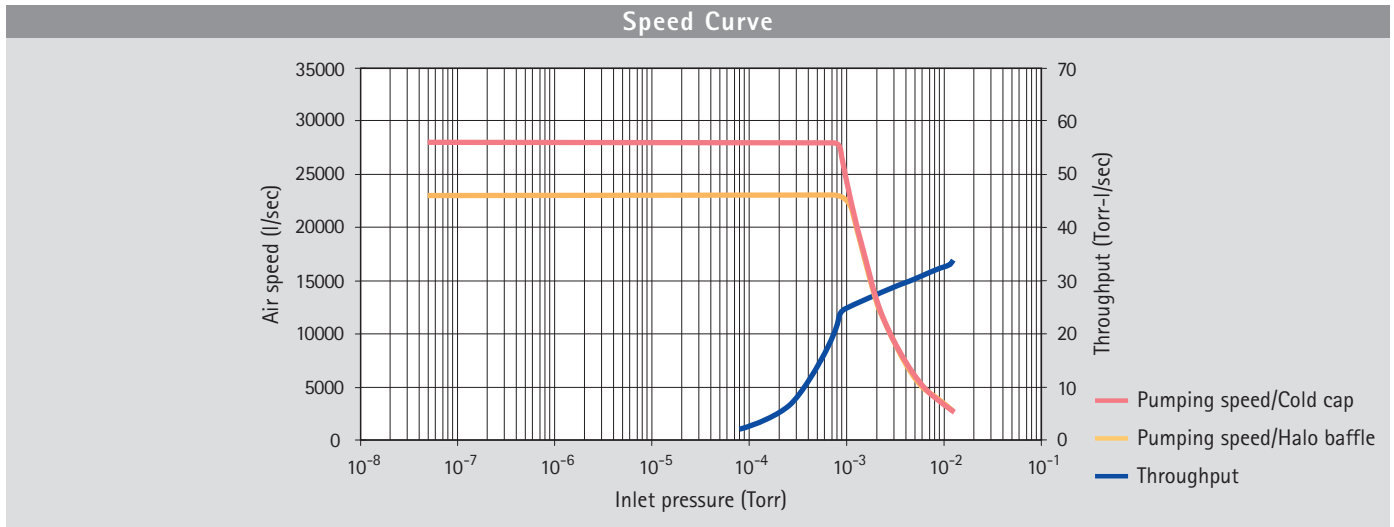
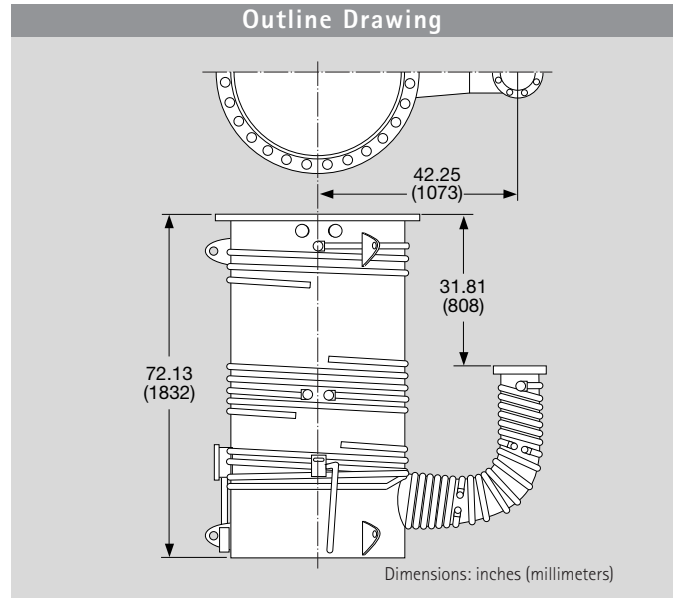

Technical Specifications

Pumping Speed, Operating Range	28,000 l/s air, 35,000 l/s He and H ₂
Pumping Speed*, AVS 4.1 (1963)	50,000 l/s Air
Maximum Throughput	25 T-l/s (33 mbar l/s) in operating range, 35 T-l/s (45 mbar-l/s) @ 0.01 torr
Operating Range	9×10^{-4} to $< 5 \times 10^{-8}$ torr (1.2×10^{-3} < 6.5×10^{-8} mbar)
Maximum Forepressure	No Load - 0.55 torr (0.71 mbar), Full Load - 0.40 torr (0.52 mbar)
Recommended Backing Pump	≥ 300 cfm (510 m ³ /hr)
Backstreaming Rate**, Standard Cold Cap	$< 5 \times 10^{-4}$ mg/cm ² /min
Warmup Time	60 minutes
Cooldown Time	180 minutes
Fluid Charge	3 U.S. gallons (11.3 liters)
Electrical Requirements	3 ph, 50/60 Hz, 240/415/480 VAC
Pump Power	24,000 watts
Cooling Water Requirements	4 gpm (800 l/hr) at 60-80 °F (15-26 °C)
Recommended Fluid	DC-704 (see page 30)

*For an explanation of pumping speed measurements, please see page 36.

**Refer to page 34 for a description of test methods.

Ordering Information

Description	Voltage	Weight kg (lbs)	Part Number	
			Flange Type ASA	ISO
HS-35 Pump				
NHS-35 with standard cold cap	240 V	680.0 (1,550.0)	F1730308	L5924308
NHS-35 with halo baffle	240 V	680.0 (1,550.0)	F1730318	L5924318
NHS-35 with standard cold cap	415 V	680.0 (1,550.0)	F1730326	L5924326
NHS-35 with halo baffle	415 V	680.0 (1,550.0)	F1730336	L5924336
NHS-35 with standard cold cap	480 V	680.0 (1,550.0)	F1730309	L5924309
NHS-35 with halo baffle	480 V	680.0 (1,550.0)	F1730319	L5924319
Accessories				
	Page	Weight kg (lbs)	Part Number	
Water-cooled halo baffle	32	20.0 (45.0)	K1857335	
Quick cool coil – must be installed in the factory, can not ship separately			F1739001	
Centering ring for ISO foreline flange, 200K		0.5 (1.0)	IC200SV	
O-ring, ISO Inlet flange		0.5 (1.0)	78536002	
Instruction manual			699901140	
Replacement Parts (six heaters required per pump)				
Heater 4000 W, 240 V/480 V with leads		0.5 (1.0)	647335010	
Heater 4000 W, 240 V/480 V no leads – used on pumps built before May '90		0.5 (1.0)	647235248	
Heater, 4000 W, 200 V		0.5 (1.0)	647335020	
Heater, 4000 W, 400 V		0.5 (1.0)	L6383010	
Heater, 4000 W, 440 V		0.5 (1.0)	L6383011	
Heat shield (reusable)		0.5 (1.0)	L6370001	
Heater clamping plate (six required per pump)		4.0 (8.0)	F1749001	
Heater insulator (one required per pump)		0.5 (1.0)	L9699001	
Replacement o-ring kit for ASA pumps (kit contains: 1 inlet flange o-ring (buna 78536001), 1 foreline flange o-ring (butyl 2-267), sight glass o-ring and gasket, 8 fill and drain o-rings (Viton 2-213))		0.5 (1.0)	K0377169	
Sightglass service kit (pumps built before Oct. '95)		1.5 (3.0)	F6097301	
Upper (water) thermal switch (set at 200° F/93 °C)		0.5 (1.0)	K9050005	
Lower (boiler) thermal switch (set at 600° F/316 °C)		0.5 (1.0)	K9050006	
Cold cap gasket/grommet (kit of 4)		0.5 (1.0)	L8839301	
Cold cap nut and follower (2 each)		0.5 (1.0)	L8840301	
Heater Retrofit Kit (for pumps built before May '90; clamping plates not included)				
NHS-35, 240/400/440		18.16 (40.0)	L6391308	
NHS-35, 415		18.16 (40.0)	L6391326	
NHS-35, 480		18.16 (40.0)	L6391309	

- NOTE**
- Inlet flange 35 in. ASA, foreline flange 6 in. ASA
 - Inlet flange ISO 1000F (bolted), foreline flange ISO 200K (clamped)
 - Not recommended for use with Santovac 5
 - ASA pump versions include o-rings for both inlet and foreline flanges
 - ISO pump versions include inlet flange o-ring, but does not include foreline flange centering ring

Please note that this item is controlled for export by the Nuclear Suppliers Group. Accordingly, you may be required to obtain an export license from the U.S. Department of Commerce prior to exporting this diffusion pump from the United States. Please consult the U.S. Export Administration Regulations, ECCN 2B231, for further guidance.

Diffusion Pump Fluids

Varian offers a wide range of diffusion pump fluid types and containers sizes. We have just the right fluid type and container size to meet the requirements of your particular application.

	NEOVAC SY	DC-702	DC-704	DC-705	SANTOVAC 5*
Chemical description	Synthetic Hydrocarbon	Silicone	Single-Component Silicone	High-Purity Silicone	Mixed 5-Ring Polyphenyl Ether
Chemical composition	Mono-N Alkyldiphenylether	Mixed Phenylmethyldimethyl Cyclosiloxane	Tetramethyltetra-phenyltrisiloxane	Penta phenyltri-methyltrisiloxane	Mixed 5-Ring Polyphenyl Ether
Ultimate pressure Untrapped (torr)	Low 10 ⁻⁸ Range	10 ⁻⁶	10 ⁻⁷ to 10 ⁻⁸ range	10 ⁻⁹ to 10 ⁻¹⁰ range	10 ⁻¹⁰
Trapped (torr)	1 x 10 ⁻¹¹ Range	-	to 10 ⁻¹¹ range	10 ⁻¹¹ range	-
Vapor pressure at 25 °C (torr)	1 x 10 ⁻⁸	1 x 10 ⁻⁶	2 x 10 ⁻⁸	3 x 10 ⁻¹⁰	1 x 10 ⁻⁹ at 20 °C
Viscosity (cst) at 25 °C	25 at 40 °C	45	39	175	2400
Average molecular weight	405	-	484	546	446
Boiling temperature (°C) at 0.5 torr	220 at 0.8 torr	180	215	245	275
Flash point	230	193	221	243	288
Ultimate pressure	Very Good	Fair	Very Good	Excellent	Excellent
Thermal stability	Good	Excellent	Excellent	Excellent	Very Good
Oxidation resistance	Good	Excellent	Excellent	Excellent	Very Good
System cleanliness	Very Good	Good	Very Good	Very Good	Excellent

NOTE • Santovac 5 is the only recommended fluid for leak detectors

NEOVAC SY is a high quality, low cost synthetic organic compound (alkyldiphenylether) that performs as well as DC-704. With its low vapor pressure, it will achieve base pressures in the low 10⁻⁸ torr range untrapped and will not produce inorganic deposits which can cause electrostatic charge buildup on electrodes of sensitive instruments.

Dow Corning DC-702 is an all-purpose silicone fluid that is capable of achieving pressures of 10⁻⁷ torr range. With lower boiling points than DC 704 and DC 705, it gives higher throughput for a given power.

Dow Corning DC-704 is a single component silicone fluid that will achieve pressures in the low 10⁻⁸ torr range untrapped. With its low vapor pressure, it combines very good pumping characteristics with low Backstreaming Rates.

Dow Corning DC-705 is a high-purity, single component silicone fluid designed for ultrahigh vacuum applications. It can achieve pressures in the low 10⁻¹⁰ torr range untrapped. The vapor pressure and backstreaming rate of this fluid is so low that the use of traps and baffles is often unnecessary.

Santovac 5 is a five-ring polyphenylether for use in ultrahigh vacuum applications. With ultra low vapor pressure and backstreaming rates, this fluid is very clean and often eliminates the need for traps and baffles. Ultimate pressures in the 10⁻¹⁰ torr range can be achieved and will not produce inorganic deposits which can cause electrostatic charge buildup on electrodes of sensitive instruments.

Ordering Information

Description	Diffusion Pump Exact Charge	Weight kg (lbs)	Part Number
NEOVAC SY			
1 liter/1,000 cc	VHS-10, VHS-400	3.0 (1.4)	K6948301
U.S. gallon (3.8 liters)		10.6 (4.8)	K6948305
5 U.S. gallons (18.9 liters)		53.0 (23.9)	K6948315
Dow Corning DC-702			
500 cc	VHS-6, VHS-250	3.0 (1.4)	695472005
1 U.S. gallon (3.8 liters)		12.0 (5.4)	695472008
5 U.S. gallons (18.9 liters)		51.0 (23.0)	695472015
Dow Corning DC-704			
500 cc	VHS-6, VHS-250	3.0 (1.4)	695474005
1 U.S. gallon (3.8 liters)		12.0 (5.4)	695474008
6.2 U.S. gallons (23.5 liters)		51.0 (23.0)	695474015
Dow Corning DC-705			
500 cc	VHS-6, VHS-250	3.0 (1.4)	695475005
1 U.S. gallon (3.8 liters)		12.0 (5.4)	695475008
Santovac 5			
40 cc		1.0 (0.5)	695405001
65 cc		2.0 (0.9)	695405002
500 cc	VHS-6, VHS-250	2.5 (1.1)	695405005

Water-Cooled Baffles



Pump Model

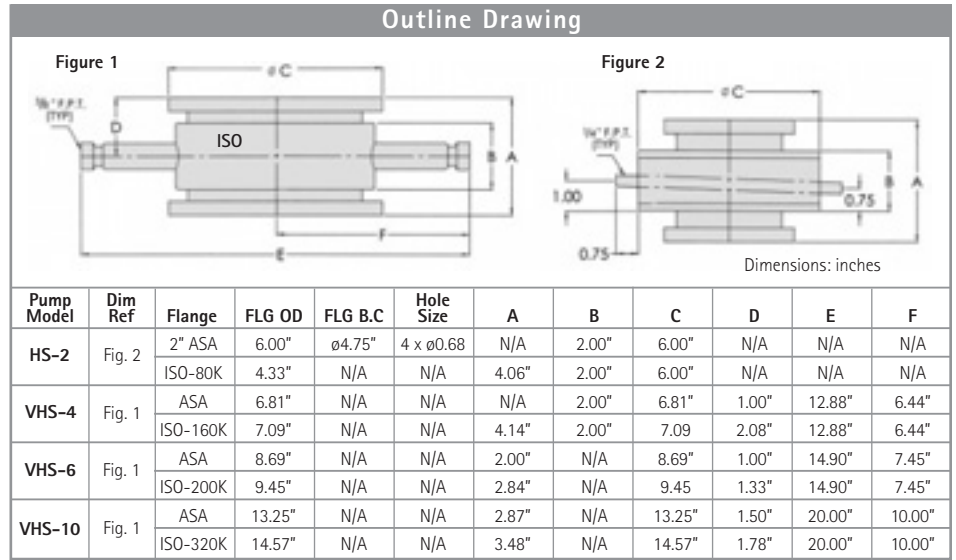

Optically dense, water cooled baffles are available for Varian's HS-2, VHS-4, VHS-6 and VHS-10 diffusion pumps. These baffles should be used in applications where the backstreaming must be kept to extremely low values beyond the performance of the extended cold cap. The baffles are designed to intercept 100% of primary backstreaming while retaining 50%

of the diffusion pump speed. Use either chilled water or mechanical refrigeration to achieve the desired backstreaming performance. When using the water cooled baffle, configure your diffusion pump with the standard cold cap.

Technical Specifications and Ordering Information					
Pump Model/ Size	Nominal Conductance	Recommended Flow	Flange Type	Weight kg (lbs)	Part Number
HS-2	300 l/s (air)	0.1 To 0.2 gpm (20-40 l/hr)	ASA	4.5 (10.0)	F9453302
			ISO	4.5 (10.0)	F9453303
VHS-4	900 l/s (air)	0.1 To 0.2 gpm (20-40 l/hr)	ASA	4.5 (10.0)	F8286304
			ISO	4.5 (10.0)	F8286305
VHS-6	1500 l/s (air)	0.1 To 0.2 gpm (20-40 l/hr)	ASA	7.0 (15.0)	F8277306
			ISO	7.0 (15.0)	F8277307
VHS-10	3550 l/s (air)	0.1 To 0.2 gpm (20-40 l/hr)	ASA	9.0 (20.0)	F8600310
			ISO	9.0 (20.0)	F8600311

Extended Cold Caps for VHS-4, -6, and -10 Diffusion Pumps



The Extended Cold Cap is an option that fits inside the VHS-4, VHS-6, and VHS-10 pumps in place of the standard cold cap. It stops backstreaming as effectively as an optically dense baffle, yet it retains 80% of the pump's speed. Residual backstreaming is so low that it cannot be measured by the American Vacuum Society's standard collection method.

Technical Specifications

Speed with Extended Cold Cap	≈ 80% of pump speed
Materials	Nickel-plated copper
Cooling	Conduction (no water)

Ordering Information

Description	Weight kg (lbs)	Part Number
VHS-4	0.5 (1.0)	F6898301
VHS-6	0.5 (1.0)	F6455001
VHS-10	0.9 (2.0)	L8917301

Halo Baffles for Large Diffusion Pumps for HS-16, -20, -32 and NHS-35 Diffusion Pumps



Varian's Halo Baffles provide nearly twice the speed at the pump inlet as that achieved with conventional chevron baffles, while adding no height to the system. These water-cooled baffles are very economical compared to other opaque chevron baffles.

Technical Specifications

Net Speed with Halo Baffle	Approximately 60% of pump speed*
Backstreaming Reduction	Approximately 90%*
Materials	Nickel-plated copper (16 in., 20 in.) Nickel-plated mild steel (32 in., 35 in.)
Cooling: Recommended Water Flow	In series with diffusion pumps; see specific diffusion pump technical specs HS16 – NHS-35

Ordering Information

Baffle Size	Weight kg (lbs)	Part Number
16 in.	9.0 (20.0)	K0143316
20 in.	11.0 (25.0)	K1855320
32 in.	16.0 (35.0)	K1856332
35 in.	20.0 (45.0)	K1857335

*Values are estimates. Actual speed and backstreaming rate will vary depending on the application conditions.

Technical Notes

Diffusion pumps were first conceived and constructed by W. Gaede (1915-Germany) and I. Langmuir (1916-U.S.A). They operate on the principle of transferring momentum from high velocity vapor molecules to the gas molecules that are to be moved out of the system. The vapor molecules are formed by heating a suitable condensable fluid. The early pumps used mercury for this purpose.

In the late 1920s, C.R. Burch (England) and K.C. Hickman (U.S.A.) found that certain high molecular weight oils having high boiling points and low vapor pressures could be used as pumping fluids. These oils were useful because they remained in the pump indefinitely and allowed lower pressures to be attained without the use of a cold trap (see section on Baffles and Traps). Today, with the exception of a few isolated applications like some analytical instruments, all diffusion pumps use some form of oil. For additional information in this area, see the discussion on pumping fluids below.

As industrial and scientific requirements for rarefied atmospheres increased, research and development into the nature and production of high vacuum increased. By the early 1940s, a well-developed vacuum technology existed and was intensified both during World War II and by the space effort of the 1960s. Engineering has continued in the vacuum field, and in 1965 Varian's M.H. Hablanian, et al. made a significant contribution to diffusion pump design that markedly increased pumping speeds.

Applications

Due to its simplicity, high performance, and low initial cost, the diffusion pump remains a primary industrial high vacuum pumping mechanism. Applications for this type of pump are found in such diverse areas as:

1. Analytical instruments
2. Coating, functional
3. Coating, ornamental
4. Electron tube manufacture
5. Metallurgy
6. Optics
7. Outer space simulation
8. Particle accelerators
9. Petrochemicals
10. Pharmaceuticals
11. R&D laboratories
12. Semiconductor manufacture

Used in combination with the proper choice of motive fluids, traps, baffles, and valves, diffusion pumps can be used in a wide variety of applications and over pressure ranges from 1×10^{-3} torr to 2×10^{-11} torr.

Basic Performance Factors

1. **Pumping speed** is volume per unit time. It is generally specified in liters/second and is an important parameter in determining the ultimate pressure of a system. This is

expressed by the relationship

$$Q = PS$$

Where:

- Q is the system gas load in torr-liters/second
 - P is the attainable pressure in torr
 - S is the effective pump speed at the system
- "Q" is the total leakage of the system which includes vapors given off by dirt and outgassing of internal surfaces as well as holes to the outside world. Ultimate pressure is also affected by such factors as the compression ratio for light gases and the nature of the pumping fluid.
2. **Maximum throughput** is the pump's maximum gas mass transfer capability – pressure x volume per unit time. It is generally specified in torr-liters/second or mbar l/s.
 3. **Tolerable forepressure** is the maximum allowable pressure in the foreline. It is maintained at or below this value by a suitably-sized mechanical foreline (backing) pump. If this pressure increases above that specified for a given pump, gas will diffuse back through the pump and pumping will stop. It should be noted that the size of this mechanical pump can affect the maximum throughput value.
 4. **Backstreaming rate** is the rate at which the pumping fluid vapor leaves the inlet opening of the pump, moving back in the direction of the system being pumped. It is measured in milligrams per cm^2 per unit time and will vary with the type of motive fluid employed.

Operation

Diffusion pumps are vapor jet pumps that work on the basis of momentum transfer from a heavy high speed vapor molecule to a gas molecule. This results in the gas molecules being moved through the pump.

In Figure 1, the bottom of the pump contains an electric heater that is used to produce the vapor by heating the pumping (motive) fluid to its boiling point at reduced pressure.

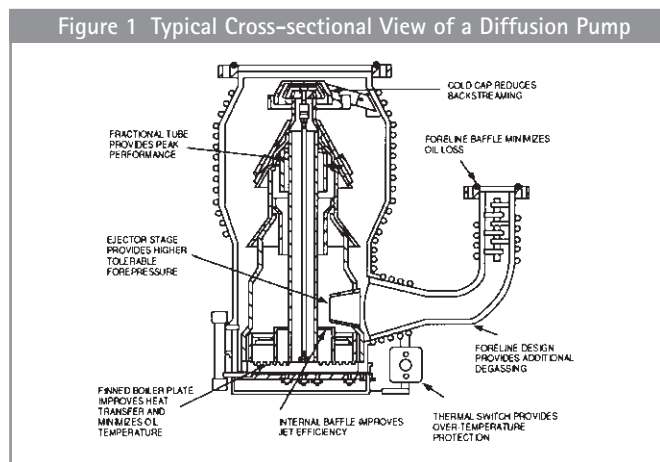

This means that before the pump is started, it must be "rough pumped" down to and held at an acceptable pressure, typically 10^{-1} torr. (For information on rough pumping, see section on Primary Pumps.) To do otherwise will result in no pumping action and possible damage to the pumping fluids. Once boiling of the fluid has begun, the vapor is forced up the central columns of the jet assembly. It then exits at each downward-directed jet in the form of a molecular curtain that impacts the water-cooled pump body. Here, the vapor condenses and runs back down to the boiler. This refluxing action continues as long as proper heat and forepressure are maintained.

As gas molecules from the system randomly enter the pump (molecular flow conditions), they encounter the top jet. Some of them are correctly impacted and driven on to the next jet. Subsequently, they reach the foreline where they are exhausted to the atmosphere by the mechanical backing pump.

The diffusion pump is similar in character to other compression pumps in that it develops a relatively high exhaust pressure compared to the inlet pressure. This compression ratio for an inlet pressure of 2×10^{-7} torr and a foreline pressure of 2×10^{-1} would be ten million to one for most gases. Figure 2 shows how the pumping speed varies with pressure. Note that the speed remains constant from the 10^{-3} torr scale to the X^{-10} torr scale and then falls off as a result of the compression ratio for hydrogen and helium plus the vapor pressure contribution of the pumping fluid.

In the same way that the pump must be rough pumped before starting, so must the system to be evacuated by rough pumping prior to exposure to the pump. Exposing a hot pump

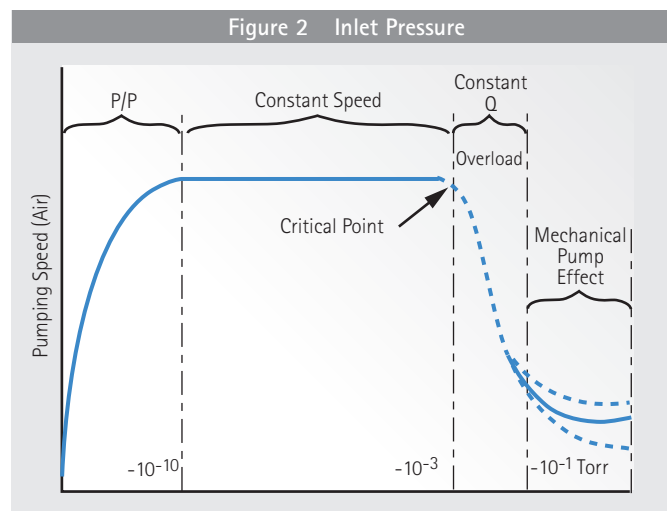

Typical plot of diffusion pump performance. Four regions are evident: 1) Effect of the pressure ratio limit; 2) Normal operating range with constant speed; 3) Throughput limited condition; 4) Effect of backing pump.

to a rush of air at atmospheric pressure could be catastrophic for the equipment and possibly explosive, depending upon the pump fluid being used. For further information in this

area, see the discussion on pumping fluids, below, and the section on valves.

Design Features

Design features unique to Varian diffusion pumps provide positive benefits to the customer, such as:

1. Varian oil diffusion pumps incorporate an ejector stage as well as the full fractionation jets. This feature assures the user of constantly purified pumping fluid and the capability of maintaining low pressures.
2. Varian oil diffusion pumps incorporate insulated jet drip shields which prevent re-boiling of oil droplets outside the jet assembly. This feature assures the user of the lowest backstreaming rates attainable.
3. Varian water cooling coils are attached by a proprietary weld/brace technique. This special technique means excellent thermal contact and no chance for coils to "melt" away from the pump body in cases of accidental overheating.
4. Varian pumps incorporate a water-cooled cold cap that reduces 98 percent of the backstreaming common to most diffusion pumps and the user is assured of a cleaner system.
5. Varian water-cooled pumps incorporate the quick cool boiler coils, allowing faster shutdown of the system with no damage to the oil.
6. Varian pumps use standard ASA flanges. This feature permits wide flexibility formatting with systems and other hardware.
7. Varian (4-inch and larger) pumps have a thermal protection switch as a standard feature. This device prevents damage to the pump and surroundings due to overheating.

Pumping Fluids

In an oil diffusion pump, high speed heated oil vapor provides the kinetic energy that moves gas molecules to the foreline and prevents their back-migration. These oils may be derived from a petroleum base but more typically are synthesized from phthalates, sebacates, phenyl groups, or siloxanes.

To be an effective pumping fluid, the compound must have a relatively high molecular weight and a low vapor pressure at elevated temperatures. Other desirable properties are inertness and stability in order to resist chemical reaction and disintegration into undesirable fractions.

Phenyl ethers such as Neovac-SY and Santovac-5 are fairly resistant to oxidation and are used successfully around electronic devices. These oils polymerize into a conducting film when bombarded with electrons and thus do not promote static charge build-up. In addition, they are quite soluble and "clean up" easily. Neovac-SY has the advantage of economy while Santovac-5 is more durable and has a lower vapor pressure.

Technical Notes

For additional oxidation resistance, many applications lend themselves to the use of silicone fluids. These are phenyl siloxane compounds that polymerize as a non-conducting film that can allow static charge buildup and are difficult to "clean up". Two common fluids of this type are DC-704 and DC-705; the former has four phenyl groups and the latter has five. The DC-705 is, therefore, a heavier molecule, and it has a lower vapor pressure, so it is highly suitable for achieving very low pressures. However, it is somewhat less effective under high throughput conditions than DC-704, due to the fact that fewer molecules emerge from the top jet.

Another extremely stable fluid under reactive conditions is the fluorinated polyphenyl ether (Fomblin® or Krytox). This oil is widely used in mechanical oil-sealed pumps where large amounts of oxygen are pumped. It is also suitable as a diffusion pump fluid where large quantities of oxygen or other reactive gases may be encountered.

Speed Measurements

Note: *The speed values in this catalog have been measured according to ISO Standard 1608/1. They differ from the values published in previous catalog editions strictly due to the change in testing methods. The design and performance of the pumps have not changed in any way – only the speed test method.*

For reference, the speed values from the previous catalog editions are included in the technical specifications table for each pump. The data is labeled "Pumping Speed", AVS 4.1 (1963).

The pressure gage mounted in the test dome is located at a distance of 1/2 the diameter of the pump from the inlet plane, versus 1/4 the diameter in previous tests. Also, total pressure gages were used to measure the pressure and calculate speed, versus partial pressure gages.

Combined, these two changes in test method result in a measured speed approximately 40% lower than previously published values. The changes in test method do not affect maximum throughput measurements.

Pumping speed is measured by introducing a known, steady state flow of gas into a measuring dome of specified geometry and measuring the resulting pressure established in the dome. Figure 1 shows the experimental setup used by Varian as recommended by the American Vacuum Society (Standard 4.1). Speed is determined by the AVS Standard as:

$$S = Q / (P - P_0),$$

where Q is the flow rate (throughput) and P₀ is the ultimate pressure prior to the experiment. All diffusion pump curves shown in the catalog are based on the use of DC704 diffusion pump fluid and the standard cold cap (unless otherwise noted). The speed curves are created by calculating the speed

at increasing levels of gas throughput, allowing time between readings to ensure steady state conditions are reached.

Diffusion pumps exhibit different speeds for different gases. Thus, the speed of each gas is obtained by dividing the throughput of the gas by the partial pressure of the same gas in the dome. Unless otherwise noted, the speeds shown in this catalog are for air.

Measuring the speed of a diffusion pump installed in a vacuum system often gives different results since the geometry, surface area, construction materials, and most importantly, pressure measurement locations differ from the measuring dome.

Backstreaming Measurements

Primary backstreaming can be measured by relatively simple means for pumps without baffles or traps. AVS Standard 4.5 (Journal of Vacuum Science and Technology, Volume 8, Number 5.) recommends the test dome configuration shown in Figure 2. The backstreaming rates published in Varian's catalog are measured using this technique. Any molecules which cross the pump inlet in the upward direction and condense in the dome may be said to be backstreaming. The condensed pumping fluid collects in the trough around the periphery of the dome and drains into a measuring tube. Usually, it takes several days to collect sufficient fluid for satisfactory measurements. Regular volumetric measurements are taken and recorded on a volume versus time graph until the rate is observed to be steady ($\pm 10\%$) for at least 72 hours. The backstreaming rate is the average slope of the Volume-

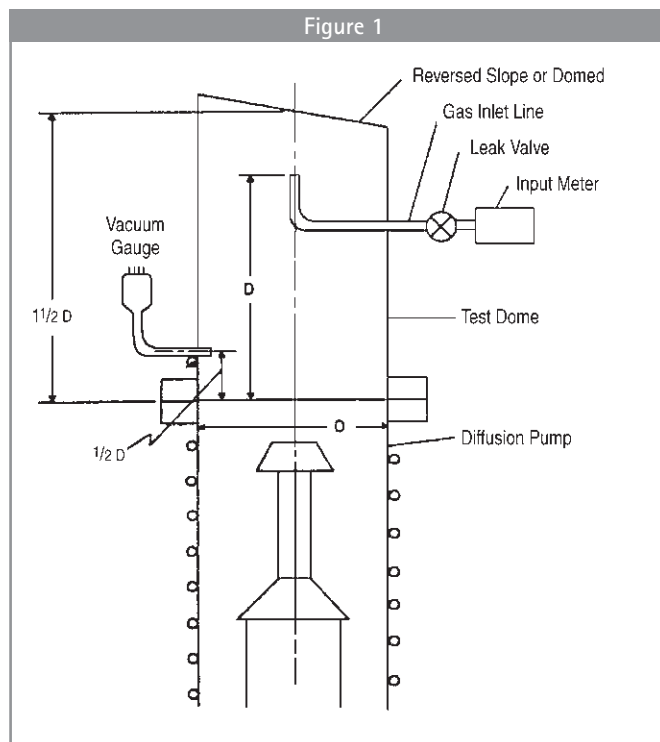

Time curve in the 72 hour time period. Note that this test will ignore "spikes" in the backstreaming rate, which may occur during startup, since only the volume collected during the steady-state, 72-hour period is considered. All backstreaming tests are performed with DC-704 pumping fluid.

The measured backstreaming rate is very dependent on the test method used. If any method other than the dome method described above is used, the results can differ significantly from published values. Note also that the reported backstreaming values are valid for the normal operating range of the pump, at a pressure well below the point at which the top jet starts to break down (i.e. below the "knee" of the speed curve, where the speed is no longer constant with pressure). Above this critical pressure the backstreaming rate may rise markedly.

Backstreaming measurements above the baffle cannot be made with the standard test apparatus. The rates are so low that the collecting surfaces must be refrigerated to prevent re-evaporation, and the collection surface must be designed to collect smaller amounts of fluid.

Using Baffles to Reduce Backstreaming

If the vacuum system has intolerance to backstreaming, a baffle or trap should be considered. Too often a system designer will forego the use of baffles to reduce system cost, only to find the normal amount of backstreaming from the diffusion pumps is too high for the application. This is usually the case for high quality coating applications. The choice of baffle type is a trade-off between backstreaming level, net pumping speed, size, and cost. The designer can choose a water-cooled

halo baffle, water-cooled optically dense baffle, or a cryotrap. A diffusion pump can be ordered with a cold cap or a halo baffle (which has an integral cold cap). If an external baffle is to be used, the diffusion pump is typically ordered with a cold cap.

A water-cooled halo baffle is designed to intercept a majority of the primary backstreaming which escapes the cold cap. A cooled ring, or halo, is strategically placed where most of the backstreaming occurs. The rate is reduced by approximately 90% with a corresponding reduction in speed of roughly 40%. The actual reduction in backstreaming and speed depends on the type of pump and the application conditions. A water-cooled, optically tight baffle is designed to intercept 100% of the primary backstreaming, so what remains is secondary backstreaming. The temperature of the baffle surface, rather than the baffle geometry, determines the secondary backstreaming rate. Thus the choice of baffle becomes a trade-off between size (height), conductance, and cost.

A cryotrap, or liquid nitrogen trap, has a liquid nitrogen reservoir and various baffling surfaces. The reservoir is insulated from the environment by an evacuated space. The LN₂ boils off to atmosphere through a vent port. Since LN₂ boils at -196 °C, the trap's internal surfaces are extremely cold. In systems with liquid nitrogen traps, the backstreaming level can be controlled at such a low level that contaminants from sources other than the diffusion pump will predominate.

Estimating the Effect a Baffle Has on the Speed of the Pump

The degree to which a baffle will reduce the effective pumping speed of a diffusion pump depends on its conductance, which is a function of its geometry. Manufacturers either publish conductance values in L/s or provide an estimate of the retained pumping speed (e.g. "Retains 50% of pumping speed"). When a conductance value for the baffle, C_{baffle} , is published, an estimate of the effective pumping speed, S_{eff} , is given by:

$$S_{\text{eff}} = (C_{\text{baffle}} * S_{\text{pump}}) / (C_{\text{baffle}} + S_{\text{pump}})$$

