

# SCREWLINE

Dry Compressing Screw Vacuum Pump  
for Industrial Applications

# DRYVAC

Dry Compressing Screw Vacuum Pump

# CHEMROVAC

Dry Vacuum Pump  
for Chemical and Pharmaceutical Applications

171.06.02

Excerpt from the Oerlikon Leybold Vacuum Full Line Catalog

Product Section C05

Edition January 2011

# Contents

## Global Versions

### Product SCREWLINE

Applications .....	C05.03
General .....	C05.04

### Products

SCREWLINE SP250 .....	C05.08
SCREWLINE SP630 .....	C05.11

### Accessories

SP-GUARD .....	C05.16
----------------	--------

### Miscellaneous

Vacuum Pump Oils .....	C05.17
Maintenance Kit for changing the Gear Oil .....	C05.17

### Product DRYVAC

Application .....	C05.18
-------------------	--------

### Products

DRYVAC enduro / sprinter/ champion .....	C05.26
--	--------

## Versions for the North and South American Continents

### Product CHEMROVAC AMR

Application .....	C05.28
General .....	C05.28

### Products

CHEMROVAC AMR 70 to 550 .....	C05.30
-------------------------------	--------

# Product SCREWLINE

## Dry Compressing Screw Vacuum Pump

### Application

Dry Compressing Scroll Vacuum Pumps	SCREWLINE SP250	SCREWLINE SP630	SCREWLINE SP630 F	SCREWLINE SP250 ATEX	SCREWLINE SP630 ATEX
<b>Application</b>					
Laser engineering	■	■	■	■	■
Vacuum coating	■	■	■	■	■
Lamination	■	■	■		
Loadlock chambers	■	■	■		
Mechanical engineering	■	■	■	■	■
Automotive industry	■	■	■	■	■
Metallurgy/Furnaces	■	■	■	■	■
Crystal pulling	■	■	■		
Degassing	■	■	■	■	■
Electrical enineering	■	■	■	■	■
Energy technology	■	■	■	■	■
Welding technology	■	■	■		
Lamps/Tubes manufacture	■	■	■	■	■
Cooling and air conditioning	■	■	■	■	■
Chemistry/Pharmaceuticals	■	■	■	■	■
Chemical research laboratories	■	■	■	■	■
Vacuum drying	■	■	■	■	■
Freeze drying systems	■	■	■	■	■
Enviromental engineering	■	■	■	■	■
Packaging	■	■	■	■	■
Medical technology	■	■	■	■	■
Analytical engineering	■	■	■	■	■
Research and development	■	■	■	■	■
Space simulation	■	■	■	■	■
Backing pump for HV-Systems	■	■	■	■	■

# General



Pump system SCREWLINE SP630 with RUVAC WAU 2001

## Principle of Operation

SCREWLINE vacuum pumps are dry compressing backing pumps, the operation of which is based on the screw principle. The pumping chamber of the pump is formed by two synchronised positive displacement rotors and the housing enclosing these. Since the rotors rotate in opposite directions, the chambers move steadily from the intake to the exhaust side of the pumps thereby resulting in a smooth pumping action (see figure below). Since with a single SCREWLINE rotor pair a multi-stage compression process is implemented, the component count in the pumping path is very low. In this way maintenance and servicing work is much simplified.

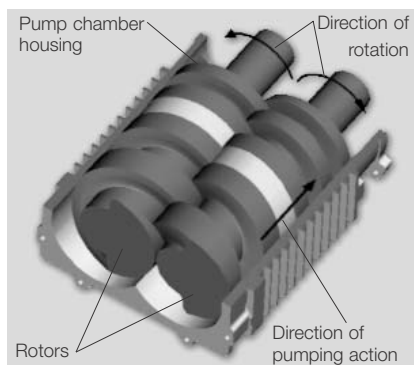

Principle of operation of the SCREWLINE pumps

## Properties

The direct pumping path without multiple deflections for the medium make the SCREWLINE vacuum pumps highly insensitive to foreign materials. This ensures a high uptime in industrial processes.

The two non-contacting shaft-seals are practically wear-free, which allows for very long maintenance intervals.

For standard applications no purge gas is required. However, a purge gas supply can be connected as an option to purge the seals, should the application process require this.

Because of the cantilevered bearing arrangement for the SCREWLINE rotors, a potential source of failure (i.e. a bearing on the intake side) is entirely eliminated. On the one hand, no lubricants from the bearings can enter into the vacuum process, and the other hand also an impairment of the bearing by aggressive process media can be excluded.

A further benefit of the cantilevered bearing arrangement is the easy accessibility of the pump chamber. This innovative design feature allows the removal of the pump housing with

The SCREWLINE pumps were developed in view of the special requirements of industrial applications. The innovative design allows these pumps to be used whenever reliable, compact and low maintenance vacuum solutions are required.

out time-consuming and costly disassembly of the bearings. Thus on-site cleaning of all surfaces in contact with the medium is possible. In particular, if the processes involved considerable amounts of contaminants this is a significant advantage which ensures a long uptime.

Besides the integrated oil cooling arrangement for the rotors, the SCREWLINE pumps are air-cooled from the outside. Here rotor and housings are thermally linked via the oil cooler. Thus, SCREWLINE pumps adapt themselves ideally to the ambient conditions under changing operating situations.



Oil/water cooling unit SP630 F

A water-cooled version is offered as SCREWLINE SP630 F. This product version is intended for operation in air-conditioned rooms.

The SCREWLINE portfolio is completed through ATEX-certified variants.

Moreover, the SCREWLINE portfolio also includes pump versions suited for pumping pure oxygen (O<sub>2</sub>).

## Maintenance and Monitoring

During the development of the SCREWLINE pumps, special emphasis was placed on a particularly simple maintenance concept. This has been implemented through the cantilevered bearing arrangement, with all maintenance components and controls having been located on the so-called service side for easy accessibility. Thus, the space requirement which needs to be taken into account during planning has been optimized. The lower space requirement gives the user more flexibility during installation of the pump.

The monitoring system SP-GUARD was developed especially for constant real-time monitoring of the operational status of the SCREWLINE vacuum pumps.

The operating parameters are constantly acquired and processed. This enables the user to introduce preventive actions early enough so as to ensure trouble-free operation of his SCREWLINE vacuum pumps. The key current operating parameters can be read off from a local display. Moreover, connection to a PLC and remote monitoring is possible. Maintenance of the SCREWLINE pumps will generally be limited to a regular visual inspection of the pump and the annual change of gear oil and oil filter. The oil fill ports as well as the filters are readily accessible and can be easily exchanged.

With the aid of a flushing kit (optional) it is possible to clean the pump chamber, while the pump is operating with-

out process. Deposits due to the process can thus be removed effectively and quickly without the need of having to disassemble the housing.

Also, cleaning of the air/oil heat exchanger can be done simply on-site by blowing out the heat exchanger with compressed air.

## Accessories

SCREWLINE vacuum pumps offer to the user a high degree of flexibility. Inlet and exhaust connections are made through universal flanges, respectively clamped flanges, permit simple integration within the system. Through the accessories which are available, the pump can be optimally adapted to the individual requirements of differing applications.

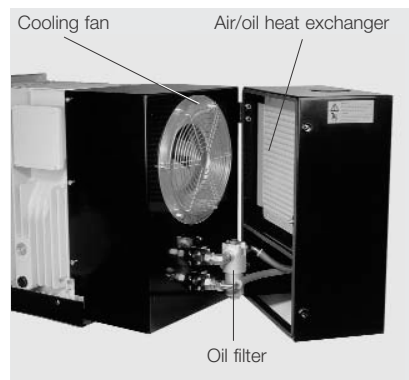

Oil/water cooling unit SP630

## Advantages to the User

- Minimum downtimes, maximum availability, highly rugged
  - The only vacuum pump with a cantilevered bearing arrangement in the industrial market
  - Monitoring through SP-GUARD
  - Highly tolerant of particles and vapours
- Low cost of ownership
  - No purge gas and no cooling water is required for standard applications
  - Low power consumption
  - No contaminated waste oil, no waste disposal costs

- Long maintenance intervals and low servicing complexity
  - Easy and rapid accessibility of all maintenance components and controls
  - Only an annual change of the gear oil is necessary
  - On-site cleaning of the rotors is easy to perform
- Highly flexible
  - Accessories are available for most demanding processes
  - The modular concept allows easy adaptation of the pumping speed of up to 4400 m<sup>3</sup>/h by combination with RUVAC Roots vacuum pumps
  - Connections provided through universal flanges, respectively clamped flanges allow for simple and flexible integration within systems
  - Basic models plus accessories allow the pumps to be equipped according to specific requirements
- High pumping speed at low ultimate pressure

## Typical Applications

- Industrial furnaces
- Coating technology
- Load lock chambers
- Metallurgical systems
- Packaging technology
- Drying processes
- Degassing
- Research and development
- Lamps and tubes manufacture
- Automotive industry
- Packaging industry
- Space simulation
- Electrical engineering
- Energy research

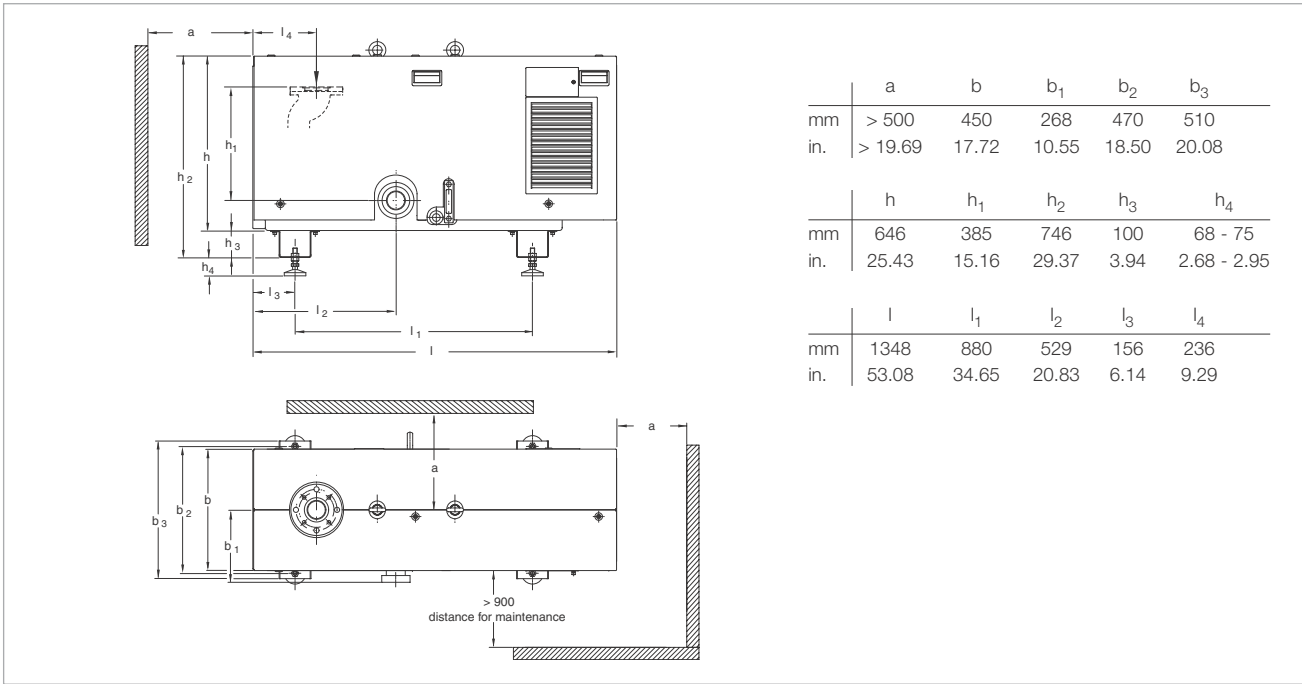

Dimensional drawing for the SCREWLINE SP250

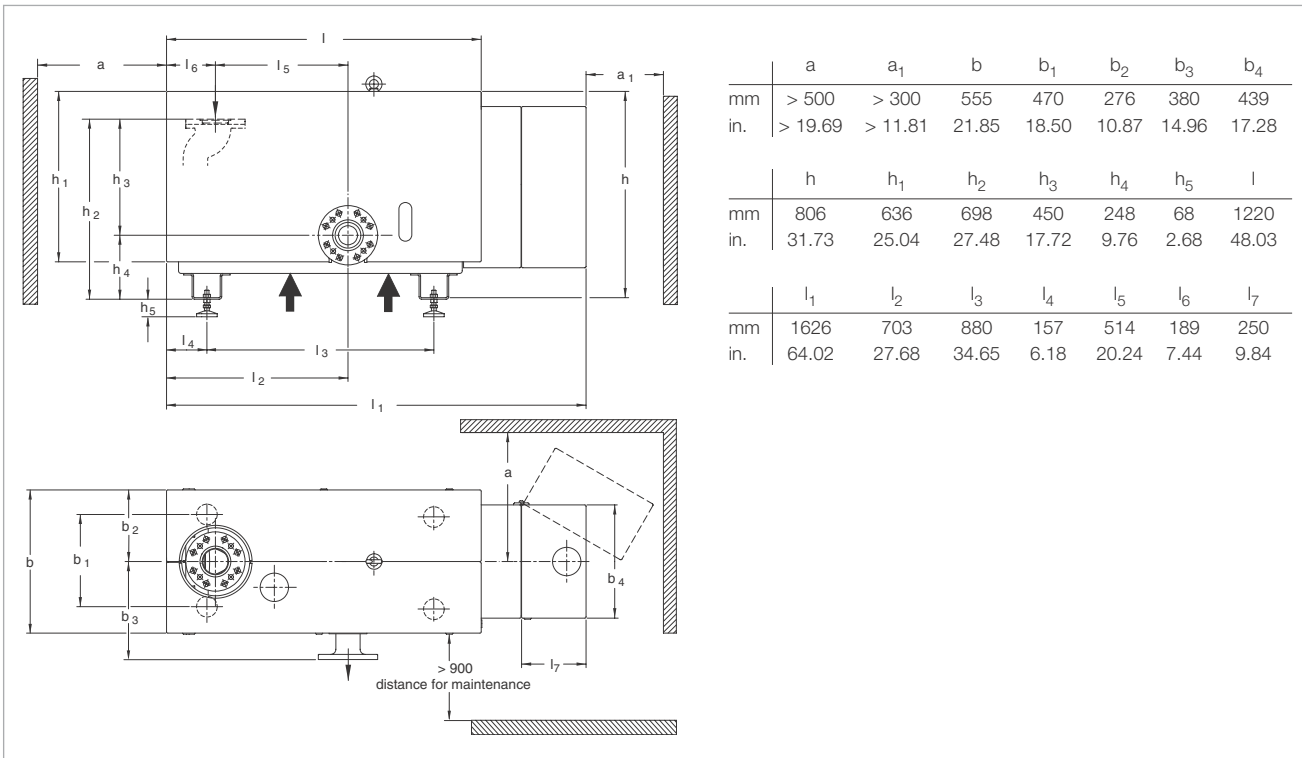

Dimensional drawing for the SCREWLINE SP630

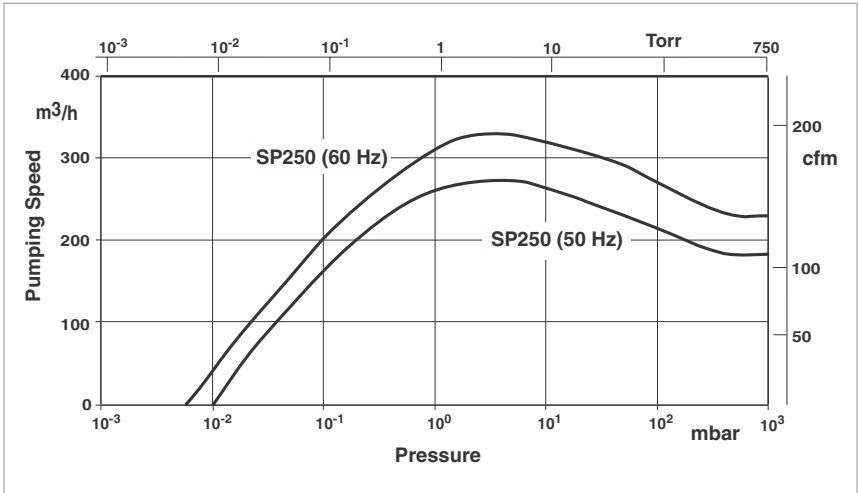

Effective pumping speed of the SCREWLINE SP250 for air, without gas ballast (50/60 Hz)

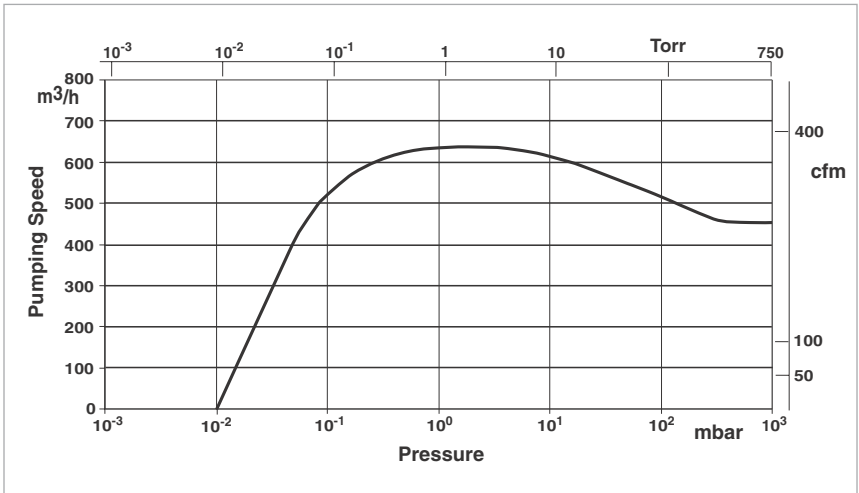

Effective pumping speed of the SCREWLINE SP630 for air, without gas ballast

# Products

## Technical Data

## SCREWLINE SP250

		50 Hz	60 Hz
Effective pumping speed	m <sup>3</sup> x h <sup>-1</sup> (cfm)	270 (≥ 157)	330 (≥ 194)
Ultimate pressure, total	mbar (Torr)	≤ 0.01 (≤ 0.0075)	≤ 0.005 (≤ 0.0038)
Permissible intake pressure, max.	mbar (Torr)	1030 (773)	1030 (773)
Maximum exhaust pressure with reference to the ambient pressure		$p_{ex} = p_{amb} + 200 \text{ mbar (150 Torr)}$ $- 50 \text{ mbar ( 37 Torr)}$	$p_{ex} = p_{amb} + 200 \text{ mbar (150 Torr)}$ $- 50 \text{ mba ( 37 Torr)}$
Permissible ambient temperature	°C (°F)	+10 to +40 (+50 to +104)	+10 to +40 (+50 to +104)
Water vapour tolerance (with gas ballast)	mbar (Torr)	60 (45)	75 (56)
Water vapour capacity (with gas ballast)	kg x h <sup>-1</sup> (gal x h <sup>-1</sup> )	10 (2.7)	18 (4.9)
Installation location		up to 3000 metres (9.800 feet) (above sea level)	up to 3000 metres (9.800 feet) (above sea level)
Cooling		Air	Air
Power supply at operating voltage	ΔΔ Δ	32.0 A / 200 V (cos phi 0.88) 16.0 A / 400 V (cos phi 0.88)	31.5 A / 210 V (cos phi 0.88) 15.5 A / 460 V (cos phi 0.88)
3-ph. nominal current at operating voltage	Δ	14.5 A / 500 V (cos phi 0.88)	–
Nominal power	kW (HP)	7.5 (10.0)	11.5 (15.6)
Power consumption at ultimate pressure	kW (HP) kW (HP)	5.9 (8.0) at 3-ph. 200 V / 400 V 6.5 (8.8) at 3-ph. 500 V	7.2 (9.8) at 3-ph. 200 V / 400 V –
Motor rotational speed	rpm	2920	3505
Type of protection	IP	55	55
Thermal protection class		F	F
Lubricant filling (ANDEROL 555)	l	7	7
Intake flange, standard			
Clamping flange		ISO 1609-1986 (E)-63 (DN 63 ISO-K) <sup>1)</sup>	ISO 1609-1986 (E)-63 (DN 63 ISO-K) <sup>1)</sup>
Bolt flange		ASME B 16.5 NPS 3 class 150	ASME B 16.5 NPS 3 class 150
Bolt flange		EN 1092-2-PN 6 - DN 65	EN 1092-2-PN 6 - DN 65
Exhaust flange, standard			
Clamping flange		ISO 1609-1986 (E)-63 (DN 63 ISO-K)	ISO 1609-1986 (E)-63 (DN 63 ISO-K)
Exhaust flange, optional			
Clamping flange		ISO 1609-1986 (E)-63 (DN 63 ISO-K) <sup>1)</sup>	ISO 1609-1986 (E)-63 (DN 63 ISO-K) <sup>1)</sup>
Bolt flange		ASME B 16.5 NPS 3 class 150	ASME B 16.5 NPS 3 class 150
Bolt flange		EN 1092-2-PN 16 - DN 65	EN 1092-2-PN 16 - DN 65
Bolt flange		EN 1092-2-PN 6 - DN 65	EN 1092-2-PN 6 - DN 65
Materials (components in contact with the gas)		Aluminum, aluminum anodic oxidised, C steel, CrNi steel, grey cast-iron, FPM (FKM) ((Viton))	Aluminum, aluminum anodic oxidised, C steel, CrNi steel, grey cast-iron, FPM (FKM) ((Viton))
Weight, approx.	kg (lbs)	450 (992)	450 (992)
Dimensions (W x D x H)	mm (in.)	1350 x 530 x 880 (53.1 x 20.9 x 34.6)	1350 x 530 x 880 (53.1 x 20.9 x 34.6)
Noise level <sup>2)</sup>	dB(A)	67	72

<sup>1)</sup> This flange is required when ISO-K flanges are to be connected (Part No. 267 47)

<sup>2)</sup> With connected exhaust gas line at ultimate pressure (in acc. with ISO 4871)

## Ordering Information

	Standard	SCREWLINE SP250 ATEX	O <sub>2</sub>
	Part No.	Part No.	Part No.
SCREWLINE SP250 (50/60 Hz) with SP-GUARD and manual gas ballast	<b>115 001</b>	-	-
with SP-GUARD and electromagnetic gas ballast	<b>115 002</b>	-	-
with manual gas ballast	<b>115 004</b>	-	-
with electromagnetic gas ballast	<b>115 005</b>	-	-
with SP-GUARD, purge gas unit, castors and manual gas ballast valve	<b>115 006</b>	-	-
with SP-GUARD, electromagnetic gas ballast and purge gas unit Category 3GD IIC 160 °C inside	-	<b>115 003<sup>1)</sup></b>	-
with SP-GUARD, special gaskets, electromagnetic gas ballast and purge gas unit Category 3GD IIC 160 °C inside	-	<b>115 009</b>	-
with SP-GUARD, electromagnetic gas ballast and purge gas unit Category 3GD IIC 160 °C inside / Category 3GD Ex nA IIC 160 °C outside	-	<b>115 010</b>	-
with SP-GUARD, electromagnetic gas ballast and purge gas unit Category 2G3D b IIC 135 °C inside / Category 3GD Ex nA IIC 160 °C outside (50 Hz only)	-	<b>115 011</b>	-
with SP-GUARD, electromagnetic gas ballast Purge vent vit, FFPM gaskets and purge gas unit Category 2G3D b IIC 135 °C inside / Category 3GD Ex nA IIC 160 °C outside (50 Hz only)	-	<b>115 012V</b>	-
Category 2Gb IIC T4 3D T 130 °C X inside / Category 2Gb IIC T4 3D T 130 °C X outside electropneumatic gas ballast, sensors, wired including junction box, purge gas unit (3-ph. only, 500 V, 50 Hz; DN 65 PN 16) 2)	-	-	<b>115 019</b>

<sup>1)</sup> ATEX Category 3 as standard (Directive 94/9/EG)

<sup>2)</sup> T4 with max.  $p_{ex} = p_{amb} + 200 \text{ mbar}$   
 $+ 050 \text{ mbar}$

For all enquiries and orders relating to category 1 and 2 ATEX products please exclusively use our ATEX questionnaire. You can find this questionnaire at the end of the full-line catalog together with the fax forms or in the Internet under "[www.oerlikon.com/leyboldvacuum](http://www.oerlikon.com/leyboldvacuum)" under Download Documents in the area Documentation.

## Ordering Information

## SCREWLINE SP250

### Accessories

	Standard	ATEX	O <sub>2</sub>
	Part No.	Part No.	Part No.
Exhaust silencer	119 002	119 002	119 002
Serviceable silencer	119 003V	119 003V	119 003V
Exhaust non-return valve (DN 65 PN 6)	119 011	-	-
Adaptor for RUVAC 501/1001	119 022	119 022	119 022
Purge gas retrofit kit	119 031	-	-
Inlet filter adapter DN 63 ISO-K	119 019	119 019	-
Dust filter	951 68	-	-
Purge vent vit	119 061V	119 061V	119 061V
Flushing kit, category 2G Ex em II T5 / air inlet kit <sup>1)</sup>	119 015 and 119016	119 015 and 119016	-
Transportation drawbar (upon request)	119 017	-	-
Maintenance kit, level 1	EK 110 000 820	EK 110 000 820 <sup>2)</sup>	EK 110 000 820
Maintenance kit, level 2	EK 110 000 821	EK 110 000 821 <sup>2)</sup>	EK 110 000 821
Purge gas connection servicing kit	EK 110 000 834	EK 110 000 834 <sup>2)</sup>	-
Filter for gas ballast	E 110 000 980	E 110 000 980 <sup>2)</sup>	E 110 000 980
Filter for purge gas valve unit	E 110 000 850	E 110 000 850	E 110 000 850
Absorbing felt	E 110 002 435	E 110 002 435	E 110 002 435

<sup>1)</sup> Flushing kit / air inlet kit used together

<sup>2)</sup> Spare Parts can only be used for Part No.115 003, 115 010 and 115 011

## SCREWLINE SP630

### Technical Data

		50 Hz	60 Hz
Pumping speed	$\text{m}^3 \times \text{h}^{-1}$ (cfm)	630 (371)	630 (371)
Ultimate total pressure	mbar (Torr)	$\leq 0.01$ ( $\leq 0.0075$ )	$\leq 0.01$ ( $\leq 0.0075$ )
Maximum exhaust pressure with reference to the ambient pressure		$P_{\text{ex}} = P_{\text{amb}} + 200 \text{ mbar (150 Torr)}$ $- 50 \text{ mbar ( 37 Torr)}$	$P_{\text{ex}} = P_{\text{amb}} + 200 \text{ mbar (150 Torr)}$ $- 50 \text{ mbar ( 37 Torr)}$
Intake pressure limits, max.	mbar (Torr)	1030 (773)	1030 (773)
Permissible ambient temperature	$^{\circ}\text{C}$ ( $^{\circ}\text{F}$ )	+10 to +40 (+50 to +104)	+10 to +40 (+50 to +104)
Water vapour tolerance (with gas ballast)	mbar (Torr)	40 (30)	40 (30)
Water vapour capacity (with gas ballast)	$\text{kg} \times \text{h}^{-1}$ (gal $\times \text{h}^{-1}$ )	14 (3.7)	14 (3.7)
Installation location		up to 3000 metres (9.800 feet) (above sea level)	up to 3000 metres (9.800 feet) (above sea level)
Cooling		Air	Air
Power supply	$\Delta\Delta$ $\Delta$	56 A / 200 V 28 A / 400 V	52 A / 210 V 24 A / 460 V
cos $\phi$		0.89	0.90
Nominal power	kW (HP)	15 (20)	15 (20)
Power consumption at ultimate pressure	kW (HP)	$< 11$ ( $< 15$ )	$< 11$ ( $< 15$ )
Motor rotational speed	rpm	2930	3530
Type of protection	IP	55	55
Thermal protection class		F	F
Lubricant filling (ANDEROL 555)	l	15	15
Intake flange and exhaust flange compatible with bolt flanges		EN 1092-2 - PN 6 - DN 100 EN 1092-2 - PN 16 - DN 100 ISO 1609-1986 (E)-100 (DN 100 ISO-K) <sup>1)</sup> ASME B 16.5 NPS4 class 150	EN 1092-2 - PN 6 - DN 100 EN 1092-2 - PN 16 - DN 100 ISO 1609-1986 (E)-100 (DN 100 ISO-K) <sup>1)</sup> ASME B 16.5 NPS4 class 150
Materials (components in contact with the gas)		Aluminum, aluminium anodic oxidised, C steel, CrNi steel, grey cast-iron, FPM (FKM) (Viton))	Aluminum, aluminium anodic oxidised, C steel, CrNi steel, grey cast-iron, FPM (FKM) (Viton))
Weight, approx.	kg (lbs)	530 (1166)	530 (1166)
Dimensions (W x D x H)	mm (in.)	1630 x 660 x 880 (64 x 26 x 35)	1630 x 660 x 880 (64 x 26 x 35)
Noise level <sup>2)</sup>	dB(A)	73	75

<sup>1)</sup> This flange is required when ISO-K flanges are to be connected (P/N 267 50)

<sup>2)</sup> With connected exhaust gas line at ultimate pressure (in acc. with ISO 4871)

## SCREWLINE SP630 F

### Additional Technical Data

		50 Hz	60 Hz
Cooling		Water	Water
Water connection	G	1/2" ISO 228-1	1/2" ISO 228-1
Water temperature	$^{\circ}\text{C}$ ( $^{\circ}\text{F}$ )	+5 to +35 (+41 to +95)	+5 to +35 (+41 to +95)
Minimum water feed pressure	bar (psi, gauge)	2 (15)	2 (15)
Nominal flow at a water feed temperature of 25° C (77 °F)	l/min (gal/min)	12 (3)	12 (3)
Noise level <sup>1)</sup>	dB(A)	71	71

<sup>1)</sup> With connected exhaust gas line at ultimate pressure (in acc. with ISO 4871)

## Ordering Information

## SCREWLINE SP630/SP630 F

	<b>50 Hz</b>	<b>60 Hz</b>
	<b>Part No.</b>	<b>Part No.</b>
SCREWLINE SP630		
air cooled,		
with adapter for RUVAC 2001, SP-GUARD and electromagnetic gas ballast	<b>117 005</b>	<b>117 006</b>
with SP-GUARD and manual gas ballast	<b>117 007</b>	<b>117 008</b>
with SP-GUARD and electromagnetic gas ballast	<b>117 009</b>	<b>117 010</b>
with adaptor for RUVAC 2001, SP-GUARD and manual gas ballast	<b>117 011</b>	<b>117 012</b>
with electromagnetic gas ballast	<b>117 021</b>	<b>117 022</b>
with manual gas ballast	<b>117 023</b>	<b>117 024</b>
SCREWLINE SP630 F		
water cooled,		
with adapter for RUVAC 2001, SP-GUARD and electromagnetic gas ballast	<b>117 105</b>	<b>117 106</b>
with adapter for RUVAC 2001, SP-GUARD and manual gas ballast		
50 Hz	<b>117 109</b>	-
with SP-GUARD and manual gas ballast	<b>117 107</b>	<b>117 108</b>
with SP-GUARD, purge gas kit and manual gas ballast	<b>117 113</b>	<b>117 114</b>
SCREWLINE SP630 S1		
water cooled,		
with adapter for RUVAC 2001, castors, SP-GUARD, purge gas kit and electromagnetic gas ballast	<b>117 117</b>	<b>117 118</b>
SCREWLINE SP630 FK		
water cooled,		
with adapter for RUVAC 1001, castors, SP-GUARD, purge gas kit and electromagnetic gas ballast	<b>117 125</b>	-

## Ordering Information

## SCREWLINE SP630 / SP630 F Standard

### Accessories

### 50 Hz

### 60 Hz

	Part No.	Part No.
Exhaust silencer	119 001	119 001
Serviceable silencer	119 004V	119 004V
Silencer kit	119 005V0	119 005V0
Water connection accessories for Part No. 119 005V0	119 006V0	119 006V0
Roots pump adapter for RUVAC 1001 <sup>1)</sup>	500 003 173	500 003 173
for RUVAC 2001	119 021	119 021
für RUVAC WH 2500	115 222V	115 222V
für RUVAC WH 4400	119 024V	119 024V
Dust filter <sup>2)</sup>	951 72	951 72
Elbow 90° (DN 100 ISO-K)	887 26	887 26
Clamping screws for DN 63-250 ISO-K	267 01	267 01
Centering ring for DN 100 ISO-K	268 06	268 06
Purge vent Kit	119 060V	119 0600V
Inlet filter adapter DN 100 ISO-K	119 020	119 020
Gas ballast, manual	119 051	119 051
Gas ballast, 24 V DC (DN 16 KF) <sup>3)</sup>	119 052	119 052
SP-GUARD kit, complete <sup>4)</sup>	EK 110 000 809	EK 110 000 809
Non-return valve (DN 100 PN 6)	119 010	119 010
Purge gas retrofit kit <sup>3)</sup>	119 030	119 030
Flushing kit, category 2G Ex em II T5 / air inlet kit <sup>5)</sup>	119 015 and 119 016	119 015 and 119 016
Transportation drawbar for Part No. 117 117 / 117 118	119 017	Part No. 119 017
Maintenance kit, level 1 up to serial number 31000197911	EK 110 000 792	EK 110 000 792
from serial number 31000197911	EK 110 000 832	EK 110 000 832
Maintenance kit, level 2	EK 110 000 793	EK 110 000 793
Purge gas connection servicing kit	EK 110 000 827	EK 110 000 827
Filter for gas ballast	E 110 000 980	E 110 000 980
Filter for purge gas valve unit	E 110 000 850	E 110 000 850
Water filter maintenance kit for SP630 F	EK 110 000 813	EK 110 000 813

<sup>1)</sup> Must mount to adapter Part No. 119 021

<sup>2)</sup> For information on the dust filter please refer to the Product Section C02, Section "Accessories"

<sup>3)</sup> Not for ATEX pumps

<sup>4)</sup> Can only be installed as a service provided by Oerlikon Leybold Vacuum

<sup>5)</sup> Flushing kit / air inlet kit used together

## Ordering Information

## SCREWLINE SP630 / SP630 F ATEX

	<b>50 Hz</b>	<b>60 Hz</b>
	<b>Part No.</b>	<b>Part No.</b>
SCREWLINE SP630 with SP-GUARD, purge gas kit and manual gas ballast Category 3G IIC (160 °C) inside	<b>117 017</b>	<b>117 018</b>
with SP-GUARD, purge gas kit and electromagnetic gas ballast Category 3G IIC (160 °C) inside	<b>117 019</b>	<b>117 020</b>
SCREWLINE SP630 F, water cooled Category 2G3D IIC (160 °C) Category 3G IIC T3 (160 °C) with purge gas monitor, SP-GUARD, adapter for RUVAC 2001 and electromagnetic gas ballast	<b>117 111</b>	<b>117 112</b>
Category 3G IIC 160 °C inside SP-GUARD, purge gas kit and electromagnetic gas ballast	<b>117 115</b>	<b>117 116</b>
Exhaust silencer	<b>119 001</b>	<b>119 001</b>
Roots pump adapter for RUVAC 1001 <sup>1)</sup> for RUVAC 2001	<b>500 003 173</b> <b>119 021</b>	<b>500 003 173</b> <b>119 021</b>
Inlet filter adapter DN 100 ISO-K	<b>119 020</b>	<b>119 020</b>
Non-return valve (DN 100 PN 6)	<b>119 010</b>	<b>119 010</b>
Flushing kit, category 2G Ex em II T5 / air inlet kit <sup>2)</sup>	<b>119 015</b> <b>and 119 016</b>	<b>119 015</b> <b>and 119 016</b>
Maintenance kit, level 1 up to serial number 31000197911 from serial number 31000197911	<b>EK 110 000 792</b> <b>EK 110 000 832</b>	<b>EK 110 000 792</b> <b>EK 110 000 832</b>
Maintenance kit, level 2	<b>EK 110 000 793</b>	<b>EK 110 000 793</b>
Purge gas connection servicing kit	<b>EK 110 000 827</b>	<b>EK 110 000 827</b>
Filter for gas ballast	<b>E 110 000 980</b>	<b>E 110 000 980</b>
Water filter maintenance kit for SP630 F	<b>EK 110 000 813</b>	<b>EK 110 000 813</b>

## Ordering Information

## SCREWLINE SP630 O<sub>2</sub>

	<b>50 Hz</b>	<b>60 Hz</b>
	<b>Part No.</b>	<b>Part No.</b>
SCREWLINE SP630 with SP-GUARD, purge gas monitor and electromagnetic gas ballast	<b>117 039</b>	<b>117 040</b>
Exhaust silencer	<b>119 001</b>	<b>119 001</b>
Roots pump adapter for RUVAC 1001 <sup>1)</sup> for RUVAC 2001	<b>500 003 173</b> <b>119 021</b>	<b>500 003 173</b> <b>119 021</b>
Maintenance kit, level 1 up to serial number 31000197911 from serial number 31000197911	<b>EK 110 000 792</b> <b>EK 110 000 832</b>	<b>EK 110 000 792</b> <b>EK 110 000 832</b>
Maintenance kit, level 2	<b>EK 110 000 793</b>	<b>EK 110 000 793</b>
Purge gas connection servicing kit	<b>EK 110 000 827</b>	<b>EK 110 000 827</b>
Filter for gas ballast	<b>E 110 000 980</b>	<b>E 110 000 980</b>
Filter for purge gas valve unit	<b>E 110 000 850</b>	<b>E 110 000 850</b>

<sup>1)</sup> Must mount to adapter Part No. 119 021

<sup>2)</sup> Flushing kit / air inlet kit used together

For all enquiries and orders relating to category 1 and 2 ATEX products please exclusively use our ATEX questionnaire. You can find this questionnaire at the end of the full-line catalog together with the fax forms or in the Internet under "[www.oerlikon.com/leyboldvacuum](http://www.oerlikon.com/leyboldvacuum)" under Download Documents in the area Documentation.

# Accessories

## SP-GUARD



The monitoring system SP-GUARD was specially developed for constantly monitoring the operational status of the screw vacuum pump SCREWLINE SP630 in real-time.

The operational parameters are constantly collected and evaluated.

In this way a high degree of reliability is attained.

### Technical Data

### SP-GUARD

Power supply through power supply unit	V DC	24
Current consumption	A	0.2

### Ordering Information

### SP-GUARD

	Part No.
SP-GUARD kit, complete <sup>1)</sup>	<b>EK 110 000 809</b>
Supply 24 V DC, 230/120 V AC, 50/60Hz for SP-GUARD	<b>152 50</b>

<sup>1)</sup> Can only be installed as a service provided by Oerlikon Leybold Vacuum

# Miscellaneous

## Vacuum Pump Oils

Lubricating oils for vacuum pumps must meet tough requirements. They need to have excellent lubricating properties and resistant against thermal decomposition and increased mechanical stress.

The vacuum pump oil Anderol 555 detailed below was qualified for usage in the SCREWLINE line of pumps through a comprehensive series of experiments under application conditions in our own factory laboratories.

Our oils are subjected to an involved qualification process with respect to their technical suitability in our vacuum pumps.

Our warranty commitment is dependent on the usage of lubricating oils which are qualified by us.

No liability will be assumed for any damage caused by the use of types of oil which have not been qualified or which are unsuitable.

Safety data sheets are available to professional users from:

E.mail "documentation.vacuum@oerlikon.com" or Internet "www.oerlikon.com/leyboldvacuum".

### Application Data

### ANDEROL 555

Type of oil	Diester oil
-------------	-------------

### Ordering Information

### Maintenance Kit for changing the Gear Oil

	Part No. EK
Maintenance kit stage 1 SP250 for changing the gear oil ANDEROL 555, oil filter cartridge and gaskets	<b>EK 110 000 820</b>
SP630 for changing the gear oil up to serial number 31000197911 ANDEROL 555, oil filter cartridge BG30 and 2 gaskets	<b>EK 110 000 792</b>
from serial number 31000197911 ANDEROL 555, oil filter cartridge BG60 and 2 gaskets	<b>EK 110 000 832</b>
Maintenance kit level 2 SP630 for pump chamber inspection, 2 O-rings, inlet screen including O-rings	<b>EK 110 000 793</b>
Maintenance kit level 3 SP630 for axial bearing replacement, 2 O-rings, 6 gaskets (Cu), 2 angular contact ball bearings	<b>EK 110 000 794</b>
Oil ANDEROL 555 1 liter (1.1 qt) 5 liters (5.3 qt) 20 liters (21.1 qt)	<b>EK 200 10 272</b> <b>EK 200 10 891</b> <b>EK 200 00 193</b>

# Product DRYVAC

## Dry Compressing Screw Vacuum Pump

### Application

Pumps	DRYVAC enduro 650 S	DRYVAC enduro 650 S-r	DRYVAC sprinter 650 S	DRYVAC sprinter 650 S-i	DRYVAC champion 650 S	DRYVAC champion 650 S-r	DRYVAC champion 650 S-i	DRYVAC champion 5000 RS-i
<b>Applications</b>								
Packaging	■	■						
Automotive industry	■	■						
Vacuum drying	■	■	■	■				
Electrical components	■	■						
Energy technology	■	■			■	■	■	■
Degassing	■	■						
Lamination	■	■			■	■	■	■
Industrial gases	■	■			■	■		
Wind turbines	■	■						
Leak testing machines	■	■	■	■				
Load lock chambers			■	■				
Metallurgy/Furnaces	■	■						
Crystal growing	■	■			■	■	■	■
Welding technology	■	■	■	■				
Refrigeration and air conditioning	■	■						
Plasma cleaning or activation	■	■			■	■	■	■
Sterilization					■	■	■	■
Freeze drying	■	■			■	■	■	■
Vacuum coating					■	■	■	■
Research and development	■	■			■	■	■	■
Space simulation	■	■						
Backing pump for Highvacuum systems	■	■						

# DRYVAC enduro / sprinter/ champion 650 S, 650 S-r, 650 S-i and 5000 RS-i



DRYVAC series

DRYVAC is a new family of dry compressing screw vacuum pumps available with different features depending on the specific application. The DRYVAC family was developed in consideration of the special requirements of the photovoltaic, display and process industries. All DRYVAC variants are water cooled, very compact and easy to combine into systems, in particular with the well-proven Roots pumps of the RUVAC WH, WS and WA series.

## The Benefits of the Screw Principle

The direct pumping path without multiple deflections of the gas makes the DRYVAC vacuum pumps very insensitive to foreign materials. This ensures a high reliability in industrial processes. The straight and short path for the gas from the inlet of the pump to its exhaust reduces the dwell time of the gas and thereby reduces potential deposits within the pump. Through the use of a purge gas (e.g. gas ballast), any deposits, particles and condensates can be effectively removed.

Just like the SCREWLINE, the DRYVAC was developed for demanding applications. However, the range of applications is extended by the DRYVAC to include numerous photovoltaic and display production processes. A unique characteristic of the SCREWLINE series is the availability of air cooling and the low internal surface temperatures allowing applications like lamination, for example, to be run with long uptimes and low maintenance complexity.

## The Best DRYVAC for every Application

The **DRYVAC enduro** and **sprinter** versions deliver their optimum pumping speed also at pressures exceeding 100 mbar. These types are suited for short cycle operation (load locks, for example) or for the evacuation of large vacuum chambers.

The **DRYVAC enduro** pumps are equipped with all features necessary for process industry applications (gas ballast, for example).

The **DRYVAC champion** models offer reliability in connection with harsh processes. They have been optimised for pumping media typically employed in photovoltaic and flat screen production processes. The DRYVAC champion offers a high pumping speed for hydrogen and owing to its integrated purge gas system is insensitive to dust.

Main features and customer benefits offered by the DRYVAC are the compact design, the low-profile and the option of being able to easily build horizontally arranged pump systems and the power consumption reduced by up to 30% compared to screw pumps of the 630 m<sup>3</sup>/h pumping speed class.

These DRYVAC variants are available in different configuration levels: in the case of the **DRYVAC S** the frequency converter has been integrated within the pump, whereas in the case of the **DRYVAC S-r** it is to be integrated in an external electrical cabinet. The **DRYVAC S-i** versions expand the DRYVAC S by a PLC with a touch screen display and a software user interface allowing easy operation and configuration. The S-i versions are linked to the system as standard through a Profibus or a 24 V I/O interface (other interfaces upon request). Additionally, the S-i versions are accommodated in a full enclosure with castors, height adjustable feet and Harting socket/plug.

The **DRYVAC champion 5000 RS-i** is a special variant of the DRYVAC S-i. This process pump is an autonomously controlled combination consisting of a DRYVAC champion 650 S screw pump and a new member of the RUVAC WH series, the WH 2500. Just like the screw pump, the RUVAC is also operated and controlled by a frequency converter (100 Hz max.) The effective pumping speed of the combination amounts to approximately 3800 m<sup>3</sup>/h for nitrogen.

## Design Features of the DRYVAC Family

- Water cooled
- Hermetically sealed screw and Roots pumps, static seals only towards the outside
- Simple mechanical and electrical integration
- Integrated protection function via temperature, exhaust pressure and current consumption
- Small footprint
- Low energy consumption due to optimised rotor geometry and innovative motor design meeting IE2 efficiency class requirements
- Wide voltage and frequency range: 380-480 V, 50/60 Hz
- UL listed materials (NRTL certification pending)
- RoHS compliant

### Typical Applications

- Solar coating (SiN, ZnO, a-Si/ $\mu$ -Si, CdTe, CIS/CIGS, etc.)
- Load lock
- Polysilicon production
- Display and glass coating
- Wear protection coating
- Strip coating
- Furnaces
- Metallurgy
- Vacuum drying
- Electron beam welding

### The Benefits at a Glance

Most compact dry pump, with the smallest footprint for pump systems

- Optimized Cost of Ownership including the lowest power consumption available on the market today
- Utmost package flexibility
- Low noise level
- Highest reliability
- Integrated self-monitoring and control
- No unscheduled down times, minor maintenance demands

### The DRYVAC series

comprises the models

DRYVAC 650 S

DRYVAC 650 S-i

DRYVAC 650 S-r

DRYVAC 5000 RS-i

and allows for numerous combinations with Roots pumps from the RUVAC series.

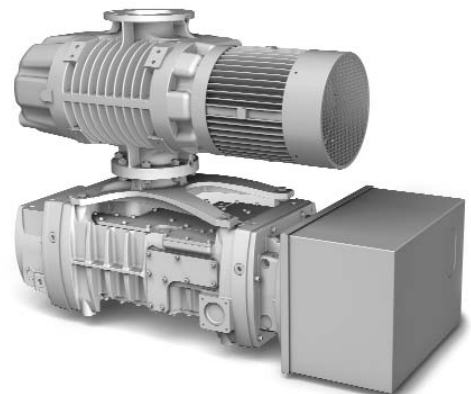
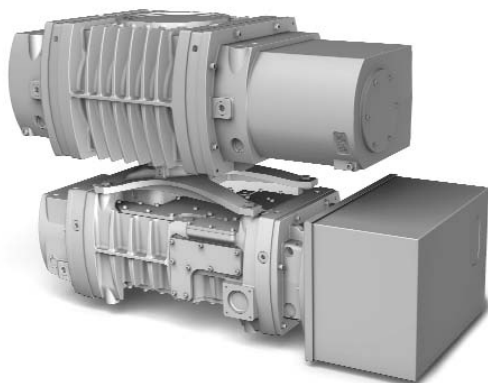
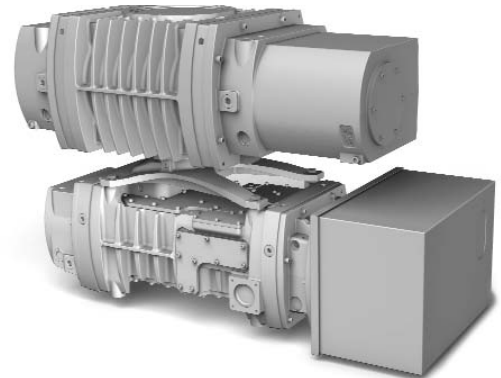
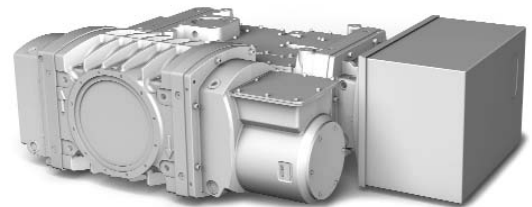
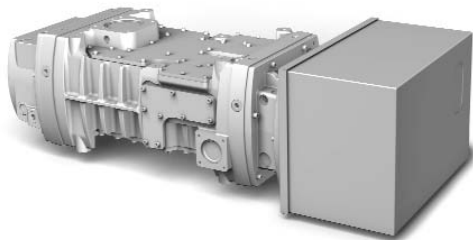

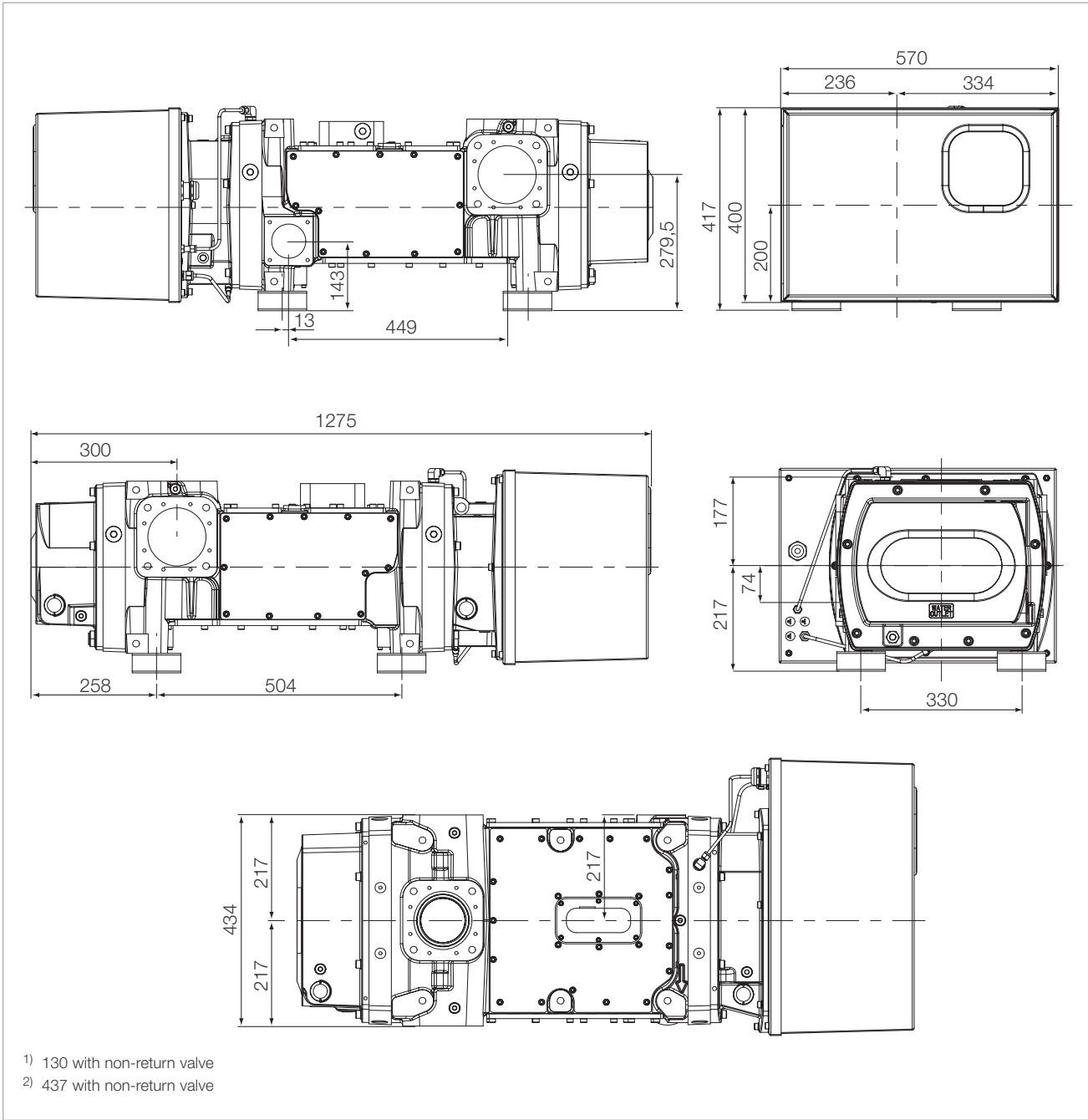

Dimensional drawing for the DRYVAC 650 S

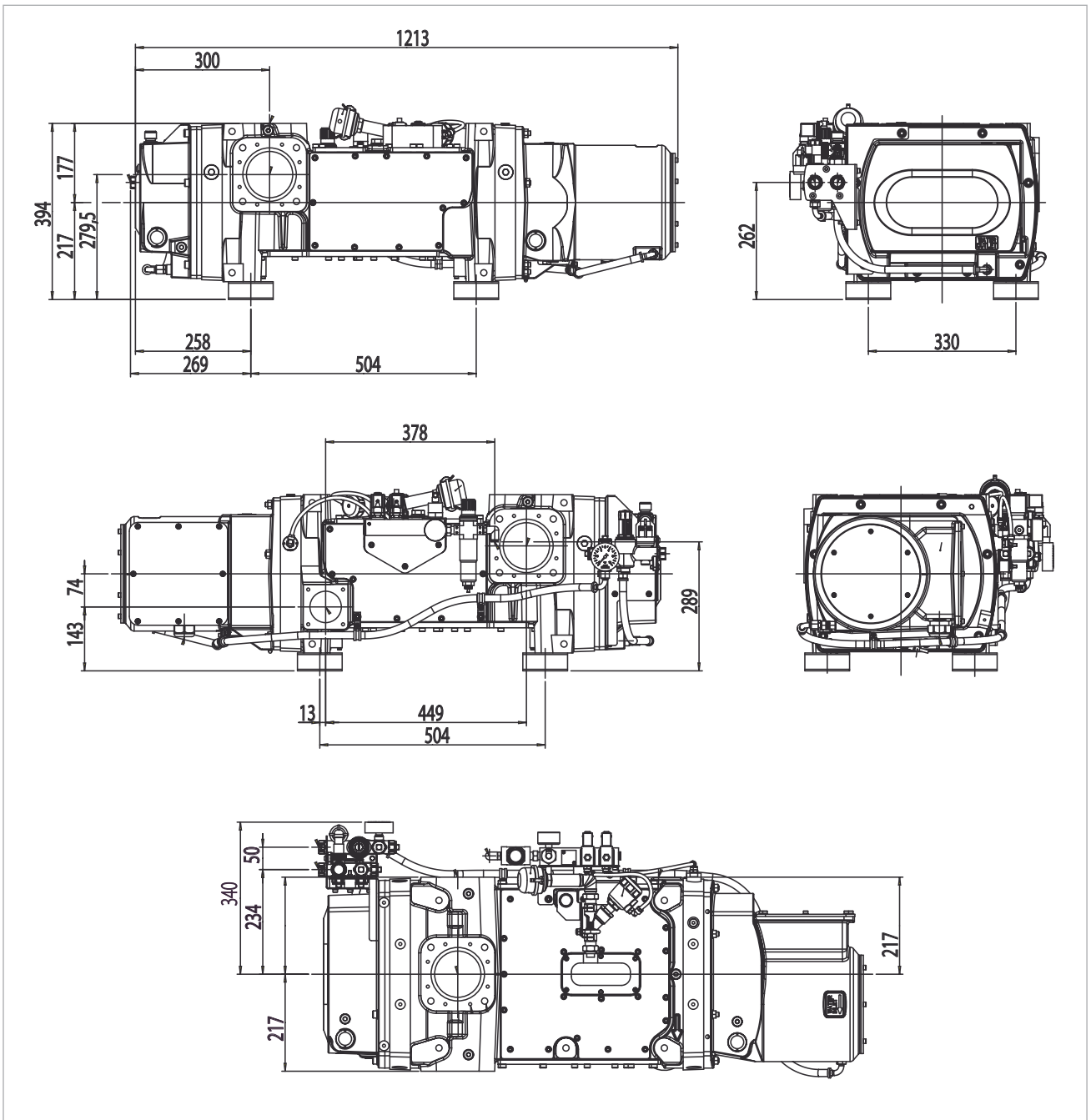

Dimensional drawing for the DRYVAC 650 S-r

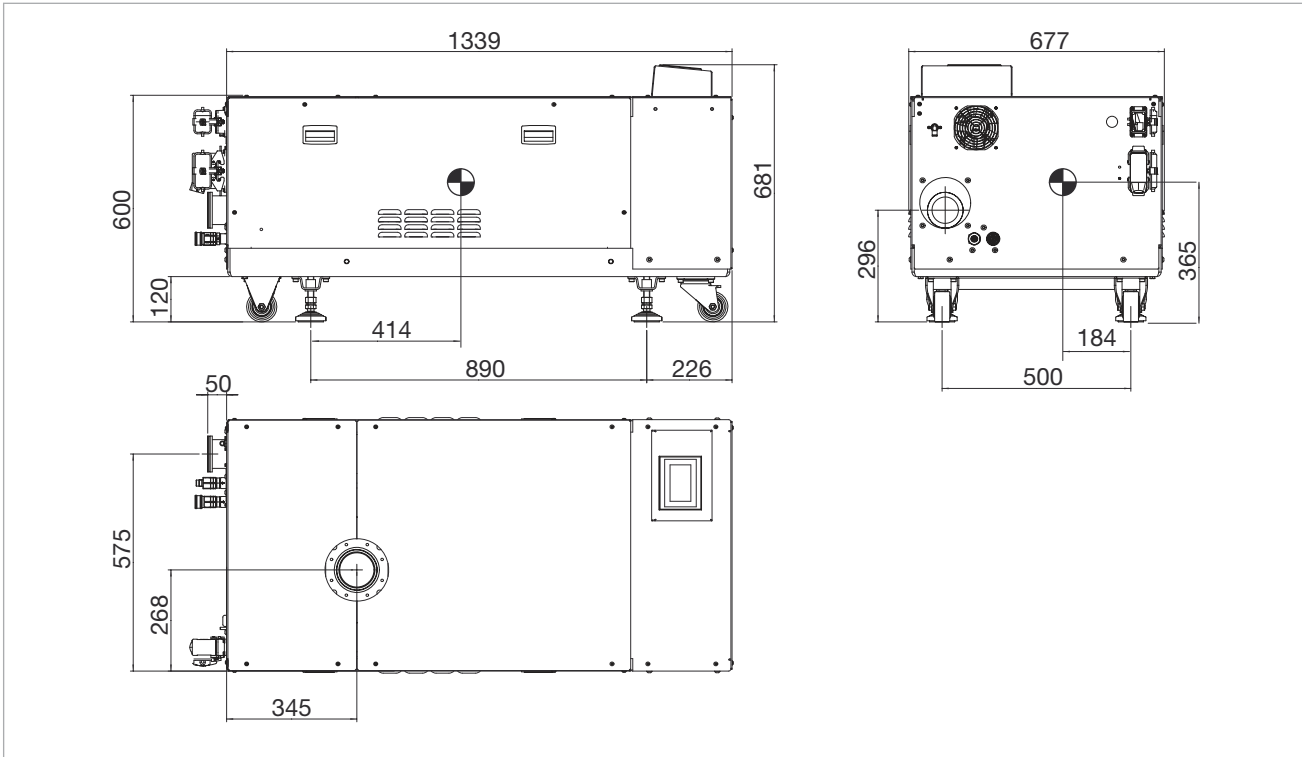

Dimensional drawing for the DRYVAC 650 S-i

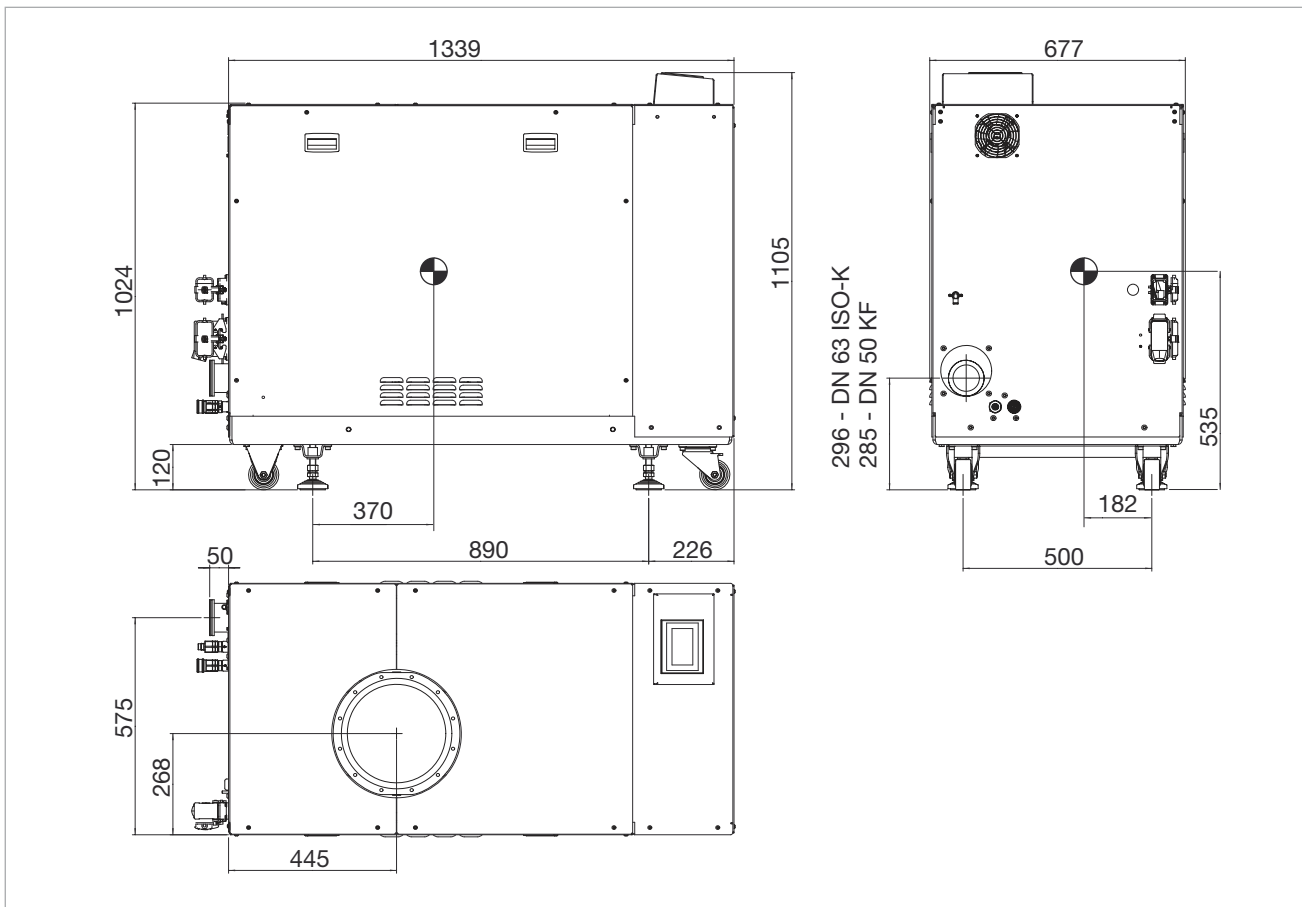

Dimensional drawing for the DRYVAC 5000 RS-i

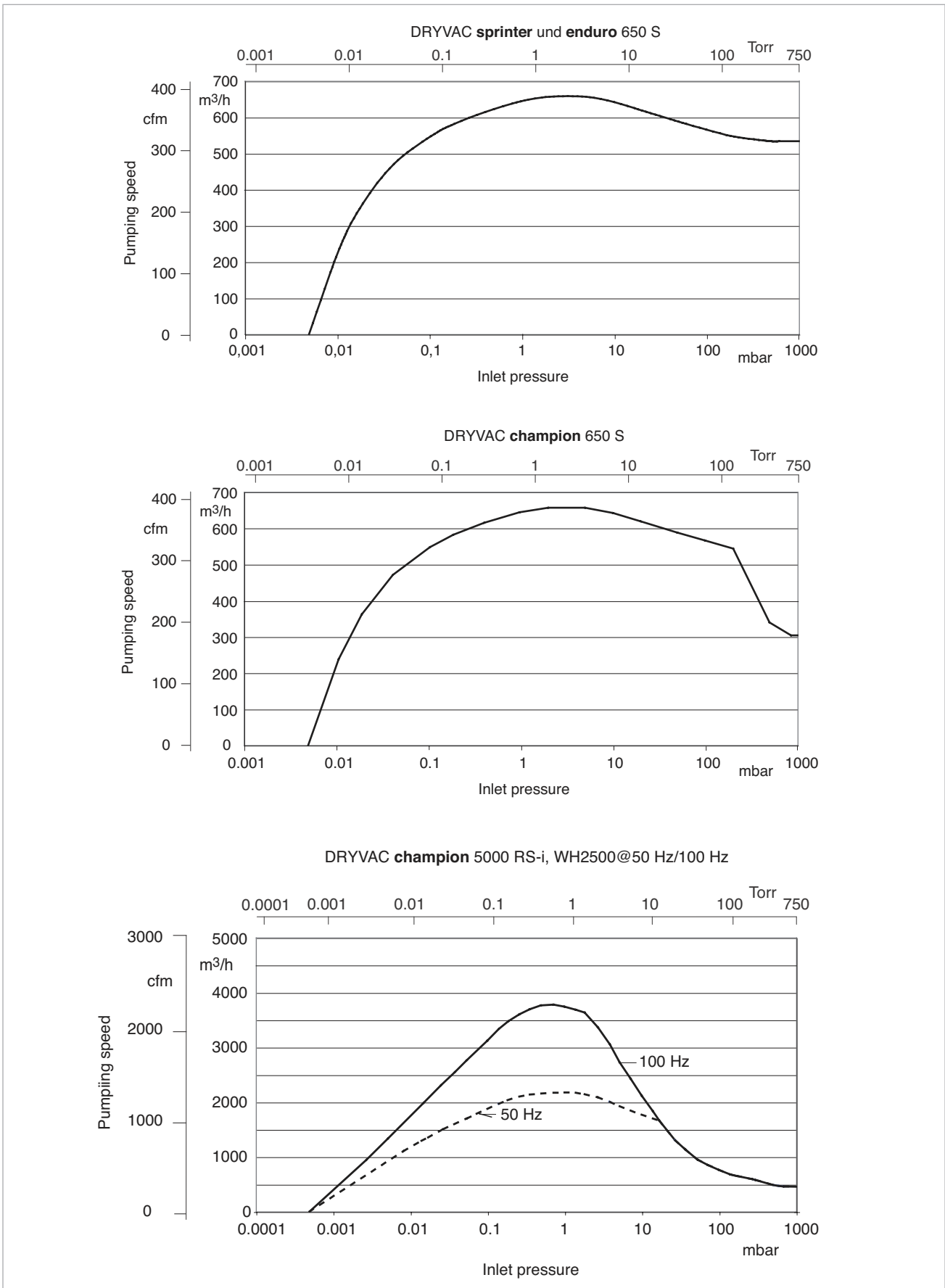

Pumping speed curves of the DRYVAC **sprinter**, resp. **enduro 650 S**, DRYVAC **champion 650 S** pumps and the DRYVAC **champion 5000**

## Technical Data

## DRYVAC enduro / sprinter / champion

		5000 RS-i	650 S-i	650 S	650 S-r
Nominal pumping speed	m <sup>3</sup> /h (cfm)	5000 (2945)	650 (383)	650 (383)	650 (383)
Max. effective pumping speed	m <sup>3</sup> /h (cfm)	3800 (2238)	650 (383)	650 (383)	650 (383)
Ultimate pressure	mbar (Torr)	5 x 10 <sup>-4</sup> (4 x 10 <sup>-4</sup> )	5 x 10 <sup>-3</sup> (4 x 10 <sup>-3</sup> )	5 x 10 <sup>-3</sup> (4 x 10 <sup>-3</sup> )	5 x 10 <sup>-3</sup> (4 x 10 <sup>-3</sup> )
Permissible ambient temperature	°C (°F)	+5 to +40 (+41 to +104)	+5 to +40 (+41 to +104)	+5 bis +50 (+41 to +122)	+5 bis +50 (+41 to +122)
Water vapour tolerance with > 20 hours l/min purge gas or gas ballast	mbar (Torr)	≥ 60 (≥ 45)	≥ 60 (≥ 45)	≥ 60 (≥ 45)	≥ 60 (≥ 45)
Water vapour capacity	kg/h	25	25	25	25
Noise level at ultimate pressure with silencer	dB(A)	67	65	67	67
with permanent exhaust line	dB(A)	67	65	65	65
Power consumption at ultimate pressure	kW	≤ 9.5	≤ 7	≤ 7	≤ 7
Cooling		water	water	water	water
Electrical connection		380-480 V, 50/60 Hz	380-480 V, 50/60 Hz	380-480 V, 50/60 Hz	380-480 V, 50/60 Hz
Phases		3-ph.	3-ph.	3-ph.	3-ph.
Nominal power at 400 V	kW	21	15	15	15
Nominal current at 400 V	A	35	31	31	31
Intake connection	DN	250 ISO-K	100 ISO-K	100 ISO-K	100 ISO-K
Exhaust side connection	DN	63 ISO-K or 50 KF	63 ISO-K	63 ISO-K	63 ISO-K
Protection class EN 60529	IP	20	20	54	55
Weight	kg (lbs)	1200 (2646)	750 (1654)	580 (1279)	540 (1191)
Dimensions (W x D x H)	mm (in.)	1340 x 670 x 1105 (52.8 x 26.4 x 43.5)	1340 x 670 x 680 (52.8 x 26.4 x 26.8)	1280 x 570 x 420 (50.4 x 22.4 x 16.5)	1200 x 450 x 400 (47.2 x 17.7 x 15.7)
Cooling water connection Threads, female	G	1/2	1/2	1/2	1/2
Max. cooling water temperature	°C (°F)	5 to 35 (41 to 95)	5 to 35 (41 to 95)	5 to 35 (41 to 95)	5 to 35 (41 to 95)
Min. cooling water throughput, nominal	l/min (US gallon/min)	11 (2.9)	7.5 (2.0)	7.5 (2.0)	7.5 (2.0)
Purge gas connection (plugged connection)		D10	D10	D10	D10

## Ordering Information

### DRYVAC enduro / sprinter / champion

DRYVAC	PLC/Touch Screen/ Software	Frequency converter	Purge gas module	Gas ballast module (ambient air)	Housing and feet	Lubricant	Part No.
<b>enduro</b>							
650 S-r <sup>1)</sup>	no	external (rack)	none	manual	rubber feet	synthetic oil	112065V01
650 S-r <sup>1)</sup>	no	external (rack)	single	24 V valve	rubber feet	synthetic oil	112065V05
650 S	no	on board	none	manual	rubber feet	synthetic oil	112065V10
650 S	no	on board	single	24 V valve	rubber feet	synthetic oil	112065V15
<b>sprinter</b>							
650 S	no	on board	single	none	rubber feet	PFPE	112065V20
650 S	no	on board	none	none	base plate, castors, adjustable feet	PFPE	112065V25
650 S-i	yes	on board	single	none	housing, castors, adjustable feet	PFPE	112065V40
<b>champion</b>							
650 S	no	on board	triple	none	rubber feet	PFPE	112065V30
650 S-r, 200 V <sup>1)</sup>	no	external (rack)	triple	none	rubber feet	PFPE	112065V35
650 S-i	yes	on board	triple	none	housing, castors, adjustable feet	PFPE	112065V45
5000 RS-i	yes	on board	triple	none	housing, castors, adjustable feet	PFPE	112500V45
5000 RS-i Exhaust connection DN 50 ISO-KF	yes	on board	triple	none	housing, castors, adjustable feet	PFPE	112500V60

## Ordering Information

### Accessories

	Part No.
Profibus module for DRYVAC S/S-r	155212V
Relay module (digital output) for DRYVAC S/S-r	112005A01
Adapter DRYVAC for RUVAC 2001	112005A05
Adapter DRYVAC for RUVAC 4400/7000	112005A10
Non-return valve DRYVAC, DN 63 ISO-K <sup>2)</sup>	112005A15
Silencer DN 63 ISO-K DRYVAC and SCREWLINE SP250	119002

<sup>2)</sup> Already integrated in all S-i/RS-i versions

# Only available for purchase in North and South America

## Product CHEMROVAC AMR

### Dry Vacuum Pump

### for Chemical and Pharmaceutical Applications

## Applications

Pumps	AMR 70	AMR 140	AMR 230	AMR 350	AMR 550
<b>Typical Applications</b>					
Pharmaceuticals	■	■	■	■	■
Fine chemicals	■	■	■	■	■
Flavours and fragrances	■	■	■	■	■
Fatty acids	■	■	■	■	■

## General

The CHEMROVAC AMR pumps are not designed to the European ATEX directive (94/9/EC). They can therefore not be installed in Europe into flame

proof environments or be used to pump flammable materials. This has always to be considered if you want to export these pumps into

Europe or install it in accordance to European directives and legal requirements.

### Operating Principle

The CHEMROVAC AMR pumps are 4-stage roots pumps. Each stage consists of two rotors rotating in opposite directions inside a casing (pumping chamber) and having slight clearances against the inside wall surface of the casing and also between the rotors. In the sequence from (1) to (4) in the figures on this and the following page each phase of rotor rotation is shown. The light area in the figure shows inlet pressure regions of a stage whereas the slash area shows discharge pressure regions. The pumping principle of this pump is explained below, using a

cold wall type back flow mechanism, referring to left rotor in each figure.

As described above, compression takes place using the properly cooled gas of the same pressure as the discharge pressure, and therefore, the temperature rise inside the case is kept low. That means, gas discharged out of the discharge port A is cooled by the cold wall B, and a portion of this cooled gas is injected as a back flow cooling medium via the port C into the moving volume S for back flow compression. Therefore, the gas has a

circulating flow of A-B-C-S-A, and in the part of A-B-C the internal compression heat is continuously dissipated. By this a high-efficiency and a high pressure ratio are obtained.

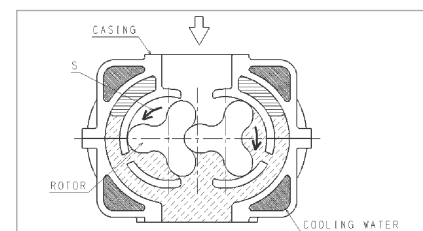
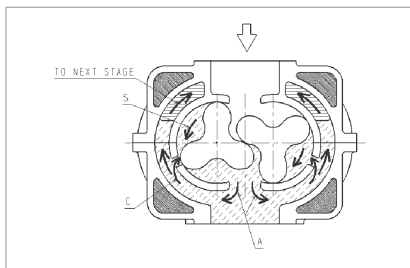
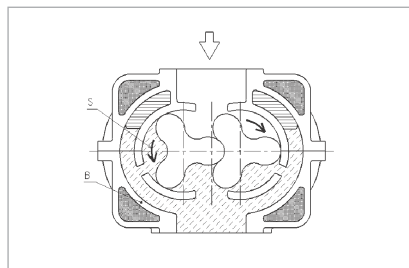

Fig. 1 This figure shows a condition just before the rotor catches the gas of the inlet pressure region into the moving volume S.



**Fig. 2**  
In this figure, the rotor has completely caught the gas of the inlet pressure region into the moving volume S. Gas which is already discharged out at exit port A is properly cooled by the cold outside wall of the gas path B. One part of this gas flows back through the port C into the moving volume S. The other part of the cooled exhausted gas is flowing into the next stage of the pump.



**Fig. 3**  
As the rotor rotates further, the gas which has been cooled properly by the cold wall B flows sufficiently into the S cavity; the pressure in the chamber S is approaching the discharge pressure.

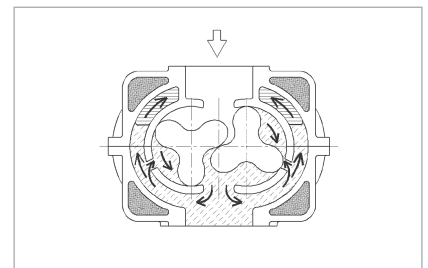

**Fig. 4**  
In this condition the pressure in the moving volume portion S is approximately equal to the discharge pressure, and the discharge port A and the cavity S are just before opening to each other.

Moreover, because the casing enclosing the rotors is not cooled directly, the clearances between the rotor and the casing is not reduced due to heat contraction, reducing the possibility of contact between both.

In some cases condensable gas can condense in the different stages according to its vapor pressure. Condensate either condensed in the pump or as liquid carry over from the process will

flow down with the gas stream and discharged to atmosphere in an exhaust drain tank.

The exhaust drain tank is mounted at the exhaust of the last pump stage. It is located either below the exhaust cooler (large pumps) or pump outlet flange (small pumps). It collects liquid condensed from the pump or the exhaust cooler.

The larger pumps are equipped with a water cooled exhaust cooler as standard. The cooler is designed as shell and tube cooler. This reduces the exhaust gas temperature to an acceptable limit. Also vapors from the exhaust gas stream are partially condensed. Condensed liquid is drained into the exhaust drain tank below the condenser.

### Advantages to the User

- Oil free compression
- Reliable separation between swept volume and gear box side (avoiding of oil back streaming)
- Motor not on gear box side, no oil leaking by motor shaft
- Safe separation of motor and gear box area by additional shaft seal purge
- Materials of construction suitable for most chemicals to be pumped
- Flat speed curve from atmosphere to 10 mbar (7.5 Torr)
- Good liquid handling because of vertical orientation
- Easy access of swept volume for cleaning
- Easy to equip with local certified flame proof motor
- Nearly no electrical control for standard operation needed

### Typical Applications

- Distillation
- Drying
- Freeze drying
- Degassing
- Central house vacuum
- Crystallisation
- Evaporation

### Accessories

As standard accessory an exhaust silencer is available for each pump.

The pumps can be combined with mechanical roots blowers to increase pumping speed and to achieve lower ultimate pressure.

CHEMROVAC AMR pumps can also be the basic part of a bespoke system that complies to special process requirements to customer's needs.

### Supplied Equipment

The basic pump CHEMROVAC AMR is a pump without a motor. A suitable motor complying with the local regulations will normally be mounted by Oerlikon Leybold Vacuum. In this case the CHEMROVAC AMR is supplied ready for installation and connection.

In some cases the motor will be delivered and mounted by the end-user. In this case the user is responsible for correct selection and safe mounting of the motor. OLV will not take over any responsibility for the motor and motor mounting in such a case.

The electrical connections to the pump must be provided by suitably trained staff of the customer.

The basic CHEMROVAC AMR pump is delivered with:

- Nitrogen shaft seal purge unit
- The required amount of gear oil (is supplied separately)
- 2 crane eyes for transporting the pump
- Operating Instructions

# Products

## CHEMROVAC AMR 70 to 550

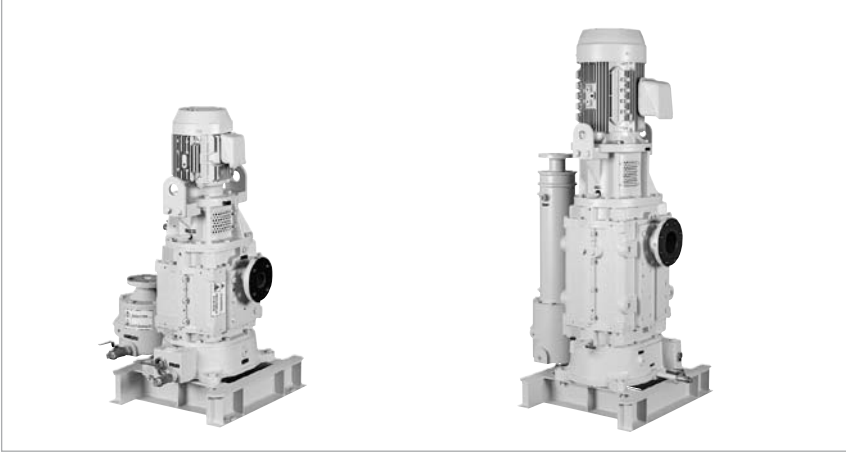

CHEMROVAC AMR 70 (left) and AMR 550 (right)

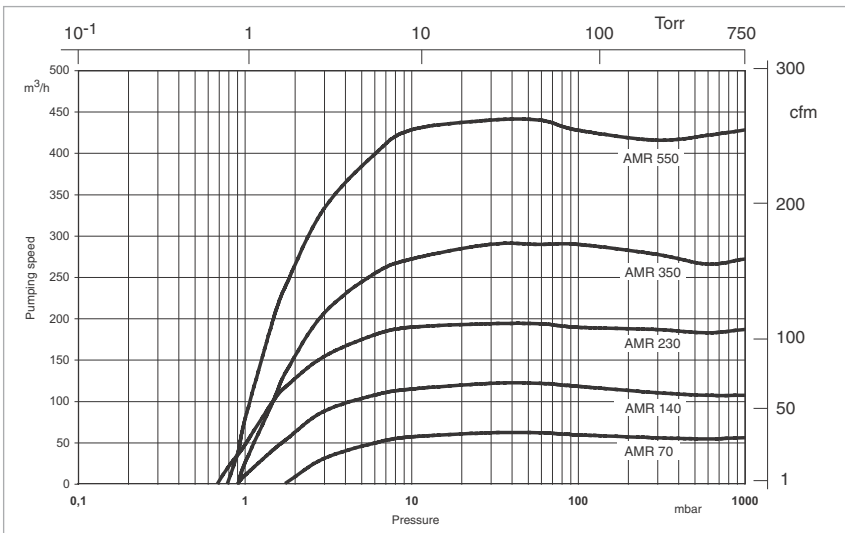

Pumping speed curves for the CHEMROVAC AMR at 50 Hz

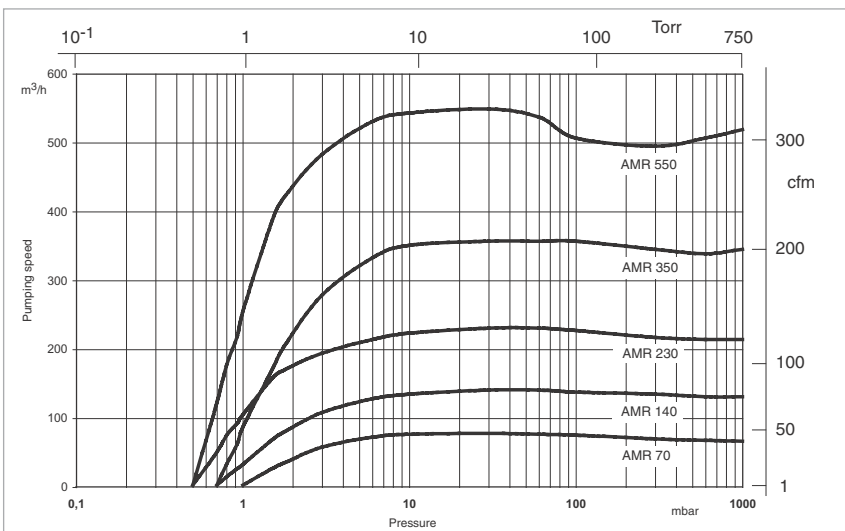

Pumping speed curves for the CHEMROVAC AMR at 60 Hz

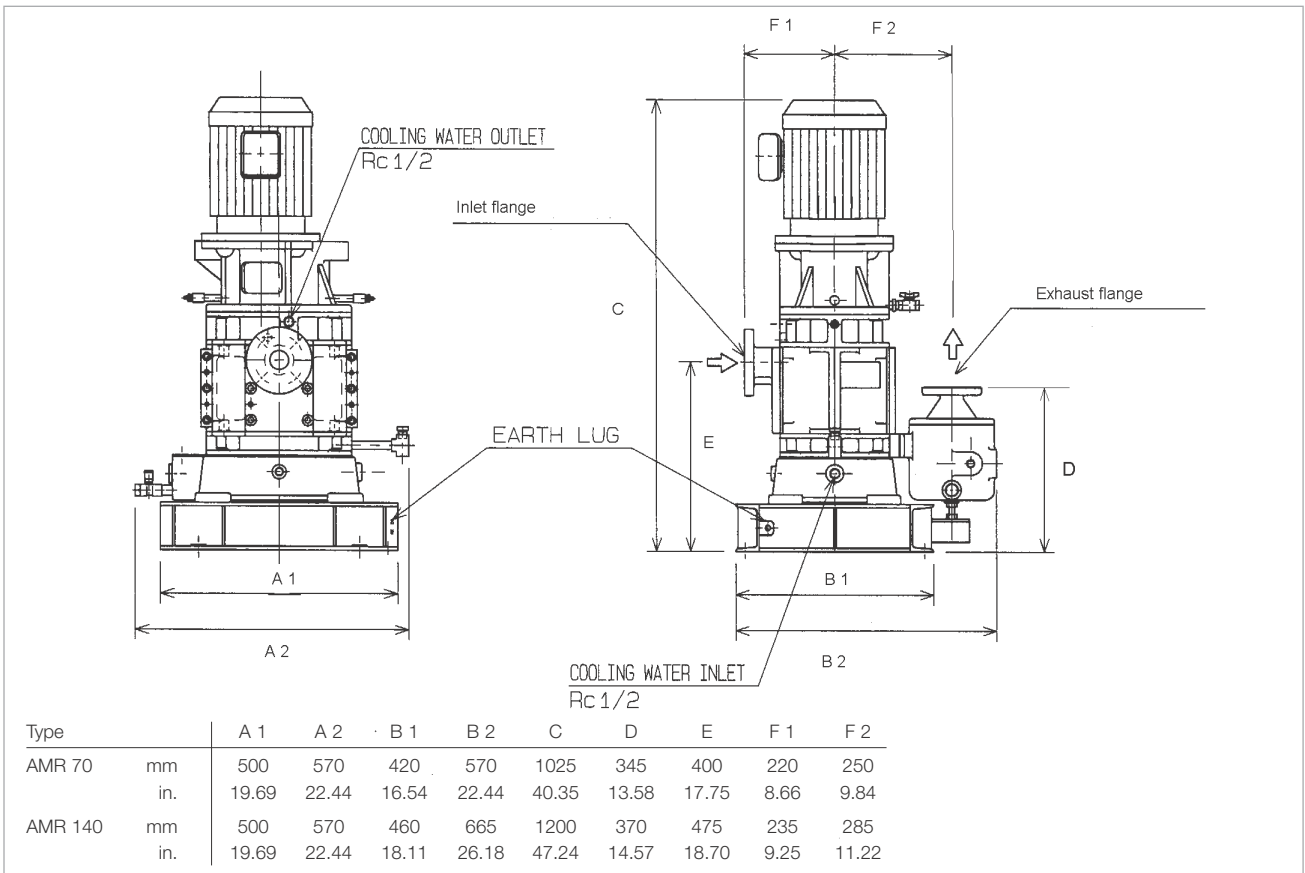

Dimensional drawing of the CHEMROVAC AMR 70 and 140

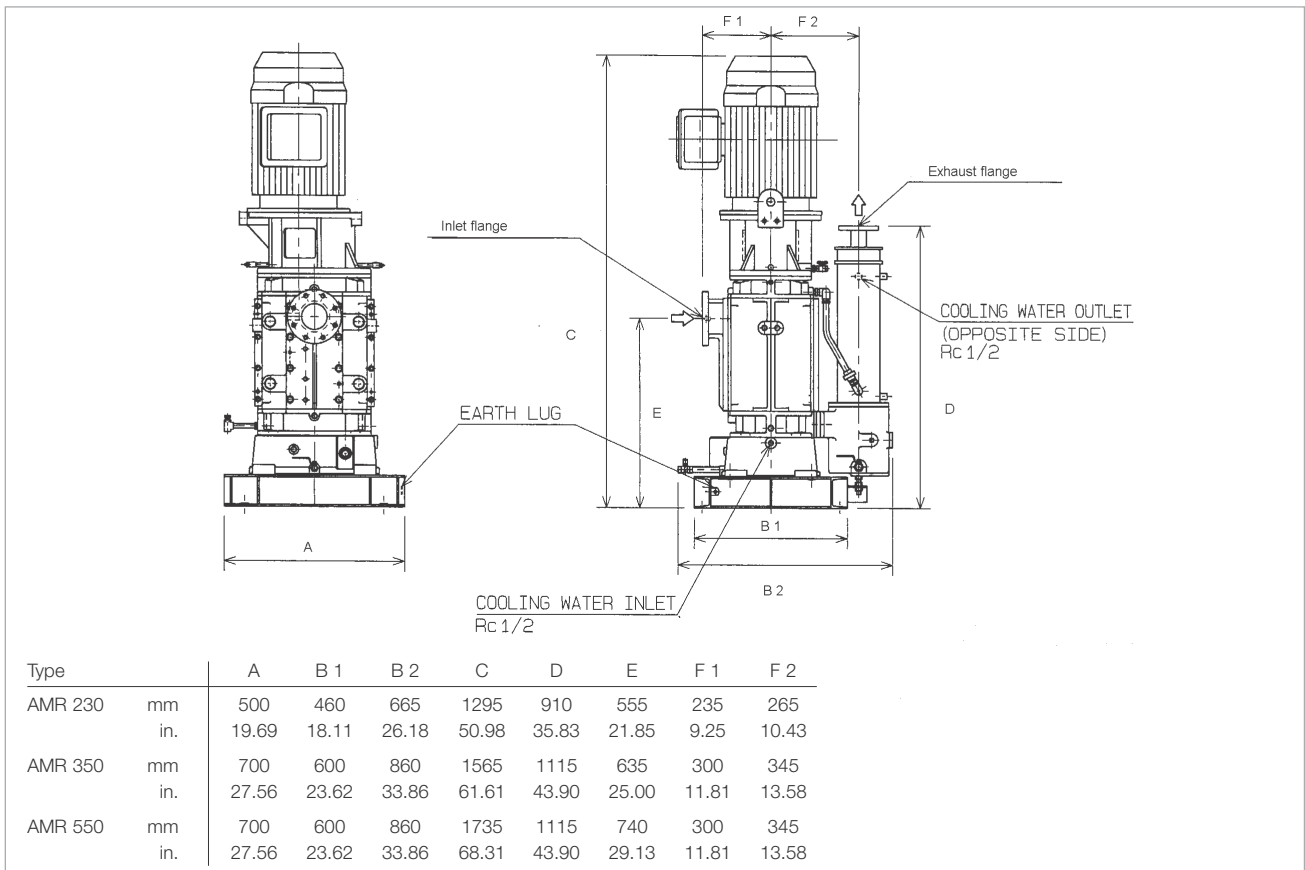

Dimensional drawing of the CHEMROVAC AMR 230 to 550

## Technical Data

## CHEMROVAC

		AMR 70	AMR 140	AMR 230	AMR 350	AMR 550
<b>Max. pumping speed (+/- 10%)</b>						
60 Hz	m <sup>3</sup> x h <sup>-1</sup> (cfm)	75 (44)	138 (81)	228 (134)	354 (208)	546 (321)
50 Hz	m <sup>3</sup> x h <sup>-1</sup> (cfm)	60 (36)	120 (71)	192 (113)	288 (170)	438 (258)
<b>Ultimate total pressure, abs.</b>						
60 Hz	mbar (Torr)	1.0 (0.75)	0.7 (0.53)	0.5 (0.38)	0.7 (0.53)	0.5 (0.38)
50 Hz	mbar (Torr)	1.8 (1.35)	0.9 (0.68)	0.7 (0.53)	0.9 (0.68)	0.8 (0.60)
<b>Max. permissible exhaust back pressure, abs.</b>	mbar (Torr)	900 to 1200 (575 to 900)	900 to 1200 (575 to 900)	900 to 1200 (575 to 900)	900 to 1200 (575 to 900)	900 to 1200 (575 to 900)
<b>Max. permissible inlet pressure, abs.</b>	mbar (Torr)	1050 (788)	1050 (788)	1050 (788)	1050 (788)	1050 (788)
<b>Max. permissible inlet temperature</b>	°C (°F)	50 (122)	50 (122)	50 (122)	50 (122)	50 (122)
<b>Permissible ambient temperature for constant operation <sup>1)</sup></b>	°C (°F)	-20 to +40 (-4 to +104)	-20 to +40 (-4 to +104)	-20 to +40 (-4 to +104)	-20 to +40 (-4 to +104)	-20 to +40 (-4 to +104)
<b>Max. relative ambient moisture</b>	%	up to 90	up to 90	up to 90	up to 90	up to 90
<b>Max. permissible installation height</b>	m (ft)	up to 1000 (up to 3280)	up to 1000 (up to 3280)	up to 1000 (up to 3280)	up to 1000 (up to 3280)	up to 1000 (up to 3280)
<b>Sound pressure with silencer at ultimate (± 3 dB(A))</b>						
60 Hz	dB(A)	76	79	81	81	82
50 Hz	dB(A)	73	75	77	78	79
<b>Process flange size</b>						
inlet	ANSI / lb ff	1 1/2" / 125	2" / 125	2 1/2" / 125	3" / 125	4" / 125
outlet	ANSI / lb ff	1 1/2" / 125	1 1/2" / 125	2 1/2" / 125	2 1/2" / 125	2 1/2" / 125
<b>Cooling water flange size</b>						
inlet	Rc	1/2"	1/2"	1/2"	1/2"	1/2"
outlet	Rc	1/2"	1/2"	1/2"	1/2"	1/2"
<b>Shaft seal purge gas size</b>	Rc	3/8"	3/8"	3/8"	3/8"	3/8"
<b>Recommended shaft seal purge flow</b>						
gear side	l/min (gallon/min)	3.0 (0.8)	5.0 (1.3)	5.0 (1.3)	6.0 (1.6)	6.0 (1.6)
motor side	l/min (gallon/min)	0,5 (0.15)	1.0 (0.3)	1.0 (0.3)	2.0 (0.6)	2.0 (0.6)
<b>Type of gas</b>		nitrogen	nitrogen	nitrogen	nitrogen	nitrogen
<b>Dew point of supply gas</b>	°C (°F)	-15 (+5)	-15 (+5)	-15 (+5)	-15 (+5)	-15 (+5)
<b>Maximum particle size in gas</b>	µm	3	3	3	3	3
<b>Weight without motor</b>	kg (lbs)	180 (397)	235 (520)	280 (617)	535 (1180)	590 (1300)
<b>Assumed weight with motor</b>	kg (lbs)	235 (520)	319 (705)	396 (875)	708 (1560)	816 (1800)

<sup>1)</sup> If you operate the pump in an ambient temperature between -20 and +5 °C (-4 to +41 °F) we recommend that you leave the pump constantly operating and only shut down the pump for maintenance purposes. The pump must be pre-warmed if you want to start it in an ambient temperature range between -20 and +5 °C (-4 to +41 °F).

## Additional Technical Data

## CHEMROVAC

		AMR 70	AMR 140	AMR 230	AMR 350	AMR 550
Motor flame proof protection		to local standards, e.g. class 1, division 1, C&D, or Ex d IIB				
Start-up method		direct on line or via frequency converter				
Voltage	V	depending on local requirements				
Installed power						
60 Hz	kW (HP)	3.7 (5.0)	5.5 (7.5)	7.5 (10.0)	15.0 (20.0)	18.5 (25.0)
50 Hz	kW (HP)	3.7 (5.0)	5.5 (7.5)	7.5 (10.0)	15.0 (20.0)	18.5 (25.0)
Absorbed power at ultimate pressure						
60 Hz	kW (HP)	2.1 (2.8)	3.3 (4.4)	4.8 (6.4)	9.0 (12.1)	12.5 (16.8)
50 Hz	kW (HP)	1.8 (2.4)	3.0 (4.0)	4.1 (5.5)	7.0 (9.4)	10.0 (13.4)
Motor frame size	NEMA	184TC	213TC	215TC	256TC	284TSC
	IEC	112 M	132 S	132 S	160 M	160 L
No. of phases		3	3	3	3	3
No. of poles		2	2	2	2	2
Motor frequency	Hz	50 or 60, depending on local conditions				
Operating frequency	Hz	26 to 60				
Nominal revolution	1/min	3000 or 3600, depending on motor frequency				
Cooling		water, direct without temperature control valve				
Minimum cooling water consumption (at 25 °C (77 °F) inlet temperature)						
60 Hz	l/min (gallon/min)	5.0 (1.3)	7.0 (1.9)	10.0 (2.7)	20.0 (5.3)	28.0 (7.4)
50 Hz	l/min (gallon/min)	5.0 (1.3)	7.0 (1.9)	10.0 (2.7)	20.0 (5.3)	28.0 (7.4)
Cooling water temperature	°C (°F)	+10 to +35 (+50 to +95)	+10 to +35 (+50 to +95)	+10 to +35 (+50 to +95)	+10 to +35 (+50 to +95)	+10 to +35 (+50 to +95)
Cooling water supply pressure, abs.	bar (psi)	3 to 7 (44 to 102)	3 to 7 (44 to 102)	3 to 7 (44 to 102)	3 to 7 (44 to 102)	3 to 7 (44 to 102)
Lubrication bearing						
motor side (grease)	ml	100	200	200	260	260
gear side (oil)		depends on oil capacity				
Oil type for gear box		LVO 130	LVO 130	LVO 130	LVO 130	LVO 130
Volume gear box oil	l (gallon)	1.0 (0.3)	1.0 (0.3)	1.0 (0.3)	4.0 (1.1)	4.0 (1.1)

## Ordering Information

## CHEMROVAC

	AMR 70	AMR 140	AMR 230	AMR 350	AMR 550
	<b>Part No.</b>	<b>Part No.</b>	<b>Part No.</b>	<b>Part No.</b>	<b>Part No.</b>
Dry vacuum pump					
for chemical and pharmaceutical application					
CHEMROVAC AMR (without motor)	<b>134 101</b>	<b>134 102</b>	<b>134 103</b>	<b>134 104</b>	<b>134 105</b>
CHEMROVAC AMR (with NEMA motor Class 1, Div. 1, Group C & D, 230/460 V, 60 Hz)	<b>134 201 V</b>	<b>134 202 V</b>	<b>134 203 V</b>	<b>134 204 V</b>	<b>134 205 V</b>
Accessories					
Exhaust silencer, filled with mineral wool	<b>134 121</b>	<b>134 121</b>	<b>134 122</b>	<b>134 122</b>	<b>134 122</b>

# Sales and Service

## Germany

**Oerlikon**  
**Leybold Vacuum GmbH**  
Bonner Strasse 498  
D-50968 Cologne  
Phone: +49-(0)221-347 1234  
Fax: +49-(0)221-347 1245  
sales.vacuum@oerlikon.com  
www.oerlikon.com

**Oerlikon**  
**Leybold Vacuum GmbH**  
**Sales Area North/Northeast**  
Branch Office Berlin  
Industriestrasse 10b  
D-12099 Berlin  
Phone: +49-(0)30-435 609 0  
Fax: +49-(0)30-435 609 10  
sales.vacuum.bn@oerlikon.com

**Oerlikon**  
**Leybold Vacuum GmbH**  
**Sales Area South/Southwest**  
Branch Office Munich  
Karl-Hammerschmidt-Strasse 34  
D-85609 Aschheim-Dornach  
Phone: +49-(0)89-357 33 9-10  
Fax: +49-(0)89-357 33 9-33  
sales.vacuum.mn@oerlikon.com  
service.vacuum.mn@oerlikon.com

**Oerlikon**  
**Leybold Vacuum GmbH**  
**Sales Area West & Benelux**  
Branch Office Cologne  
Bonner Strasse 498  
D-50968 Cologne  
Phone: +49-(0)221-347 1270  
Fax: +49-(0)221-347 1291  
sales.vacuum.kn@oerlikon.com

**Oerlikon**  
**Leybold Vacuum GmbH**  
**Service Competence Center**  
Emil-Hoffmann-Strasse 43  
D-50996 Cologne-Suerth  
Phone: +49-(0)221-347 1538  
Fax: +49-(0)221-347 1945  
service.vacuum.kn@oerlikon.com

**Oerlikon**  
**Leybold Vacuum GmbH**  
**Mobil Customer Service**  
Emil-Hoffmann-Strasse 43  
D-50996 Cologne-Suerth  
Phone: +49-(0)221-347 2001  
Fax: +49-(0)221-347 1944  
service.vacuum.kn@oerlikon.com

**Oerlikon**  
**Leybold Vacuum**  
**Dresden GmbH**  
**Service Competence Center**  
Zur Wetterwarte 50, Haus 304  
D-01109 Dresden  
Service:  
Phone: +49-(0)351-88 55 00  
Fax: +49-(0)351-88 55 041  
info.vacuum.dr@oerlikon.com

**Oerlikon**  
**Leybold Vacuum USA Inc.**  
5700 Mellon Road  
USA-Export, PA 15632  
Phone: +1-724-327-5700  
Fax: +1-724-325-3577  
info.vacuum.ex@oerlikon.com

## Europe

Belgium  
**Oerlikon**  
**Leybold Vacuum Nederland B.V.**  
**Belgisch bijkantoor**  
Leuvensesteenweg 542-9A  
B-1930 Zaventem  
Sales:  
Phone: +32-2-711 00 83  
Fax: +32-2-720 83 38  
sales.vacuum.zv@oerlikon.com  
Service:  
Phone: +32-2-711 00 82  
Fax: +32-2-720 83 38  
service.vacuum.zv@oerlikon.com

France  
**Oerlikon**  
**Leybold Vacuum France S.A.**  
7, Avenue du Québec  
Z.A. de Courtaboeuf 1 - B.P. 42  
F-91942 Courtaboeuf Cedex  
Sales and Service:  
Phone: +33-1-69 82 48 00  
Fax: +33-1-69 07 57 38  
info.vacuum.ctb@oerlikon.com  
sales.vacuum.ctb@oerlikon.com

**Oerlikon**  
**Leybold Vacuum France S.A.**  
**Valence Factory**  
640, Rue A. Bergès  
B.P. 107 640  
F-26501 Bourg-lès-Valence Cedex  
Service:  
Phone: +33-4-75 82 33 00  
Fax: +33-4-75 82 92 69  
marketing.vacuum.vc@oerlikon.com

Great Britain  
**Oerlikon**  
**Leybold Vacuum UK LTD.**  
Silverglade Business Park  
Leatherhead Road Unit 2  
KT9 2QL Chessington, Surrey  
(London)  
Sales:  
Phone: +44-13-7273 7300  
Fax: +44-13-7273 7301  
sales.vacuum.ln@oerlikon.com  
Service:  
Phone: +44-20-8971 7030  
Fax: +44-20-8971 7003  
service.vacuum.ln@oerlikon.com

Italy  
**Oerlikon**  
**Leybold Vacuum Italia S.r.l.**  
Via Trasimeno 8  
I-20128 Milano  
Sales:  
Phone: +39-02-27 22 31  
Fax: +39-02-27 20 96 41  
sales.vacuum.mi@oerlikon.com  
Service:  
Phone: +39-02-27 22 31  
Fax: +39-02-27 22 31 7  
service.vacuum.mi@oerlikon.com

Spain  
**Oerlikon**  
**Leybold Vacuum Spain, S.A.**  
C/ Huelva 7  
E-08940 Cornellà de Llobregat  
(Barcelona)  
Sales:  
Phone: +34-93-666 43 11  
Fax: +34-93-666 43 70  
sales.vacuum.ba@oerlikon.com  
Service:  
Phone: +34-93-666 46 16  
Fax: +34-93-685 43 70  
service.vacuum.ba@oerlikon.com

Netherlands  
**Oerlikon**  
**Leybold Vacuum Nederland B.V.**  
Proostwetering 24N  
NL-3543 AE Utrecht  
Sales and Service:  
Phone: +31-(30) 242 6330  
Fax: +31-(30) 242 6331  
sales.vacuum.ut@oerlikon.com  
service.vacuum.ut@oerlikon.com

Switzerland  
**Oerlikon**  
**Leybold Vacuum Schweiz AG**  
Leutschenbachstrasse 55  
CH-8050 Zürich  
Sales:  
Phone: +41-44-308 40 50  
Fax: +41-44-302 43 73  
sales.vacuum.zh@oerlikon.com  
Service:  
Phone: +41-44-308 40 62  
Fax: +41-44-308 40 60  
service.vacuum.zh@oerlikon.com

Switzerland  
**Oerlikon**  
**Leybold Vacuum Schweiz AG**  
Leutschenbachstrasse 55  
CH-8050 Zürich  
Sales:  
Phone: +41-44-308 40 50  
Fax: +41-44-302 43 73  
sales.vacuum.zh@oerlikon.com  
Service:  
Phone: +41-44-308 40 62  
Fax: +41-44-308 40 60  
service.vacuum.zh@oerlikon.com

## America

**Oerlikon**  
**Leybold Vacuum USA Inc.**  
5700 Mellon Road  
USA-Export, PA 15632  
Phone: +1-724-327-5700  
Fax: +1-724-325-3577  
info.vacuum.ex@oerlikon.com  
Sales:  
Eastern & Central time zones  
Phone: +1-724-327-5700  
Fax: +1-724-333-1217  
Pacific, Mountain, Alaskan &  
Hawaiian time zones  
Phone: +1-408-436-2828  
Fax: +1-408-436-2849  
Service:  
Phone: +1-724-327-5700  
Fax: +1-724-325-3577

**Oerlikon**  
**Leybold Vacuum (Tianjin)**  
**International Trade Co. Ltd.**  
Beijing Branch:  
1-908, Beijing Landmark Towers  
8 North Dongsanhuan Road  
Beijing 100004  
China  
Sales:  
Phone: +86-10-6590-7622  
Fax: +86-10-6590-7607  
sales.vacuum.bj@oerlikon.com  
service.vacuum.bj@oerlikon.com

India  
**Oerlikon**  
**Leybold Vacuum India Pvt Ltd.**  
EL 22, J-Block  
MIDC Bhosari  
Pune 411026  
India  
Sales and Service:  
Phone: +91-20-3061 6000  
Fax: +91-20-2712 1571  
sales.vacuum.pu@oerlikon.com  
service.vacuum.pu@oerlikon.com

**Oerlikon**  
**Leybold Vacuum GmbH**  
Bonner Strasse 498  
D-50968 Cologne  
Phone: +49-(0)221-347 0  
Fax: +49-(0)221-347 1250  
info.vacuum@oerlikon.com

## Asia

P.R. China  
**Oerlikon**  
**Leybold Vacuum (Tianjin)**  
**International Trade Co. Ltd.**  
Beichen Economic  
Development Area (BEDA),  
No.8 Western Shuangchen Road  
Tianjin 300400  
China  
Sales and Service:  
Phone: +86-22-2697 0808  
Fax: +86-22-2697 4061  
Fax: +86-22-2697 2017  
info.vacuum.tj@oerlikon.com  
sales.vacuum.tj@oerlikon.com  
service.vacuum.tj@oerlikon.com

**Oerlikon**  
**Leybold Vacuum**  
**(Tianjin) Co. Ltd.**  
Beichen Economic  
Development Area (BEDA),  
No.8 Western Shuangchen Road  
Tianjin 300400  
China  
Sales and Service:  
Phone: +86-22-2697 0808  
Fax: +86-22-2697 4061  
info.vacuum.tj@oerlikon.com  
sales.vacuum.tj@oerlikon.com  
service.vacuum.tj@oerlikon.com

**Oerlikon**  
**Leybold Vacuum (Tianjin)**  
**International Trade Co. Ltd.**  
Shanghai Branch:  
No.33  
76 Fu Te Dong San Road  
Waigaoqiao Free Trade Zone  
Shanghai 200131  
China  
Sales and Service:  
Phone: +86-21-5064-4666  
Fax: +86-21-5064-4668  
info.vacuum.sh@oerlikon.com  
sales.vacuum.sh@oerlikon.com  
service.vacuum.sh@oerlikon.com

**Oerlikon**  
**Leybold Vacuum (Tianjin)**  
**International Trade Co. Ltd.**  
Guangzhou Office and  
Service Center  
1st F, Main Building  
Science City Plaza,  
No.111 Science Revenue,  
Guangzhou Science City  
(GZSC) 510663, Guangzhou,  
China  
Sales:  
Phone: +86-20-223 23 980  
Fax: +86-20-223 23 990  
info.vacuum.gz@oerlikon.com  
sales.vacuum.gz@oerlikon.com  
service.vacuum.gz@oerlikon.com

**Oerlikon**  
**Leybold Vacuum (Tianjin)**  
**International Trade Co. Ltd.**  
Beijing Branch:  
1-908, Beijing Landmark Towers  
8 North Dongsanhuan Road  
Beijing 100004  
China  
Sales:  
Phone: +86-10-6590-7622  
Fax: +86-10-6590-7607  
sales.vacuum.bj@oerlikon.com  
service.vacuum.bj@oerlikon.com

India  
**Oerlikon**  
**Leybold Vacuum India Pvt Ltd.**  
EL 22, J-Block  
MIDC Bhosari  
Pune 411026  
India  
Sales and Service:  
Phone: +91-20-3061 6000  
Fax: +91-20-2712 1571  
sales.vacuum.pu@oerlikon.com  
service.vacuum.pu@oerlikon.com

Japan  
**Oerlikon**  
**Leybold Vacuum**  
**Japan Co., Ltd.**  
Headquarter  
23-3, Shin-Yokohama  
3-chome  
Tobu A.K. Bldg. 4th Floor  
Kohoku-ku  
Yokohama-shi 222-0033  
Sales:  
Phone: +81-45-471-3330  
Fax: +81-45-471-3323  
info.vacuum.yh@oerlikon.com  
sales.vacuum.yh@oerlikon.com

**Oerlikon**  
**Leybold Vacuum**  
**Japan Co., Ltd.**  
Osaka Sales Office  
3F, Shin-Osaka Terasaki  
No.3 Bldg.  
1-5-28 Nishi-Miyahara  
Yodogawa-ku, Osaka-shi  
Osaka 532-0004  
Phone: +81-6-6399-6271  
Fax: +81-6-6399-6273  
info.vacuum.os@oerlikon.com  
sales.vacuum.os@oerlikon.com

**Oerlikon**  
**Leybold Vacuum**  
**Japan Co., Ltd.**  
Tsukuba Technical Service Center  
Kogyo Danchi  
21, Kasuminosato,  
Ami-machi, Inashiki-gun  
Ibaraki-ken, 300-0315  
Service:  
Phone: +81-298 89 2841  
Fax: +81-298 89 2838  
info.vacuum.iik@oerlikon.com  
sales.vacuum.iik@oerlikon.com

South Korea  
**Oerlikon**  
**Leybold Vacuum Korea Ltd.**  
3F, Jellzone 2 Tower  
Jeongja-dong 159-4  
Bundang-gu Sungnam-si  
Gyeonggi-do  
Bundang 463-384, Korea  
Sales:  
Phone: +82-31 785 1367  
Fax: +82-31 785 1359  
sales.vacuum.bd@oerlikon.com

Service:  
623-7, Upsung-Dong  
Cheonan-Si  
Chungcheongnam-Do  
Korea 330-290  
Phone: +82-41 589 3035  
Fax: +82-41 588 0166  
service.vacuum.cn@oerlikon.com

Singapore  
**Oerlikon**  
**Leybold Vacuum**  
**Singapore Pte Ltd.**  
1 Science Park Road  
Singapore Science Park 2  
#02-12, Capricorn Building  
Singapore 117528  
Sales and Service:  
Phone: +65-6303 7030  
Fax: +65-6773 0039  
sales.vacuum.sg@oerlikon.com  
service.vacuum.sg@oerlikon.com

Taiwan  
**Oerlikon**  
**Leybold Vacuum Taiwan Ltd.**  
No 416-1, Sec. 3  
Chungshin Road., Chutung  
Hsinchu County 310  
Taiwan, R.O.C.  
Sales and Service:  
Phone: +886-3-500 1688  
Fax: +886-3-583 3999  
sales.vacuum.hc@oerlikon.com  
service.vacuum.hc@oerlikon.com

**oerlikon**  
leybold vacuum