

# TELEDYNE HASTINGS INSTRUMENTS



## INSTRUCTION MANUAL

HFM-301/305/306  
FLOW METERS  
HFC-303/307 FLOW  
CONTROLLERS



# Manual Print History

The print history shown below lists the printing dates of all revisions and addenda created for this manual. The revision level letter increases alphabetically as the manual undergoes subsequent updates. Addenda, which are released between revisions, contain important change information that the user should incorporate immediately into the manual. Addenda are numbered sequentially. When a new revision is created, all addenda associated with the previous revision of the manual are incorporated into the new revision of the manual. Each new revision includes a revised copy of this print history page.

Revision G (Document Number 152-102002)	October 2002
Revision H (Document Number 152-082005)	August 2005
Revision J (Document Number 152-042006)	March 2006
Revision K (Document Number 152-062008)	June 2008
Revision L (Document Number 152-082008)	August 2008
Revision M (Document Number 152-082009)	August 2009
Revision N (Document Number 152-102009)	October 2009
Revision P (Document Number 152-082010)	August 2010
Revision Q (Document Number 152-052012)	May 2012
Revision R (Document Number 152-072014)	July 2014
Revision S (Document Number 152-032015)	March 2015



**Visit [www.teledyne-hi.com](http://www.teledyne-hi.com) for WEEE disposal guidance.**



**CAUTION:**

The instruments described in this manual are available with multiple pin-outs. Ensure that all electrical connections are correct.



**CAUTION:**

The instruments described in this manual are designed for INDOOR use only.



**CAUTION:**

The instruments described in this manual are designed for Class 2 installations in accordance with IAW/IPC standards

---

Hastings Instruments reserves the right to change or modify the design of its equipment without any obligation to provide notification of change or intent to change.

---

# Table of Contents

<b>1. GENERAL INFORMATION.....</b>	<b>4</b>
1.1. FEATURES .....	4
1.2. SPECIFICATIONS .....	5
OPTIONAL 4-20 mA CURRENT OUTPUT.....	6
1.3. OTHER ACCESSORIES.....	6
<b>2. OPERATION.....</b>	<b>7</b>
2.1. RECEIVING INSPECTION .....	7
2.2. POWER REQUIREMENTS .....	7
2.3. OUTPUT SIGNAL.....	7
2.4. MECHANICAL CONNECTIONS.....	7
2.5. ELECTRICAL CONNECTIONS.....	8
2.6. 4 – 20 mA CONNECTIONS.....	10
2.7. OPERATION.....	11
2.8. RANGE CHANGING.....	15
2.9. OUTPUT FILTER .....	15
2.10. CONTROLLING OTHER PROCESS VARIABLES .....	15
2.11. COMMAND INPUT.....	16
2.12. VALVE OVERRIDE CONTROL .....	16
2.13. GAIN POTENTIOMETER .....	16
2.14. TEMPERATURE COEFFICIENTS .....	16
<b>3. MAINTENANCE.....</b>	<b>17</b>
3.1. AUTHORIZED MAINTENANCE.....	17
3.2. TROUBLESHOOTING .....	17
3.3. ADJUSTMENTS .....	18
3.4. END CAP REMOVAL .....	19
3.5. PRINTED CIRCUIT BOARD AND SENSOR REPLACEMENT.....	19
<b>4. WARRANTY .....</b>	<b>21</b>
4.1. WARRANTY REPAIR POLICY .....	21
4.2. NON-WARRANTY REPAIR POLICY .....	21
<b>5. APPENDIX .....</b>	<b>22</b>
5.1. APPENDIX 1- VOLUMETRIC VERSUS MASS FLOW.....	22
5.2. APPENDIX 2 - GAS CONVERSION FACTORS .....	23

# 1. General Information

The Hastings 300 Series high range mass flow meters are designed to accurately measure mass flow at a range between 25 slm and 10000 slm. The Hastings 300 Series high range mass flow controllers are designed to accurately measure and control mass flow at a range between 25 slm and 2500 slm. These instruments are intrinsically linear and have an accuracy of better than  $\pm 1\%$  F.S. (full scale). The Hastings 300 Series high range mass flow instruments determine the flow rate by measuring the rate of heat transfer between two wound thermal coils on a small diameter sensor tube. This heat transfer measurement is fairly insensitive to changes in system pressure and temperature; however small changes in the constant pressure specific heat do occur for most gases when the pressure and temperature are changed by a large amount. These effects are documented elsewhere in this product manual.

Hastings mass flow instruments do not require any periodic maintenance under normal operating conditions with clean gases. No damage will occur from the use of moderate overpressures (~500 psi/3.45MPa) or overflows. Instruments are normally calibrated with the appropriate standard calibration gas (nitrogen) then a correction factor is used to adjust the output for the intended gas. Calibrations for other gases, such as oxygen, helium and argon, are available upon special order.

## 1.1. Features

- **LINEAR BY DESIGN.** The HFM-301/305/306 and HFC-303/307 series is intrinsically linear (no linearization circuitry is employed). Should recalibration (a calibration standard is required) in the field be desired, the customer needs to simply set the zero and span points. There will be no appreciable linearity change of the instrument when the flowing gas is changed.
- **NO FOLD OVER.** The output signal is linear for very large over flows and is monotonically increasing thereafter. The output signal will not come back on scale when flows an order of magnitude over the full scale flow rate are measured. This means no false acceptable readings during leak testing.
- **MODULAR SENSOR.** The HFM-301/305/306 and HFC-303/307 series incorporates a removable/replaceable sensor module. Field repairs to units can be achieved with a minimum of production line downtime. Calibration is required.
- **FAST SETTLING TIME.** Changes in flow rate are detected in less than 500 milli-seconds when using the standard factory PC board settings. Controller response is typically < 2 seconds.
- **LOW TEMPERATURE DRIFT.** The temperature coefficient of span for the HFM-301/HFC-303 series is less than 0.08% of full scale/ $^{\circ}\text{C}$  from -20-70 $^{\circ}\text{C}$ . The temperature coefficient of zero is less than 0.12% of reading/ $^{\circ}\text{C}$  from -20-70 $^{\circ}\text{C}$ .
- **FIELD RANGEABLE.** The HFM-305 and HFC-307 are available in ranges from 1000 slm to 2500 slm. The HFM-301 and HFC-303 are available from 25-1000 slm. Each flow meter has a shunt and transducer which can be exchanged in the field to select different ranges. Calibration, however, is required.
- **CURRENT LOOP.** The 4-20 mA option gives the user the advantages of a current loop output to minimize environmental noise pickup.

## 1.2. Specifications

Accuracy .....	HFM-301/305 & HFC-303/307: $\pm 1\%$ full scale (F.S.) HFM-306; $\pm 2\%$ full scale (F.S.)
Repeatability (includes noise) .....	$\pm 0.2\%$ of F.S.
Maximum pressure .....	500 psi [3.45 MPa] 300 psi (HFM-306)
Maximum pressure with High Pressure option .....	1000 psi [6.9 MPa] (HFM-301/HFC303 only)
Pressure coefficient.....	$< 0.016\%$ of reading/psi (N2) See pressure section for more information
Operating temperature .....	-20 - 70°C in non-condensing environment
Temperature coefficient (zero) .....	maximum $\pm 0.12\%$ (F.S.)/°C (-20-70°C)
Temperature coefficient (span) .....	maximum $\pm 0.08\%$ Reading/°C (-20-70°C)
Leak integrity.....	$< 1 \times 10^{-9}$ std. cc/s.
Standard output .....	0 - 5 VDC (load min 2k Ohms)
Optional output .....	4 - 20 mA. (load $< 600$ Ohms)
Power requirements.....	$\pm (14 - 16)$ VDC @ 70 mA (meters) $\pm (14 - 16)$ VDC @ 185 mA (controller) Class 2 power 150VA max
Wetted materials .....	302/304 & 316 stainless steel, nickel 200, Viton Kalrez® (controller only)
Attitude sensitivity of zero .....	$< \pm 1.4\%$ F.S. for 90° without re-zeroing (N2 at 50 psig [446 KPa])
Weight.....	HFM-301; 3.5 lbs. (1.6 kg) HFC-303; 5.3 lbs. (2.4 kg) HFM-305; 8.1 lbs. (3.7 kg) HFM-306; 28.8 lbs. (13.1 kg) HFC-307; 15.2 lbs. (6.9 kg)
Electrical connector.....	15 pin subminiature "D"
Available fitting options (all tube fittings are 2 piece compression fittings)	
HFM-301/HFC-303: .....	$\frac{1}{2}$ " Tube, $\frac{3}{4}$ " tube, $\frac{1}{2}$ " Male NPT, $\frac{3}{8}$ " Male NPT $\frac{1}{2}$ " VCR®, $\frac{1}{2}$ " VCO®, 10 mm tube, 12 mm tube, 20 mm tube Surface Mount (HFM-301 small base only), $\frac{3}{4}$ " VCR®, $\frac{3}{4}$ " VCO® $\frac{3}{4}$ -16 MS straight female, 1 1/16 MS straight female
HFM-305/HFC-307: .....	1" tube, 1" VCR®, 1" VCO®, 25 mm tube, $\frac{3}{4}$ " tube, 1" Male NPT $\frac{3}{4}$ " Male NPT, 1" Female NPT, 1 5/16-12 SAE/MS Female thread
HFM-306: .....	1" tube, 1½" tube, 2" tube, 25 mm tube

## Optional 4-20 mA Current Output

An option to the standard 0 - 5 VDC output is the 4 - 20 mA current output that is proportional to flow. The 4 - 20 mA signal is produced from the 0 - 5 VDC output of the flow meter. The current loop output is useful for remote applications where pickup noise could substantially affect the stability of the voltage output.

The current loop signal replaces the voltage output on pin 6 of the “D” connector. The load must be less than 600Ω. Failure to meet this condition will cause failure of the loop transmitter.

The 4-20 mA I/O option can accept a current input. The 0-5 VDC command signal on pin 14 can be replaced by a 4-20mA command signal. The loop presets an impedance of 75 ohms and is returned to the power supply through the valve common.

## 1.3. Other Accessories

### 1.3.1. Hastings Power supplies

Hastings Power Pod power supply/display units are available in one and four channel versions. They convert 100, 115 or 230VAC to the ±15 VDC required to operate the flow meter and provide a digital indication of the flow rate. Interface terminals for the retransmission of the flow meter analog output signal are located on the rear of the panel.

The THCD-100 and Power Pod 400 models are built with controllers in mind but will work with meters as well. The Model 40 is for flow meters only. Throughout this manual, when reference is made to a power supply, it is assumed the customer is using a Hastings power supply. Hastings THCD-100 and PowerPod-400 power supplies are CE marked. The THCD-100 is not compatible with 4-20 mA analog signals. With the PowerPod 400, individual channels' input signals, as well as their commands, become 4-20 mA compatible when selected. The PowerPod-400 also sports a Totalizer feature. More information about the Power Pods can be found on the Hastings web site. <http://www.teledyne-hi.com/products/powerpod-series.htm>

### 1.3.2. Interconnecting Cables

Cables are available from Hastings, in various lengths, to connect from the 15 pin "D" connector on the back of the Power Pod directly to any of the 200 series and 300 series flow instruments (including digital versions). More information about the available cables can be found in the Power Pod 400 bulletin on the Hastings web site. <http://www.teledyne-hi.com/pdfs/bulletins.htm>

The 300 series flow instruments normally come with the standard “H” pin-out connector. This type of connector is supplied on the Hastings AF-8-AM series cables with grey backshells (such as #65-149). “U” pin-out versions of the 300 series instruments require a different cable to connect to the power supply. This cable is identifiable by black back-shells and is available as Hastings Instrument (#65-791)

## 2. Operation

This section contains the necessary steps to assist in getting a new flow meter/controller into operation as quickly and easily as possible. Please read the following thoroughly before attempting to install the instrument.

### 2.1. Receiving Inspection

Carefully unpack the Hastings 300 Series instrument and any accessories that have also been ordered. Inspect for any obvious signs of damage to the shipment. Immediately advise the carrier who delivered the shipment if any damage is suspected. Check each component shipped with the packing list. Insure that all parts are present (i.e., flow meter, power supply, cables, etc.). Optional equipment or accessories will be listed separately on the packing list. There may also be one or more OPT-options on the packing list. These normally refer to special ranges or special gas calibrations. They may also refer to special helium leak tests, or high pressure tests. In most cases, these are not separate parts, but special options or modifications built into the flow meter.

#### Quick Start

- 1. Insure flow circuit mechanical connections are leak free.**
- 2. Insure electrical connections are correct (See label).**
- 3. Power up. (Allow 30 minutes to 1 hour warm-up for best accuracy.)**
- 4. Note the flow signal decays toward zero.**
- 5. Run ~20% flow (~ 1 VDC) through instrument for 5 minutes.**
- 6. Insure zero flow; wait 2 minutes, then zero the instrument.**
- 7. Instrument is ready for operation.**

### 2.2. Power Requirements

The HFM-301/305/306 requires  $\pm 15$  VDC @ 55 mA. The HFC-303/307 requires  $\pm 15$  VDC @ 150 mA for proper operation. The supply voltage should be sufficiently regulated to no more than 50 mV ripple. The supply voltage can vary from 14.0 to 16.0 VDC. Surge suppressors are recommended to prevent power spikes reaching the instrument. The Hastings power supplies described in Section 1.3.1 satisfy these power requirements.

### 2.3. Output Signal

The standard output of the flow meter is a 0 - 5 VDC signal proportional to the flow rate. In the Hastings power supply the output is routed to the display and is also available at the terminals on the rear panel. If a Hastings supply is not used, the output is available on pin 6 of the "D" connector. It is recommended that the load resistance be no less than 2 k $\Omega$ . If the optional 4 - 20 mA output is used, the load impedance must be less than 600  $\Omega$ .

### 2.4. Mechanical Connections

The flow meter may be mounted in any position as long as the direction of gas flow through the instrument follows the arrow marked on the bottom of the flow meter case label. The preferred orientation is with the inlet and outlet fittings in a horizontal plane. If operating with a dense gas (e.g.

sulfur hexafluoride) or at high pressures (> 250 psig) the instrument must be installed horizontally. When mounted in a different orientation the instrument should be re-zeroed at zero flow with the system pressurized to the expected operating pressure.

One of the smallest of the internal passageways in the 300 Series is the diameter of the sensor tube, which can be 0.026" (0.66 mm), 0.017" (0.43mm), or 0.014" (0.36mm), so the instrument requires adequate filtering of the gas supply to prevent blockage or clogging of the tube.

The pressure regulator and the plumbing upstream must be of sufficient size to minimize changes in the upstream pressure. When switching from full flow to zero flow, the inlet pressure of instrument should rise to no more that 30% above the inlet pressure at full flow. In general, high capacity regulators and large internal diameter plumbing help to make the system more stable. The pressure drop between the regulator and the instrument due to line resistance should be minimized.

There are two threaded holes located on the bottom of the base that can be used to secure it to a mounting bracket, if desired. Other holes for special mounting can be added if desired.

The optional inlet and outlet fittings for the 301/303 are 0.5", 0.75" Swagelok, 0.5" VCR and 0.5" VCO fittings. The O-rings for the end cap are Viton (optional Kalrez, Neoprene or Buna-N). The HFM-305 and HFC-307 are provided with 1" Swagelok, VCR or VCO fittings. The HFM-306 can have 1" or 2" Swagelok fittings. It is suggested that all connections be checked for leaks after installation. This can be done by pressurizing the instrument (do not exceed pressure rating of the instrument) and applying a diluted soap solution to the flow connections.

## 2.5. Electrical Connections

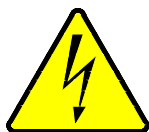

**DANGER:** Care must be taken to avoid high voltages that may be present when dealing with power supplies.

If a power supply from Hastings Instruments is used, installation consists of connecting the 300 Series cable from the "D" connector on the rear of the power supply to the "D" connector on the top of the flow meter/controller. The "H" pin-out requires cable AF-8-AM (grey molded back shell). The "U" pin-out requires cable # 65-791 (black molded back shell).

If a different power supply is used, follow the instructions below when connecting the flow meter and refer to either table 2.1 or 2.2 for the applicable pin-out. The power supply used must be bipolar and capable of providing  $\pm 15$  VDC at 55 mA for flow meter applications and  $\pm 15$  VDC at 150 mA for controllers. These voltages must be referenced to a common ground. One of the "common" pins of the Hastings instrument must be connected to the common terminal of the power supply. Case ground of the instrument should be connected to the AC ground locally. The cable shield (if available) should be connected to AC ground at the either the power supply end, or the instrument end of the cable, not at both. Pin 6 is the output signal from the flow meter. The standard output will be 0 to 5 VDC, where 5 VDC is 100% of the rated or full scale flow.

The command (set point) input should be a 0 - 5 VDC signal (or 4 - 20mA if configured as such), and must be free of spikes or other electrical noise, as these would generate false flow commands that the controller would attempt to follow. The command signal should be referenced to signal common.

A valve override command is available to the flow controller. Connect the center pin of a single pole, three-position switch (center off) to the override pin. Connect +15 VDC to one end of the three position switch, and -15 VDC to the other end. The valve will be forced full open when +15 VDC is supplied to the override pin, and full closed when -15 VDC is applied. When there is no connection to the pin (the three-position switch is centered) the valve will be in auto control, and will obey the 0 - 5 VDC commands supplied to command (set-point) input.

Figure 2-1 and Table 2-1 show the 300 Series "H" pin out.



and

show the 300 Series U” pin out.

Figure 2-1

Figure 2-2

Table 2-1 “H” Pin-out	
Pin #	
1	Do not use
2	Do not use
3	Do not use
4	Do not use
5	Signal Common
6	Output 0-5 VDC (4-20mA)

Table 2-2 “U” Pin-out	
Pin #	
1	Signal Common
2	Do not use
3	Do not use
4	+15 VDC
5	
6	Output 0-5 VDC (4-20mA)
7	Signal Common
8	Case Ground
9	Valve Override
10	
11	-15 VDC
12	External Input
13	Signal Common
14	Signal Common
15	Set Point 0-5 VDC (4-20mA)

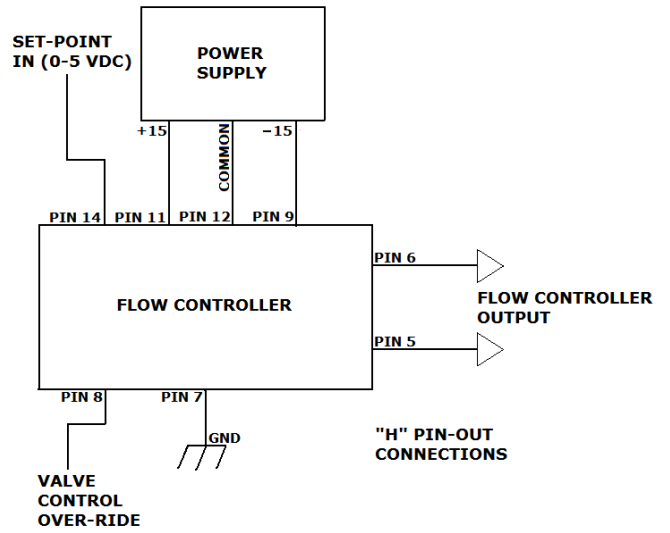
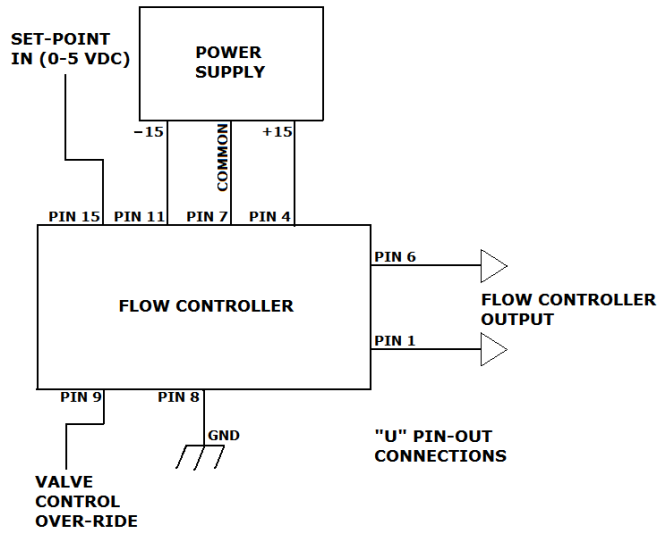

7	Case Ground
8	Valve Override
9	-15 VDC
10	Do not use
11	+15 VDC
12	Signal Common
13	External Input
14	Set Point 0-5 VDC (4-20mA)
15	Do not use

<b>Table 2-2</b>	
<b>“U” Pin-out</b>	
Pin #	
1	Signal Common
2	Do not use
3	Do not use
4	+15 VDC
5	
6	Output 0-5 VDC (4-20mA)
7	Signal Common
8	Case Ground
9	Valve Override
10	
11	-15 VDC
12	External Input
13	Signal Common
14	Signal Common
15	Set Point 0-5 VDC (4-20mA)

## 2.6. 4 – 20 mA Connections

The 300 Series flow meters have a 4 - 20 mA current output option available as an alternative to the standard 0 - 5 VDC output. This current output is useful for remote applications where noise pick-up could substantially affect the stability of the voltage output. The 4 - 20 mA signal is produced from the 0 - 5 VDC output of the flow meter and replaces the voltage output on pin 6 of the “D” connector. The current is sourced by the flow controller and the metering circuit must sink the current, such that the current loop is completed through power supply common connections. The load must be less than 600 Ohms. Failure to meet this condition will cause failure of the loop transmitter.

The 300 Series flow controllers have a 4 - 20 mA current input option available as an alternative to the standard 0 - 5 VDC command input. The controller sinks the input current through a 77 Ohm load to power supply common.

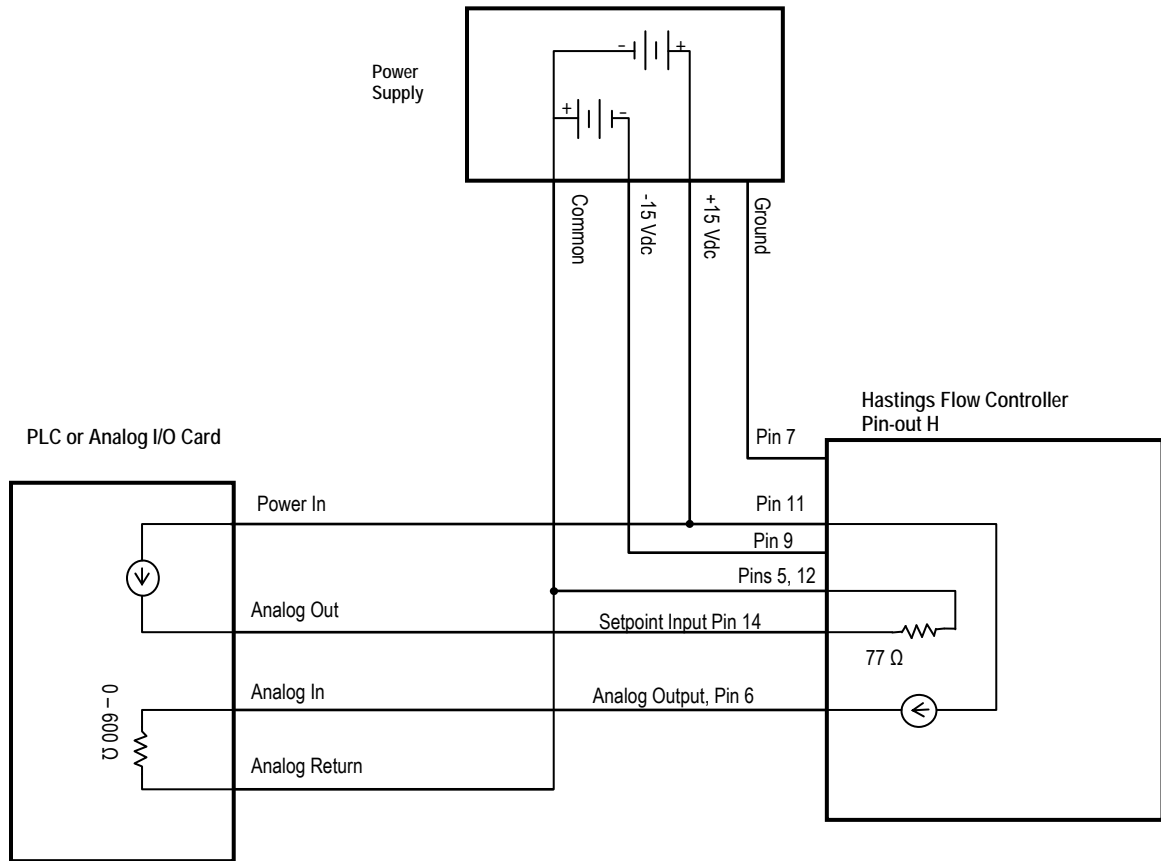

Figure 2-3

## 2.7. Operation

The standard instrument output is a 0 - 5 VDC and the signal is proportional to the flow i.e., 0 volts = zero flow and 5 volts = 100% of rated flow. The 4 - 20 mA option is also proportional to flow, 4 mA = zero flow and 20 mA = 100% of rated flow.

### 2.7.1. Operating Conditions

For proper operation, the combination of ambient temperature and gas temperature must be such that the flow meter temperature remains between -20 and 70°C. Most accurate measurement of flow will be obtained if the flow meter is zeroed at operating temperature as temperature shifts result in some zero offset. The 300 Series is intended for use in non-condensing environments only. Condensate or any other liquids which enter the flow meter may destroy its electronic components.

### 2.7.2. Zero Check

Turn the power supply on if not already energized. Allow for a 1 hour warm-up. Stop all flow through the instrument and wait 2 minutes. Caution: Do not assume that all metering valves completely shut off the flow. Even a slight leakage will cause an indication on the meter and an apparent zero shift. Adjust the zero potentiometer located on the lower inlet side of the flow meter until the meter indicates zero flow. This zero should be checked periodically during normal operation. Zero adjustment is required if there is a change in ambient temperature, or vertical orientation of the flow meter /controller.

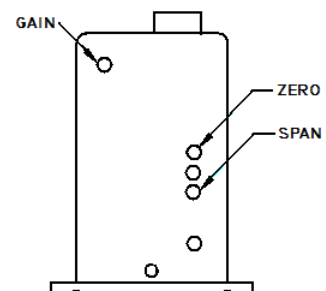

### 2.7.1. High Pressure Operation

Thermal mass flow meters measure the heat transfer caused by gas flow. This heat transfer is a function of the constant pressure specific heat ( $C_p$ ) of the gas. For monatomic gases the specific heat is

essentially a constant for all normal pressure/temperature conditions. As the gas structure becomes more complex and as the molecular weight of the gas increases the specific heat increases as the pressure inside of the sensing tube increases. This is compensated somewhat by the effect of the hoop strain of the tube wall caused by the internal pressure on the resistance heaters wrapped around the sensing tube.

Larger tubing will have more strain than the smaller tubing and a larger associated pressure affect. Charts of the effects of various gases on the span of the flow instruments as a function of pressure are shown below for each of the available sensor diameters. The sensor tubing diameter is written on a label mounted on the side of the sensor and is listed in the options in the order acknowledgement.

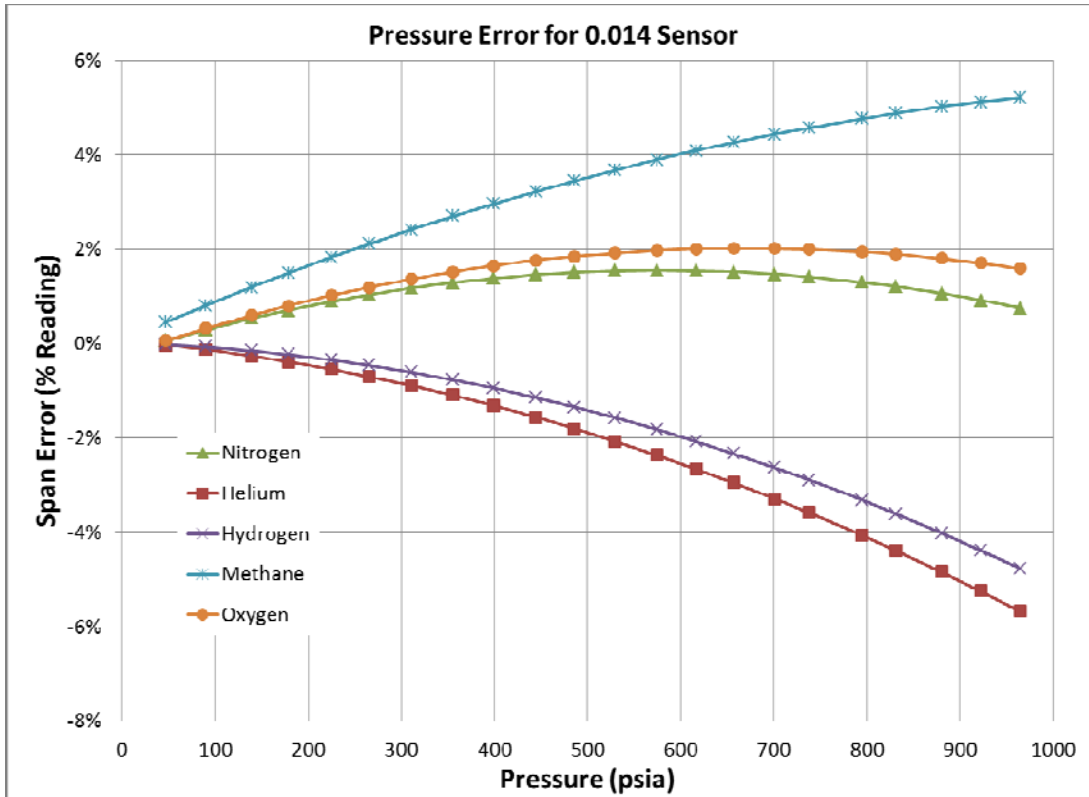
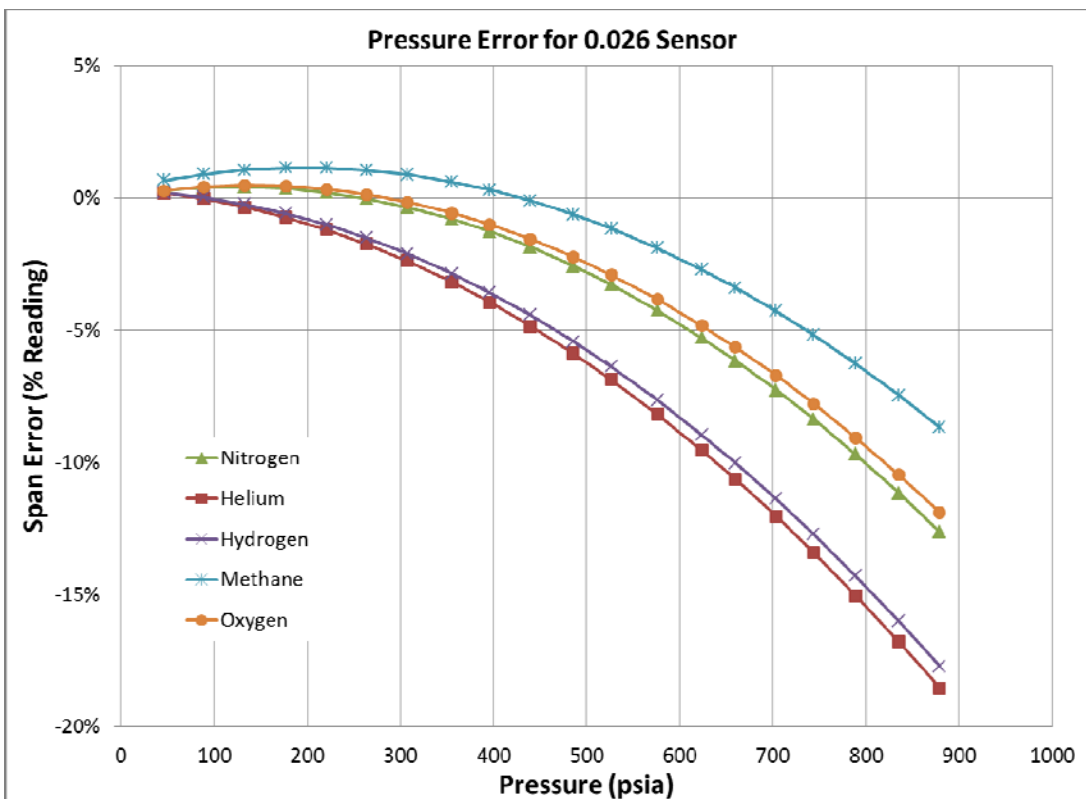
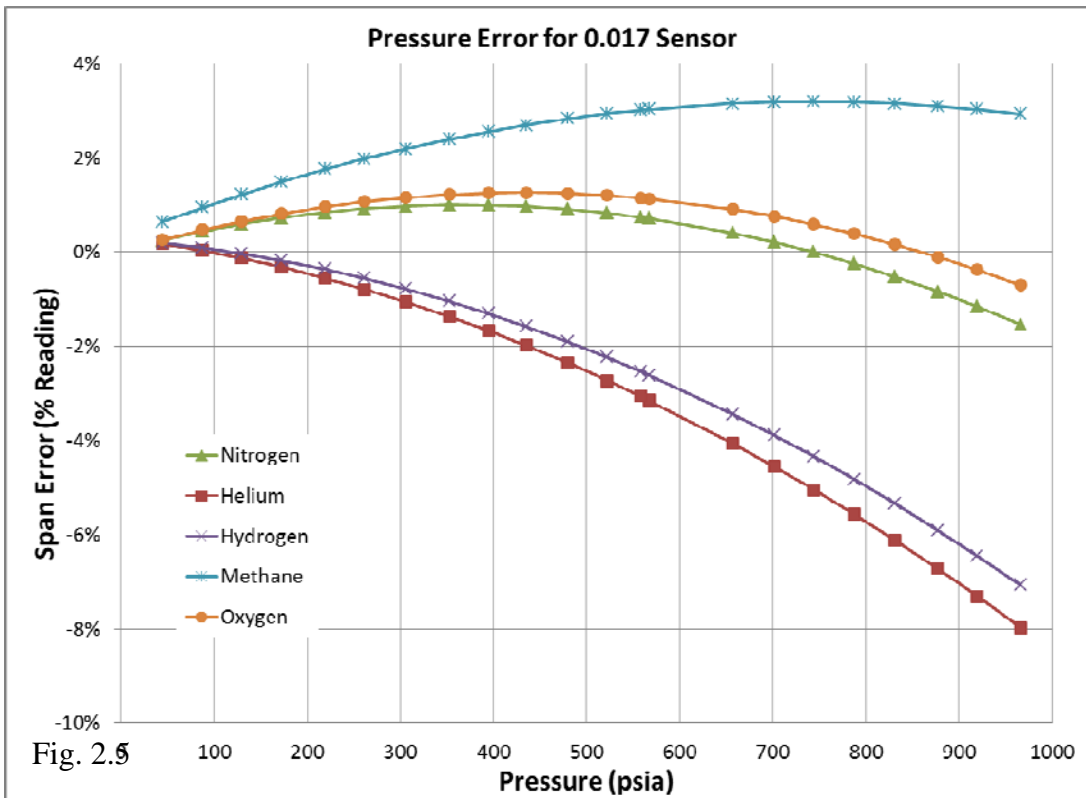

Fig. 2.4



If the system pressure is higher than 250 psig (1.7 MPa) the pressure induced error in the span reading becomes significant. This error will approach 16% for nitrogen at 1000 psig. For accurate high pressure measurements this error must be corrected.

The formula for predicting the nitrogen mean error expressed as a fraction of the reading are:

$$Error_{26} = (-2.2915 * 10^{-7})P^2 + (5.7198 * 10^{-5})P, \quad (0.026" \text{ Sensor})$$

$$Error_{17} = (-7.1066 * 10^{-8})P^2 + (5.2403 * 10^{-5})P, \quad (0.017" \text{ Sensor})$$

$$Error_{14} = (-5.3091 * 10^{-8})P^2 + (6.1278 * 10^{-5})P, \quad (0.014" \text{ Sensor})$$

Where P is the pressure in psig and *Error* is the fraction of the reading in error.

The flow reading can be corrected as follows:

$$Corrected = Indication - (Indication * Error)$$

Where the *Indication* is the indicated flow and *Error* is the result of the previous formula (or read from charts above).

### 2.7.2. Vertical Mounting

When operating at high pressure or with high density gases, the increased density of gas will cause natural convection to flow through the sensor tube, if the instrument is not mounted in a level position. This natural convection flow will be proportional to the square of the gas density and therefore to system pressure. This will be seen as a shift in the zero flow output that changes as the system pressure changes. Heavier gases will have more of an effect than light gases.

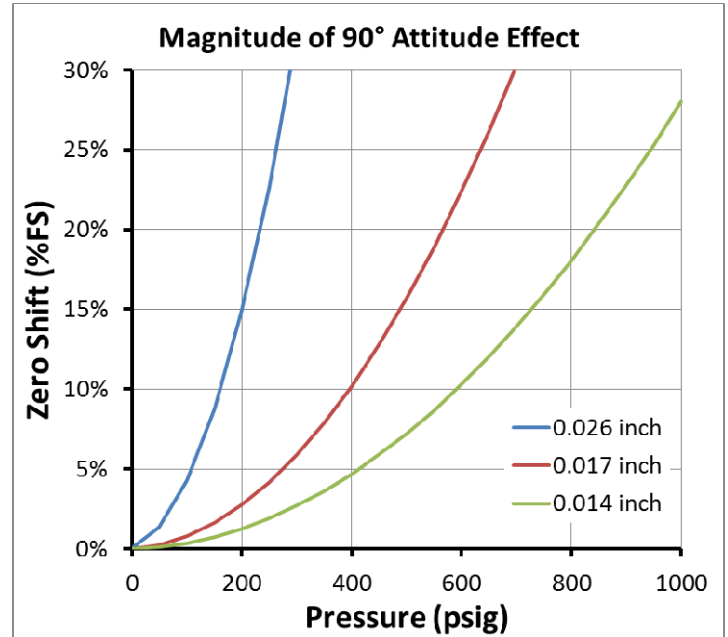

If the instrument is measuring light gases or low pressure, the change in the zero due to natural convection will be minimal. Larger shifts could be zeroed out with the zero pot as long as the upstream pressure is stable. It is not recommended to mount the instrument vertically if high pressure or high density gas is being measured. A chart is shown here for nitrogen/air versus pressure.

If the error exceeds 20-30% (of full scale), the zero circuit installed in the instruments, may no longer be able to be adjusted to compensate for the error.



**CAUTION:** The HFM-306 does not have a high pressure option and is only rated for a maximum working pressure of 300 psig.

### 2.7.3. Blending of Gases

In the blending of two gases, it is possible to maintain a fixed ratio of one gas to another. In this case, the output of one flow controller is used as the reference voltage for the set point potentiometer of a second flow controller. The set point potentiometer then provides a control signal that is proportional to the output signal of the first flow controller, and hence controls the flow rate of the second gas as a percentage of the flow rate of the first gas.

**EXAMPLE:** Flow controller A has 0 - 100 slm range with a 5.00 volt output at full scale. Flow controller B has 0 - 10 slm range with a 5.00 volt output at full scale. If flow controller A is set at 80 slm, its output voltage would be 4.00 volts (80 slm/100 slm x 5.00 volts = 4.00 volts). If the output signal from flow controller A is connected to the command potentiometer of flow controller B, it then becomes a variable reference voltage for flow controller B proportional to the flow rate of flow controller A.

If the set point potentiometer of flow controller B is set at 50% of full scale, and the reference voltage from flow controller A is 4.00, then the command signal going to flow controller B would be 2.00 volts (4.00 volts x 50.0% = 2.00 volts). The flow of gas through flow controller B is then controlled at 4 slm (2.00 volts/5.00 volts x 10 slm = 4 slm).

The ratio of the two gases is 20:1 (80 slm/4slm). The % mixture of gas A is 95.2 (80slm/84slm) and the % mixture of gas B is 4.8% (4 slm/84 slm).

Should the flow of flow controller A drop to 78 slm, flow controller B would drop to 3.9 slm, hence maintaining the same ratio of the mixture. (78 slm/100slm x 5v = 3.90v x 50% = 1.95v; 1.95v/5.00v x 10 slm = 3.9 slm; 78 slm: 3.9 slm = 20:1)

## 2.8. Range Changing

Changing the range of a flow controller can be done in the field, but calibration is required. It is recommended however, that the unit be sent back to the factory along with the new range desired, gas and operating parameters. Consult factory for more information.

## 2.9. Output Filter

The flow output signal may have noise superimposed on the mean voltage levels. This noise may be due to high turbulence in the flow stream that the fast sensor is measuring or it could be electrical noise when the flow meter has a high internal gain (i.e. 5 sccm full scale meter). Varying levels of radio frequency noise or varying airflow over the electronics cover can also induce noise.

Noise can be most pronounced when measuring the flow output with a sampling analog/digital (A/D) converter. When possible, program the system to take multiple samples and average the readings to determine the flow rate.

If less overall system noise is desired, a jumper may be installed over the pins of JP1 on the flow measurement card. See Figure 2-4. Covering the two top most pins (1 & 2), that are closest to the span adjustment potentiometer (R8), will activate a resistor-capacitor (RC) filter that has a time constant of one second. This will increase the settling time of the indicated flow rate to approximately 4 seconds. Covering the bottom most pins (2 & 3), will lower the response time to approx. 1 second.

This adjustment will not affect the calibration of the flow meter circuit or the actual flow response to change in command signal (flow controllers). This will only slow down the indicated response (output voltage/current).

## 2.10. Controlling Other Process Variables

Normally, a flow controller is setup to control the mass flow. The control loop will open and close the valve as necessary to make the output from the flow measurement match the input on the command line. Occasionally, gas is being added or removed from a system to control some other process variable. This could be the system pressure, oxygen concentration, vacuum level or any other parameter which is important to the process. If this process variable has a sensor that can supply an analog output signal proportional to its value then the flow controller may be able to control this variable directly. This analog output signal could be 0 - 5 Volts, 0 - 10 Volts (or 4 - 20 mA for units with 4 - 20 mA boards) or any value in between.

On the CONTROLLER card there is a jumper (JP-1) that sets whether the control loop controls mass flow or an external process variable. See Figure 2-5. If the jumper connects the top two pins, the loop controls mass flow. If the jumper connects the bottom two pins, the loop controls an external process variable. This process variable signal must be supplied on pin 13 of the D-connector (for H pin out units) or pin 12 of the D-connector (for U pin out units) of the measurement card. When the controller is set for external variable control it will open or close the valve as necessary to make the external process variable signal match the command signal. The command signal may be 0 - 5 Volts, 0 - 10 Volts (4 - 20 mA for 4 - 20 mA input/output cards) or any value in between. If the process variable has a response

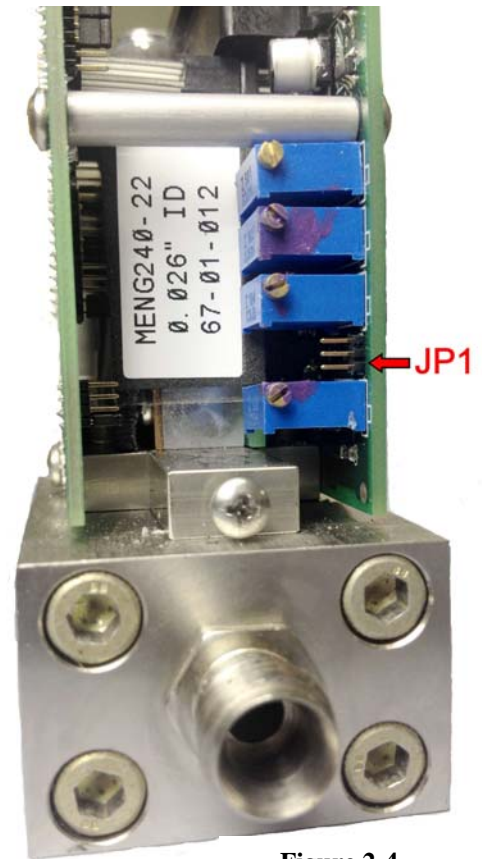

Figure 2-4

time that is much faster or slower than the flow meter signal it may be necessary to adjust the gain potentiometer.

## 2.11. Command Input

The flow controller will operate normally with any command input signal between 0 - 10 Volts (4 - 20 mA for units with 4 - 20 mA input/output cards). If the command signal exceeds  $\pm 14$  volts it may damage the circuit cards. During normal operation the control loop will open or close the valve to bring the output of the flow meter signal to within  $\pm 0.001$  Volts of the command signal. The command signal will not match the flow signal if there is insufficient gas pressure to generate the desired flow. If the command signal exceeds 5 Volts the controller will continue to increase the flow until the output matches the command signal. However, the flow output may not maintain the published accuracy values under these conditions.

If the command signal is less than 1% of full scale (0.05 Volts or 4.16 mA) the valve override control circuit will activate in the closed position. This will force the valve completely closed regardless of the flow signal.

## 2.12. Valve Override Control

The valve override control line provides a method to override the loop controller and open or close the valve regardless of the flow or command signals. During normal operation this line must be allowed to float freely. This will allow the loop control to open and close the valve as it requires. If the valve override line is forced high ( $> +5$  Volts) the valve will be forced full open. If the valve overrides line is forced negative ( $< -5$  Volts) the valve will be forced closed.

## 2.13. Gain Potentiometer

On the top left of the inlet side of the flow controller there is a hole through which the gain potentiometer is accessible. See Figure 2-5 and Figure 3-2. This gain potentiometer affects the gain of the closed loop controller. Normally this potentiometer will be set at the factory for good stable control. It may be necessary to adjust this potentiometer in the field if the system varies widely from the conditions under which the controller was setup. Turning this gain potentiometer clockwise will improve stability. Turning the potentiometer counter-clockwise will speed up the valve reaction time to changes in the command signal

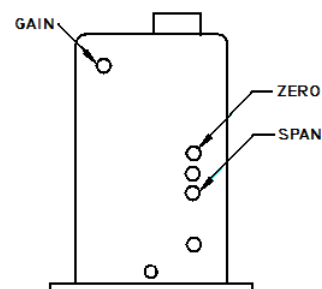

## 2.14. Temperature Coefficients

As the temperature of the instrument changes from the calibration temperature, errors will be introduced into the output of the instrument. The Temperature Coefficient of Zero describes the change in the output that is seen at zero flow. This error is added in to the overall output signal regardless of flow, but can be eliminated by adjusting the zero potentiometer to read zero volts at zero flow conditions. The Temperature Coefficient of Span describes the change in output after the zero error is eliminated. This error cannot be eliminated, but can be compensated mathematically if necessary. The curve pictured in Error! Reference source not found. shows the span error in percent of point as a function of temperature assuming 23 °C is the calibration temperature.

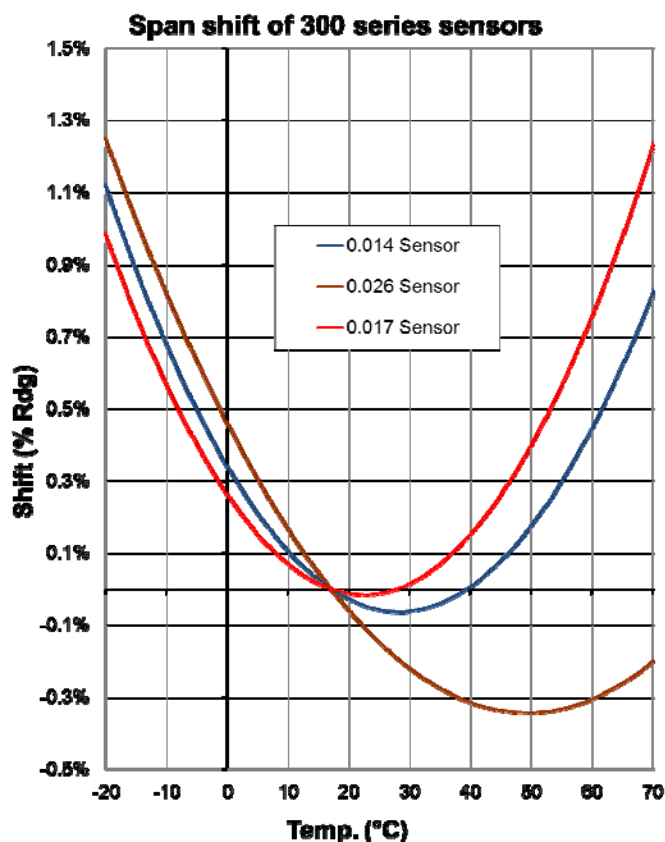



# 3. Maintenance

## 3.1. Authorized Maintenance

With proper care in installation and use, the flow meter will require little or no maintenance. If maintenance does become necessary, most of the instrument can be cleaned or repaired in the field. Some procedures may require recalibration. Do not attempt these procedures unless facilities are available. Entry into the sensor or tampering with the printed circuit board will void warranty. Do not perform repairs on these assemblies while the unit is still under warranty.



**CAUTION:** Some parts of the instrument are delicate and other parts are heavy enough to cause an injury if dropped. Use extreme care when servicing the instrument. The potentiometer positions and the electrical components referred to in the troubleshooting section can be found in Section 3.3.

## 3.2. Troubleshooting

**Symptom:** Output reads strong indication of flow with no flow present. Zero pot has no effect.

**Cause:** Power shorted out.

**Action:** Turn the power supply off for a few seconds then turn it on again. If this is ineffective, disconnect the power supply from the unit. Check that the power supply voltages are correct. Incorrect voltages most likely signify a faulty regulator chip inside the supply. If the power supply display returns to zero after the instrument has been disconnected there may be a short from the unit to ground.

**Symptom:** 300 Series instrument output continues to indicate flow with no flow present, or indicates  $\pm 14$  volts. Power supply inputs are correct (see the above troubleshooting tip) and zero pot has no effect.

**Cause:** Faulty IC chip(s) on the main PC board.

**Action:** Replace main PC board. (See Section 3.5)

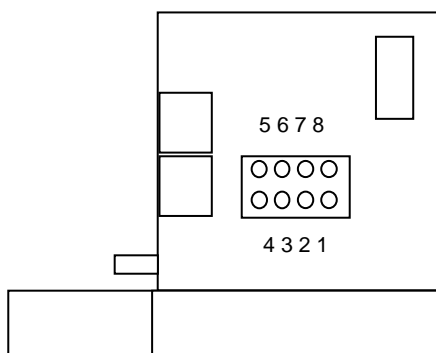

**Figure 3-1**

**Symptom:** Output of flow meter is proportional to flow, but extremely small and not correctable by span pot.

**Cause:** Sensor is not being heated.

**Action:** Shut off gas supply and disconnect the power to the flow meter. Remove cover and PC board from unit. Check the resistance from pins 1 to 2 and 3 to 4 of the sensor module. Both sets of pins should read approximately the same value between 1 and 2 k $\Omega$  nominal resistance. Also check that the resistance from pins 5 to 6, and 7 to 8 are both nearly the same value between 200 and 400  $\Omega$ . See Figure 3-1. Incorrect resistance values indicate that the sensor unit needs to be replaced.

**Symptom:** Sensor has proper resistance readings, but little or no output with flow.

Cause:	Plugged sensor.
Action:	Shut off gas supply and disconnect the power to the flow meter. Remove cover and PC board from unit. Remove and inspect sensor. If sensor has evidence of clogging, clean or replace as applicable.
Symptom:	Flow meter reads other than 0.00 VDC with no flow or there is a small flow when the flow meter reads 0.00 VDC.
Cause:	Zero pot is out of adjustment.
Action:	Shut off all flow. For the standard 0 - 5 VDC output, adjust the zero potentiometer (see Section 3.3) located on the upper right inlet side of the flow meter until the meter indicates zero. For the optional 4 - 20 mA output, adjust the zero potentiometer so that the meter indicates slightly more than 4 mA, i.e. 4.03 to 4.05 mA. This slight positive adjustment ensures that the 4 - 20 mA transmitter is not in its cut-off region. The error induced by this adjustment is approximately 0.3% of full scale.
Symptom:	Flow meter is out of calibration and non-linear.
Cause:	Leaks in the gas inlet or outlet fittings.
Action:	Check all fittings for leaks by placing soap solution on all fittings between gas supply and final destination of gas. Check flow meter for leaks. Replace if required or recalibrate as necessary.
Symptom:	Little or no flow, even when the valve is in override OPEN.
Cause:	Blocked orifice or incorrect pressure across the flow controller
Action:	Verify that there is 10 to 15 psig pressure across the instrument. If the differential pressure across the instrument is correct, the orifice may be obstructed. Remove all gas pressure and shut off power supply. Remove the valve.

### 3.3. Adjustments

1. Connect power to "D" connector as specified in Section 2.5. Allow the instrument to warm up for at least 30 minutes (60 minutes for best accuracy). Note the flow signal decays toward zero. Run ~20% of flow range (~1 VDC) through instrument for 5 minutes.
2. Completely shut off the flow and wait for 2 minutes. Adjust the zero potentiometer located on the lower inlet side of the flow meter (see Figure 3-2) until the meter indicates zero.
3. Turn on gas supply to inlet of instrument and adjust the flow rate to the desired full scale flow as indicated by a reference flow meter/controller. If the instrument to be calibrated is a controller, adjust the flow rate by setting the command to 100% of full scale.
4. Perform this step only if a calibrated reference flow meter is available. Adjust Span pot (see Figure 3-2) until the indicated flow reads full scale (5.00 VDC or 20 mA) and the reference meter/controller reads the desired full scale flow rate.
5. Record flow meter/controller and flow reference outputs for flow rates of 20%, 40%, 60%, 80% and 100% and make sure data are within  $\pm 1\%$  of full scale.

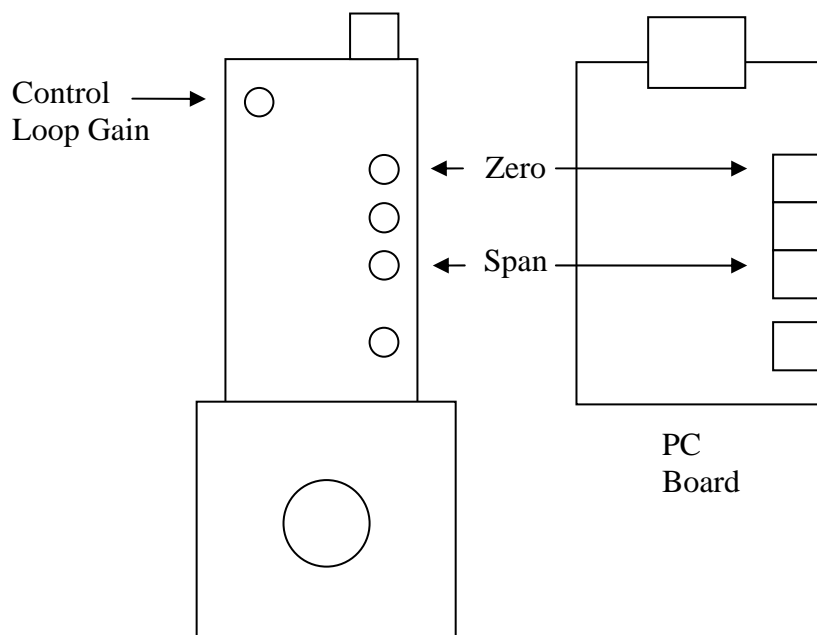

Figure 3-2

### 3.4. End Cap Removal

The end cap on the inlet side must be removed to gain access to shunt assembly. First remove power and shut off the supply of gas to the instrument. Disconnect the fittings on the inlet and outlet sides of the transducer and remove it from the system plumbing. On both the HFM-301 and HFC-303, remove the four Allen head screws holding the end cap to the instrument. Carefully remove the “O”-ring sealed end cap and shunt, noting their order and the proper annular orientation of the shunt. The shunt position is critical to the flow dynamics and can substantially affect the instrument linearity. The shunt can be severely damaged if dropped. Examine the shunt. If damaged, dirty or blocked, clean and replace as applicable. Reassemble in the reverse order of disassembly. Secure the endcap with 65 in lb. (7.3 N.m) to 85 in lb (9.6 N.m) of torque on each high-tensile socket head cap screw. Use of a fastener other than the one mentioned here may result in leakage at the seal. Recalibration of the 301/303 series instrument is necessary.

For the HFM-305/307 remove the four 12 point bolts securing the endcap while carefully holding the endcap in place. Carefully remove the metal gasket sealed endcap and shunt, noting their order and the proper annular orientation of the shunt. The shunt position is critical to the flow dynamics and can substantially affect the instrument linearity. The shunt can be severely damaged if dropped. Examine the shunt. If damaged, dirty or blocked, clean and replace as applicable. Reassemble in the reverse order of disassembly replacing the used metal gasket with a new one. Secure the endcap with 35 ft lb. (47.5 N.m) to 40 ft lb. (54.3 N.m) of torque on each 12 pt bolt. Use of a fastener other than the one mentioned here may result in leakage at the seal. Recalibration of the 305/307 series instrument is necessary.

For the HFM-306, remove the six hex socket bolts from the inlet end cap. Remove the end cap and ensure that the o-ring is not damaged. Remove the flow conditioning screen assembly and if damaged, dirty or blocked, clean and replace as applicable. Carefully remove the flow straightener and shunt assembly. If damaged, dirty or blocked, clean and replace as applicable. Reassemble in the reverse order of disassembly. Recalibration of the HFM-306 instrument is necessary.

### 3.5. Printed Circuit Board and Sensor Replacement

**NOTE:** This instrument contains static sensitive PC boards. Maintain static protection when handling the PC boards.

In the event that any of the PC boards fail, they are easily removed from the instrument and replaced with a spare. It is recommended that the metering printed circuit board and sensor be replaced as a unit

because they are electronically matched to optimize response time. The sensor can also be removed easily. This ease in disassembly and replacement substantially reduces instrument downtime.

1. Replacement of the 4 - 20 mA option PC board: Unplug the power cable from the instruments "D" connector. Remove the fasteners and steel can. The 4-20 mA board is the PC board marked PC854 in the lower left-hand corner just above the Teledyne logo. Remove the screws and lift off the 4 - 20 mA board. Be careful not to damage the main board and 4 - 20 mA board connector.

2. Replacement of the main PC board: Unplug the power cable from the instruments "D" connector. Remove the fasteners and steel can. Remove the 4 screws which fasten the main PC board to the sensor module. Gently unplug the main board from the sensor (and from the 4 - 20 mA board, if present).

3. Replacement of the flow sensor: Remove the PC board(s) as described above. Remove the four (4) Allen head cap screws that fasten the sensor to the main instrument base. Remove the sensor module from the base, discarding the used nickel gaskets. New nickel gaskets are required for re-assembly.

To place an order or to obtain information concerning replacement parts, contact the factory representative in your area. See section 4 in this manual for the address or phone number. When ordering, include the following information: Instrument model number, part description and Hastings part number.

# 4. WARRANTY

## 4.1. Warranty Repair Policy

Hastings Instruments warrants this product for a period of one year from the date of shipment to be free from defects in material and workmanship. This warranty does not apply to defects or failures resulting from unauthorized modification, misuse or mishandling of the product. This warranty does not apply to batteries or other expendable parts, or to damage caused by leaking batteries or any similar occurrence. This warranty does not apply to any instrument which has had a tamper seal removed or broken.

This warranty is in lieu of all other warranties, expressed or implied, including any implied warranty as to fitness for a particular use. Hastings Instruments shall not be liable for any indirect or consequential damages.

Hastings Instruments, will, at its option, repair, replace or refund the selling price of the product if Hastings Instruments determines, in good faith, that it is defective in materials or workmanship during the warranty period. Defective instruments should be returned to Hastings Instruments, shipment prepaid, together with a written statement of the problem and a Return Material Authorization (RMA) number.

Please consult the factory for your RMA number before returning any product for repair. Collect freight will not be accepted.

## 4.2. Non-Warranty Repair Policy

Any product returned for a non-warranty repair must be accompanied by a purchase order, RMA form and a written description of the problem with the instrument. If the repair cost is higher, you will be contacted for authorization before we proceed with any repairs. If you then choose not to have the product repaired, a minimum will be charged to cover the processing and inspection. Please consult the factory for your RMA number before returning any product repair.

TELEDYNE HASTINGS INSTRUMENTS  
804 NEWCOMBE AVENUE  
HAMPTON, VIRGINIA 23669 U.S.A.  
ATTENTION: REPAIR DEPARTMENT

TELEPHONE	(757) 723-6531
TOLL FREE	1-800-950-2468
FAX	(757) 723-3925
E MAIL	hastings_instruments@teledyne.com
INTERNET ADDRESS	<a href="http://www.teledyne-hi.com">http://www.teledyne-hi.com</a>

Repair Forms may be obtained from the "Information Request" section of the Hastings Instruments web site.

# 5. Appendix

## 5.1. Appendix 1- Volumetric versus Mass Flow

Mass flow measures just what it says, the mass or number of molecules of the gas flowing through the instrument. Mass flow (or weight per unit time) units are given in pounds per hour (lb/hour), kilograms per sec (kg/sec) etc. When your specifications state units of flow to be in mass units, there is no reason to reference a temperature or pressure. Mass does not change based on temperature or pressure.

However, if you need to see your results of gas flow in volumetric units, like liters per minute, cubic feet per hour, etc. you must consider the fact that volume DOES change with temperature and pressure. To do this, the density (grams/liter) of the gas must be known and this value changes with temperature and pressure.

When you heat a gas, the molecules have more energy and they move around faster, so when they bounce off each other, they become more spread out, therefore the volume is different for the same number of molecules.

Think about this:

The density of Air at 0°C is 1.29 g/liter

The density of Air at 25°C is 1.19 g/liter

The difference is 0.1 g/liter. If you are measuring flows of 100 liters per minute, and you don't use the correct density factor then you will have an error of 10 g/minute!

Volume also changes with pressure. Think about a helium balloon with a volume of 1 liter. If you could scuba dive with this balloon and the pressure on it increases. What do you think happens to the weight of the helium? It stays the same. What would happen to the volume (1 liter)? It would shrink.

Why is the word standard included with the volume terms liters and cubic feet in mass flow applications?

A mass flow meter measures mass ...and we know we can convert to volume.

To use density we must pick one (or standard) temperature and pressure to use in our calculation. When this calculation is done, the units are called standard liters per minute (SLM) or standard cubic feet per minute (SCFM), for instance, because they are referenced to a standard temperature and pressure when the volume is calculated.

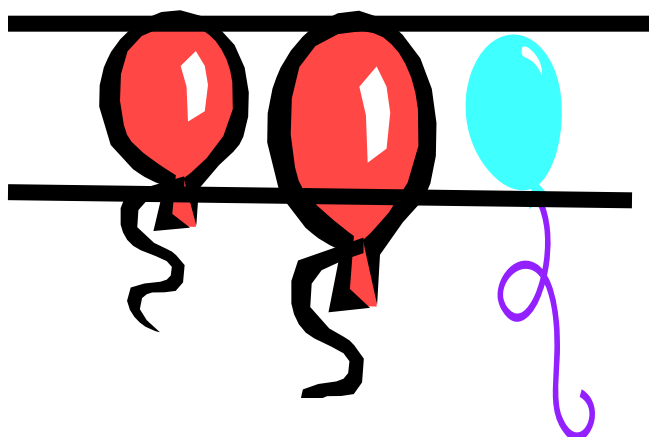

1 Liter	1.08 Liter	1 Liter
0 °C	25 °C	25 °C
0.179 grams/1 liter	0.179 g/1.08 liters	0.164 grams

Using the example to the left, we can see a standard liter can be defined differently. The first balloon contains 0.179 grams of Helium at 0 °C and 760 Torr (density of 0.179 grams/liter). Heat up that balloon to room temperature and the volume increases, but the mass has not changed. The volume is not 1 liter anymore, it is 1.08 liters.

So, to define a standard liter of Helium at 25 °C, we must extract only one liter from the second balloon and that liter weighs only 0.175 grams.

If a mass flow meter is set up for STP at 0 °C and 760 Torr, when it measures 0.179 grams of He, it will give you results of 1 SLM. If a second meter is set up for STP at 25 °C and 760 Torr, when it measures 0.164 grams, it will give results of 1 SLM.

## 5.2. Appendix 2 - Gas Conversion Factors

Gas conversion factors (GCF's) for gasses metered using Hastings Instruments products, can be found by visiting the Hastings Instruments web site. The web address can be found at the end of this document. The gas conversion factors (GCF's) provided by Hastings Instruments (HI) fall into five basic accuracy domains that, to a large extent, are dependent on the method by which they are found. The following table summarizes the different methods used to determine the GCF's. The table lists the methods in decreasing order of the degree of accuracy that may be achieved when applying a conversion factor.

### Methods Used to Determine Gas Conversion Factors

1. Determined empirically at Hastings Instruments
  2. Calculated From NIST tables
  3. Calculated using the virial coefficients of independent investigators' empirical data using both temperature and pressure as variables.
  4. Calculated from virial coefficients using temperature only.
  5. Calculated from specific heat data at 0° C and 1 atmosphere
1. The most accurate method is by direct measurement. Gases that can be handled safely, inert gases, gases common in the atmosphere, etc., can be run through a standard flow meter and the GCF determined empirically.
  2. The National Institute of Standards and Technology (NIST) maintains tables of thermodynamic properties of certain fluids. Using these tables, one may look up the necessary thermophysical property and calculate the GCF with the same degree of accuracy as going directly to the referenced investigator.
  - 3 & 4. Many gases that have been investigated sufficiently by other researchers, can have their molar specific heat (C<sub>p</sub>) calculated. The gas conversion factor is then calculated using the following ratio.

$$GCF = \frac{C'_{pN_2}}{C'_{pGasX}}$$

GCF's calculated in this manner have been found to agree with the empirically determined GCF's within a few tenths of a percent. Data from investigations that factor in pressure as well as temperature, usually supply a higher degree of accuracy in their predictions.

5. For rare, expensive gases or gases requiring special handling due to safety concerns, one may look up specific heat properties in a variety of texts on the subject. Usually, data found in this manner applies only in the ideal gas case. This method yields GCF's for ideal gases but as the complexity of the gas increases, its behavior departs from that of an ideal gas. Hence the inaccuracy of the GCF increases.

Hastings Instruments continually searches for better estimates of the GCF's of the more complex gases and regularly updates the list.

Most Hastings flow meters and controllers are calibrated using nitrogen. The conversion factors published by Hastings are meant to be applied to these meters. To apply the GCF's, simply multiply the gas flow reading and the GCF for the process gas in use. For example, to calculate the actual flow of argon passing through a nitrogen-calibrated meter that reads 20 sccm, multiply the reading and the GCF for argon.

$$20 \times 1.4047 = 28.094$$

Conversely, to determine what reading to set a nitrogen-calibrated meter in order to get a desired flow rate of a process gas other than nitrogen, you divide the desired rate by the GCF. For example, to get a desired flow of 20 sccm of argon flowing through the meter, divide 20 sccm by 1.4047.

$$20 / 1.4047 = 14.238$$

That is, you set the meter to read 14.238 sccm.

Some meters, specifically the high flow meters, are calibrated in air. The flow readings must be corrected for the case where a gas other than air is flowing through the meter. In addition, there must be a correction for the difference in the GCF from nitrogen to air. In this case, multiply the reading and the ratio of the process gas' GCF to the GCF of the calibration gas. For example, a meter calibrated in air is being used to measure the flow of propane. The reading from the meter is multiplied by the GCF for propane divided by the GCF of air.

$$20 * (0.3499/1.0015) = 6.9875$$

To calculate a target setting (20 sccm) to achieve a desired flow rate of propane using a meter calibrated to air, invert the ratio above and multiply.

$$20 * (1.0015/0.3499) = 57.2449$$

Gas conversion factors can be found at the Hastings Instruments web site.

<http://www.teledyne-hi.com>

Follow the link to Mass Flow Products and then to Gas Conversion Factors.