

Operating Instructions

UNO 005 A
UNO/DUO 2.5 A
UNO/DUO 2.5 AC

Rotary Vane Vacuum Pumps

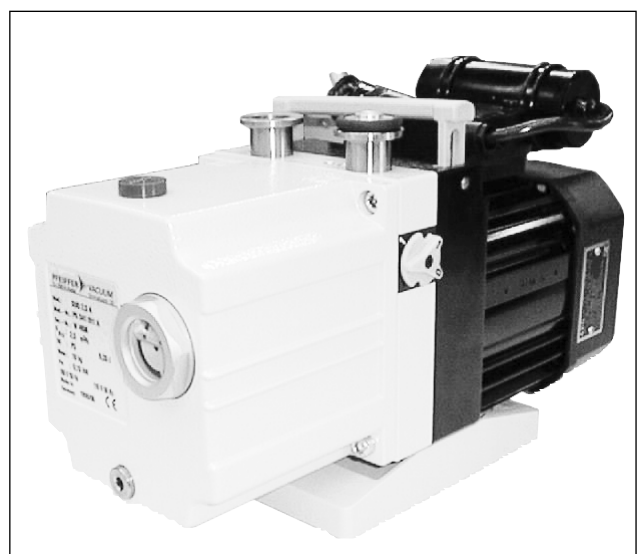
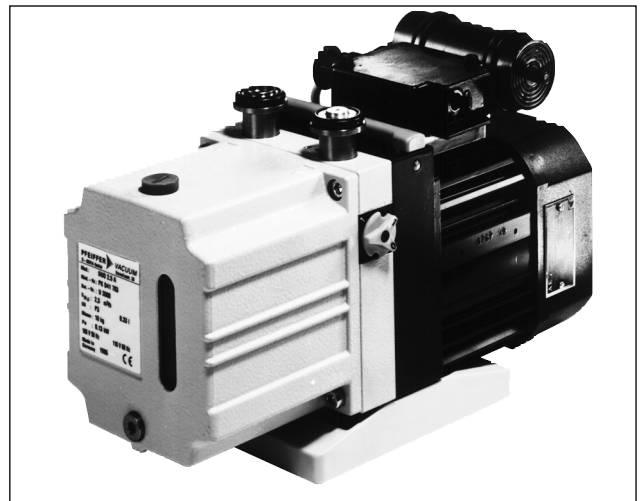

INDEX

	Page		Page
1. Safety Precautions	2	4.5. Gas Ballast Valve (For Corrosive Gas Processes).....	7
1.1. For Your Orientation.....	2	4.6. Silencer.....	7
2. Understanding The Pump	3	5. What To Do In Case Of Breakdowns? ...	8
2.1. Main Features.....	3	6. Maintenance	8
2.2. Design	3	6.1. Replacing The Operating Fluid.....	8
3. Installation	3	6.2. Shutting Down For Longer Periods	9
3.1. Preparations For Installation.....	3	7. Service	9
3.2. Pump Set-Up And Location	3	8. Technical Data	10
3.3. Connecting The Vacuum Side.....	4	8.1. Dimensions.....	11
3.4. Connecting The Exhaust Side	4	9. Accessories	11
3.5. Connecting To The Mains Power Supply.....	5	10. Spare Parts	12
4. Operations	6	Declaration Of Contamination	13
4.1. Filling Up And Checking The Operating Fluid	6	Conformity Declaration	(last page)
4.2. Switching The Pump ON And OFF.....	6		
4.3. Pumping Dry Gases And Vapours	6		
4.4. Gas Ballast Valve (Standard Version)	7		

1. Safety Precautions

- ☞ Read and follow all the instructions in this manual.
- ☞ Inform yourself regarding:
 - Hazards which can be caused by the pump;
 - Hazards which can arise in your system;
 - Hazards which can be caused by the medium being pumped.
- ☞ Avoid exposing any part of your body to vacuum.
- ☞ Observe all safety and accident prevention regulations.
- ☞ Check regularly that all safety requirements are being complied with.
- ☞ Do not use the pump for the purpose of generating pressure.
- ☞ Do not carry out any unauthorised conversions or modifications on the pump.
- ☞ When returning the pump to us please note the shipping instructions in the section on 7. service.

1.1. For Your Orientation

Operating instruction in the text:

- ➔ Here, you have to do something.

Symbols used

The following symbols are used throughout in the illustrations:

- | | |
|---|--|
|  Vacuum flange |  Exhaust flange |
|  Gas ballast valve |  Power connection |

Position numbers

Identical pump and accessory parts have the same position numbers in all illustrations.

Pictogram definitions



Danger of burns from touching hot parts.



Danger of personal injury.



Danger of damage to the pump or system.

Modifications reserved

2. Understanding The Pump

2.1. Main Features

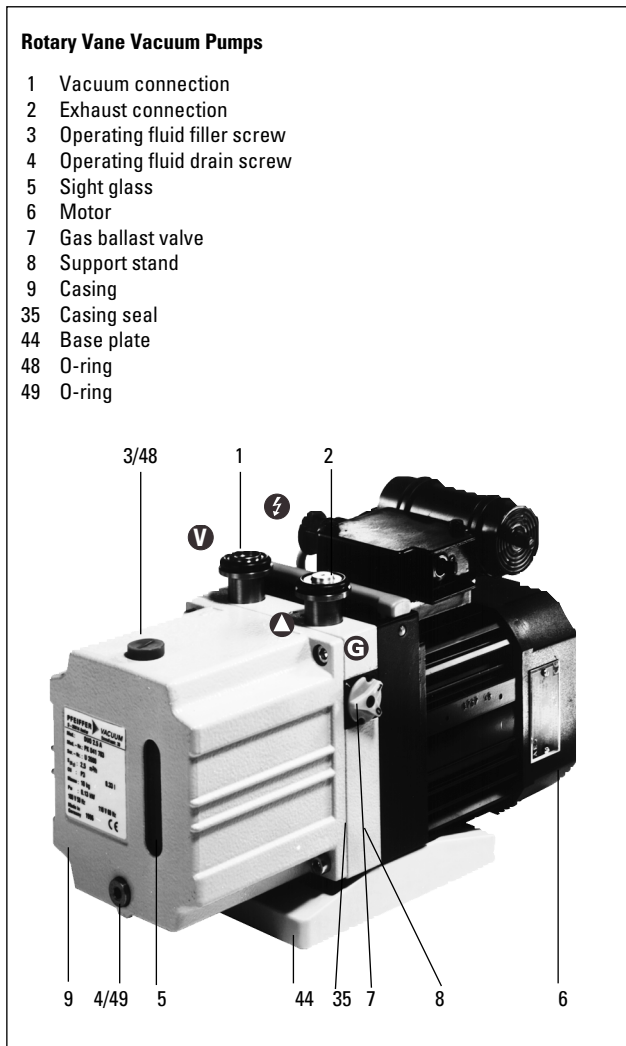

The Rotary Vane Vacuum Pumps are suitable for the generation of rough and medium vacuum in the laboratory and for all operations where small volume flow rates suffice. They can also be used as backing pumps for small diffusion or turbo molecular pumps.

Proper Use

- Rotary Vane Vacuum Pumps may only be used to generate vacuum.
- Do not pump corrosive or explosive gases (a special version for these operations is available on request).
- Do not operate the pumps where explosive processes are involved. This is only permitted with the "explosive" version of the pump.
- Using accessories not named in this manual is not permitted without authorisation from PFEIFFER.

Improper use will cause any rights regarding liability and guarantees to be forfeited.

2.2. Design

The single stage UNO 005 A/2.5 A and two stage DUO 2.5 A/AC Rotary Vane Vacuum Pumps are oil-immersed. The pump stages and motor are mounted on a support stand. Bearings and pumping chamber are supplied continuously with pump fluid which both seals and lubricates. Pump fluid, together with dirt and other particles, is expelled via the pump valve and returned to the pump fluid reservoir. Foreign matter and dirt particles are deposited on the floor of the casing so that only clean pump fluid flows into the pump circulation system. Intake ports, exhaust ports and gas ballast valve are located on the support stand. The direct drive, broad range voltage motor drives the pump via a coupling. A built-in, thermal protection switch protects the motor and the pump against overloading.

A hydraulically controlled high vacuum safety valve is located between the vacuum connection and the pumping system. The valve closes off the vacuum equipment without delay when the pump is at a standstill and vents the pump. The Rotary Vane Vacuum Pumps are in two versions available:

Standard versions:

**UNO 005 A,
UNO/DUO 2.5 A**

Version for Corrosive Gas Processes: DUO 2.5 AC

With regard to the Rotary Vane Pump DUO 2.5 AC please note the following divergences compared with the standard version:

- Corrosive gas type pumps are equipped with special materials.
- Corrosive gas type pumps are equipped with a special gas ballast valve (see section 4.5)
- Corrosive gas type pumps are operated with the synthetic pump fluid F5 as standard.

3. Installation

3.1. Preparations For Installation



Fill up with operating fluid before operating the first time (included in a separate pack in the delivery consignment).

When transporting, use only the handle provided for the purpose. When filled with operating fluid, do not tilt the pump otherwise operating fluid could escape via the vacuum and exhaust flanges.

3.2. Pump Set-Up And Location

- ➔ Where stationary installation is involved, anchor the pump on site.
- ➔ Sight glass 5 on the front side must be visible and the gas ballast valve readily accessible.
- ➔ When installing the pump in a closed housing, ensure there is sufficient air circulation.

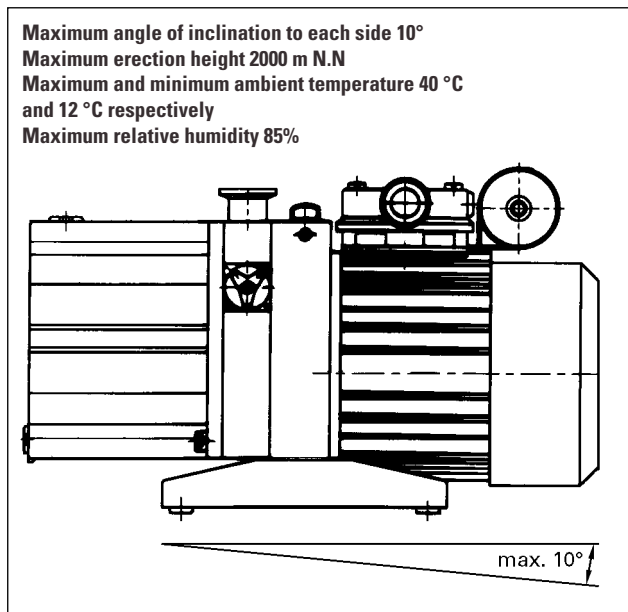

3.3. Connections, Vacuum Side

- ➔ Keep the connection between the vacuum chamber and pump as short as possible.
- ➔ Remove all scaling and loose particles from welded lines prior to assembly.
- To protect the pump, separators, filters and cooling traps etc. (see Section 9. Accessories) can be fitted upstream of the pump. However, this does mean that owing to the conductance value of the accessory, there is a reduction in volume flow rate.
- For the intake lines, metal or PVC hoses with small flanges are available for laboratory work.

3.4. Connecting The Exhaust Side



Pressure can rise to dangerous levels in exhaust lines. Therefore exhaust lines should not be fitted with shut-off units.

If, for internal works reasons, shut-off devices are fitted, or if there is a risk of a build up of excess pressure in the lines, observe all official accident prevention safety regulations.

- Lay minimum diameter exhaust lines of DN 10.
- If the exhaust gases are being extracted, the pressure of the exhaust must not fall below 200 mbar.
- Lay lines from the pump sloping downward so that no condensate can flow back into the pump. Otherwise fit a separator.
- Forces from the piping system may not be allowed to act on rotary vane pumps which are anchored. All piping to the pump must be suspended or supported.



Exhaust gases and vapours can be detrimental to health and/or can pollute the environment. For this reason, when working with toxic substances it is essential to ensure compliance with the applicable regulations. Only officially approved filter systems may be used to separate out these substances. This is also applicable to operations involving poisonous, chemically unstable, polymerising or peroxide forming gases (see Section 9 Accessories).

3.5. Connecting To The Mains Power Supply



Power connections ⚡ must comply with local regulations. Voltage and frequency information given on the rating plate must correspond to the mains voltage and frequency values.

- Voltage and frequency information given on the rating plate must correspond to the mains voltage and frequency values.
- The single phase drive motors of the UNO 005 A/2.5 A and the DUO 2.5 A/AC are fitted with a built-in thermal protection switch. A cable with connecting plug is fitted to the motor for mains connection purposes.
- Motors can be supplied with or without ON/OFF switch.
- As standard drive motors two single phase motors for the following tensions are suitable:
 - 230 V ± 15 % 50 Hz, and
 - 208 V ± 10 % 60Hz or
 - 100 V ± 10 % 50 Hz, and
 - 110 V ± 15 % 60 Hz.
- Other drive motors are available on request.

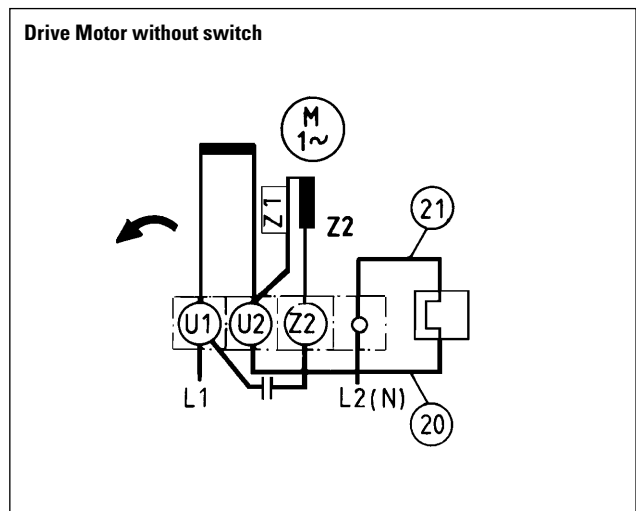
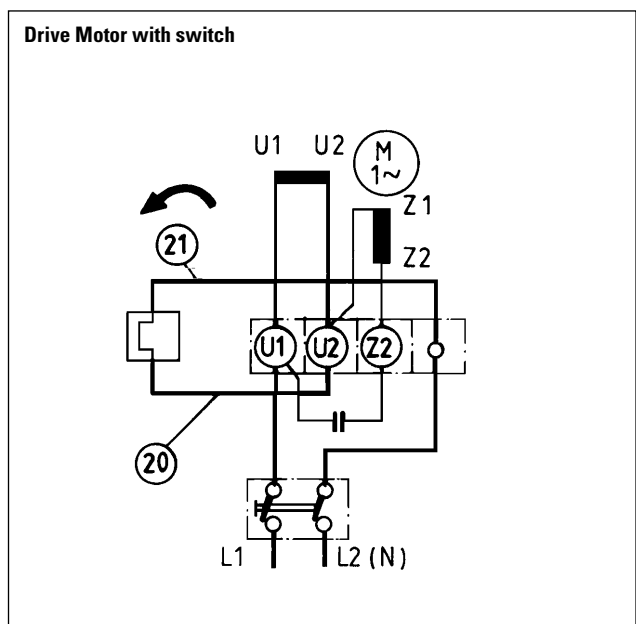

4. Operations

Rotary Vane Vacuum Pumps UNO 005 A/2.5 A, DUO 2.5 A/AC

1 Vacuum connection	8 Support stand
2 Exhaust connection	9 Casing
3 Operating fluid filler screw	35 Casing seal
4 Operating fluid drain screw	44 Base plate
5 Sight glass	48 O-ring
6 Motor	49 O-ring
7 Gas ballast valve	

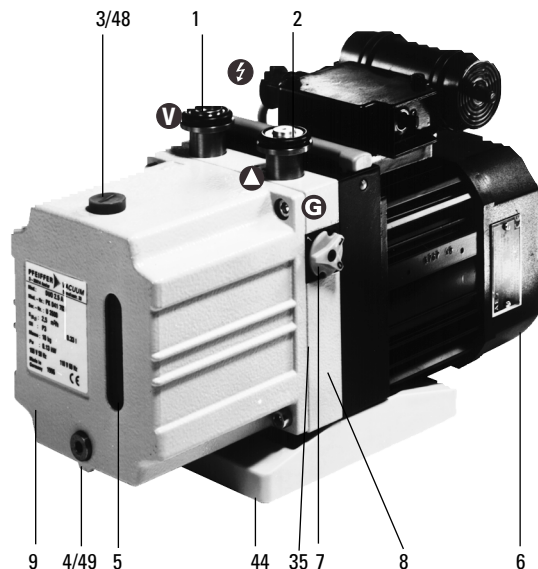

4.1. Filling Up And Checking The Operating Fluid



Standard version pumps are tested with operating fluid P3. Guarantees relating to attainment of final pressures and trouble free functioning apply only providing this operating fluid is used.

The delivery consignment contains sufficient operating fluid for one filling.

Pumps for special applications (e.g. for pumping corrosive gases) can be operated with special operating fluids such as F5, C100 and other Pfeiffer operating fluids. The use of such operating fluids requires prior authorisation from the manufacturer.

P3 must be disposed of in accordance with local waste disposal regulations.

- ➔ Remove operating fluid filler screw 3.
- ➔ Fill up with operating fluid so that the level is between the two markings on the sight glass or on the casing (for pumps with replaceable sight glass; also refer to rating plate for correct quantity).
 - The minimum level is the lower marking on sight glass 5.
- ➔ Replace operating fluid filler screw 3; be careful with O-ring 48.
- ➔ Check operating fluid level only when the pump is warm and running and vacuum connection 1 and gas ballast valve 7 and operating fluid filler screw are closed.

- In non-stop operations check operating fluid daily, otherwise whenever the pump is switched on; topping up pump fluid is possible when the pump is in final vacuum operations.



If there is a noticeable loss of pump fluid, the casing and the radial shaft seals should be checked for leaks (see Service Instructions).

Sight glass 5 with operating fluid level for the first filling and during operation

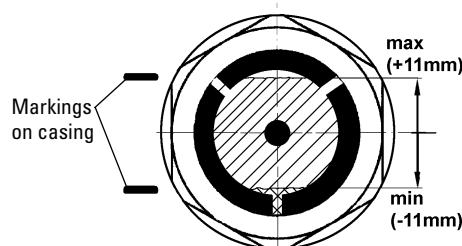

4.2. Switching The Pump ON And OFF

The pump can be switched ON and OFF in any pressure range. Maximum exhaust pressure 1.5 bar (absolute). Lowest start-up temperature, in compliance with German Industrial Standard DIN 28 426: +12°C.

On switching OFF (intake pressure < 750 mbar) the built-in high vacuum safety valve to the vacuum chamber closes automatically and the pump is vented.

The Working Of The High Vacuum Safety Valve

The automatically operating high vacuum safety valve 20 is open when the equipment is vented. When the pump is switched on, air intake is shut off via hydraulic pump 53 integrated in the pumping system and the safety valve remains in the open position owing to the action of the pressure spring.

At intentional or unintentional pump standstills, hydraulic valve 23 opens the air intake owing to absence of hydraulic pressure and presses valve head 24 against the vacuum side by virtue of the air streaming in. The system closes vacuum tight and simultaneously the pump is vented.

When the vacuum pump is switched on again, the intake of air is shut off by hydraulic valve 23 and the inner area of the high vacuum safety valve is evacuated. If the pressure in the valve has fallen far enough that the force of spring 27 is sufficient to press valve head 24 against the pressure prevailing in the system, the valve opens.

4.3. Pumping Dry Gases And Vapours

No special measures are necessary providing the correct pump version is being operated (selection of operating fluid, materials etc.).



To avoid condensation in the pump, vapours should only be pumped off when the pump is warm and with gas ballast valve open. Note pump water vapour compatibility levels under Section 8. Technical Data. When the process has been completed, allow the pump to continue running for about 30 minutes with open gas ballast valve for operating fluid regeneration purposes.

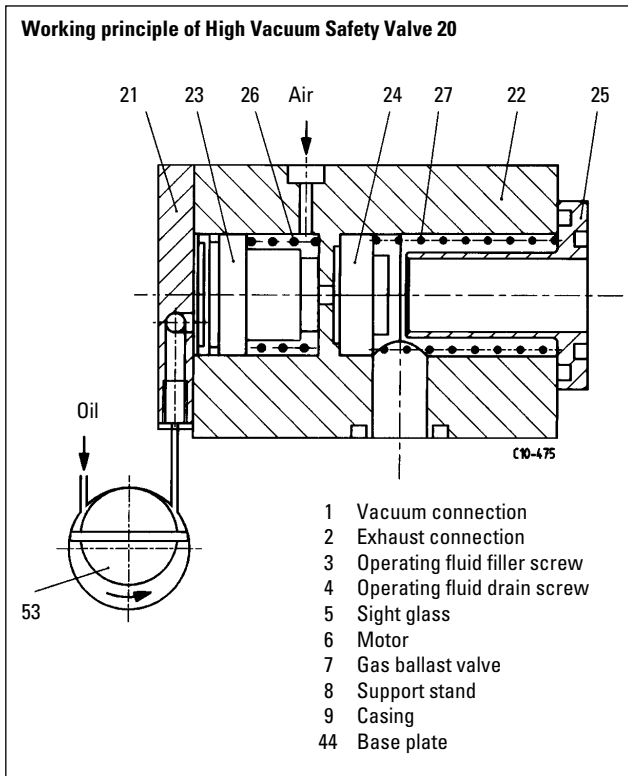

4.4. Gas Ballast Valve (Standard Version)

To avoid the condensation of vapours in the pump, air is periodically fed into the working chamber at the beginning of the compression phase via the gas ballast valve.

- Gas ballast valve 7 is shut when turning to the right to position 0–0 and open when turning to the left to position 1–1.

Intermediate settings are not possible.

If the pumping process requires the connection of flushing gas, an adapter connection G 1/8 can be provided for the gas ballast valve (available on request).

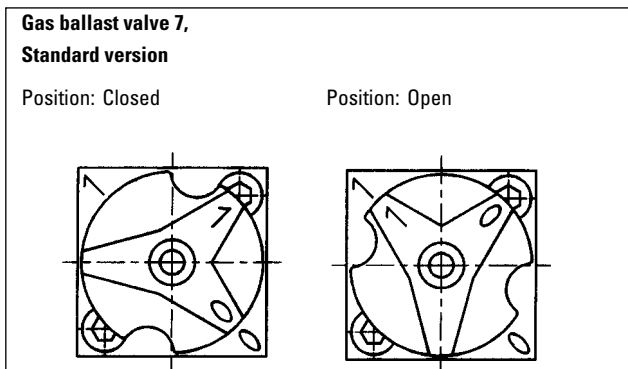

4.5. Gas Ballast Valve (For Corrosive Gas Processes)

Gas ballast valve 7 is equipped with a dosing unit 7.3 and a flushing gas connection 7.4.

The dosing unit is closed when turned fully clockwise and open when turned fully anti-clockwise. The amount of gas can be set at any required rate from maximum to minimum with a flow meter.

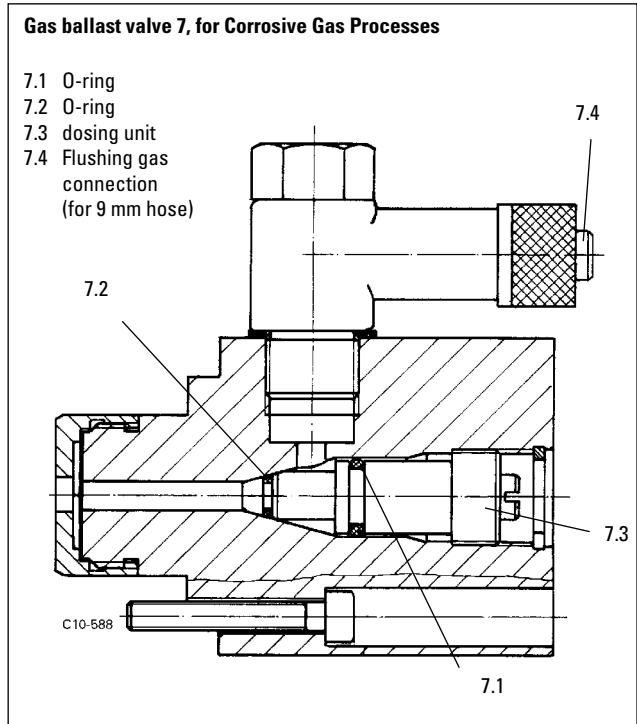

Please note:

Flushing gas must be connected when operating corrosive gas model pumps. The gas ballast valve must be open. Flushing gas pressure may not exceed 1.5 bar. The type of flushing gas is dependent on the medium being pumped. Our specialists would be pleased to give advice regarding the type and volume of flushing gas required.



When working with synthetic pump fluid, the manufacturer's directions for use must be observed. If F5 is heated to over 250°C, poisonous gases damaging to the respiratory system are produced. F5 must not be allowed to come into contact with tobacco products. When handling chemicals, the relevant manufacturer's instructions must be followed. Pump fluid which have been enriched with toxic or corrosive substances must be specially handled and all pertinent regulations must be observed.

4.6. Silencer

Silencer 40 is a nozzle inside the pump housing and cannot be altered; when dirty it should either be cleaned or replaced (see Service Instructions).

5. What To Do In The Case Of Breakdowns?

Problem	Possible Cause	Remedy
Pump doesn't attain final pressure	<ul style="list-style-type: none"> • Pump dirty • Operating fluid dirty 	<ul style="list-style-type: none"> • Clean the pump • Operate pump for a longer period with open gas ballast valve or change operating fluid • Repair leak
Unusual operating noises	<ul style="list-style-type: none"> • Leak in system • Silencer dirty • Pump system damage 	<ul style="list-style-type: none"> • Clean the silencer (see Service Instructions). • Request repair by PFEIFFER Service
Pump doesn't start	<ul style="list-style-type: none"> • Mains power missing • Ambient temperature <12 °C • Dirty pump stages • Damaged pump system 	<ul style="list-style-type: none"> • Check mains voltage and motor switch • Warm up pump • Request cleaning by PFEIFFER Service • Request repair by PFEIFFER Service

Any other repairs may only be carried out by qualified personnel in conjunction with the service instructions.

6. Maintenance

When carrying out servicing work, take the following precautions:



Always ensure the pump cannot be switched on when carrying out any work on the pump. If necessary, remove the pump from the system to carry out inspection work.

- ➔ Only dismantle the pump as far as is necessary in order to repair defects.
- ➔ Dispose of used operating fluid in compliance with local regulations.
- ➔ When working with synthetic operating media, toxic substances and substances contaminated with corrosive gases, the relevant instructions governing their use must be observed.
- ➔ Only use benzene or similar agents for cleaning pump parts. Do not use soluble cleaning agents.

6.1. Replacing The Operating Fluid

The rate of deterioration of the operating fluid depends on the pump applications.

- ➔ The level of deterioration of organic operating fluids (for example P3) can be read off from the colour scale in accordance with DIN 51578 on the supplementary sheet PK 800 219 BN/B, on request.
 - The colour scale enables precise colour determination.
- ➔ Fill a specimen in a test tube or some similar vessel and test by holding against the light.
- ➔ Where the discolouration is dark yellow to red brown (equivalent to 4 ... 5 on the scale) change operating fluid.



Where organic operating fluids, for example P3, are involved, the operating fluid should be changed at least once a year!

Replacing The Operating Fluid

- ➔ Switch off the pump.
- ➔ Unscrew operating fluid drain screw 4 and drain operating fluid.



The operating fluid temperature can be as high as 80 °C. During maintenance and repair work, process related toxic gases and vapours can escape from the operating fluid which may become contaminated with harmful substances (radioactive, chemical etc.).

Disposal of used operating fluid is subject to the relevant regulations.

- ➔ Screw in operating fluid drain screw 4.
- ➔ Allow pump to run for about 10 seconds with open vacuum flange.
- ➔ Drain off remaining operating fluid.
- ➔ In the case of serious contamination, the operating fluid will have to be changed several times.
- ➔ Screw in operating fluid drain screw 4 with O-ring 49.
- ➔ Fill in fresh operating fluid and check level as per section 4.1.



Operating fluid can contain substances from the medium pumped. Operating fluid must be disposed of in accordance with the local respective regulations.

Please request safety instruction data sheets for operating fluids from PFEIFFER or download from the INTRANET/INTERNET.

6.2. Shutting Down For Longer Periods

Should the pump have to be shut down for an longer period, the complete pumping system must be adequately protected against corrosion.

- ➔ Switch off pump.
- ➔ Unscrew operating fluid drain screw 4 and drain operating fluid as per Section 6.1.
- ➔ Screw in operating fluid drain screw 4; keep an eye on the position of the O-ring 49.
- ➔ Allow pump to run for about 10 seconds with open vacuum flange ④.
- ➔ Drain off remaining operating fluid.

7. Service

Do Make Use Of Our Service Facilities

In the event that repairs are necessary a number of options are available to you to ensure any system down time is kept to a minimum:

- Have the pump repaired on the spot by our Service Engineers;
- Return the pump to the manufacturer for repairs;
- Replace with a new value pump.

Local PFEIFFER representatives can provide full details.

Before returning:

- ➔ Please attach a clearly visible notice "Free of harmful substances" (both on the unit and also on the delivery note and any accompanying letters).

"Harmful substances" are substances and preparations as defined in the current harmful substances regulations and in the U.S.A. as "materials in accordance with the Code of Federal Regulations (CFR) 49 Part 173.240 Definition and Preparation".

We will carry out the decontamination and invoice this work to you if you have not attached this note. This also applies where the operator does not have the facilities to carry out the decontamination work. Units which are contaminated microbiologically, explosively or radioactively cannot be accepted as a matter of principle.

Fill Out The Declaration Of Contamination

- ➔ In every case the "Declaration Of Contamination" must be completed diligently and truthfully.
- ➔ A copy of the completed declaration must accompany the unit: any additional copies must be sent to your local PFEIFFER Service Center.

- ➔ Fill up pump with fresh operating fluid: filling level - upper end of sight glass 5.

If this amount of operating fluid is filled in, the level is extremely high but this is necessary to protect all parts of the pump against corrosion.



Before operating, the operating fluid must be reduced to its normal level.

Please get in touch with your local PFEIFFER representatives if there are any questions regarding contamination.



Decontaminate units before returning or possible disposal. Do not return any units which are microbiologically, explosively or radioactively contaminated.

Returning Contaminated Units

If contaminated have to be returned for maintenance/repair, the following instructions concerning shipping must be followed:

- ➔ Neutralise the pump by flushing with nitrogen or dry air.
- ➔ Seal all openings to the air.
- ➔ Seal pump or unit in suitable protective foil.
- ➔ Ship units only in appropriate transport containers.

Please Note:

Repair orders are carried out according to our general conditions of sale and supply. If repairs are necessary, please send the unit to your nearest PFEIFFER Service Center.

Contact Addresses And Service Hotline

Contact addresses and telephone numbers can be found on the back cover of these operating instructions.

8. Technical Data

Single Stage Two Stage		UNO 005 A	UNO 2.5 A	DUO 2.5 A/AC
Connection nominal diameter				
Input		DN 16 ISO-KF	DN 16 ISO-KF	DN 16 ISO-KF
Output		DN 16 ISO-KF	DN 16 ISO-KF	DN 16 ISO-KF
Nominal volume flow rate at				
50 Hz	m ³ /h	5,1	2,8	2,8
60 Hz	m ³ /h	5,8	3,3	3,3
Volume flow rate at				
50 Hz	m ³ /h	4,6	2,5	2,5
60 Hz	m ³ /h	5,1	2,9	2,9
Final pressure				
Total without gas ballast	mbar	$< 5 \cdot 10^{-2}$	$< 5 \cdot 10^{-2}$	$< 5,0 \cdot 10^{-3}$
Total with gas ballast	mbar	< 1	< 1	$< 6,0 \cdot 10^{-3}$
Max. pressure (in continuous operation)	bar	1,5	1,5	1,5
Water vapour compatibility	mbar	20	15	15
Water vapour capacity at 50/60 Hz	g/h	70/75	37	37
Noise level				
Without gas ballast	dB(A)	53	53	53
With gas ballast	dB(A)	55	53	53
Operating fluid	l	0,45	0,45	0,4
Max. permissible Operating temperature ¹⁾	°C	80	80	80
Rotation speed at 50 Hz	1/min	2800	2800	2800
Rotation speed at 60 Hz	1/min	3350	3350	3350
Rated power, motor	kW	0,13	0,13	0,13
Weight	kg	11	10,2	10,5
¹⁾ at 25°C ambient temperature and operating fluid P3				

8.1. Dimensions

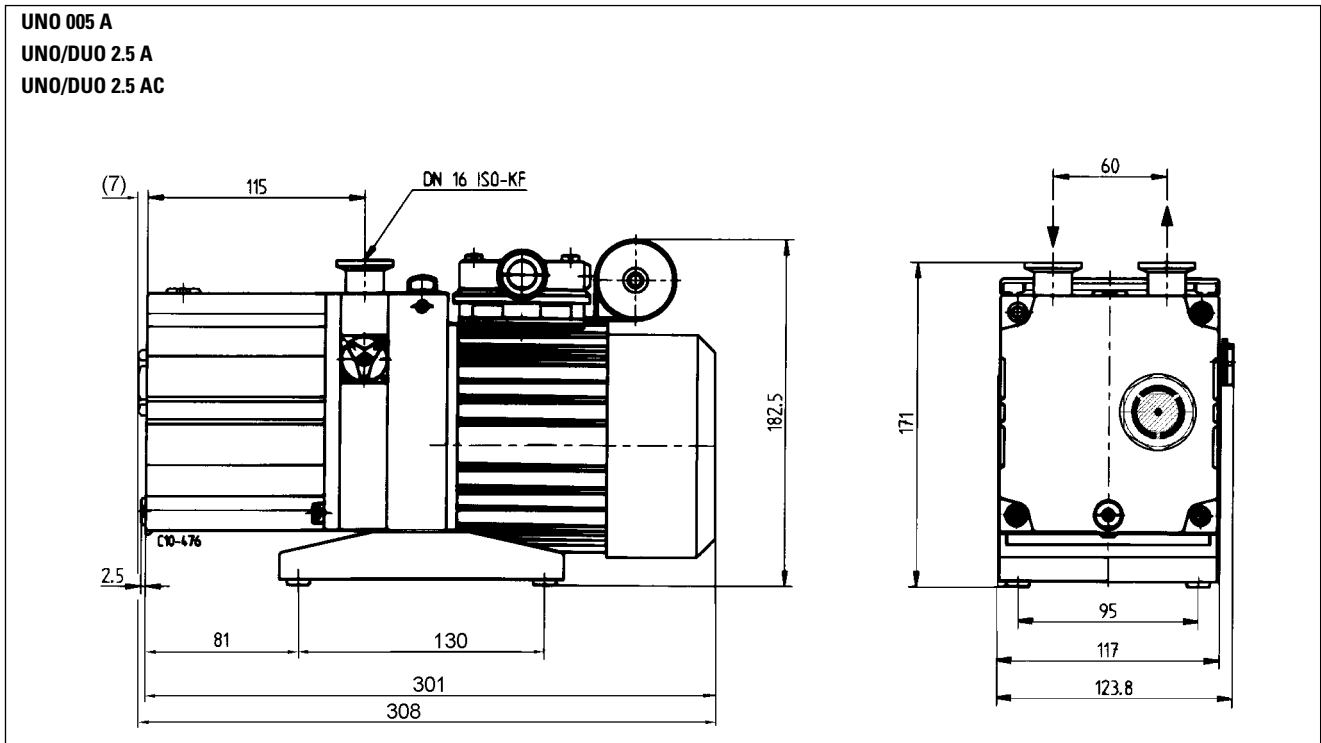

9. Accessories

Oil Mist Separator ONF 010 can be fitted to the exhaust port with the help of a reducing ring of the Rotary Vane Vacuum Pumps to prevent the expelled operating fluid mist polluting the air.

Oil Mist Separator ONF 010 and reducing ring are not included as standard and should therefore be ordered separately.

Pfeiffer's catalogue contains details of a comprehensive accessory programme which can both extend the range of application of the pump and provide protection against wear and tear under extreme operating conditions.

UNO 005 A UNO/DUO 2.5 A UNO/DUO 2.5 AC					
Pos.	Description	Size	Number	Comments/ Operating Instructions	Order Quantity
1	Öl Mist Separator ONF 010		PK Z40 002		
2	Reducing ring	DN 16/10 ISO-KF	BP 213 331-T		
3	Operating fluid check set OPS 001		PK Z90 013		

10. Spare parts

Spare parts UNO 005 A, Standard version						
Spare parts UNO/DUO 2.5 A, Standard version						
Pos.	Description	Pieces	Size	Number	Comments	Order Quantity
	Set of seals, UNO 005 A	1		PK 194 512-T		
	Set of seals, UNO/DUO 2.5 A	1		PK 194 057-T		
5	Sight glass with seal (replaceable)	1		P 0993 619		
6	Motor 110 V 50/60 Hz with switch	1		PK 194 114		
6	Motor 110 V 50/60 Hz without switch	1		PK 194 115		
6	Motor 230 V 50/60 Hz with switch	1		PK 194 116		
6	Motor 230 V 50/60 Hz without switch	1		PK 194 117		
7	Gas ballast valve	1		PK 194 012-U		
9	Casing, complete	1		PK 194 310-T		
35	Casing seal	1		PK 194 081		
48	O-ring, Vi	1	10x2,5	P 4070 166 PV		
49	O-ring, Vi	1	6x2,2	P 4070 088 PV		

Spare parts list DUO 2.5 AC, Version for Corrosive Gas Processes						
Pos.	Description	Pieces	Size	Number	Comments	Order Quantity
	Set of seals	1		PK 194 146-T		
6	Motor 110 V 50/60 Hz with switch	1		PK 194 114		
6	Motor 110 V 50/60 Hz without switch	1		PK 194 115		
6	Motor 230 V 50/60 Hz with switch	1		PK 194 116		
6	Motor 230 V 50/60 Hz without switch	1		PK 194 117		
7	Gas ballast valve	1		PK 194 144-U		
7.1	O-ring	1	5,0 x 1,5	P 4070 065 PV		
7.2	O-ring	1	2,1 x 1,0	P 4070 015 PV		
7.5	Valve flap	1		PK 194 017		
7.6	Elbow screw fitting	1		P 4131 001 D		
35	Casing seal	1		PK 194 154		
48	O-ring	1	10x2,5	P 4070 166 PV		
49	O-ring	1	6x2,2	P 4070 088 PV		

When ordering accessories and spare parts please be sure to state the full part number. When ordering spare parts please state additionally the unit type and unit number (see rating plate). Please use this list as an order form (by taking a copy).

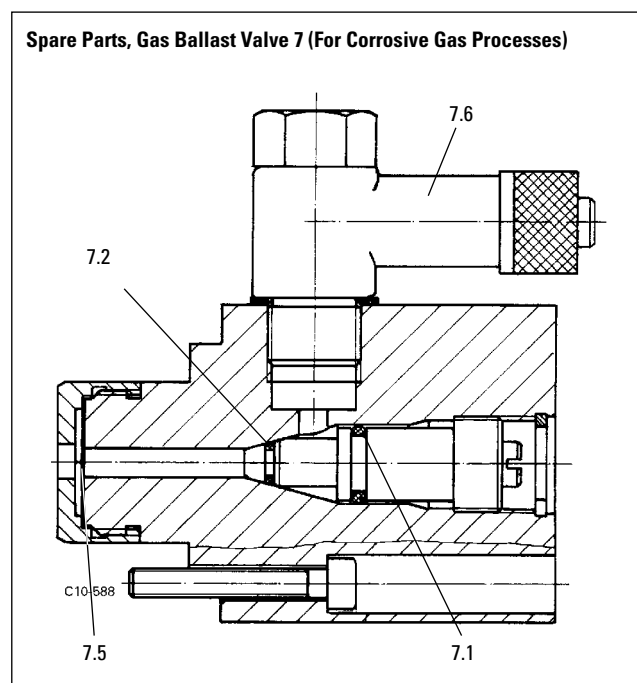
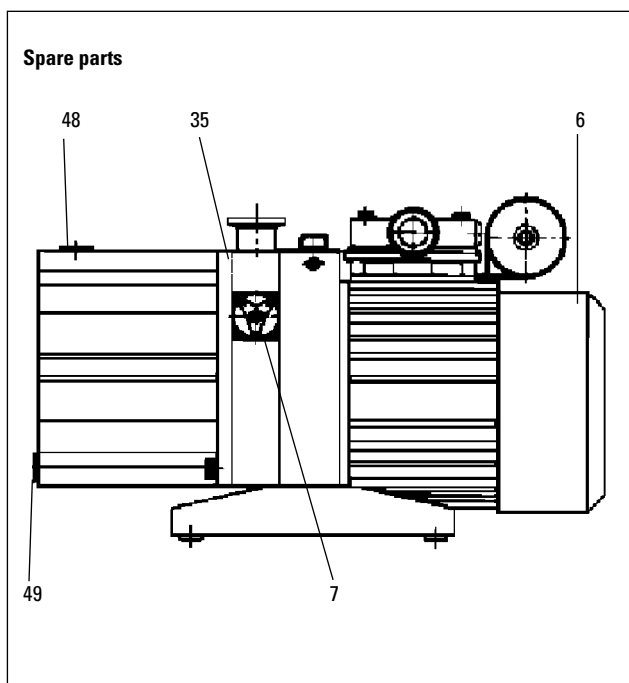

Declaration of Contamination of Vacuum Equipment and Components

The repair and/or service of vacuum components will only be carried out if a correctly completed declaration has been submitted. Non-completion will result in delay.

The manufacturer could refuse to accept any equipment without a declaration.

This declaration can only be completed and signed by authorised and qualified staff:

1. Description of component:

- Equipment type/model: _____
- Code No.: _____
- Serial No.: _____
- Invoice No.: _____
- Delivery Date: _____

2. Reason for return:

3. Equipment condition

- Has the equipment been used?
yes no
- What type of pump oil was used?

- Is the equipment free from potentially harmful substances?
yes (go to section 5)
no (go to section 4)

4. Process related contamination of equipment

- toxic yes no
- corrosive yes no
- microbiological hazard*) yes no
- explosive*) yes no
- radioactive*) yes no
- other harmful substances yes no

*) We will not accept delivery of any equipment that has been radioactively or microbiologically contaminated without written evidence of decontamination!

Please list all substances, gases and by-products which may have come into contact with the equipment:

Tradename Product name Manufacturer	Chemical name (or Symbol)	Danger class	Precautions associated with substance	Action if spillage or human contact
1.				
2.				
3.				
4.				
5.				

5. Legally Binding Declaration

I hereby declare that the information supplied on this form is complete and accurate. The despatch of equipment will be in accordance with the appropriate regulations covering Packaging, Transportation and Labelling of Dangerous Substances.

Name of Organisation: _____

Address: _____ Post code: _____

Tel.: _____

Fax: _____ Telex: _____

Name: _____

Job title: _____

Date: _____ Company stamp: _____

Legally binding signature: _____

⇒ **DE, AT**

Konformitätserklärung im Sinne folgender EU-Richtlinien:

- **Maschinen 89/392/EWG**
- **Elektromagnetische Verträglichkeit 89/336/EWG**
- **Niederspannung 73/23/EWG**

Hiermit erklären wir, daß das unten aufgeführte Produkt den Bestimmungen der EU-Maschinenrichtlinie 89/392/EWG - Anhang IIA, der EU-Richtlinie über elektromagnetische Verträglichkeit 89/336/EWG und der EU-Niederspannungsrichtlinie 73/23/EWG entspricht.
Die angewandten Richtlinien, harmonisierten Normen, nationalen Normen und Spezifikationen sind unten aufgeführt.

⇒ **GB, IE**

Declaration of conformity pursuant to the following EU directives:

- **Machinery Directive 89/392/EEC**
- **Electromagnetic Compatibility Directive 89/336/EEC**
- **Low Voltage Directive 73/23/EEC**

We hereby certify that the product specified below is in accordance with the provision of EU Machinery Directive 89/392/EEC - Annex II A, EU Electromagnetic Compatibility Directive 89/336/EEC and EU Low Voltage Directive 73/23/EEC.

The guidelines, harmonised standards, national standards and specifications which have been applied are listed below.

⇒ **BE, FR**

Déclaration de conformité conformément aux directives CE suivantes:

- **directive machine CE 89/392/CEE**
- **directive CE 89/336/CEE concernant la compatibilité électromagnétique**
- **directive CE 73/23/CEE concernant la basse tension**

Nous déclarons par la présente que le produit mentionné ci-dessous répond bien aux dispositions de la directive machine CE 89/392/CEE - appendice II A, la directive CE 89/336/CEE concernant la compatibilité électromagnétique et la directive CE 73/23/CEE concernant la basse tension. Les directives appliquées, normes harmonisées et les normes et spécifications nationales appliquées figurent ci-dessous.

⇒ **IT**

Dichiarazione di conformità ai sensi delle seguenti direttive UE:

- **Macchinari 89/392/CEE**
- **Compatibilità elettromagnetica 89/336/CEE**
- **Bassa tensione 73/23/CEE**

Si dichiara che il prodotto qui menzionato rispetta le disposizioni della direttiva UE sui macchinari 89/392/CEE - Appendice II A - della direttiva UE sulla compatibilità elettromagnetica 89/336/CEE e della direttiva UE sulla bassa tensione 73/23/CEE. Sono riportate in basso le direttive applicate, le norme standardizzate nonché le norme e le specifiche nazionali utilizzate.

⇒ **ES**

Declaración de conformidad al tenor de las siguientes Directivas de la UE:

- **Maquinarias 89/392/MCE**
- **Compatibilidad Electromagnética 89/336/MCE**
- **Baja Tensión 73/23/MCE**

Por la presente declaramos que el producto mencionado más abajo concuerda con las disposiciones resultantes de la Directiva 89/392/MCE de la UE sobre Maquinarias - Apéndice IIA, la Directiva 89/336/MCE de la UE sobre Compatibilidad Electromagnética y la Directiva 73/23/MCE de la UE sobre Baja Tensión. Las directivas aplicadas, normas armonizadas y las normas y especificaciones nacionales aplicadas se mencionan abajo.

⇒ **NL**

Verklaring inzake de conformiteit in de zin van de volgende EU-richtlijnen:

- **machinerichtlijn 89/392/EEG**
- **richtlijn over elektromagnetische compatibiliteit 89/336/EEG**
- **richtlijn over laagspanning 73/23/EEG**

Hiermee verklaren wij dat het hieronder genoemde produkt voldoet aan de bepalingen van de EU-machinerichtlijn 89/392/EEG - appendix II A, de EU-richtlijn over elektromagnetische compatibiliteit 89/336/EEG en de EU-richtlijn over laagspanning 73/23/EEG.

De toegepaste richtlijnen, geharmoniseerde normen en de toegepaste nationale normen en specificaties zijn hierna aangegeven.

⇒ **DK**

EF-konformitetserklæring i henhold til følgende EU-direktiver:

- **Maskiner 89/392/EWG**
- **Elektromagnetisk kompatibilitet 89/336/EWG**
- **Lavspænding 73/23/EWG**

Hermed erklærer vi, at det nedenstående produkt er i overensstemmelse med bestemmelserne i EU-maskindirektiv 89/392/EWG - tillæg II A, Eu-direktiv vedrørende elektromagnetisk kompatibilitet 89/336/EWG og EU-lavspændingsdirektiv 73/23/EWG.

De anvendte direktiver, harmoniserede standarder og de anvendte nationale standarder og specifikationer er angivet nedenfor.

⇒ **SE**

Konformitetsförklaring enligt följande EG-direktiv:

- **Maskindirektiv 89/392/EEC**
- **Elektromagnetisk tolerans 89/336/EEC**
- **Lågspänning 73/23/EEC**

Härmed förklarar vi, att den nedan nämnda produkten stämmer överens med EG's maskindirektiv 89/392/EEC - annex II A, EG's direktiv om elektromagnetisk tolerans 89/336/EEC och EG's lågspänningsdirektiv 73/23/EEC.

De riktlinjer, anpassade standarder, nationella standarder och specifikationer som har blivit accepterade, anges här nedan.



Vaatumusten mukaisuus vakuutus seuraavien EU-direktiivien mukaisesti:

- konedirektiivi 89/392/ETY
- sähkömagneettinen siedettävyyss 89/336/ETY
- pienjännite 73/23/ETY

Vahvistamme, täten, että allmainittu tuote vastaa EU-konedirektiivin 89/392/ETY - liite IIA, EU-direktiivin sähkömagneettinen siedettävyyss 89/336/ETY ja EU-pienjännitedirektiivin 73/23/ETY vaatimuksia.

Soveltamamme suuntaviitat, harmonisoidut standardit, kansalliset standardit ja rakennemääräykset on lueteltu alempana.



Declaração de conformidade, de acordo com as seguintes Directivas CE:

- Máquinas, na redacção 89/392/CEE
- Compatibilidade electromagnética, na redacção 89/336/CEE
- Baixa tensão, na redacção 73/23/CEE

Com a presente, declaramos que o produto abaixo indicado está em conformidade com as disposições pertinentes na Directiva CE para máquinas, na redacção 89/392/CEE - Apêndice II A, na Directiva CE sobre compatibilidade electromagnética, na redacção 89/336/CEE, e na Directiva CE sobre baixa tensão, na redacção 73/23/CEE. Abaixo, dá-se indicação das directivas aplicadas, das normas harmonizadas e das normas e especificações aplicadas no respectivo país.



Δήλωση συμφωνίας κατά το νόημα των εξής οδηγιών της Ε.Ε.:

- περί μηχανών 89/392/Ε.Ο.Κ.
- περί ηλεκτρομαγνητικής συμβατότητας 89/336/Ε.Ο.Κ.
- περί χαμηλής τάσης 73/23/Ε.Ο.Κ.

Με την παρούσα δήλωση βεβαιώνουμε ότι το κατωτέρω αναφερόμενο προϊόν ανταποκρίνεται στην οδηγία περί μηχανών της Ε.Ε. 89/392/Ε.Ο.Κ.- παράρτημα ΙΙ Α, στην οδηγία περί ηλεκτρομαγνητικής συμβατότητας της Ε.Ε. 89/336/Ε.Ο.Κ. και στην οδηγία περί χαμηλής τάσης της Ε.Ε. 73/23/Ε.Ο.Κ.

Οι εφαρμοσθέντες κανονισμοί, οι εναρμονισμένες προδιαγραφές και οι εφαρμοσθείσες εθνικές προδιαγραφές και τεχνικές προδιαγραφές αναφέρονται κατωτέρω:

Produkt/Product/Produit/Prodotto/Producto/Produkt/Produkt/Producto/ Προϊόν:

UNO 005 A
UNO/DUO 2.5 A
UNO/DUO 2.5 AC

Angewendete Richtlinien, harmonisierte Normen und angewendete, nationale Normen in Sprachen und Spezifikationen:

Guidelines, harmonised standards, national standards in languages and specifications which have been applied:

Les directives appliquées, normes harmonisées et les normes nationales appliquées en langues et spécifications:

Direttive applicate, norme standardizzate e norme nazionali utilizzate in lingue e specifiche:

Directivas aplicadas, normas armonizadas y normas nacionales aplicadas en idiomas y especificaciones:

Toegepaste richtlijnen, geharmoniseerde normen en toegepaste nationale normen met betrekking tot talen en specificaties:

Anvendte direktiver, harmoniserede standarder og de anvendte nationale standarder med sprog og specifikationer:

Directivas aplicadas, normas harmonizadas e normas aplicadas na linguagem e nas especificações do respectivo país:

Εφαρμοσθέντες κανονισμοί, εναρμονισμένες προδιαγραφές και εφαρμοσθείσες εθνικές προδιαγραφές σε γλώσσες και τεχνικές προδιαγραφές:

EN 292-1 **EN 60335-1, -41**
EN 292-2 **EN 61 010**
EN 294
EN 50 081-1
EN 50 082-1

Unterschriften/Signatures/Signature/Firme/Firmas/Handtekening/Underskrifter/Assinaturas/ Υπογραφές:

01. 04.1996

Geschäftsführer (W. Dondorf)
Managing Director
Gérant d'affaires
Gerente
Directeur
Administrerende Direktør
Verkställande Direktör
Gerente
Διευθύνων Σύμβουλος

Zentrale/Headquarters

Pfeiffer Vacuum GmbH

Emmeliusstrasse 33
D-35614 AsslarTelefon 06441/802-0
Telefax 06441/802-202

Hotline 06441/802-333

Internet:

<http://www.pfeiffer-vacuum.de>**Argentina**ARO S.A., Casilla de Correo 4890,
1000 Buenos Aires, telephone +54 / 1 331 3918,
telefax +54 / 1 331 3572**Australia**Balzers Australia Pty. Ltd., Level 1,
3, Northcliff Street, Milsons Point, NSW 2061,
telephone +61 / 2 9954 1925, telefax +61 / 2 9954 1939**Austria**Pfeiffer Vacuum Austria GmbH
Diefenbachgasse 35, A-1150 Wien,
telephone +43 / 1 8941 704, telefax +43 / 1 8941 707
Service Hotline: +43 / 1 8941704**Belgium / Luxemburg**Pfeiffer Vacuum Belgium N.V./S.A.
Minervastraat 14, B-1930 Zaventem
telephone +32 / 2 725 0525, telefax +32 / 2 725 0873
Service Hotline: +32 / 2 725 3545**Brazil**Elmi Tec
Assistencia Técnica e Representação S/C Ltda.
Rua Bernadino de Compos, 551
CEP 04620-002 São Paulo, SP - Brasil
telephone +55 / 11 532 0740
telefax +55 / 11 535 3598**Chile**BERMAT S.A., Coyuncura 2283, piso 6
Providencia, P.O. Box 9781, Santiago
telephone +56 / 2 231 8877,
telefax +56 / 2 231 4294**Colombia**Arotec Colombiana S.A., Carrera 15 No.38-17
P.O. Box 050 862, Santafe de Bogota / D.C.
telephone +57 / 1 288 7799, telefax +57 / 1 285 3604**Denmark**Pfeiffer Vacuum Scandinavia AB, Vesterengen 2,
DK-2630 Taastrup,
telephone +45 / 43 52 38 00
telefax +45 / 43 52 38 50**France**Pfeiffer Vacuum France SAS
45, rue Senouque, BP 139 F-78531 BUC Cedex
telephone +33 / (0)1 30 83 04 00
telefax +33 / (0)1 30 83 04 04**Germany**Pfeiffer Vacuum GmbH,
Emmeliusstrasse 33, D-35614 Asslar
telephone +49 / 6441 802 400
telefax +49 / 6441 802 399
Service Hotline: +49 / 6441 802 333**Great Britain**Pfeiffer Vacuum Ltd.
Bradbourne Drive, Tilbrook,
Milton Keynes, MK7 8AZ, United Kingdom
telephone +44 / 1 908 373 333
telefax +44 / 1 908 377 776**Greece**Analytical Instruments S.A., 1 Mantzarou St.,
GR-15451 Athens,
telephone +30 / 1 674 8973
telefax +30 / 1 674 8978**India**Pfeiffer Vacuum India Ltd.
25-E Nicholson Road, Tarbund
Secunderabad 500 009,
telephone +91 / 40 775 0014, telefax +91 / 40 775 7774**Israel**Eastronics Ltd., 11 Rozanis Street, P.O. Box 39 300,
Tel Aviv 61392,
telephone +972 / 3 6458 777,
telefax +972 / 3 6458 666**Italy**Pfeiffer Vacuum Italia S.p.a.
Via San Martino, 44 I-20017 RHO (Milano)
telephone +39 / 2 93 99 051, telefax +39 / 2 93 99 05 33**Japan**Hakuto Co. Ltd., C.P.O. Box 25,
Vacuum & Scientific Instruments Division
Tokyo Central 100-91,
telephone +81 / 3 32 258 910
telefax +81 / 3 32 259 009**Korea**Pfeiffer Vacuum Korea Ltd., 3F Haein Building 453,
Dokok-Dong, Kang Nam-Ku, Seoul, 135-270
telephone +82 / 2 3461 0671/5
telefax +82 / 2 3461 0676**Netherlands**Pfeiffer Vacuum Nederland BV
Veldzigt 30a, NL-3454 PW De Meern,
telephone +31 / 30 6666050, telefax +31 / 30 6662794**Peru**Ing. E. Brammert S.C.R.L., José Pardo 182,
Apartado 173, PE-18 Miraflores,
telephone +51 / 1 445 8178
telefax +51 / 1 445-1931**Poland**Softrade Sp.z.o.o, ul. Malwowa 35,
PL-60-175 Poznan, telephone +48 / 61 8677 168,
telefax +48 / 61 8677 111**Portugal**Unilaser Lda, Taguspark
Núcleo Central, sala nº 268, Estrada Cacém-
Porto Salvo, P-2780 Oeiras
telephone +351 / 1 421 7733
telefax +351 / 1 421 7744**Singapore**APP Systems Services Pte. Ltd, 2 Corporation Road
06-14 Corporation Place, Singapore 618494,
telephone +65 / 268 2024, telefax +65 / 268 6621**Spain**Tecnovac
Tecnologia de Vacio S.L., Ronda de Poniente, 6 Bajo F
Centro Empresarial Euronova
E-28760 Tres Cantos (Madrid)
telephone +34 / 91 804 11 34,
telefax +34 / 91 804 30 91**Sweden**Pfeiffer Vacuum Scandinavia AB
Magasinsgatan 35, Box 10412
S-43424 Kungsbacka
telephone +46 / 300 710 80
telefax +46 / 300 172 85
Service Hotline: +46 / 300 710 85**Switzerland**Pfeiffer Vacuum Schweiz S.A.
Förrlibuckstraße 30, CH-8005 Zürich
telephone +41 / 1 444 2255,
telefax +41 / 1 444 2266**South Africa**Labotec Pty Ltd., P.O. Box 6553,
Halfway House
1685 Midrand
telephone +27 / 11 315 5434
telefax +27 / 11 315 5882**Taiwan**S & T Hitech Ltd. Hsinchu office
No. 103, Hsien Chen 11th Street, Jubei City,
HsinChu County, Taiwan, R.O.C.
(zip/postal code: 302)
telephone +886 / 3 554 1020
telefax +886 / 3 554 0867**Thailand**S & T Enterprises (Thailand) Ltd.
18th Floor, Chokchai Int'l Bldg.
690 Sukhumvit Road
Klongton, Klongtoey
Bangkok 10110
telephone +662 / 259 4623
telefax +662 / 259 6243**U.S.A.**Pfeiffer Vacuum, Inc.
24 Trafalgar Square
Nashua, NH 03063-1988
USA
telephone +1/ 603 578 6500
telefax +1/ 603 578 6550**Venezuela**Secotec S.A., Apartado 3452, Caracas 1010-A,
telephone +58 / 2 573 8687
telefax +58 / 2 573 1932**Other countries**AVI - Applied Vacuum Industries GmbH
Leginglenstrasse 17A; CH-7320 Sargans
Switzerland
telephone +41 / 81 710 03 80
telefax +41 / 81 710 03 81**Scope of represented countries**Armenia, Azerbaijan, Bangladesh, Belarus, Bulgaria,
Cambodia, Estonia, Georgia, Hong Kong, Kazakhstan,
Kingdom of Nepal, Kirghizia, Latvia, Lithuania, Maldiva,
Philippines, P.R. China, Rumania, Russia, Tajikistan,
Turkmenistan, Ukraine, Uzbekistan, Vietnam**A.E.M.S.**Advanced Equipment Materials and Systems
P.O. Box 25
Föhrenweg 18
FL-9496 Balzers
telephone +41 / 75 380 0550
telefax +41 / 75 380 0551**Scope of represented countries**Bahrain, Egypt, Iraq, Iran, Jordan, Kuwait, Lebanon,
Lybia, Oman, Pakistan, Saudi-Arabia, Sudan, Syria,
Turkey, United Arab Emirates, Yemen