

## Oil Mist Filter



**ONF 4-20**

[idealtvac.com](http://idealtvac.com)  
**Ideal**  
vacuum products  
(505)872-0037  
[idealtvac.com](http://idealtvac.com)

PK 0169 BE/E (0906)

# Contents

<b>1. Safety Instructions .....</b>	<b>2</b>	<b>5. Technical Data .....</b>	<b>5</b>
1.1. For Your Orientation .....	2	<b>6. Spare Parts .....</b>	<b>5</b>
<b>2. Understanding the Oil Mist Filter ..</b>	<b>3</b>	<b>7. Accessories.....</b>	<b>5</b>
2.1. Application and Use .....	3	<b>Declaration Of Contamination .....</b>	<b>6</b>
2.2. Design.....	3		
<b>3. Installation and Operation .....</b>	<b>4</b>		
3.1. Fitting The ONF .....	4		
3.2. Fitting The Oil Return Line For The DUO 10 (PK 196 173-T) .....	4		
<b>4. Maintenance.....</b>	<b>5</b>		
4.1. Draining the Operating Fluid .....	5		
4.2. Changing the Filter Cartridge .....	5		

## 1. Safety Instructions

- ☞ Read and follow all instructions in this manual.
- ☞ Inform yourself regarding:
  - Hazards which can be caused by the pump;
  - Hazards which can be caused by your system.
- ☞ Observe the safety and accident prevention regulations.
- ☞ Regularly check that all accident prevention measures are being complied with.
- ☞ Do not carry out any unauthorised conversions on or alterations to the unit.
- ☞ When returning units, take note of shipping instructions in the Section "Service".

### 1.1. For Your Orientation

#### Instructions in the text

- ➔ Operating instructions: Here you have to do something!

#### Symbols used

The following symbols are used throughout in the illustrations:

- ⓪ Vacuum flange
- Ⓛ Exhaust flange

#### Position numbers

Identical components and accessories parts have the same position numbers in all illustrations.

Modifications reserved.

#### Pictogram definitions



Danger of personal injury.



Danger of burns from touching hot parts.



Danger of damage to the unit or to the system.



Attention to particularly important information on the product, handling the product, or to a particular part of the documentation.

#### Please note:

Current operating instructions are also available via [www.pfeiffer-vacuum.net](http://www.pfeiffer-vacuum.net).

## 2. Understanding the Oil Mist Filter

### 2.1. Application and Use

The oil mist filter is fitted to the exhaust port of the rotary vane vacuum pump. It reduces air pollution by operating fluid mist expelled in greater or smaller quantities (depending on the working pressure) from the pump.

The Oil Mist Filter ONF 4 - 20 is suitable for rotary vane vacuum pumps with smaller gas throughputs, up to a volume flow rate of 20 m<sup>3</sup>/h.

The ONF 4 - 20 is specially suitable for Pfeiffer Vacuum rotary vane vacuum pumps DUO 5/10/20.

The filter is not suitable where the pumping of corrosive gases and vapours or those gases which tend to polymerise or which can cause resinification of the oil mist filter is involved.

### 2.2. Design

A micro-fibre cylindrical filter cartridge is encased in plexiglass. A pressure plate is pressed down onto the filter element by a spring. The arrangement of pressure plate and spring is such that it works as an over-pressure valve and opens when the filter element becomes dirty.

Separated operating fluid can be observed through the plexiglass and drained off via the drain screw.

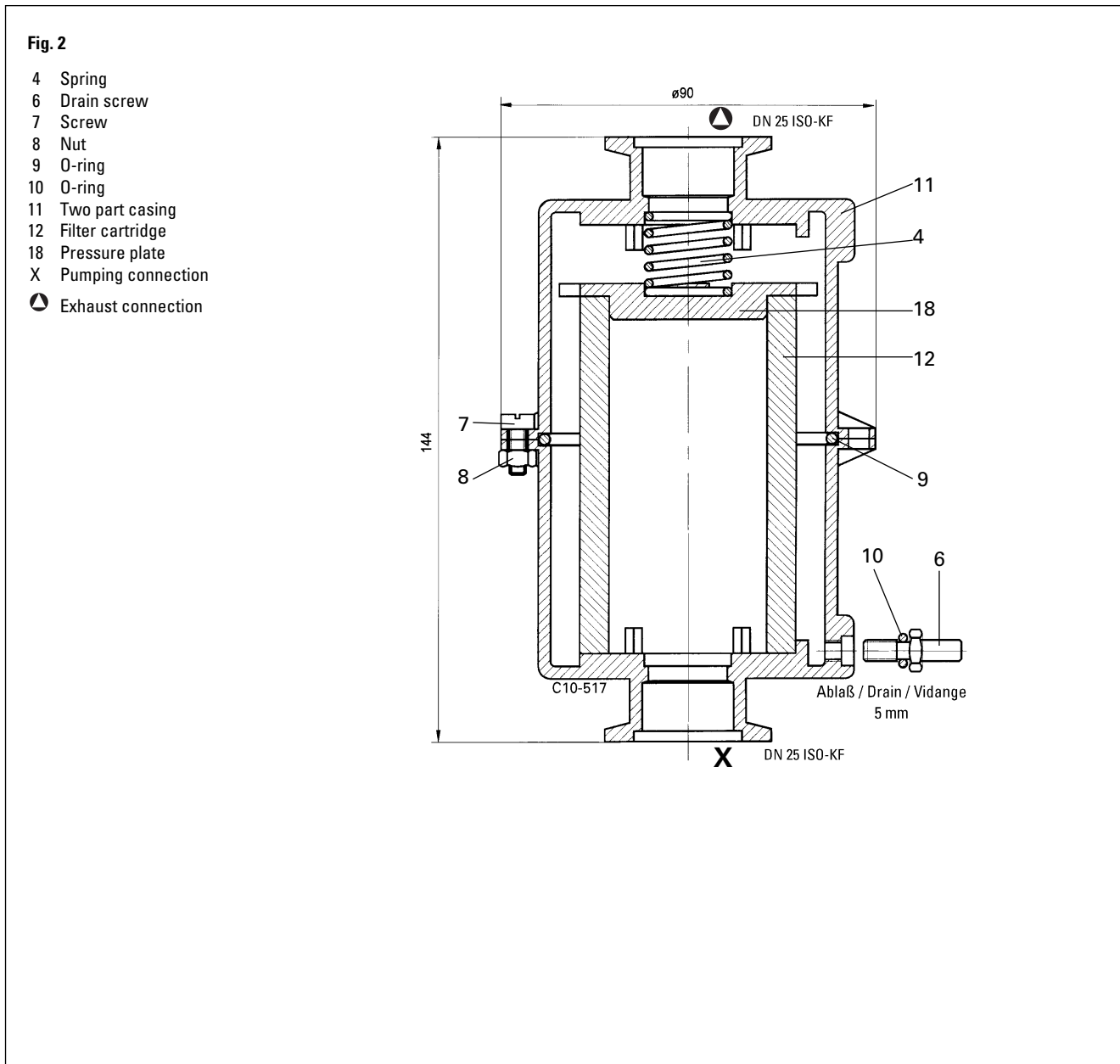

## 3. Installation and Operation

### 3.1. Fitting The ONF

ISO small flanges or ISO clamping flanges are provided on the input and output ports for connecting the oil mist filter.

- ➔ The flange marked with an "X" in Fig. 2 should always be connected facing the pump.



Avoid stress from the connecting lines acting on the pump.



As a result of differences in temperature between the pump and the oil mist filter or where the application involves the pumping of condensable vapours, condensed vapour (e.g. water) is deposited in the ONF. Condensate returned via the oil return line causes a deterioration in the quality of the pump operating fluid. Any operating fluid which has been enriched with condensate should be drained off in accordance with the instructions in Section 3.1.

- ➔ drain off or return separated operating fluid if the oil in the oil mist filter becomes foamy because of a high gas throughput.



If gases are being pumped which should not be allowed to escape into the atmosphere an exhaust line must be fitted.

The exhaust line should be laid so that no excess pressure can build up in it.

### 3.2. Fitting The Oil Return Line (PK 196 173 -T)

#### Fitting

- ➔ Drain off any operating fluid from the ONF by turning out the operating fluid drain screw 6.
- ➔ Unscrew operating fluid drain screw 6 on the ONF, drain off any operating fluid and screw in hose nipple 220 in place of the drain screw 6; take care with the O-ring 137.
- ➔ Dismantle gas ballast valve 42 from the pump.
- ➔ Re-fit the gas ballast valve with intermediate flange 45 and screw tight with longer screws; take care with the two O-rings 148.
- ➔ Screw hose nipple 220 into intermediate flange 45; take care with O-ring 138.
- ➔ Fit oil return hose 222 both sides on the hose nipples and tighten with hose clips 223.



The function of the oil return system to the vacuum pump is only safeguarded providing the rotary vane pump working pressure is < 100 mbar. Long evacuation phases with high intake pressures should also follow longer operating phases with lower working pressures (< 100 mbar).

#### ONF with the oil return system (PK 196 173-T)

11 Casing, zweiteilig	148 O-ring
42 Gas ballast valve	220 Hose nipple with nozzle
45 Intermediate flange	221 Hose nipple
137 O-ring	222 Oil return hose
138 O-ring	223 Hose clip

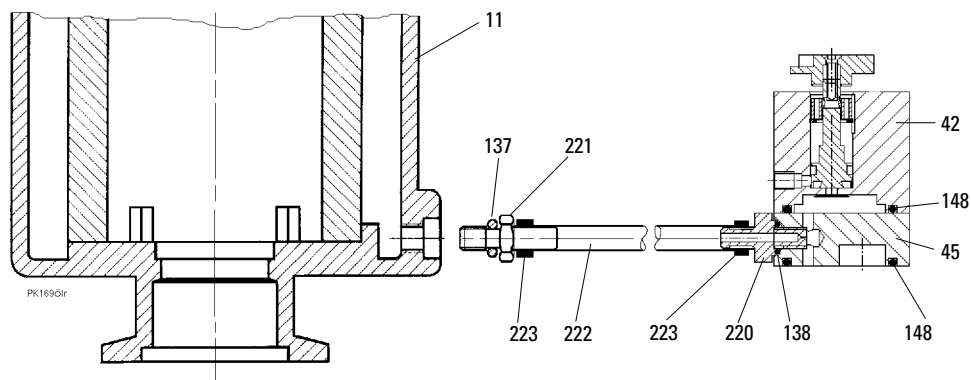

## 4. Maintenance

### 4.1. Draining the Operating Fluid



Toxic gases and vapours can escape from the pump fluid which may also become enriched with substances harmful to health (radioactive, chemical etc.) during the pumping of certain media.

Operating fluid which has been enriched with toxic or aggressive substances must be treated carefully. Compliance with all relevant regulations is essential.

If the operating fluid rises too high in the oil mist filter (filter cartridge half-full) it must be drained off.

- ➔ Unscrew drain screw 15.
- ➔ Drain operating fluid.



If the operating fluid is uncontaminated it can be re-used in the vacuum pump.

### 4.2. Changing the Filter Cartridge

It is necessary to change the filter cartridge if oil mist forms on the exhaust flange , or if the exhaust pressure increases to the point where the baffle, which operates as an over-pressure valve, opens.

#### Dismantling

Before proceeding with dismantling the oil mist filter, the connected vacuum pump must be disconnected.

- ➔ Unscrew screws 7; take care to the pre-stressing of the compressing spring.
- ➔ Remove casing upper part from lower part, take care with seal 9.
- ➔ Remove filter cartridge 12 from the casing.
- ➔ Once the cartridge has been replaced, assembly is in reverse order.

## 5. Technical Data

Technical Data		
Capacity	l	0,04 (filter cartridge half-full)
Separation level	%	99,98
Permissible working pressure	bar	1,5
Weight	kg	0,2

## 6. Spare Parts

Pos.	Description	Peace	Dimensions	Number	Comments	Ordering quantity
	Maintenance kit	1		PK E17 001 -T		
4	Spring	1	P 0920 554 E			
9	O-ring	1	66,27 x 3,53	P 4070 959 PV		
10	O-ring	1	4,48 x 1,78	P 4070 047 PV		
12	Filter cartridge	1		PK 005 627		
18	Pressure plate	1		P 0920 553 E		
137	O-ring	1	5 x 1,5	P 4070 065 PV		
138	O-ring	1	6 x 2,2	P 4070 088 PV		
148	O-ring	1	27 x 2,5	P 4070 465 PV		
220	Hose nipple with nozzle	1		PK 194 235		
221	Hose nipple	1		PK 194 317		
222	Oil return hose	1	0,5 m, 4/6	P 2354 052 MV		
223	Hose clip	2	SM5, B6 - W4	P 4165 500 AY		

## 7. Accessories

Description	Type	Number	Ordering quantity
Retrofit kit oil return unit	ONF 4-20	PK 196 173 -T	





# Vacuum is nothing, but everything to us!



**Turbopumps**



**Rotary vane pumps**



**Roots pumps**



**Dry compressing pumps**



**Leak detectors**



**Valves**



**Components and feedthroughs**



**Vacuum measurement**



**Gas analysis**



**System engineering**



**Service**

**PFEIFFER**  **VACUUM**

Pfeiffer Vacuum Technology AG · Headquarters/Germany

Tel. +49-(0) 64 41-8 02-0 · Fax +49-(0) 64 41-8 02-2 02 · [info@pfeiffer-vacuum.de](mailto:info@pfeiffer-vacuum.de) · [www.pfeiffer-vacuum.net](http://www.pfeiffer-vacuum.net)