

Mechanical Oil Filters OF 4-25 and OF 40-65 / Chemical Oil Filters CF 4-25 and **CF 40-65**



OF 4-25 mechanical oil filter

Since there is a pressure-lubrication system with an oil pump in every TRIVAC B, it is possible to connect main flow oil filters.

These filters are available either for mechanical filtering (OF types) or combined chemical/mechanical filtering (CF types).

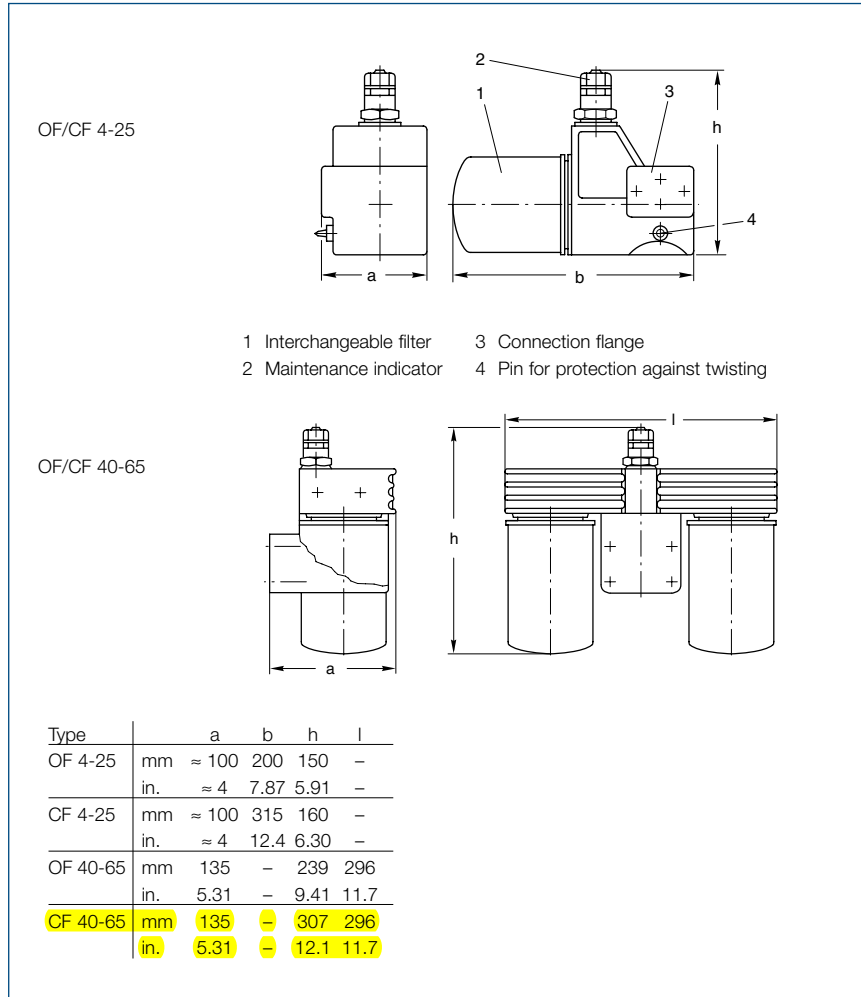

Dimensional drawings for the OF mechanical oil filters and CF chemical oil filters

Advantages to the User

- Main flow oil filter
- Longer service life for the oil depending on the type of application
- Can be installed without problems to the TRIVAC B
- Hose connections are not required
- Easily interchangeable filters
- Only a small amount of oil needs to be added when changing the filters
- Expansion of the range of applications in case of special requirements

- Same casing for OF and CF types
- Greater reliability by standard maintenance indicator
- Built-in bypass valve
- Owing to the highly effective adsorbent for polar substances, an up to ten-fold adsorption effect is attained over normal bleaching earth (CF)
- Prevents mechanical damage to the pump

Typical Application

- Separation of fine particles from the pump's oil (sizes between 5 and 10 µm (OF))



Technical Data		OF 4-25	CF 4-25	OF 40-65	CF 40-65
Connection to pump	TRIVAC	D 4/8 B, D 16/25 B	D 4/8 B, D 16/25 B	D 40/65 B	D 40/65 B
Nominal throughput	l x h ⁻¹	900	900	2000	2000
Separation					
mechanical oil filter	µm	5 to 10	5 to 10	5 to 10	5 to 10
chemical oil filter	µm	to 3	to 3	to 3	to 3
Permissible operating pressure	bar (psig)	2.5 (21.7)	2.5 (21.7)	2.5 (21.7)	2.5 (21.7)
Opening pressure, non-return valve	bar (psid)	0.12 (1.7)	0.12 (1.7)	0.12 (1.7)	0.12 (1.7)
bypass valve	bar (psid)	2.5 ± 0.3 (21.7 ± 4.3)	2.5 ± 0.3 (21.7 ± 4.3)	2.5 ± 0.3 (21.7 ± 4.3)	2.5 ± 0.3 (21.7 ± 4.3)
Topping up amount during					
first time installation	l (qt)	1 (1)	1 (1)	2.5 (2.6)	2.5 (2.6)
filter exchange	l (qt)	1 (1)	1 (1)	2 (2.1)	2 (2.1)
Weight, ready for operation, dry	kg (lbs)	4.0 (8.8)	4.0 (8.8)	10 (22.1)	10 (22.1)
Ordering Information		OF 4-25	CF 4-25	OF 40-65	CF 40-65
Mechanical oil filter		Part No. 101 91	–	Part No. 101 92	–
Chemical oil filter		–	Part No. 101 96	–	Part No. 101 97
WF 4-25 interchangeable filter, paper, 0.5 l (0.5 qt)		Part No. 189 91	–	–	–
WF 40-65 interchangeable filter, paper 0.75 l (0.8 qt)		–	–	Part No. 189 92 (2x)	Part No. 189 92 (2x)
WF Alu 4-65 interchangeable filter, paper and Al ₂ O ₃ , 1 l (1 qt)		–	Part No. 189 96	–	Part No. 189 96 (2x)