

a clear edge

nXDS dry scroll pump

Ideal
vacuum products
www.idealvac.com

 **EDWARDS**

Vacuum science... product solution.

a clear edge

the intelligent choice



Edwards nXDS is the great new shape of dry vacuum pumping

Edwards, a leading innovator in vacuum pump technology, is proud to present the new nXDS dry scroll pump range. With exceptional pumping capability, ultimate vacuum performance and state-of-the-art design features, Edwards nXDS is the best performing pump in its class.

The nXDS is up to 20 times quieter than other pumps. Its intelligent control functions and up to five year service interval offer low cost of ownership, making it the small dry pump of choice for today's most advanced technologies.

Features and benefits

- Advanced scroll-form and tip-seal technologies deliver best-in-class vacuum performance
- Quiet operation 52 dB(A) for minimal environmental impact
- Intelligent and easy to use control functions with simple operation
- Up to five year service interval for low cost of ownership
- Hermetically sealed for a lubricant-free vacuum environment
- Pump range includes 6, 10, 15 and 20 m³h⁻¹



Applications

Mass spectrometry

GCMS, LCMS, ICPMS, MALDI, RGA, surface science, leak detectors

Electron microscopy

TEM, SEM, sample coaters

Sample preparation

Gel dryers, glove boxes, rotary evaporators, centrifuges

Research and development

Chamber evacuation, coating systems, turbopump backing

High energy physics

Beam Lines, accelerators, mobile pump carts, turbopump backing, laser evacuation

Industrial

Gas recovery and recirculation, glove boxes, brake line and air conditioning evacuation, coating systems, freeze drying, gas bottle filling/emptying, refrigeration system manufacture, degassing/curing (oil, epoxy resin)

Semiconductor

Load locks and transfer chambers, turbopump backing

Chemical

Gel dryers, glove boxes, rotary evaporators, centrifuges, solvent recovery, distillation/extraction/filtration

Performance

nXDS has been designed to combine the latest advances in Scroll technology with an intelligent inverter drive coupled with the long established truly dry hermetically sealed mechanism of the XDS series.

Class leading pumping speeds are an improvement over existing XDS models and, with the inverter drive, are of course consistent worldwide. Likewise, ultimate vacuum pressures which are below 10⁻² mbar are now comparable with those of oil-sealed rotary vane pumps – without the inconvenience of oil.

Hermetic sealing ensures that the vacuum environment is not contaminated by bearing lubricant and conversely, the bearings are not contaminated by any process gas being pumped.

Quiet running

The modern laboratory is often a busy place with many other appliances running, all contributing to the noise background. With its low noise power level of 52 dB(A), the nXDS pump makes only a very small contribution to the total. This level is up to twenty times less than those of competitor products.

nXDS is available in four sizes:

- nXDS6i
- nXDS10i
- nXDS15i
- nXDS20i

Other variants

For more aggressive applications, 'C' Variants are available which feature Chemraz® internal valves and stainless steel fittings for extra protection from the pumped media.

R variants are available for specialist applications such as gas recirculation, rare gas pumping and recovery or other applications where the dilution of the pumped gas is undesirable, or where sealing is integral to minimising potential gas loss.

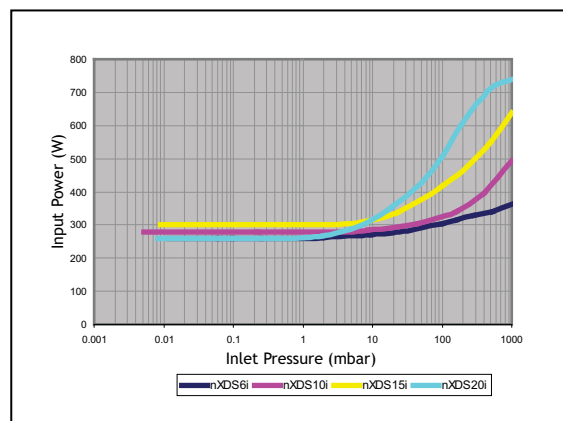
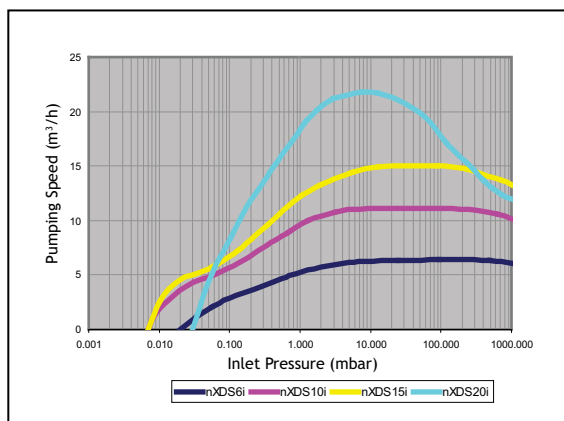

nXDS sectional view

Optimum bearing placement for long lifetime and easy replacement

High efficiency radial air-gap motor for low power consumption

Wide range voltage input with automatic selection for simple operation

Easy to use manual control buttons

Standby speed control buttons for efficient process tuning

USB port for future connectivity

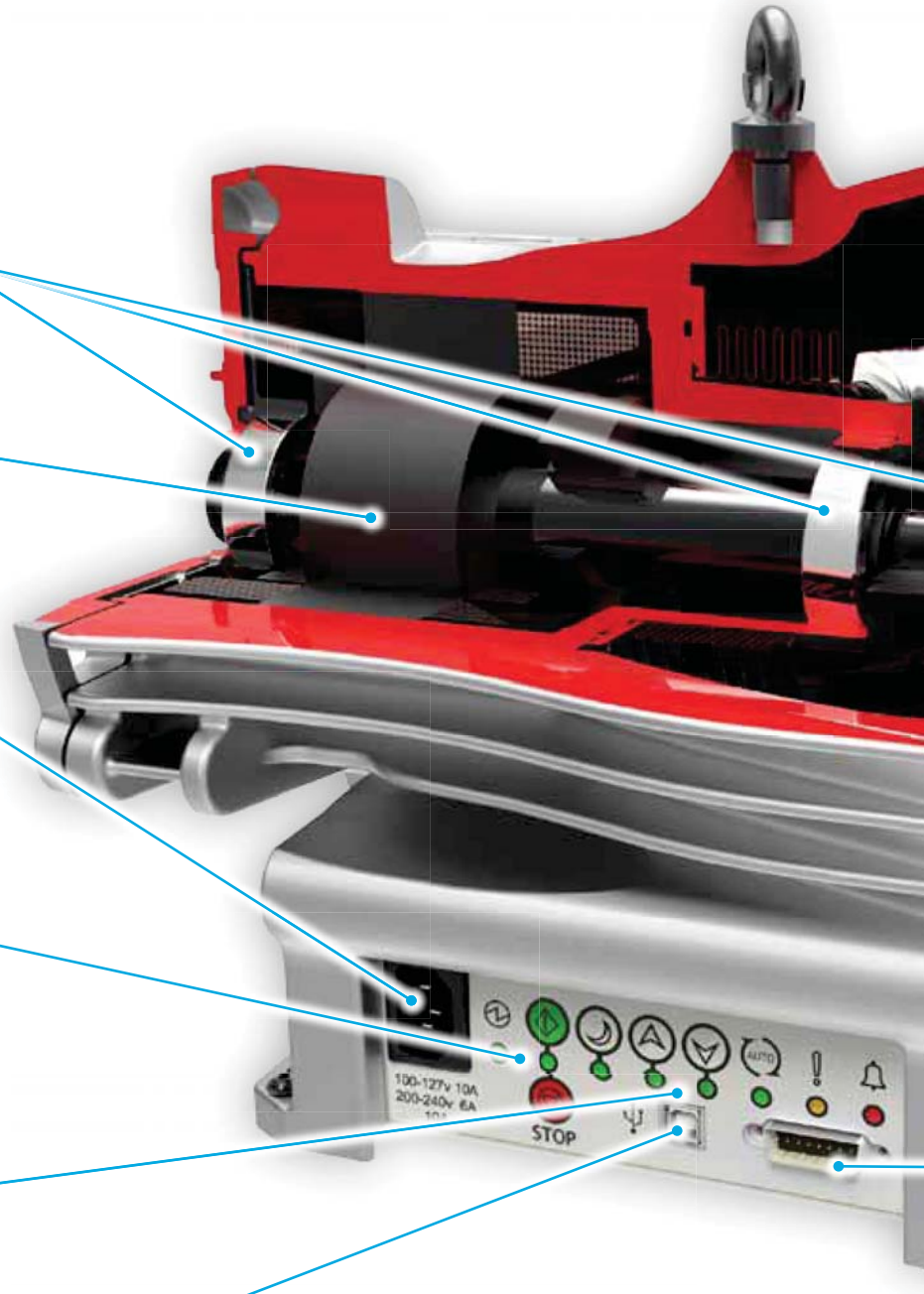

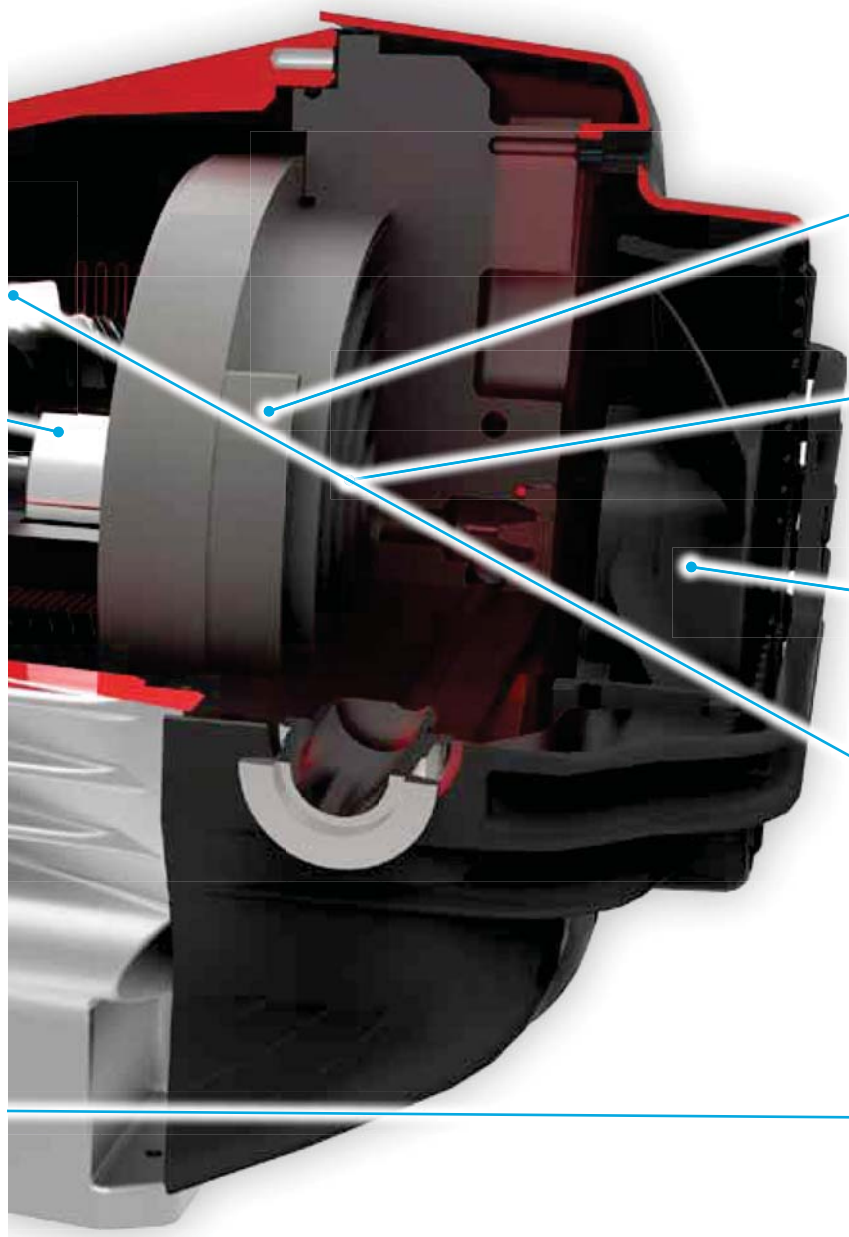

Optimised scroll profiles for each model to maximise performance

Advanced tip-seal technology for long service lifetime

Thermally controlled fan for reduced noise

Hermetic bellows sealing for contamination free vacuum

Remote control interface for convenience of operation



Technical data

		nXDS6i	nXDS10i	nXDS15i	nXDS20i
Nominal rotational speed		1800 rpm			
Displacement	m ³ h ⁻¹ (ft ³ min ⁻¹)	6.8 (4.0)	12.7 (7.5)	17.1 (10.1)	28.0 (16.5)
Peak pumping speed	m ³ h ⁻¹ (ft ³ min ⁻¹)	6.2 (3.6)	11.4 (6.7)	15.1 (8.9)	22.0 (13.0)
Ultimate vacuum (total pressure)	mbar (Torr)	0.020 (0.015)	0.007 (0.005)	0.007 (0.005)	0.030 (0.022)
Minimum standby rotational speed	rpm	1200			
Speed control resolution (percentage of full rotation speed)	%	1			
Max inlet pressure for water vapour	mbar	35	35	35	20
Max water vapour pumping rate	gh ⁻¹	110	145	280	220
Maximum continuous inlet pressure	mbar	200	200	200	50
Voltage input	V	100-127, 200-240 (+/-10%)			
Voltage frequency	Hz	50/60			
Motor power 1-ph*	W	260	280	300	260
Power connector 1-ph		IEC EN60320 C13			
Recommended fuse		10A, 250Vac rms			
Weight	kg (lb)	26.2 (58)	25.8 (57)	25.2 (56)	25.6 (56)
Inlet flange		NW25			
Exhaust flange		NW25			
Noise level**	dB(A)	52			
Vibration at inlet flange	mms ⁻¹ (rms)	< 4.5			
Leak tightness (static)	mbar ls ⁻¹	< 1x10 ⁻⁶			
Operating temperature range	°C (°F)	+10 C to +40 (+41 to +104)			

* Typical. See graphs on page 6.

** For low fan speed, typical at ultimate end when load/ambient conditions allow.

Pumping speed and power curves

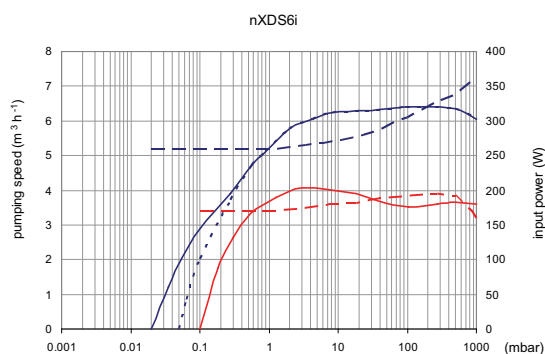

— normal pumping speed - - - min standby power
- - - normal full power — min standby speed
· · · normal GB speed

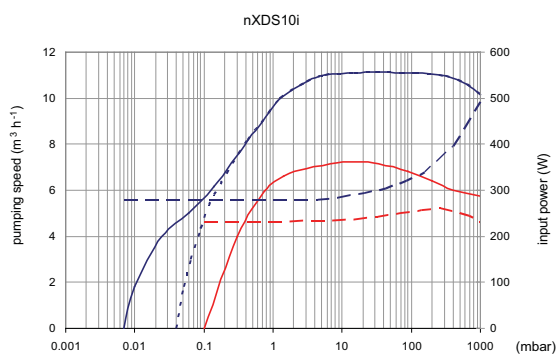

— normal pumping speed - - - min standby power
- - - normal full power — min standby speed
· · · normal GB speed

Dimensions

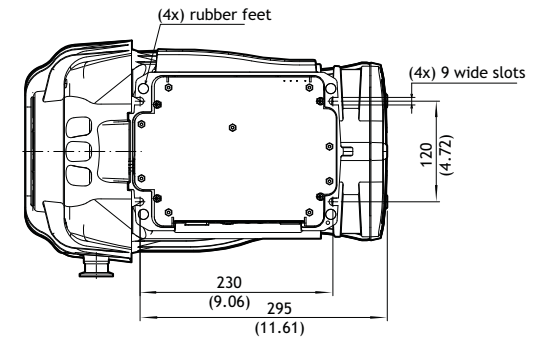
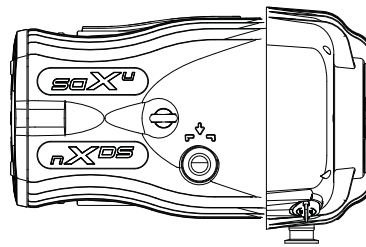
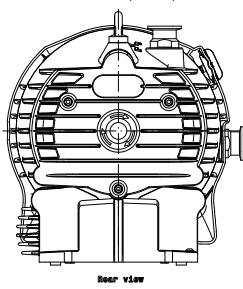
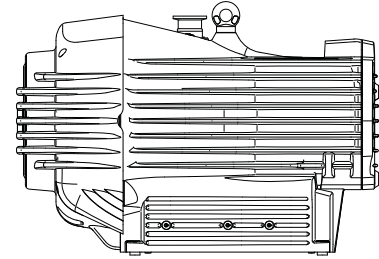
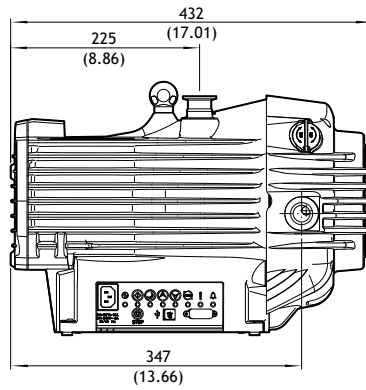
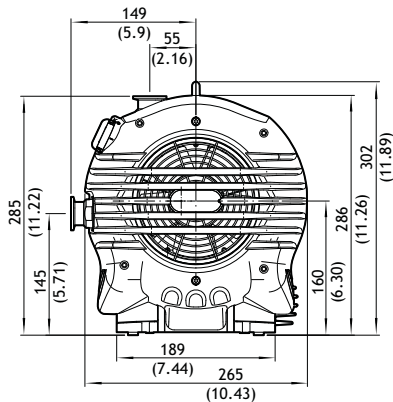

All variants are the same
Dimensions in mm (in)

nXDS15i

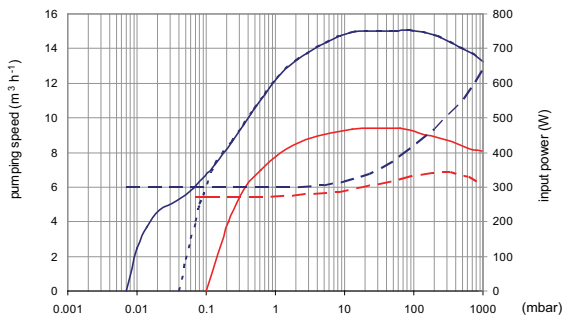

— normal pumping speed
 - - - normal full power
 ···· normal GB speed
 - - - min standby power
 — min standby speed

nXDS20i

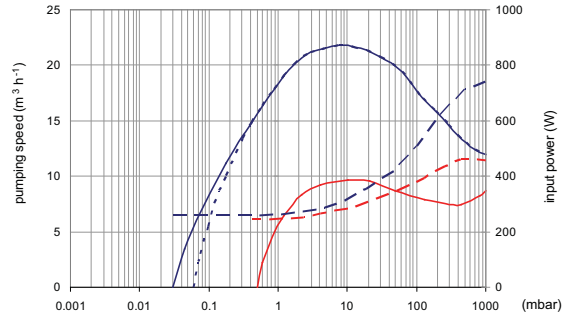

— normal pumping speed
 - - - normal full power
 ···· normal GB speed
 - - - min standby power
 — min standby speed

Pump controller

The advanced controller allows for several modes of control:

Manual

Push button START, STOP and STANDBY. Accurate speed control of 1% of maximum running speed.

Parallel remote

From your own control system via the 15 way d-sub connector giving the same START, STOP and STANDBY with the option of analogue speed control.

Serial communication remote

Option of either RS232 or RS485 with a choice of Edwards' proprietary 'DX' protocol or industry standard Modbus protocol. A USB connector has been included for future connectivity.

The pump controller is able to accept voltages from 100-127 and 200-240V (+/- 10%) without the need for intervention.



Service

nXDS has been designed specifically with end user serviceability in mind.

Technological improvements in tip-seal design have significantly extended the in-service lifetime of the nXDS product, which could be as long as five years. The pump will advise the user to check the performance of the pump via a flashing LED on the control panel and via the status word in serial comms. If it is required, tip-seal exchange can be accomplished in under 10 minutes with only a simple Allen Key (hex wrench).

Beyond this, a bearing service can now be performed by an end user in approximately 2 hours. Alternatively, the nXDS can now be returned to a wider choice of service hubs for Edwards own personnel to perform the task.

Ordering information

Standard product		Corrosion resistant (C) variants		(R) Variants without gas ballast	
nXDS6i	A735 01 983	nXDS6iC	A735 02 983	nXDS6iR	A735 03 983
nXDS10i	A736 01 983	nXDS10iC	A736 02 983	nXDS10iR	A736 03 983
nXDS15i	A737 01 983	nXDS15iC	A737 02 983	nXDS15iR	A737 03 983
nXDS20i	A738 01 983	nXDS20iC	A738 02 983	nXDS20iR	A738 03 983

Controllers and accessories

The TIC Turbo and Instrument Controller automatically recognises the nXDS pump when connected to the backing pump connector as the controller adopts serial communications mode when connected to the nXDS. There is no need to use a relay box to interface to nXDS.

Speed control and pump run hours etc can be readily accessed from the display. The TIC can also control an nEXT turbopump plus as an option, up to three gauges at the same time as a nXDS pump.

Customers already owning a TIC can upgrade their software to enable interfacing to nXDS.

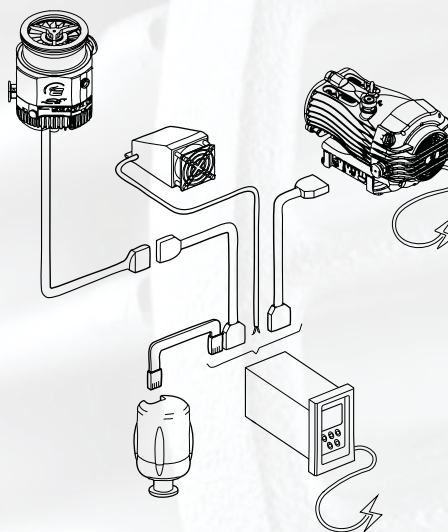

Spares and accessories

TIC (Turbo) 200W	D397 22 000	Electrical Supply Cable 2m, UK	A505 05 000
TIC (Turbo and Instruments) 200W	D397 12 000	Electrical Supply Cable 2m, North Europe	A505 06 000
Gas Ballast Adaptor Kit	A735 01 809	Electrical Supply Cable 2m, North America/Japan	A505 07 000
Silencer (NW25)	A505 97 000	Electrical Supply Cable 2m, No plug	A505 08 000
Inlet/Outlet Filter 5um (NW25/NW25)	A505 97 805	Interface cable 1.0m	D397 00 835
Tip Seal Service Kit	A735 01 801	Interface cable 2.0m	D397 00 836
Bearing Service Kit	A735 01 802	Interface cable 5.0m	D397 00 837

Global contacts

Belgium

Brussels +32 2 300 0730

Brazil

Sao Paulo +55 11 3952 5000

China

Shanghai (toll free) 400 111 9618

France

Paris +33 1 4121 1256

Germany

Munich 0800 000 1456

India

Pune +91 20 4075 2222

Israel

Qiryat Gat +972 8 681 0633

Italy

Milan +39 02 48 4471

Japan

Yachiyo +81 47 458 8831

Korea

Bundang +82 31 716 7070

Singapore

Singapore +65 6546 8408

Taiwan R.O.C.

Jhunan Town +886 3758 1000

United Kingdom

Crawley +44 1293 528844

UK (local rate) 08459 212223

United States

Niagara (toll free) 1 800 848 9800